

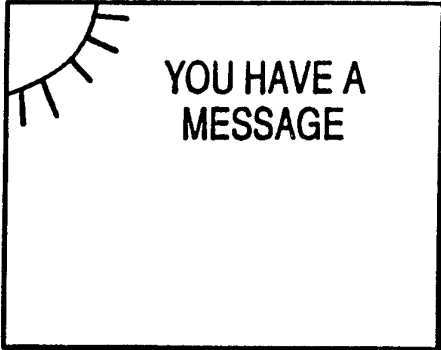

## INTERNATIONAL APPLICATION PUBLISHED UNDER THE PATENT COOPERATION TREATY (PCT)

<b>(51) International Patent Classification <sup>5</sup> :</b>  <b>H04N 7/16</b>	<b>A1</b>	<b>(11) International Publication Number:</b> <b>WO 93/11639</b>  <b>(43) International Publication Date:</b> 10 June 1993 (10.06.93)
<b>(21) International Application Number:</b> PCT/US92/10109 <b>(22) International Filing Date:</b> 30 November 1992 (30.11.92)  <b>(30) Priority data:</b> 799,987                      29 November 1991 (29.11.91) US  <b>(71) Applicant:</b> SCIENTIFIC-ATLANTA, INC. [US/US]; One Technology Parkway South, P.O. Box 105600, Norcross, GA 30092-2967 (US).  <b>(72) Inventors:</b> BANKER, Robert, O. ; 1581 Chambee Gap Road, Cumming, GA 30130 (US). BACON, Kinney, C. ; 2820 Springtime Court, Lawrence, GA 30243 (US). BAGLEY, Julius, B. ; 296 Sandhurst Way, Marietta, GA 30060 (US).		<b>(74) Agents:</b> SHEA, Michael, J. et al. ; Banner, Birch, McKie & Beckett, 1001 G Street, N.W., 11th Floor, Washington, DC 20001 (US).  <b>(81) Designated States:</b> AU, JP.  <b>Published</b> <i>With international search report.</i>
<b>(54) Title:</b> METHOD AND APPARATUS FOR PROVIDING MESSAGE INFORMATION TO SUBSCRIBERS IN A CABLE TELEVISION SYSTEM		
		
<b>(57) Abstract</b>  A subscriber terminal apparatus for a television in an in-band subscription television system is provided. The subscriber terminal includes a receiver for receiving a television signal including video, audio, and data information. A selector selects a channel of the television signal. A memory stores a plurality of barker screens providing messages regarding one or more channels of the television signal. An on-screen display control circuit controls the display of the barker screens on the television. A processor retrieving a barker screen from the memory and supplies the retrieved screen to the on-screen display control circuit if the barker screen provides a message regarding a selected channel. Barker screen information may also be obtained from a dedicated data channel or a six megahertz video barker channel.		

*FOR THE PURPOSES OF INFORMATION ONLY*

Codes used to identify States party to the PCT on the front pages of pamphlets publishing international applications under the PCT.

AT	Austria	FR	France	MR	Mauritania
AU	Australia	GA	Gabon	MW	Malawi
BB	Barbados	GB	United Kingdom	NL	Netherlands
BE	Belgium	GN	Guinea	NO	Norway
BF	Burkina Faso	GR	Greece	NZ	New Zealand
BG	Bulgaria	HU	Hungary	PL	Poland
BJ	Benin	IE	Ireland	PT	Portugal
BR	Brazil	IT	Italy	RO	Romania
CA	Canada	JP	Japan	RU	Russian Federation
CF	Central African Republic	KP	Democratic People's Republic of Korea	SD	Sudan
CG	Congo	KR	Republic of Korea	SE	Sweden
CH	Switzerland	KZ	Kazakhstan	SK	Slovak Republic
CI	Côte d'Ivoire	LJ	Liechtenstein	SN	Senegal
CM	Cameroon	LK	Sri Lanka	SU	Soviet Union
CS	Czechoslovakia	LU	Luxembourg	TD	Chad
CZ	Czech Republic	MC	Monaco	TG	Togo
DE	Germany	MG	Madagascar	UA	Ukraine
DK	Denmark	ML	Mali	US	United States of America
ES	Spain	MN	Mongolia	VN	Viet Nam
FI	Finland				

- 1 -

**METHOD AND APPARATUS FOR PROVIDING MESSAGE  
INFORMATION TO SUBSCRIBERS IN A CABLE TELEVISION SYSTEM**

**TECHNICAL FIELD**

The present invention generally relates to a method and apparatus for providing information to subscribers in a cable television system and, more particularly, to a method and apparatus for generating and forwarding messages including characters for display on a television receiver in a cable television system. The messages may, for example, include barker information.

**BACKGROUND OF THE INVENTION**

One important feature of a cable television system is the capability of a system operator to effectively provide information to subscribers. Video barker channels are one example of such information. For example, when a subscriber selects a channel which he or she is not able to view, a six megahertz video barker channel may be tuned which provides a message such as shown in Figure 1 on the subscriber's television to indicate that the selected channel is not available for viewing. A subscriber may not be able to view a selected channel for a number of reasons. For example, the selected channel may have a pay-per-view event which the subscriber has not purchased. Alternatively, the channel may be a premium channel for which the subscriber is not authorized. The channel may also be under parental control or may simply not be available in the cable system. Each of these reasons may prevent a subscriber from viewing a selected channel.

In prior art systems, the same video barker channel is typically tuned for each of the above situations. Accordingly, a generic message such as that shown in Figure 1 is provided. Thus, although a subscriber is provided an indication that he or she cannot view a selected channel, no specific reason is provided. Of course, an operator could provide

separate barker channels for each of these situations and others. However, the use of separate six megahertz video barker channels to provide such information reduces the number of channels available for other programming.

#### **SUMMARY OF THE INVENTION**

Accordingly, it is an object of the present invention to provide a method and apparatus for providing message information to subscribers.

It is a further object of the present invention to provide message information to a subscriber utilizing a minimum bandwidth.

In accordance with the present invention, a subscriber terminal apparatus for a television in an in-band subscription television system includes a receiver for receiving a television signal including video, audio, and data information. A selector selects a channel of the television signal. A memory stores a plurality of barker screens providing messages regarding one or more channels of the television signal. An on-screen display control circuit controls the display of the barker screens on the television. A processor retrieving a barker screen from the memory and supplies the retrieved screen to the on-screen display control circuit if the barker screen provides a message regarding a selected channel.

This arrangement permits specific information to be provided to a subscriber tuning a channel which he or she is not able to view for a particular reason. This capability is provided without the need for using a six megahertz video barker channel and thus the channel capacity of a system operator is enhanced.

#### **BRIEF DESCRIPTION OF THE DRAWINGS**

A more complete appreciation of the invention and many of the attendant advantages thereof will be readily obtained as the invention becomes better understood by reference to the following detailed description when considered in connection with the accompanying drawings.

Figure 1 depicts a prior art barker provided to inform a subscriber that a channel is unavailable.

Figure 2 is a block diagram of a headend for an in-band cable television system in accordance with the present invention.

Figure 3 is a block diagram of scrambler 204f shown in Figure 2.

Figure 4 is a block diagram of a baseband subscriber terminal in accordance with the present invention.

Figure 5A is a block diagram of the on-screen display control of Figure 4.

Figure 5B illustrates memory locations of RAM of the on-screen display of Figure 5A.

Figure 5C illustrates the configuration of the on-screen display.

Figure 6A illustrates a message transaction in accordance with the present invention.

Figure 6B illustrates a message definition transaction in accordance with the present invention.

Figure 7 illustrates an on-screen message alert in accordance with the present invention.

Figure 8 illustrates a barker transaction in accordance with the present invention.

#### DETAILED DESCRIPTION OF THE PREFERRED EMBODIMENT

Figure 2 is a block diagram of a subscription television system in which the present invention may be implemented. Billing computer 201 includes a subscriber database and generates a monthly bill for the subscribers in the system based on level of service and any pay-per-view and impulse pay-per-view purchases. System control computer 202 such as an HP-1000 is interfaced to billing computer 201. System control computer 202 receives transactions such as authorization transactions from billing computer 201 and formats and forwards transactions to headend controller 203 and addressable transmitter (ATX) 208. System control computer 202 also generates system set-up parameters such as scrambled channels. System control computer 202 configures tuning frequencies of the channels provided to the subscribers and controls on-screen display as described in greater detail below. A system control computer interface is responsible for

gathering and appropriately routing the data leaving the system control computer 202. Out-of-band data is sent to addressable transmitter 208 and in-band data is sent to headend controller 203.

Addressable transmitter 208 transmits data to out-of-band subscriber terminals via a dedicated FM data channel such as a 108.2 megahertz data channel in the cable television distribution system. This channel, known as the data carrier, is used to transmit both addressable commands intended for a particular out-of-band subscriber terminal and global commands intended for all out-of-band subscriber terminals in the system. Out-of-band subscriber terminals contain a receiver that is listening to the commands sent over this data channel. Unlike the in-band transactions described in detail below below, out-of-band subscriber terminals receive data over this channel no matter what channel the subscriber terminal is tuned to.

Headend controller 203 is coupled to system control computer 202 and formats system control computer transactions for scramblers 204a-204f. Headend controller 203 stores all transactions and has the ability to perform continuous refreshes. The requirement to constantly, repetitively and efficiently transmit the information base arises since there is no permanently tuned data channel for in-band data transactions. Thus, all information flow to the in-band subscriber terminals is subject to the indeterminate availability of a data path to the in-band subscriber terminals. However, to further complicate matters, some of the information is real time critical, i.e. it may pertain to events that currently in progress or it may be critical to maintenance or service changes. In other information, although less time critical in nature, may be of considerable value. Some information is pertinent only to certain of the data streams while certain information causes a write to nonvolatile memory in the in-band subscriber terminals and must be sent at minimal intervals.

Different groups of data are transmitted on a serial data channel from headend controller 203 to the scramblers. These data groups or data streams are: (1) OFF channel data, (2) barker channel data, (3) pay-per-view (PPV) channel data, (4) premium channel data, (5) scroll channel data, and (6) message channel data. Reference should be made

to U.S. Patent No. 5,058,160, incorporated herein, for details of data streams (1)-(4). Data streams (5) and (6) relate to the communication of message information from a system operator to subscribers and are discussed in greater detail in a commonly assigned application entitled "Method and Apparatus for Providing Message Information to Subscribers in a Cable Television System" (Attorney Docket No. 1263.038213) filed on an even date herewith and incorporated herein by reference. Each data stream has a unique group address that is received only by scramblers having a matching address. For instance, premium channel data may have a group address of 01, and therefore all scramblers on premium channels should have a group address of 01. Headend controller 103 determines which data is output in each data stream. In an alternative embodiment, scroll channel data and message channel data may be provided to scramblers 204e and 204f on a separate channel in order to maintain a high data rate for the information in data streams (1)-(4).

Scramblers 204a-204f are coupled to headend controller 203 and may be used to selectively scramble television signals for improved security in a subscription television system that is equipped with appropriate descramblers. The video, for example, may be scrambled in any manner known in the art including sync suppression and video inversion. For illustrative purposes only, it is assumed that scramblers 204a-204f respectively correspond only to data streams (1) - (6) identified above. The outputs of scramblers 204a-204f are respectively supplied to modulators 205a-205f. The outputs of modulators 205a-205f are supplied to combiner 206 which outputs a television signal for distribution over distribution system 208 to both in-band subscriber terminals 209 and out-of-band subscriber terminals 210. Data from scramblers, e.g., 204a, can also be provided to data inserter 207 for the transmission of in-band data on non-scrambled channels.

Figure 3 is a block diagram of scrambler 204f shown in Figure 2. Scrambler 204f receives message channel data from headend controller 203. The message channel data includes character information for display screens which may be addressed to one or more subscriber terminals for display on an associated television. Scrambler 204f

includes data circuitry 301, digital circuitry 302, analog circuitry 303, and video inversion circuitry 304. Data circuitry 301 includes line interfaces 305 and 306, synchronous data link control (SDLC) 307, microprocessor 308, and digital circuit interface 309. SDLC 307 controls communication via line interface 306 between scrambler 204f and headend controller 203. Microprocessor 308 receives and processes information from SDLC 307. Information such as message information is stored in non-volatile message memory of microprocessor 308. To ensure sufficient memory for message data, there is preferably at least 128 K of non-volatile message memory. Read/write memory of microprocessor 308 stores temporary information. Interface circuit 309 interfaces the data circuitry 301 to the digital circuitry 302.

Digital circuitry 302 includes interface circuit 310, phase locked loop 311, microprocessor 312, inversion control circuit 313, video attenuation logic 314, timing and tag information generator 315, digitized pulse generator 316, and parameter selection circuit 317. Interface circuit 310 interfaces digital circuitry 302 with data circuitry 301. Microprocessor 312 controls all essential functions and features of scrambler 204f. Microprocessor 312 extracts and processes message data from the data circuitry 301 and controls the scrambling modes of the system. Digitized pulse generator 316 generates the specific pulses placed on the sound carrier via the analog circuitry under the control of microprocessor 312. These pulses represent authorization and control information, descrambling information including timing pulses, and message information. Microprocessor 312 is also coupled to parameter selection circuitry 317 which may be a front panel display and keyboard which permits an operator to select various modes of operation, e.g., scrambling.

Analog circuitry 303 includes AM modulator 318, video attenuation circuitry 319, low pass filter 320, buffer amplifier 321, scene illumination detector 322, and synchronization separator 323. AM modulator 318 modulates the pulses from pulse generator 316 onto an audio IF signal from modulator 205f and outputs the modulated signal to modulator 205f. Video attenuation circuitry 319 selectively provides sync suppression type scrambling and attenuates a video IF



signal from modulator 205f under the control of video attenuation logic 314.

Baseband video input is filtered with low pass filter 320 which may be a sharp cut-off phase equalized low pass filter. Low pass filter 320 removes high frequency noise that could interfere with the baseband video. After filtering, the video is amplified back to its original level by video amplifier 321. Sync separator 323 extracts synchronization information which is then sent to microprocessor 312 to provide timing information such as composite and vertical sync and odd/even field indication. Scene illumination detector 322 determines the average luminance level of a scene, which level is supplied to an A/D converter of microprocessor 312. Microprocessor 312 uses this luminance information to detect scene changes in order to determine when scrambling modes may optimally be changed. The composite synchronization signal is supplied to the input of phase locked loop (PLL) 311. Phase locked loop 311 locks the system clock to the line rate.

The baseband video signal from amplifier 321 is also supplied to video inversion circuitry 304. Video inversion circuitry 304 includes automatic gain control (AGC) and DC clamping circuitry 324, split sync generator 325, and video inversion circuit 326. The AGC of circuit 324 adjusts the incoming signal to a predetermined value such as 1 V peak to peak. The DC clamping of circuitry 324 forces the bottom of the sync tip to be at ground. The output of circuitry 324 is supplied to a split synchronization circuit 325. The details of split synchronization circuitry is discussed in detail in commonly assigned U.S. Patent No. 4,924,498, incorporated herein by reference. The output of split synchronization circuitry 325 is provided to inverting circuitry 326 for inverting the baseband video about an inversion axis. Inversion is controlled in accordance with signals from inversion control circuit 313.

Scrambler 204e receives scroll channel data from headend controller 203. The scroll channel data includes character information which defines barker screens which have been designed by the system operator on system control computer 202. Scrambler 204e is

configured in the same manner as scrambler 204f but need not include a 128 K memory. Rather, a 32 K of non-volatile memory may be utilized. Scramblers 204e and 204f respectively store the scroll channel data and message channel data and continuously output the data on the corresponding scroll and message channels. Since the scroll channel data and the message channel data preferably define a plurality of barker and message screens, the stored data is output in a loop. Thus, if there are 8 barker screens, the information for the first screen is followed by the information for the second screen and so on. When the information for the eighth screen is sent, it is followed by the information for the first screen. A similar loop is established for the message channel data. Details of scramblers 204a-204d may be found in the above-identified U.S. Patent No. 5,058,160.

Figure 4 is a block diagram illustrating the components of a subscriber terminal 209 in accordance with the present invention. Although the subscriber terminal is described below as a baseband subscriber terminal, it will be apparent that other subscriber terminals such as RF subscriber terminals may be utilized. The signal from distribution system 208 is supplied to up/down converter 401. Up/down converter 401 uses a phase locked loop under the control of data and control circuit 402 to convert a selected RF input signal to a 4.5 megahertz signal. Filter 403 such as a SAW filter filters the signal. Demodulating and descrambling circuitry 404 demodulates and descrambles the filtered signal under the control of data and control circuit 402. Demodulating and descrambling circuitry 404 also performs pulse detection to recover the data modulated onto the audio carrier. The data is supplied to data and control circuit 402. Volume control of the audio is performed by demodulating and descrambling circuitry 404 under the control of data and control circuit 402 and microprocessor 410 as described in U.S. Patent No. 5,054,071, incorporated herein by reference.

The output of demodulating and descrambling circuitry 404 is an unscrambled baseband video signal which is supplied to on-screen display control circuit 406. On-screen display control circuit 406 is preferably a Mitsubishi M50556 on-screen display controller. On-screen

display control circuit 406 selectively generates on-screen character displays in place of or overlaid on the video signal. Modulator 407 converts the signal containing the video, audio, and/or characters from display control 406 on channel 3/4 which is supplied to television 408.

Microprocessor 410 controls the overall operation of subscriber terminal 400. Keyboard 411 on a front panel of subscriber terminal 209 generates subscriber supplied signals for channel tuning, volume level, and the like which are supplied to microprocessor 410. Remote receiver 415 receives commands from IR remote 412, as is well known in the art, and provides the commands to microprocessor 410. Reset circuitry 416 resets microprocessor 410 and/or data and control circuit 402 to ensure proper operation of the system if there have been power failures, power surges, and the like. When keyboard 411 or IR remote 412 is utilized to select a channel, microprocessor 410 instructs data and control circuit 402 to appropriately control up/down converter 401 to tune the selected channel. Data and control circuit 402 utilizes recovered descrambling data to generate appropriate control signals, e.g. inversion control and sync restore signals for descrambling the input television signal. Microprocessor 410 determines whether data and control circuit 402 carries out descrambling on the basis of authorizations downloaded from system control computer. LED display 413 displays channel numbers and diagnostics. NVM 414 stores data, e.g., authorizations, terminal configurations. Subscriber terminal 400 may optionally include IPPV module 417. Module 417 allows the subscriber to authorize his or her subscriber terminal to receive a pay-per-view event, store the data associated with the purchase of that event in non-volatile memory, and transmit the data to the system operator via a telephone return path or an RF return path. The subscriber is then billed for the purchased events.

Figure 5A is a block diagram of the Mitsubishi M50456 on-screen display control circuit. The on-screen display control includes character ROM 501 for storing a character set. In a preferred embodiment, the following sixty four characters are stored in character ROM 501:

blank

capital letters A-Z  
 cursor -- icon  
 numbers 0-9  
 blank volume level  
 four volume level bars  
 (Pound Sterling)  
 [ ] ? - : \$ ' , . \* # & +  
 single character Am Pm Ch

Display RAM 502 is set with data from microprocessor 410 via serial input  $S_{IN}$  to generate on screen displays using these sixty four characters. This data may be provided from a number of sources. A first source is message data from message channel data scrambler 204f. A second source is scroll channel data from scroll channel data scrambler 204e. A third source is barker data from ROM of subscriber terminal microprocessor 410. Another source of display information is menu screen information stored in microprocessor ROM 420. The use of such memory screens is described in greater detail in a commonly assigned application entitled "Method and Apparatus for Providing an On-Screen User Interface for a Subscription Television Terminal" (Attorney Docket No. 1263.038211), incorporated herein by reference. Reference may also be made to Scientific Atlanta Publication No. 69P2837 entitled: "Model 8600 Set Top Terminal User's Guide" available from Scientific Atlanta and incorporated herein. Display RAM 502 includes 240 memory locations for characters to be displayed on television 408. As shown in Figure 5B, each memory location includes a blinking bit which determines whether the character is blinking, character color bits which determine the color of the character, and a character code identifying one of the characters stored in ROM 501. The configuration of the on-screen display is shown in Figure 5C and can be seen to consist of ten rows of twenty four characters each. The information in display RAM 502 determines what appears at each of the screen positions 1-240.

There are three modes of on-screen display control circuit. The first mode simply provides the video of a selected channel. The second mode is a video overlay mode in which character information is

overlaid on the video of a selected channel. The second mode may be used for example to display time, channel number, and channel identification information when a subscriber tunes to different channels. Channel identification information is described in a commonly assigned copending application entitled "Method and Apparatus for Displaying Channel Identification Information" (Attorney Docket No. 1263.038212), filed on an even date herewith and incorporated herein by reference. The third mode is a character mode in which character information is presented on a plain background. This mode is preferably used for messages, for example.

It will be apparent that a system operator may utilize either mode to display information to subscribers and the present invention is not limited to with respect to whether information is presented on a solid background or overlaid onto a video signal.

Addressable message transaction transmissions for on-screen display may be forwarded to subscriber terminals in the cable system using message scrambler 204f. Figure 6A illustrates a message transaction transmission for forwarding characters to subscriber terminals. Each message transaction transmission has a display number field associated therewith for identifying a message. In accordance with a present embodiment, the display numbers may range from 0 to 65535, although the invention is not limited in this respect. Additionally, a subset of the display numbers, for example from 0 to 7, are reserved for barker text downloaded by scroll channel scrambler 204e as discussed in greater detail below. Each message may include up to sixteen screens, each screen having 240 characters. The characters for each screen are sent in up to eleven sequenced transactions such as illustrated in Figure 6A. A sequence number field identifies the transaction transmissions in the sequence of transaction transmissions. The transaction transmissions also include a screen number field for identifying the screens in a sequence of screens and a last screen flag for identifying the last screen in a sequence of screens. If the message is less than 240 characters and message scrambler 204f is configured to transmit variable length messages, fewer transaction transmissions need to be sent to complete the message. The message transaction

transmission shown in Figure 6A may then also include a last transaction flag. As discussed in U.S. Patent No. 5,058,160, the rate at which transactions are sent is 29 transactions per second. At this transaction rate, slightly more than three seconds is required to send eight 240 character messages over the same message channel. Accordingly, the average wait to start receiving one of these messages is approximately 1.5 seconds.

The message channel utilizes a scrambler configured as scrambler 204f with internal data RAM which stores the message loop from headend controller 103 and retransmits it constantly to the subscriber terminals under the control of microprocessor 312. The serial nature of the system is such that as the number of messages in the message loop increases, the response time for a subscriber to receive a message increases. Additional message channels may be utilized to speed up the response time.

The message transaction also permits a system operator to instruct on-screen display control circuit 406 to blank the display on television 408 until the entire screen is received and ready for display. Alternatively, on-screen display control circuit 406 may display the characters as they are received until the message is completed.

A message definition transaction transmission is depicted in Figure 6B. An ID field identifies the transaction transmission as a message definition. This transaction transmission indicates that a message has been sent to the subscriber terminal. The messages may be individually addressed or addressed to members of a group of subscriber terminals defined by the address data. Using a downloaded transaction, a subscriber terminal can be assigned to one or more groups. In a preferred embodiment, 64 groups are defined, but the invention is not limited in this respect. The message definition transaction defines a background color field for setting the background color of the on-screen display and a tuning field which instructs the terminal which channel to tune to receive the message which, in this example, is the message channel. When a subscriber terminal receives a message definition transaction transmission which is addressed to it or to any group of which it is a member, a message alert in accordance

with the alert data field may be provided. The subscriber may view the message by use of a menu structure described in a commonly assigned application entitled "Method and Apparatus for Providing an On-Screen User Interface for a Subscription Television Terminal" (Attorney Docket No. 1263.038211), incorporated herein by reference. In order to obtain the message, data and control circuit 402 of the subscriber terminal tunes up/down converter 401 to the channel defined by the tuning field and searches for a message transaction transmission with the same display number as in the message definition transaction transmission. In a preferred embodiment, the tuning data instructs the subscriber terminal to tune either the channel currently tuned, one of the message channels, the scroll channel, or the OFF channel to retrieve the appropriate message. The message definition transaction transmission of Figure 6B is preferably sent on all datastreams output by headend controller 103 in order to most quickly inform a subscriber that he or she has a message.

Although multiple messages may be sent to a subscriber terminal, each subscriber terminal only maintains one pending message definition transaction. This is the message obtained by using the menu structure referenced above. As long as messages are not read, the pending message definition is updated as new message definition transactions are received. The priority of this update is in accordance with the display number in the message definition transaction, such that for two unread messages, the lower display number is read first. A message that has not been read always has priority over a message which has been read.

When a subscriber terminal receives a message definition transaction defining a message for that subscriber terminal, a message alert may be provided. For example, microprocessor 410 may control a segment of LED display 413 to blink on and off. The LED alert ends when the last screen of the message is received and if there are no more active unread messages for the subscriber terminal. The message definition may include data which instructs microprocessor 410 to generate an on-screen message alert. If such data is included in the message definition transaction, an on-screen message alert such as that

in Figure 7 will overlay the video until a key on keyboard 411 of the subscriber terminal or remote control 412 is pressed. Preferably, the character codes and layout of the on-screen message alert are stored in ROM of microprocessor 410. The message definition transaction instructs microprocessor 410 to supply the appropriate character codes and layout information to on-screen display control 406. No alert may be given and no messages received if the subscriber terminal is not tuned to a channel with data.

When the message is displayed, it remains on the screen until the user changes the screen. If there are multiple screens, the subscriber may cycle through all message screens and back to the beginning as many times as desired. At each new screen, there will be a waiting time until the appropriate screen is retrieved. When the last screen of a message has been received, the message is defined as being read. After all active messages have been read, the messages can be reread.

Messages are transmitted for a period of time configured by the headend so that message channel data is minimized. An active message control transaction from the headend flags all groups with active messages is sent periodically. This controls message expiration.

As noted above, a subset of the message transactions may be used for barkers, i.e., message transaction transmissions having display numbers of 0-7 associated therewith. It will be apparent that more or less barkers may be used. It is desirable that a system operator provide specific information to a subscriber concerning, for example, his inability to view a particular channel. Such specific information promotes a user friendly interface with the subscriber. A number of conditions exist for which such barkers are useful. Barkers may be tuned if a subscriber terminal is

1. is OFF
2. is tuned to a non-existent channel
3. is not authorized for a channel
3. has timed-out, i.e, has been disconnected from the cable for longer than a predetermined period of time
4. has been tampered with



5. tunes a parentally controlled channel
6. tunes a pay-per-view channel without a preview
8. tunes an IPPV channel with no free time
9. has a full IPPV event memory
10. is turned ON

In accordance with the present invention, one method of providing barkers to subscribers is through the use of downloaded text barkers using the scroll channel output of scrambler 204e. The scroll channel is a dedicated data channel which only sends transactions that define downloaded text barkers. These downloaded text barkers are defined by the system control computer and downloaded to the subscriber terminal. Each text barker may include up to 16 pages, each page including 240 characters. Although barkers are a subset of messages utilizing a predetermined range of display numbers, they are preferably transmitted on the separate scroll channel so that other data streams, including message data, are not affected.

A barker transaction transmission is illustrated in Figure 6. The transaction transmission includes an identification identifying it as a barker transaction transmission and information regarding each of the barker conditions specified above. For each condition, the transaction transmission includes a background color field for setting the background color on which the barker information is presented. The information may be presented on one of a number of different solid colors such as low intensity blue, high intensity blue, black, green, blue, red, and magenta. Alternatively, the information may be overlaid onto the video information. The transaction transmission includes a field identifying where the appropriate barker information may be found. The information may be found on a six megahertz video channel, the scroll channel, or in the read only memory 420 of microprocessor 410, as set forth in greater detail below. The transaction transmission also includes the display number for the barker screen or screens as discussed above.

The transaction also identifies the channel which is tuned after the scroll channel data is obtained. The final channel tuned may be the selected channel, the video barker, the scroll channel, or the OFF

channel. As noted above, microprocessor 410 preferably instructs on-screen display control circuit 406 to present barkers on a solid background, the color of the background being determined in accordance with the instructions contained in the barker transaction. Accordingly, it does not matter what channel is tuned by the up/down converter. Accordingly, the up down converter may be set to any channel after the barker screen information is retrieved. This is a useful feature since it allows a system operator to instruct the subscriber terminal to tune to a data channel while the subscriber is viewing a barker. The subscriber terminal then has an opportunity to receive any data addressed to it. This is particularly beneficial if, for example, a pay-per-view type barker is being viewed. Thus, it may be that the subscriber is awaiting authorization for some event. Thus, the barker transaction may instruct microprocessor 410 to control ASIC 202 to set up/downconverter 201 to the data channel having fast-poll pay-per-view authorization data. This allows a subscriber to quickly obtain authorization information. By instructing the subscriber terminal to tune a particular data channel upon the viewing of a particular barker, the system operator can connect the subscriber terminal to a data channel most likely to quickly provide data such as authorizations. Thus, the barker transaction includes two tuning instructions. The first instructs the subscriber terminal to tune to where the barker information may be found. The second instructs the subscriber terminal to tune to where other information may be found.

Thus, in accordance with the present invention, downloaded text barkers are forwarded from the headend. Since the barker information characters are sent via a data transaction, a video barker channel is not necessary and the cable operator can utilize the valuable channel capacity. Although long response times could arise if the transactions containing the barker channel characters were interleaved with other transactions in the system, this may be overcome by the utilization of a separate scroll channel for the barkers. This channel includes only the barker transactions and no others.

Also in accordance with the present invention, barker information may be provided using a six megahertz video channel.

Finally, barker information may be generated from screens stored in ROM. As noted above, a number of conditions exist for which a barker screen is desirable. A number of these conditions are routine. Accordingly, in accordance with the present invention, information for generating a number of barker screens is stored in read only memory of microprocessor 410. When a subscriber selects a channel requiring one of these ROM barkers, the barker transaction instructs microprocessor 410 that the screen characters are in ROM and provides the appropriate display number. Microprocessor 410 uses the display number to retrieve the appropriate character codes and other display information which is then provided to on-screen display control 406. As noted above, if downloaded text barkers are utilized, the barker transaction instructs microprocessor 410 that the screen characters are on a data channel and provides the appropriate display number. Microprocessor 410 tunes the subscriber terminal accordingly and uses the display number to retrieve the barker data. However, with ROM barkers, there is no delay while waiting for data. Further, as with the downloaded text barkers, there is no need of a six megahertz video barker channel and thus channel capacity for other programming is increased. Various ROM barkers may be implemented.

An OFF barker such as illustrated in Figure 9A may be presented when the subscriber terminal is OFF. Since the subscriber terminal is OFF, the OFF barker is simply a blank screen. As discussed in greater detail in the above-identified U.S. Patent No. 5,058,160, when a subscriber terminal is switched OFF, an OFF channel is tuned for the purpose of receiving in-band data.

An INVALID CHANNEL barker such as illustrated in Figure 9B may be presented when a subscriber selects a channel which does not appear in the cable system. Thus, a subscriber is informed that a particular channel is not available.

A NOT AUTHORIZED barker such as illustrated in Figure 9C may be presented when a subscriber selects a channel having a premium service which the subscriber has not ordered. Thus, a subscriber is informed that he or she has not ordered a particular channel. It is noted that this barker uses the channel identification

information HBO which is described in greater detail the the above-referenced commonly assigned application.

A TIME-OUT barker such as illustrated in Figure 9D may be presented if the subscriber terminal does not periodically receive a refresh signal transmitted from the headend. The refresh period is globally controlled by the headend. Thus, a subscriber is informed that he or she should check the connection of the input cable to the terminal in order to ensure proper operation.

A TURN-ON barker such as illustrated in Figure 9E may be presented every time a subscriber terminal is switched ON. The barker is cleared when the subscriber changes the channel.

A PARENTAL CONTROL barker such as shown in Figure 9F may be presented when a subscriber selects a channel which is under parental control. This barker is cleared when parental control of the channel is released such as by entry of an appropriate parental code number. Thus, a subscriber is informed that a particular channel is under parental control. It is noted that this barker uses the channel identification information HAPY which is described in greater detail the the above-referenced commonly assigned application.

A TAMPER barker such as illustrated in Figure 9G may be presented when the microprocessor of the subscriber terminal detects tampering. As can be seen, this barker is blank.

The PPV barker such as illustrated in Figure 9H may be presented when a subscriber selects a channel showing a pay-per-view event and no preview time is remains or has been provided. If the user calls and buys the event, the headend will authorize the subscriber terminal and the event may be viewed. This barker may also be presented when an IPPV channel is selected and and an event is not purchasable, i.e., it is outside the purchase window. Thus, a subscriber is informed that a particular channel may not be viewed since it contains pay-per-view or impulse pay-per-view events. It is noted that this barker uses the channel identification information PPV1 which is described in greater detail the the above-referenced commonly assigned application.

The IPPV - NO PURCHASE barker such as illustrated in Figure 9I may be presented when a subscriber attempts to purchase an IPPV event and he or she is not permitted to make any additional purchases. This situation may arise, for example, when a subscriber has not paid for recent IPPV purchases or recent IPPV purchases have not been reported back to the billing computer. Thus, a subscriber is informed that he or she is unable to purchase any additional IPPV events.

The IPPV HELP barker such as illustrated in Figure 9J may be presented when the subscriber selects a channel showing an IPPV event and the purchase window is still active. Thus, a subscriber is informed that he or she can purchase the event being shown on the selected channel. It is noted that this barker uses the channel identification information HTCH which is described in greater detail in the above-referenced commonly assigned application.

It will be apparent that the above-identified ROM barkers are merely representative of a currently preferred embodiment and the present invention is not limited in this respect.

It is to be understood that the invention is not limited to the illustrations described and shown herein which are deemed to be merely illustrative. The invention rather is intended to encompass all such modifications which are within its spirit and scope as defined by the appended claims.

**WE CLAIM**

1. A subscriber terminal apparatus for a television in an in-band subscription television system, comprising:

a receiver for receiving a television signal including video, audio, and data information;

selecting means for selecting a channel of said television signal;

a memory for storing a plurality of barker screens providing messages regarding one or more channels of said television signal;

an on-screen display control circuit for controlling the display of said barker screens on said television; and

processing means for retrieving a barker screen from said memory and supplying the retrieved screen to said on-screen display control circuit if the barker screen provides a message regarding a selected channel.

2. A method of displaying information on a television, the method comprising the steps of:

receiving a television signal including video, audio, and data information;

selecting a channel of said television signal;

storing a plurality of barker screens providing messages regarding one or more channels of said television signal; and

retrieving a stored barker screen and supplying the retrieved screen to said television if the barker screen provides a message regarding a selected channel.

3. A subscriber terminal apparatus for a television in an in-band subscription television system, comprising:

a receiver for receiving a television signal including video, audio, and data information;

selecting means for selecting a channel of said television signal;

an on-screen display control circuit for controlling the display of character information on said television;

a tuner for tuning a channel of said television signal having in-band character data providing messages regarding one or more channels of said television signal; and

processing means for tuning said tuner to retrieve character data and for supplying the retrieved character data to said on-screen display control circuit if the in-band character data relates to a selected channel.

4. A method of displaying information on a television, the method comprising the steps of:

receiving a television signal including video, audio, and data information;

selecting a channel of said television signal;

tuning to a channel of said television signal having in-band character data if the in-band character data relates to a selected channel; and

supplying the character data to said television.

THIS CHANNEL  
IS NOT AVAILABLE

FIG. 1

YOU HAVE A  
MESSAGE



FIG. 7

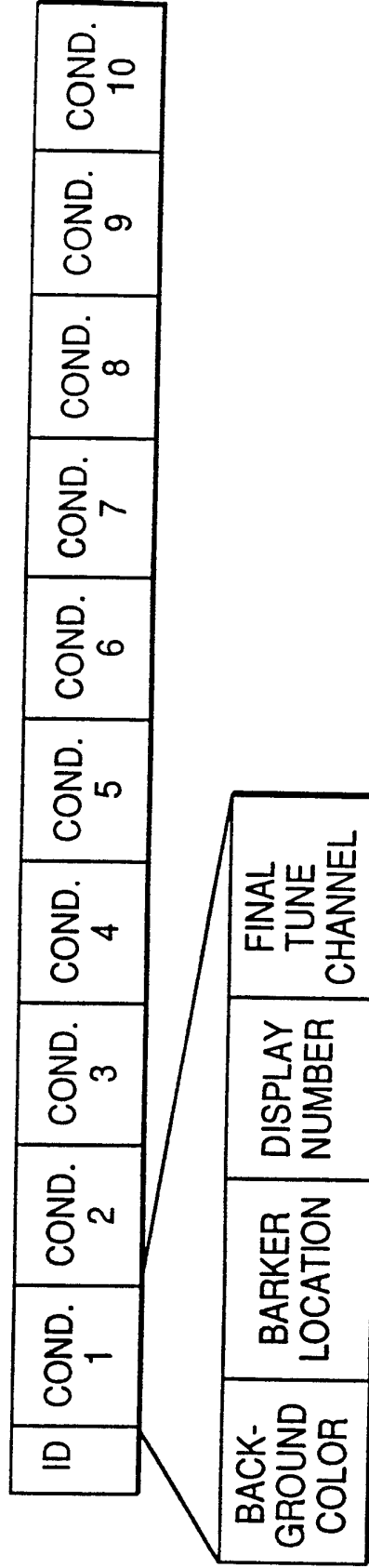

FIG. 8



FIG. 2

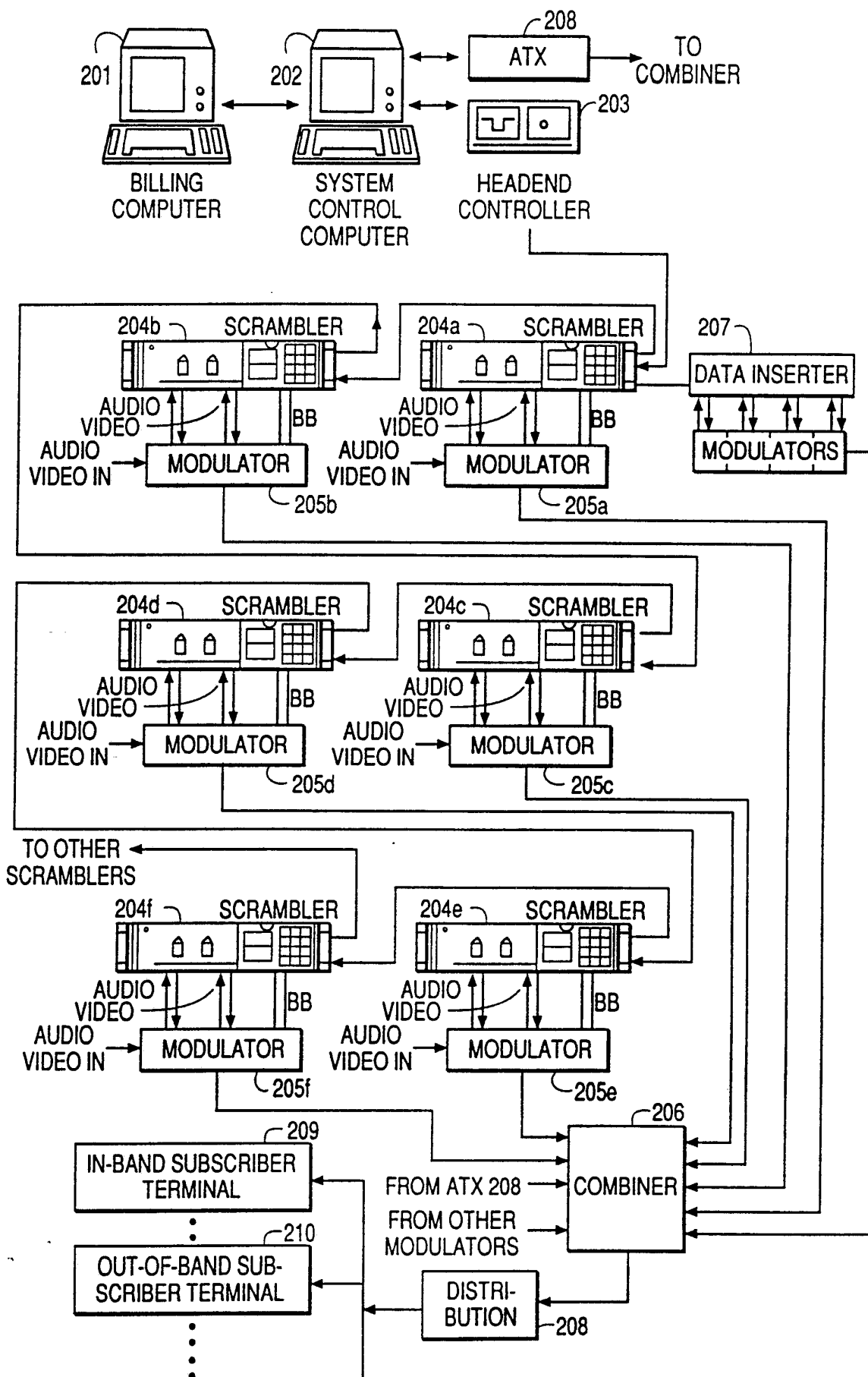

FIG. 3

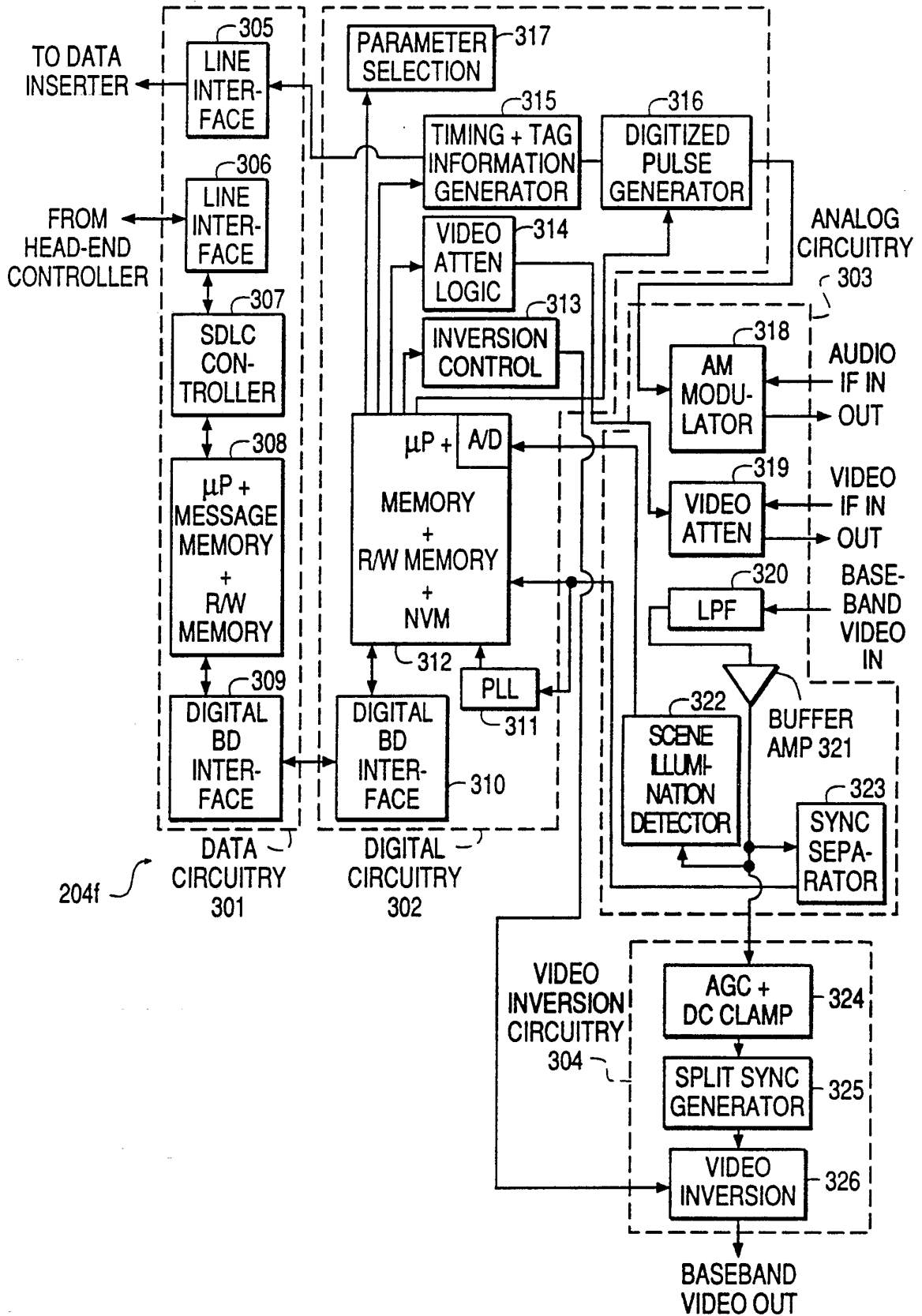

FIG. 4

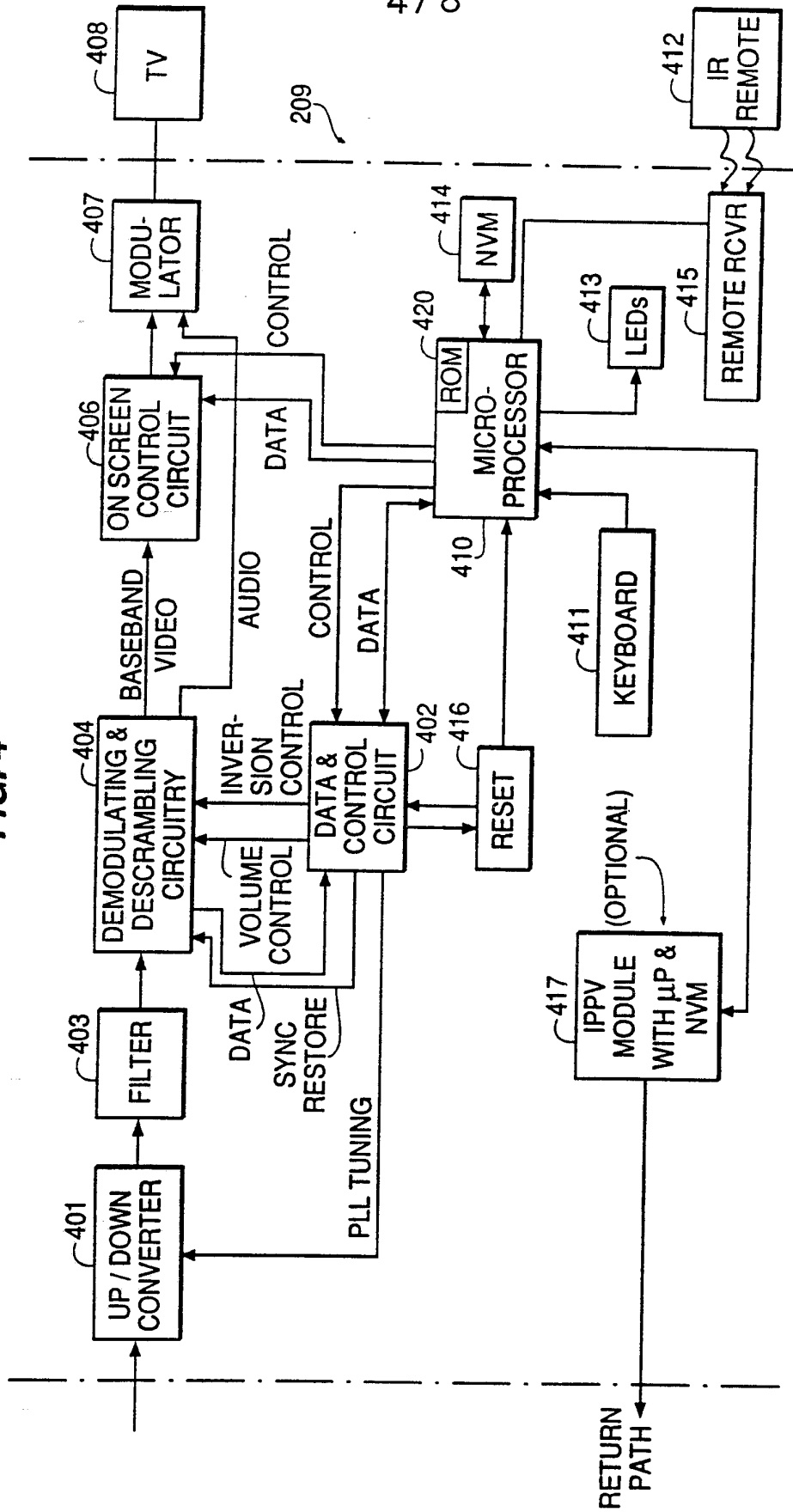

FIG. 5A(1)

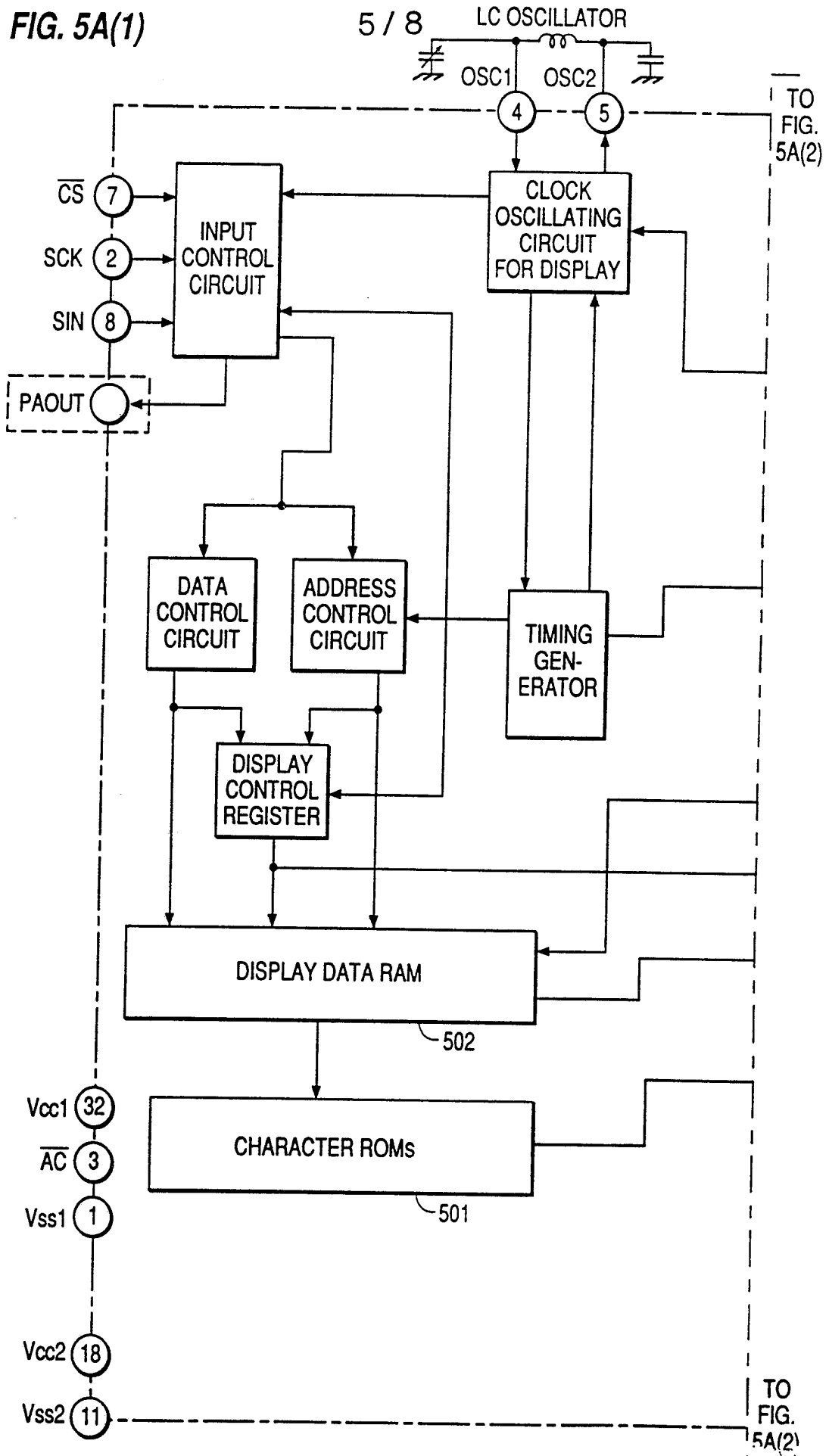
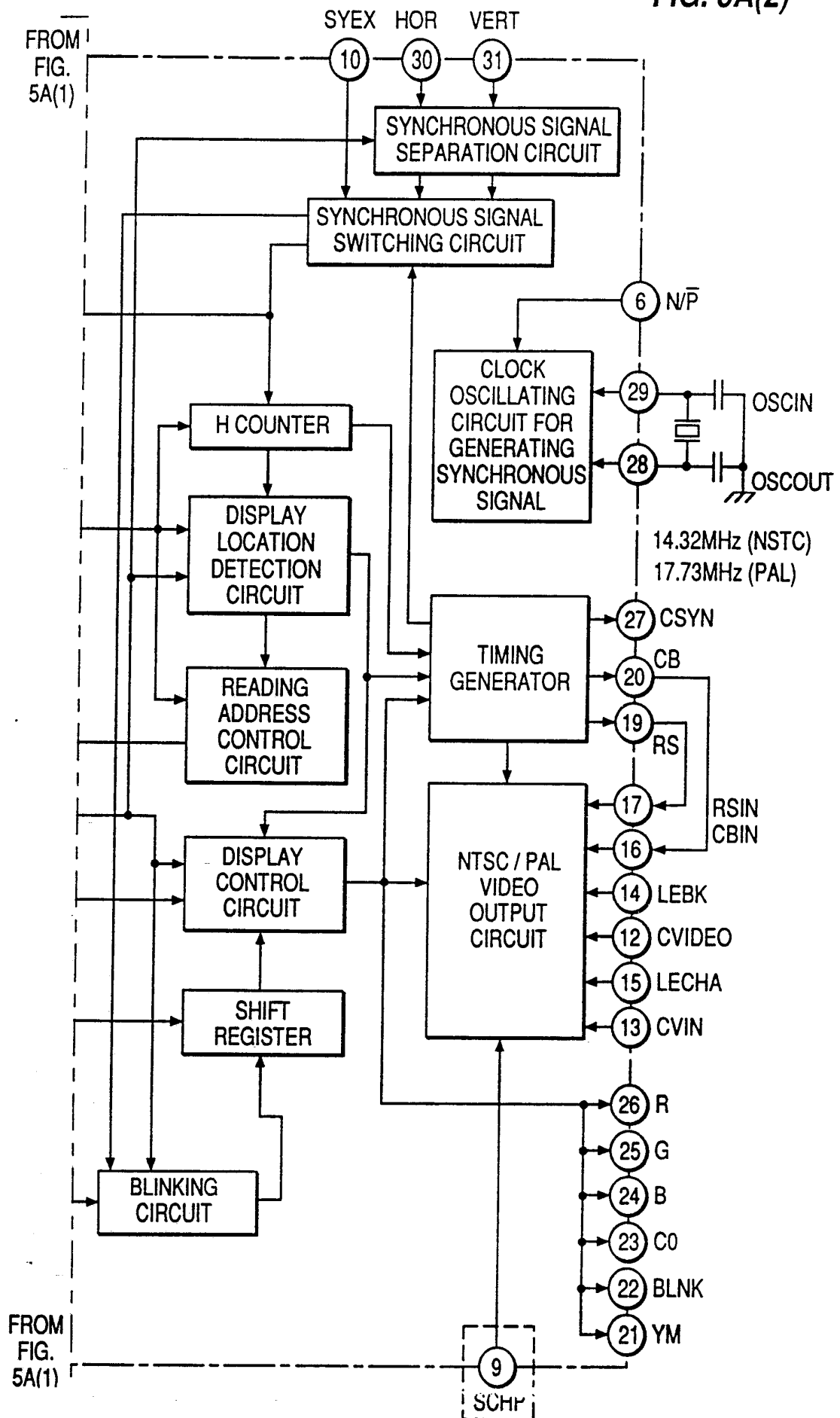

FIG. 5A(2)



CHARACTER COLOR BITS	BLINKING BIT	CHARACTER CODE
----------------------------	-----------------	-------------------

**FIG. 5B**

DISPLAY NUMBER	SCREEN NUMBER	LAST SCREEN FLAG	SEQUENCE NUMBER	CHARACTERS
-------------------	------------------	------------------------	--------------------	------------

**FIG. 6A**

ID	ON SCREEN ALERT DATA	DISPLAY NUMBER	BACKGROUND COLOR	TUNING DATA	MESSAGE EXPIRATION	ADDRESS DATA
----	-------------------------	-------------------	---------------------	----------------	-----------------------	-----------------

**FIG. 6B**

1	2	3	4	5	6	7	8	9	10	11	12	13	14	15	16	17	18	19	20	21	22	23	24
25	26	27	28	29	30	31	32	33	34	35	36	37	38	39	40	41	42	43	44	45	46	47	48
49	50	51	52	53	54	55	56	57	58	59	60	61	62	63	64	65	66	67	68	69	70	71	72
73	74	75	76	77	78	79	80	81	82	83	84	85	86	87	88	89	90	91	92	93	94	95	96
97	98	99	100	101	102	103	104	105	106	107	108	109	110	111	112	113	114	115	116	117	118	119	120
121	122	123	124	125	126	127	128	129	130	131	132	133	134	135	136	137	138	139	140	141	142	143	144
145	146	147	148	149	150	151	152	153	154	155	156	157	158	159	160	161	162	163	164	165	166	167	168
169	170	171	172	173	174	175	176	177	178	179	180	181	182	183	184	185	186	187	188	189	190	191	192
193	194	195	196	197	198	199	200	201	202	203	204	205	206	207	208	209	210	211	212	213	214	215	216
217	218	219	220	221	222	223	224	225	226	227	228	229	230	231	232	233	234	235	236	237	238	239	240

FIG. 5C

## INTERNATIONAL SEARCH REPORT

PCT/US 92/10109

International Application No

I. CLASSIFICATION OF SUBJECT MATTER (if several classification symbols apply, indicate all) <sup>6</sup>		
According to International Patent Classification (IPC) or to both National Classification and IPC Int.Cl. 5 H04N7/16		
II. FIELDS SEARCHED		
Minimum Documentation Searched <sup>7</sup>		
Classification System	Classification Symbols	
Int.Cl. 5	H04N	
Documentation Searched other than Minimum Documentation to the Extent that such Documents are Included in the Fields Searched <sup>8</sup>		
III. DOCUMENTS CONSIDERED TO BE RELEVANT <sup>9</sup>		
Category <sup>10</sup>	Citation of Document, <sup>11</sup> with indication, where appropriate, of the relevant passages <sup>12</sup>	Relevant to Claim No. <sup>13</sup>
X	WO,A,9 013 207 (SCIENTIFIC- ATLANTA INC) 1 November 1990	1,2
A	see page 21, line 18 - page 22, line 26 see figures 1,2,9,12	3,4
Y	WO,A,9 013 100 (SCIENTIFIC- ATLANTA INC.) 1 November 1990	1,2
X	see page 12, line 11 - page 13, line 5 see page 19, line 18 - page 20, line 18 see page 23, line 3 - line 23 see page 24, line 18 - page 26, line 4 see page 29, line 3 - line 13 see figures 1,2,8	3,4
	---	-/--
<p><sup>10</sup> Special categories of cited documents:</p> <p>"A" document defining the general state of the art which is not considered to be of particular relevance</p> <p>"E" earlier document but published on or after the international filing date</p> <p>"L" document which may throw doubts on priority claim(s) or which is cited to establish the publication date of another citation or other special reason (as specified)</p> <p>"O" document referring to an oral disclosure, use, exhibition or other means</p> <p>"P" document published prior to the international filing date but later than the priority date claimed</p> <p>"T" later document published after the international filing date or priority date and not in conflict with the application but cited to understand the principle or theory underlying the invention</p> <p>"X" document of particular relevance; the claimed invention cannot be considered novel or cannot be considered to involve an inventive step</p> <p>"Y" document of particular relevance; the claimed invention cannot be considered to involve an inventive step when the document is combined with one or more other such documents, such combination being obvious to a person skilled in the art.</p> <p>"&amp;" document member of the same patent family</p>		
IV. CERTIFICATION		
Date of the Actual Completion of the International Search 23 FEBRUARY 1993		Date of Mailing of this International Search Report 05.03.93
International Searching Authority EUROPEAN PATENT OFFICE		Signature of Authorized Officer VAN DER ZAAL R.



III. DOCUMENTS CONSIDERED TO BE RELEVANT (CONTINUED FROM THE SECOND SHEET)		Relevant to Claim No.
Category <sup>o</sup>	Citation of Document, with indication, where appropriate, of the relevant passages	
Y	EP,A,0 178 866 (SONY) 23 April 1986	1,2
A	see page 1, line 2 - line 30 see page 2, line 10 - page 3, line 30 see page 5, line 6 - page 8, line 7 see figures 1-8	3,4
A	--- GB,A,2 232 031 (PIONEER) 28 November 1990 see the whole document	1-4
A	--- WO,A,9 007 847 (SCIENTIFIC ATLANTA INC) 12 July 1990 -----	

**ANNEX TO THE INTERNATIONAL SEARCH REPORT  
ON INTERNATIONAL PATENT APPLICATION NO.**

US 9210109  
SA 67450

This annex lists the patent family members relating to the patent documents cited in the above-mentioned international search report.  
The members are as contained in the European Patent Office EDP file on  
The European Patent Office is in no way liable for these particulars which are merely given for the purpose of information. 23/02/93

Patent document cited in search report	Publication date	Patent family member(s)	Publication date
WO-A-9013207	01-11-90	US-A- 5001554	19-03-91
		AU-A- 5540990	16-11-90
		CA-A- 2014794	20-10-90
		CN-A- 1047597	05-12-90
-----			
WO-A-9013100	01-11-90	US-A- 4994908	19-02-91
		AU-A- 5565190	16-11-90
		CA-A- 2014795	20-10-90
		CN-A- 1047950	19-12-90
-----			
EP-A-0178866	23-04-86	JP-A- 61093739	12-05-86
		CA-A- 1271249	03-07-90
		US-A- 4896354	23-01-90
-----			
GB-A-2232031	28-11-90	JP-A- 2288571	28-11-90
-----			
WO-A-9007847	12-07-90	US-A- 4987486	22-01-91
		AU-A- 4941790	01-08-90
		CA-A- 2005804	23-06-90
		CN-A- 1047428	28-11-90
		GB-A- 2244891	11-12-91
		US-A- 5077607	31-12-91
		US-A- 5053883	01-10-91
		US-A- 4994908	19-02-91
		US-A- 5001554	19-03-91
US-A- 4991011	05-02-91		
-----			