

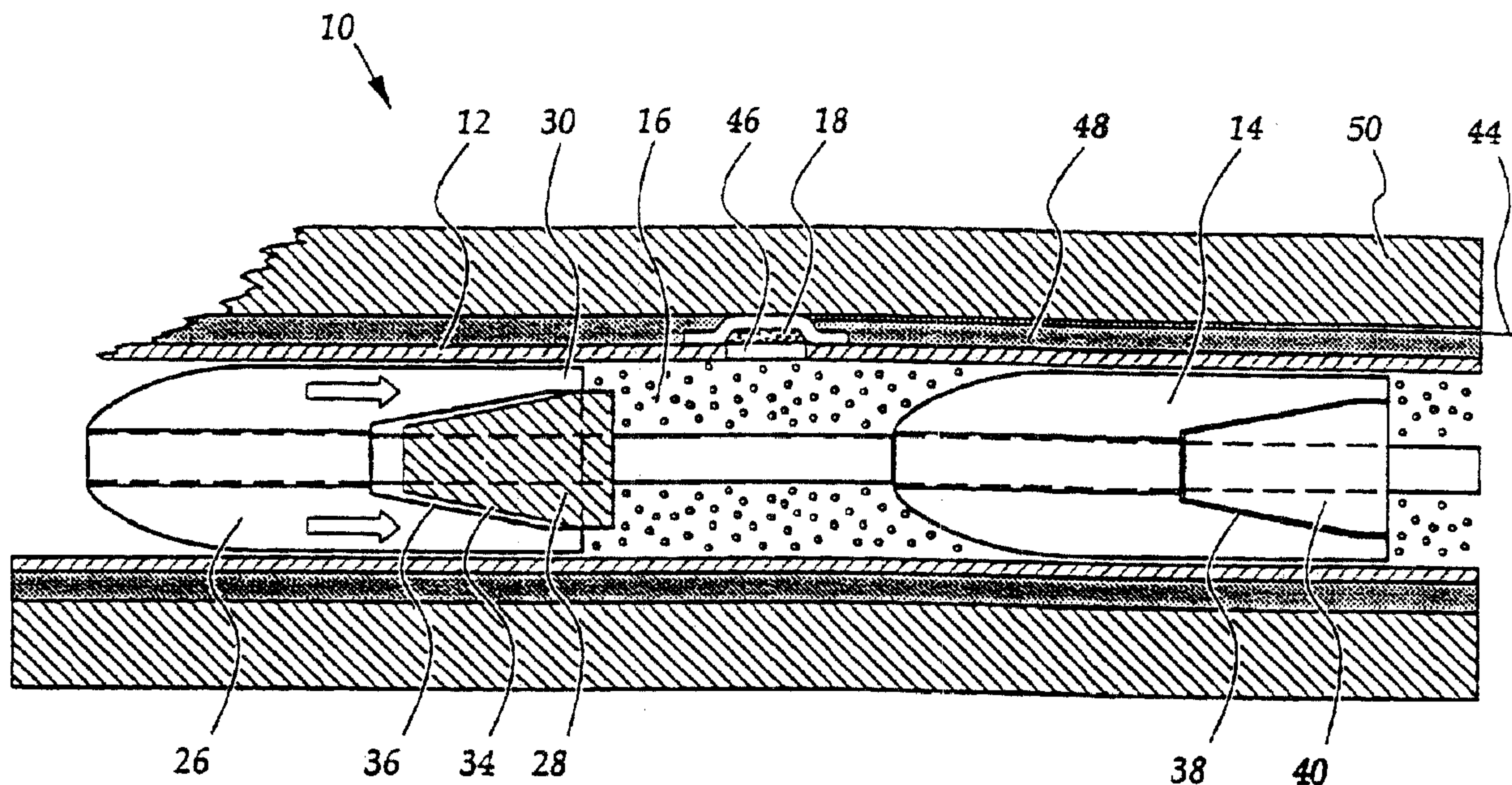

(86) Date de dépôt PCT/PCT Filing Date: 1994/03/14
 (87) Date publication PCT/PCT Publication Date: 1994/09/15
 (45) Date de délivrance/Issue Date: 2007/06/26
 (85) Entrée phase nationale/National Entry: 1995/09/08
 (86) N° demande PCT/PCT Application No.: AU 1994/000124
 (87) N° publication PCT/PCT Publication No.: 1994/020809
 (30) Priorités/Priorities: 1993/03/12 (AUPI 7773);
 1993/05/19 (AUPL 8876); 1993/09/15 (AUPM 1201);
 1993/12/09 (AUPM 2868); 1994/01/12 (AUPM 3314)

(51) Cl.Int./Int.Cl. *F42B 30/00* (2006.01),
F41A 19/65 (2006.01), *F41A 21/00* (2006.01),
F42B 5/03 (2006.01), *F42B 5/08* (2006.01)
 (72) Inventeur/Inventor:
 O'DWYER, JAMES MICHAEL, AU
 (73) Propriétaire/Owner:
 METAL STORM LIMITED, AU
 (74) Agent: GOWLING LAFLEUR HENDERSON LLP

(54) Titre : ENSEMBLE CANON
 (54) Title: A BARREL ASSEMBLY



(57) Abrégé/Abstract:

A barrel assembly (10) includes barrel (12), projectile assemblies (14) axially disposed within the barrel, propellant charges (16), ignition means (18), and control means (20). Projectile assemblies (14) are sequentially fired from the barrel. Also disclosed is an arming system, a barrel construction, means for preventing compression of the propellant charges and means for ensuring sealing between the projectile assembly and the barrel.



INTERNATIONAL APPLICATION PUBLISHED UNDER THE PATENT COOPERATION TREATY (PCT)

<p>(51) International Patent Classification⁵ : F41A 21/00, 21/06</p>	<p>A1</p>	<p>(11) International Publication Number: WO 94/20809 (43) International Publication Date: 15 September 1994 (15.09.94)</p>
---	-----------	--

(21) International Application Number: PCT/AU94/00124
 (22) International Filing Date: 14 March 1994 (14.03.94)
 (30) Priority Data:
 PL 7773 12 March 1993 (12.03.93) AU
 PL 8876 19 May 1993 (19.05.93) AU
 PM 1201 15 September 1993 (15.09.93) AU
 PM 2868 9 December 1993 (09.12.93) AU
 PM 3314 12 January 1994 (12.01.94) AU
 (71)(72) Applicant and Inventor: O'DWYER, James, Michael
 [AU/AU]; 1256 Ross River Road, Kelso, Townsville, QLD
 4814 (AU).
 (74) Agent: PIZZEY, John, Kingston; Pizzey & Company, 6/444
 Queen Street, Brisbane, QLD 4000 (AU).

(81) Designated States: AT, AU, BB, BG, BR, BY, CA, CH, CN, CZ, DE, DK, ES, FI, GB, GE, HU, JP, KG, KP, KR, KZ, LK, LU, LV, MD, MG, MN, MW, NL, NO, NZ, PL, PT, RO, RU, SD, SE, SI, SK, TJ, TT, UA, US, UZ, VN, European patent (AT, BE, CH, DE, DK, ES, FR, GB, GR, IE, IT, LU, MC, NL, PT, SE), OAPI patent (BF, BJ, CF, CG, CI, CM, GA, GN, ML, MR, NE, SN, TD, TG).

2157882

Published
 With international search report.
 Before the expiration of the time limit for amending the claims and to be republished in the event of the receipt of amendments..

(54) Title: A BARREL ASSEMBLY

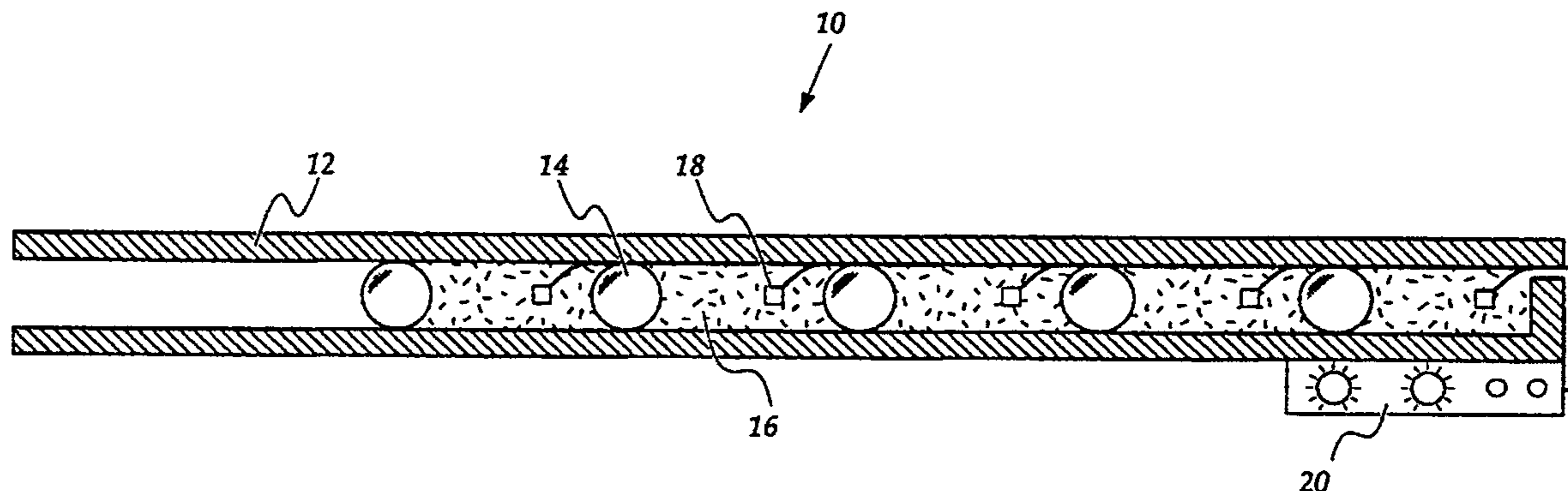

(57) Abstract
 A barrel assembly (10) includes barrel (12), projectile assemblies (14) axially disposed within the barrel, propellant charges (16), ignition means (18), and control means (20). Projectile assemblies (14) are sequentially fired from the barrel. Also disclosed is an arming system, a barrel construction, means for preventing compression of the propellant charges and means for ensuring sealing between the projectile assembly and the barrel.

2157882

1

"A BARREL ASSEMBLY"

-- BACKGROUND OF THE INVENTION --

The invention relates to firearms.

The invention has utility as an automatic, high rate of
5 fire, firearm whereby it may be used for example, as a close-
in ship-board defense against bombs, missiles or attack
aircraft for launching large numbers of projectiles within a
short period of time. The invention also has utility in hand
guns such as a rapid fire pistol or rifle which may be
10 disposable.

Currently, most firearms use cartridge ammunition which
is mechanically fed to a barrel. Such firearms have numerous
moving parts, tend to be heavy and complex, may jamb or be
unreliable, and require elaborate delivery and loading
15 systems to support the rate of fire. The rate of fire of
automatic firearms of this type is limited by the time
required to load the cartridge, seal the barrel, unseal the
barrel and eject the empty case.

More recently, firearms have begun to utilise caseless
20 ammunition which obviates the need to eject an empty case
subsequent to firing. However, these firearms retain many of
the problems of conventional firearms.

-- SUMMARY OF THE INVENTION --

The present invention aims to provide an alternative
25 system which will alleviate at least one of the disadvantages
of the prior art.

According to one aspect this invention provides a barrel
assembly including:-

- a barrel;
- 30 a plurality of projectile assemblies axially disposed
within the barrel for operative sealing engagement with the
bore of the barrel;
- discrete propellant charges for propelling respective
projectile assemblies sequentially through the muzzle of the
35 barrel;

2157882

2

ignition means for igniting the discrete propellant charges; and

control means for selectively and sequentially actuating the ignition means.

5 The ignition means may be electrical, chemical, mechanical or any other conventional primer. Conveniently, the ignition means is electrical and the control means is an electrical control adapted to provide electrical ignition pulse to the respective ignition means. Suitably the control
10 means is configured to enable a user to selectively control the rate, number, and frequency of the pulses to provide a desired firing pattern. The control means may fire the projectile assemblies singly, in pairs, or in any other combinations.

15 The projectile assembly may be round, conventionally shaped or dart-like and the fins thereof may be off-set to generate a stabilising spin as the dart is propelled from a barrel which may be a smooth-bored barrel. In addition the barrel assembly may find utility as a removable/replaceable
20 barrel of a rifle or pistol.

Alternatively the barrel assembly constitutes one of a plurality of barrel assemblies and the control means may actuate the ignition means of each of the barrel assemblies in such manner that a sequential plurality of arrays of
25 projectile assemblies are propelled in following relationship. Aiming and firing of the arrays of projectile assemblies may be controlled by a conventional radar fire control system or other known fire control systems. The individual barrel assemblies may be aimed such that the array
30 of projectile assemblies converges at a particular range to give a maximum density of projectile assemblies at that range.

Alternatively, the array of projectile assemblies may diverge to maximise coverage of an area. Thus, the average
35 separation distance at the target between the projectile

assemblies in an array can be predetermined and adjusted to suit the nature and range of the target. Of course, the individual barrel assemblies may be fired randomly or independently of the other barrel assemblies.

5 The plurality of projectile assemblies may be disposed in a continuous abutting relationship throughout the barrel either by the projectile assemblies abutting one another or abutting column means intermediate the projectile assemblies to form a compression resistant column able to resist
10 compression of the projectile assemblies or propelling charges associated therewith due to pressure generated by the firing of the leading projectile assemblies.

The propelling charges may be either solid or granular and compression of either may be an undesirable, moreover,
15 movement of the projectile assemblies relative to the barrel may cause misalignment of the ignition means with their respective propellant charges.

It is preferred that the ignition means be disposed at the leading end of the propellant charge so as to minimise
20 possible energy loss in accelerating the front portion of the propellant charge.

It is preferred that each projectile assembly includes a projectile head and extension means for at least partly defining a propellant space. Preferably, the extension means
25 includes a spacer assembly which extends rearwardly from the projectile head and abuts an adjacent projectile assembly.

In one embodiment, the spacer assembly extends through the propellant space and the projectile head whereby compressive loads are transmitted directly through abutting
30 adjacent spacer assemblies. In such embodiment the spacer assembly may add support to the extension means which may be a thin cylindrical rear portion of the projectile head. Furthermore the extension means may form an operative sealing contact with the bore of the barrel to prevent burn leakage
35 past the projectile head.

2157882

4

It is preferred that the spacer assembly includes a rigid collar which extends outwardly to engage a thin cylindrical rear portion of the malleable projectile head in operative sealing contact with the bore of the barrel such
5 that axially compressive loads are transmitted directly between spacer assemblies thereby avoiding deformation of the malleable projectile head.

In another embodiment, complementary wedging surfaces are disposed on the spacer assembly and projectile head
10 respectively whereby the projectile head is urged into engagement with the bore of the barrel in response to relative axial compression between the spacer means and the projectile head. In such arrangement the projectile head and spacer assembly may be loaded into the barrel and thereafter
15 an axial displacement is caused to ensure good sealing between the projectile head and barrel. Suitably the extension means is urged into engagement with the bore of the barrel.

Preferably, the projectile head defines a tapered
20 aperture at its rearward end into which is received a complementary tapered spigot disposed on the leading end of the spacer assembly, wherein relative axial movement between the projectile head and the complementary tapered spigot causes a radially expanding force to be applied to the
25 projectile head.

The barrel may be non-metallic and the bore of the barrel may include recesses which may fully or partly accommodate the ignition means. In this situation the barrel houses electrical conductors which facilitate electrical
30 communication between the control means and ignition means. This arrangement may be utilised for disposable barrel assemblies which have a limited firing life and the ignition means and control wire or wires therefor can be integrally manufactured with the barrel.

35 In an alternative arrangement, a barrel assembly

includes ignition apertures in the barrel and the ignition means are disposed outside the barrel and adjacent the apertures. The barrel may be surrounded by a non-metallic outer barrel which may include recesses adapted to
5 accommodate the ignition means. The outer barrel may also house electrical conductors which facilitate electrical communication between the control means and ignition means. The outer barrel may be formed as a laminated plastics barrel which may include a printed circuit laminate for the ignition
10 means.

Both of the above arrangements lend themselves to a modular or disposable construction. The barrel assemblies may be adapted for firing as is, or may be adapted for mounting within a housing.

15 For safety, the barrel assembly may include an arming switch associated with each ignition means which is closed in response to the preceding projectile assembly being discharged. Preferably, the arming switch is closed by biasing means which are normally resisted by the preceding
20 projectile assembly. In a preferred embodiment, the projectile head and spacer assembly each constitute switch contacts which are normally electrically isolated from each other and wherein an electrical circuit between the barrel and spacer body is completed in response to the preceding
25 projectile assembly being discharged. In this arrangement, the barrel, which is in electrical contact with the projectile head, is also in contact with one of the electrodes.

In a further aspect this invention resides broadly in a
30 method of defending an airspace, including:-

providing a plurality of barrel assemblies substantially as defined above, and

sequentially igniting propellant charges in the barrel assemblies in rapid succession to propel sequential arrays of
35 projectile assemblies into the airspace.

2157882

6

-- BRIEF DESCRIPTION OF THE DRAWINGS --

In order that this invention may be more readily understood and put into practical effect, reference will now be made to the accompanying drawings which illustrate
5 typical embodiments of the invention and wherein:-

FIG. 1 is a sectional and schematic view of an embodiment of a barrel assembly according to the invention;

10 FIG. 2 schematically illustrates the concept of a plurality of barrel assemblies according to the invention being massed in pods;

FIG. 3 is a schematic view of arrays of projectile assemblies being fired from the pods of FIG. 2;

15 FIG. 4 is a sectional and schematic view of an embodiment of a barrel assembly according to the invention wherein the projectile assembly is in the form of a dart;

20 FIG. 5 is a sectional and schematic view of another embodiment of a barrel assembly according to the invention;

FIG. 6 is a sectional and schematic view of another embodiment of a barrel assembly according to the invention;

25 FIG. 7 is a sectional and schematic view of another embodiment of a barrel assembly according to the invention;

FIG. 8 is a sectional and schematic view of another embodiment of a barrel assembly according to the invention;

30 FIG. 9 is a sectional and schematic view of another embodiment of a barrel assembly according to the invention;

35 FIG. 10 is a sectional and schematic view of another embodiment of a barrel assembly according to the invention;

2157882

7

FIG. 11 is a diagrammatic representation of a pistol made in accordance with the present invention, and FIGS. 12 and 13 illustrate an alternate form of projectile.

5 -- DESCRIPTION OF THE PREFERRED EMBODIMENT --

Referring to FIG. 1, there is illustrated a barrel assembly 10 including a barrel 12, a plurality of spherical projectiles 14 axially disposed within barrel 12 for operative sealing engagement with the bore of barrel 12, discrete propellant charges 16 disposed between adjacent projectile assemblies 14 for propelling the respective projectile assemblies 14 individually and sequentially through the muzzle of barrel 12, ignition means 18 for igniting discrete propellant charges 16, and control means 20 for selectively and sequentially actuating ignition means 18.

In use, the leading projectile assembly 14 is propelled in response to ignition of the leading propellant charge 16 by the leading ignition means 18. Thereafter the following projectile assemblies are sequentially propelled in like fashion. There is no ammunition delivery system or moving parts, and the firing rate is practically limited only by the time taken for each projectile assembly to exit the barrel.

The control means may have time delay means to control the rapidity of fire and or timing means permitting a selected number of sequential ignitions in response to each manual actuation of the ignition means, such as by squeezing a trigger. A mode switch may be associated with the control means to enable a user to select the form of firing, ie full barrel discharge, short bursts of rapid fire, sequential fire of a selected number of projectiles, single shot firing per actuation etc. Integrated circuit electronic control means are preferably utilised as the control means and may be manufactured as part of the barrel assembly.

Referring to FIG. 2, the barrel assembly constitutes one of a plurality of barrel assemblies and the control means

2157882

8

actuates the ignition means of each of the barrel assemblies in such manner that a sequential plurality of arrays of projectile assemblies are propelled in following relationship as shown in FIG. 3. The plurality of barrel assemblies forms a pod 22 and a plurality of pods are mounted on a trainable mount 24. The aiming and firing of the barrel assemblies is controlled by a radar fire control system 25 or other conventional system.

In one form, each barrel is 2.25 metres long and has an outside diameter of 20 mm. The combined propelling charge/projectile assembly length is 50 mm. Leaving 0.25 metres of the barrel free, 40 projectile assemblies together with their associated propellant charges can be pre-loaded into the barrel. The pod has a cross-sectional dimension of 0.75 metres by 0.75 metres for example and therefore accommodates approximately 1200 barrel assemblies. Thus, a pod can be pre-loaded with 48000 projectile assemblies.

This enables significant fire-power to be associated with a relatively small weapon and a very high discharge rate to be achieved, bearing in mind the firing rate of each individual barrel assembly may be significantly in excess of the rate achievable by conventional automatic firearms. The barrel assemblies may be formed as a relatively lightweight honeycomb structure which will be very stiff and if desired the barrels may be arranged to focus at a point relatively close to the weapon with a view to counteracting the spreading tendencies produced by the expansion of the hot explosion gases radiating in an outwards direction. Alternatively a box-like baffle could be used to prevent the immediate outward spread of the gases. This baffle may be slidably supported about the outer barrel section for extension past the end of the barrels during firing. A further manner of alleviating this perceived effect would be to slightly stagger the firing of the projectiles.

Referring to the embodiments of FIGS. 4 to 10,

2157882

9

projectile assemblies 14 are disposed in axial abutting relationship to form a compression resistant column. Axially compressive loads are created by the pressures generated in the barrel by the propulsion of preceding projectile assemblies. Compression can result in an alteration of the burn rate of a propelling charge, misalignment of ignition means with respective propelling charges or even premature ignition of propelling charge.

Each projectile assembly 14 includes a projectile head 26 and means for defining a propellant space in the form of spacer assembly 28 which extends axially and rearwardly from projectile head 26 and abuts an adjacent projectile assembly 14.

Projectile head 26 is formed from a heavy malleable material such as lead to facilitate operative sealing with barrel 12, and spacer assembly 28 is formed of a rigid material such as steel.

In the embodiment of FIG. 5, the spacer assembly 28 takes the form of a cylinder axially extending from projectile head 26. The interior of the cylinder accommodates propellant charge 16 and is structurally reinforced to prevent excessive radial expansion. The end of the cylinder is adapted to abut the leading end of the subsequent projectile assembly 14.

Referring to the embodiments of FIGS. 6 and 7, spacer assembly 28 extends through projectile head 26 to the leading end of projectile head 26 whereby compressive loads are transmitted directly between adjacent spacer assemblies 28. Spacer assembly 28 supports a thin cylindrical rear portion 30 of projectile head 26 in operative sealing contact with the bore of barrel 12. Specifically, spacer assembly 28 includes a radially outwardly extending collar flange 32 which supports thin cylindrical rear portion 30 of projectile head 26 in operative sealing contact with the bore of barrel 12.

2157882

10

Referring to the embodiments of FIGS. 9 and 10, complementary wedging surfaces 34, 36 are disposed on spacer assembly 28 and projectile head 26 respectively whereby thin cylindrical rear portion 30 of projectile head 26 is urged into engagement with the bore of barrel 12 in response to an axially compressive load being applied to projectile assembly 14. Projectile head 26 defines a tapered aperture 38 at its rearward end into which is received a complementary tapered spigot 40 disposed on the leading end of spacer assembly 28. Relative axial movement between tapered aperture 38 and complementary tapered spigot 40 causes a radially expanding force to be applied to thin cylindrical rear portion 30 of projectile head 26.

In the embodiment of FIG. 7, barrel 12 is non-metallic and the bore of the barrel includes recesses 42 which at least partly accommodate ignition means 18. Barrel 12 may be formed of kevlar, carbon fibre, glass reinforced polymer or the like. Thus, the barrel assembly may be lightweight and disposable. Barrel 12 houses electrical conductors 44 which facilitate electrical communication between the control means and ignition means.

In the embodiments of FIGS. 8 and 9, barrel 12 includes ignition apertures 46 and ignition means 18 are disposed outside the barrel and adjacent the apertures. Barrel 12 is surrounded by a non-metallic outer barrel 48, the bore of the outer barrel including recesses adapted to at least partly accommodate the ignition means. The barrel assembly may be slidably received in sheath 50. Outer barrel 48 houses electrical conductors 44 which facilitate electrical communication between the control means and ignition means 18.

Referring to FIG. 10, arming switch 52 associated with ignition means 18 is closed in response to the preceding projectile assembly being discharged. Specifically, arming switch is closed by biasing means 54 once the preceding

2157882

11

projectile assembly has been propelled. Projectile head 26 and spacer assembly 28 each constitute switch contacts which are normally electrically isolated from each other by insulating layer 56. An electrical circuit between barrel 12 and spacer assembly 28 is completed when arming switch 52 closes in response to the preceding projectile assembly being discharged. The ignition means 18 is thus armed only when the preceding projectile assembly has been discharged.

A four barrel hand gun 60 is illustrated in FIG. 11. The barrels of the four barrel set 61, are arranged in a square formation, and are fed by a matching replaceable four barrel magazine block 62 which slots into a cutout 63 at the base of the barrel set 61. The barrel set 61 is formed integrally with the handgrip 64 which contains the electronic controls for the ignition means.

The four barrel magazine block 62 is loaded with 5 rounds per barrel, which number may of course be varied depending on the size of the block and the size of the round. In this embodiment the magazine block 62 contains twenty rounds.

A variable fire rate and pattern switch 66, is provided for selectively controlling the electronic ignition circuits within the magazine block 62 which connect electrically with the circuits in the hand gun via contacts which meet when the magazine block 62 is slid into position. The switch 66 may be adjusted for electronic control to enable a user to fire individual rounds with each action of the trigger 65, up to four rounds simultaneously, or all rounds automatically on all barrels. A safety catch 68 may also be provided for electrically disabling the weapon. Preferably the cartridges are disposable and may be provided in different formats so that a user may select and/or quickly change the type of rounds to be fired.

The projectiles for use with the above described embodiments may be provided with external flights or spiral

2157882

12

- ridges as illustrated in FIGS. 12 and 13. The ridges 70 are provided on the nose of the projectile to impart spin during flight. In the form illustrated a 7.62mm bullet 71 has four spiraling ridges 70 radiating from the nose of the bullet.
- 5 The ridges are of an average height of 1.5mm and extend the length of the nose of the bullet, but not along the side of the bullet. The pitch is suitably formed as to provide a single revolution of the bullet about its longitudinal axis for every meter travelled.
- 10 Of course two or more spiraling ridges, spaced evenly around the bullet nose may be utilised if desired. Furthermore the height of the ridges, the length of the ridges, the pitch or degree of spiraling, the geometric curve form of the spiral, may be varied to suit the desired flight
- 15 characteristics. The ridges may also extend along the side of the bullet. The cross section profile of the spiral ridges may be relatively flat, or steep according to the intended use of the ammunition, and the desired degree of reaction to the airflow.
- 20 As illustrated in FIG. 13, the ridges 70 may have a steep leading face 72, which offers resistance to the airflow over the bullet, and causes the bullet to rotate, a flat top portion 73 and trailing faces 74 which slope gently to the surface of the bullet.
- 25 Such ammunition may also be used in rifled barrel weapons to advantage. Also as the spirals on the bullet would assist in producing the spin during firing, the normal pressure applied by the edge of the rifling lands against the soft metal of the bullet would be reduced. Therefore the
- 30 bullet would not require the rifling to cut as long a track along the side of the bullet. Rather, the small expanding band of the Minie' gas sealing system would then be adequate to assist with spin acceleration. On impact with soft targets, the spiral bullet of the present invention would
- 35 tend to react to the increased pressure on the ridges by

2157882

13

maintaining a high rate of twist, as it progresses through the target material.

It will of course be realised that the above has been given only by way of illustrative example of the invention, 5 and that all such modifications and variations thereto as would be apparent to persons skilled in the art are deemed to fall within the broad ambit and scope of the invention as is herein set forth.

What is claimed is:

1. A projectile for a barrel assembly containing multiple projectiles, having a spacer and an expandable head surrounding the spacer, whereby when in the barrel, upon rearward movement of the head with respect to the spacer, complementary portions of the head and the spacer interact to expand the head to form a seal with the bore of the barrel.
2. A projectile according to claim 1 wherein the complementary portions of the head and the spacer include substantially conical surfaces tapered towards the front of the barrel.
3. A projectile according to claim 1 wherein the spacer has a nose portion, a central portion and a tail portion, and the head surrounds the nose and central portions.
4. A projectile according to claim 3 wherein the central portion is the complementary portion that interacts with the head to form the seal.
5. A projectile according to claim 3 wherein the head is retained on the projectile by interaction with the central portion.
6. A projectile according to claim 3 wherein the nose and tail portions are substantially cylindrical and align with the axis of the barrel.
7. A projectile according to claim 3 wherein, when in the barrel, the nose and tail portions respectively abut tail and nose portions of leading and trailing projectiles.
8. A projectile according to claim 1 wherein the head has an outer surface that interacts with an inner surface of the barrel to form the seal.
9. A projectile according to claim 3 wherein the tail portion has a length determined by a volume of propellant required in the barrel to propel the projectile from the barrel.
10. A method of sealing a projectile in a barrel, including:

providing the projectile with a spacer, a propellant charge and a head surrounding the spacer,

applying a force to the head directed axially down the barrel,

maintaining the spacer substantially rigid within the barrel, and

expanding the head radially on the spacer into a sealing contact with the bore of the barrel.

11. A method according to claim 10 further including aligning a plurality of projectiles in the barrel having spacers in nose to tail contact.

12. A method according to claim 10 wherein the propellant charge is provided in a volume behind the head and determined by the spacer.

13. A method according to claim 10 further including relaxing the head and removing the sealing contact when firing the projectile from the barrel.

14. A barrel assembly having a barrel with a plurality of projectiles aligned nose to tail for sequential firing from the barrel, each projectile having a spacer, a propellant charge and an expandable head surrounding the spacer, each head having been expanded into sealing contact with the bore of the barrel by rearward movement of the head with respect to the spacer.

15. An assembly according to claim 14 wherein the propellant charges are located in the barrel behind their respective heads by respective spacers.

16. An assembly according to claim 14 wherein the projectiles are aligned in the barrel by their respective spacers.

17. An assembly according to claim 14 further having an ignition system for firing the projectiles sequentially from the barrel.

18. A method of firing projectiles from a barrel, including:

providing each projectile with a spacer and a head surrounding the spacer,
aligning the projectiles axially within the barrel with respective propellant charges,
exerting a force down the barrel to move the heads rearwards over their respective
spacers,

expanding the heads as a result of the respective movement of the heads,
forming multiple seals between the heads and the barrel as result of the respective
expansions, and

firing the projectiles sequentially from the barrel.

19. A method according to claim 18 wherein the force down the barrel is exerted on the
projectiles by reaction to firing of the propellant charges.

20. A method according to claim 18 wherein the force down the barrel is exerted before
the projectiles are fired.

21. A method according to claim 18 wherein expansion of each head is caused by
interaction between complementary surfaces on the head and the respective spacer.

22. A method according to claim 21 wherein the complementary surfaces are tapered
towards the front of the barrel.

23. A method according to claim 18 wherein the propellant charges are provided
between the projectiles in volumes determined by respective spacers.

1/9

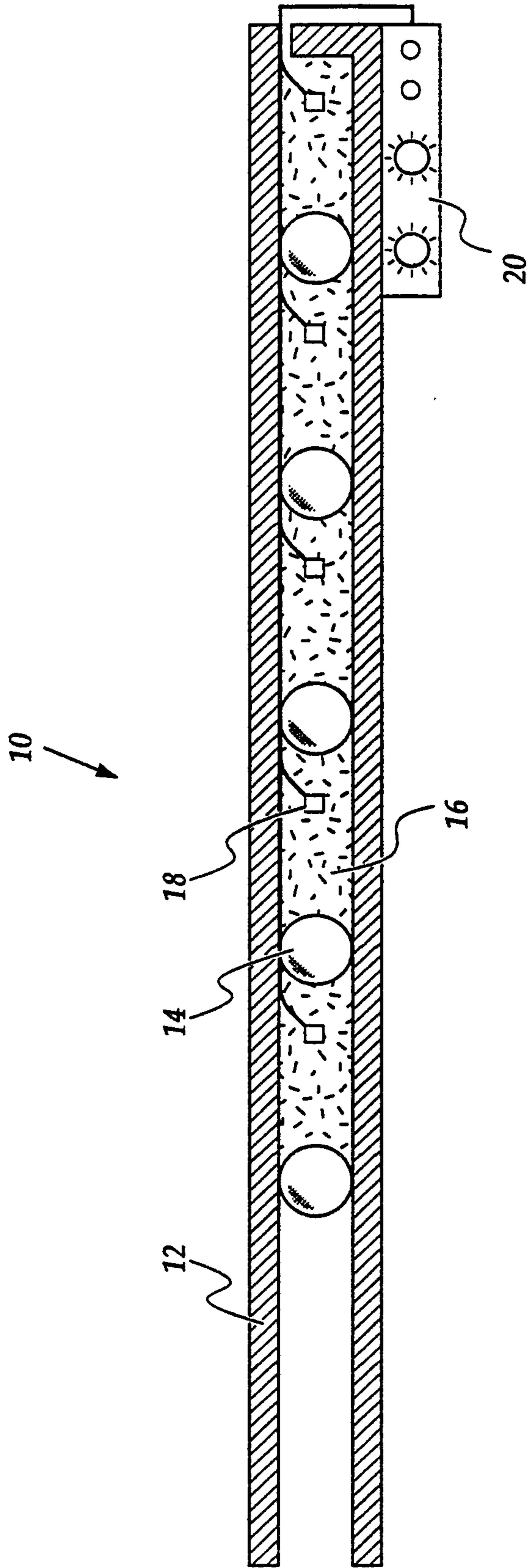

Figure 1.

2157882

2/9

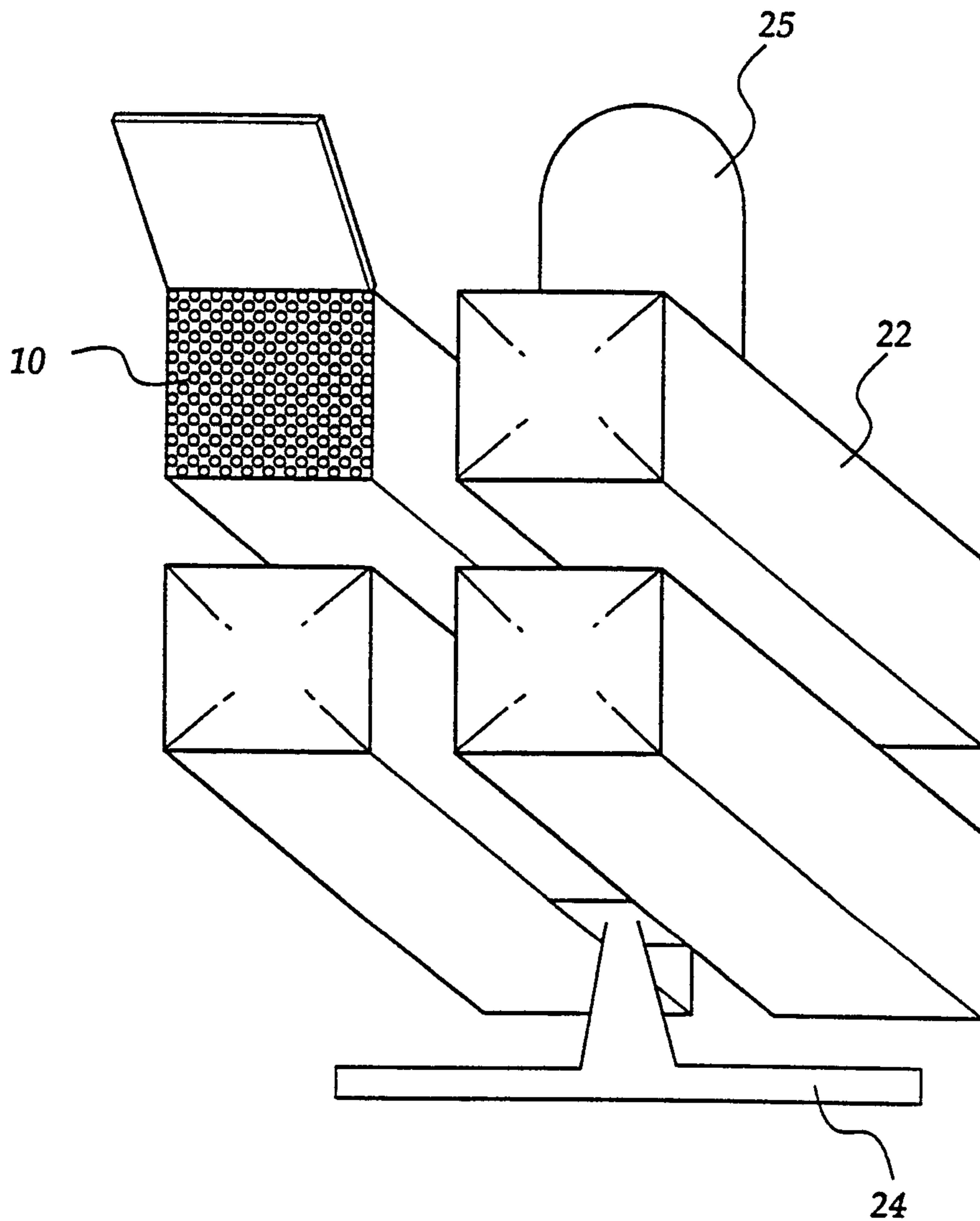

Figure 2.

3/9

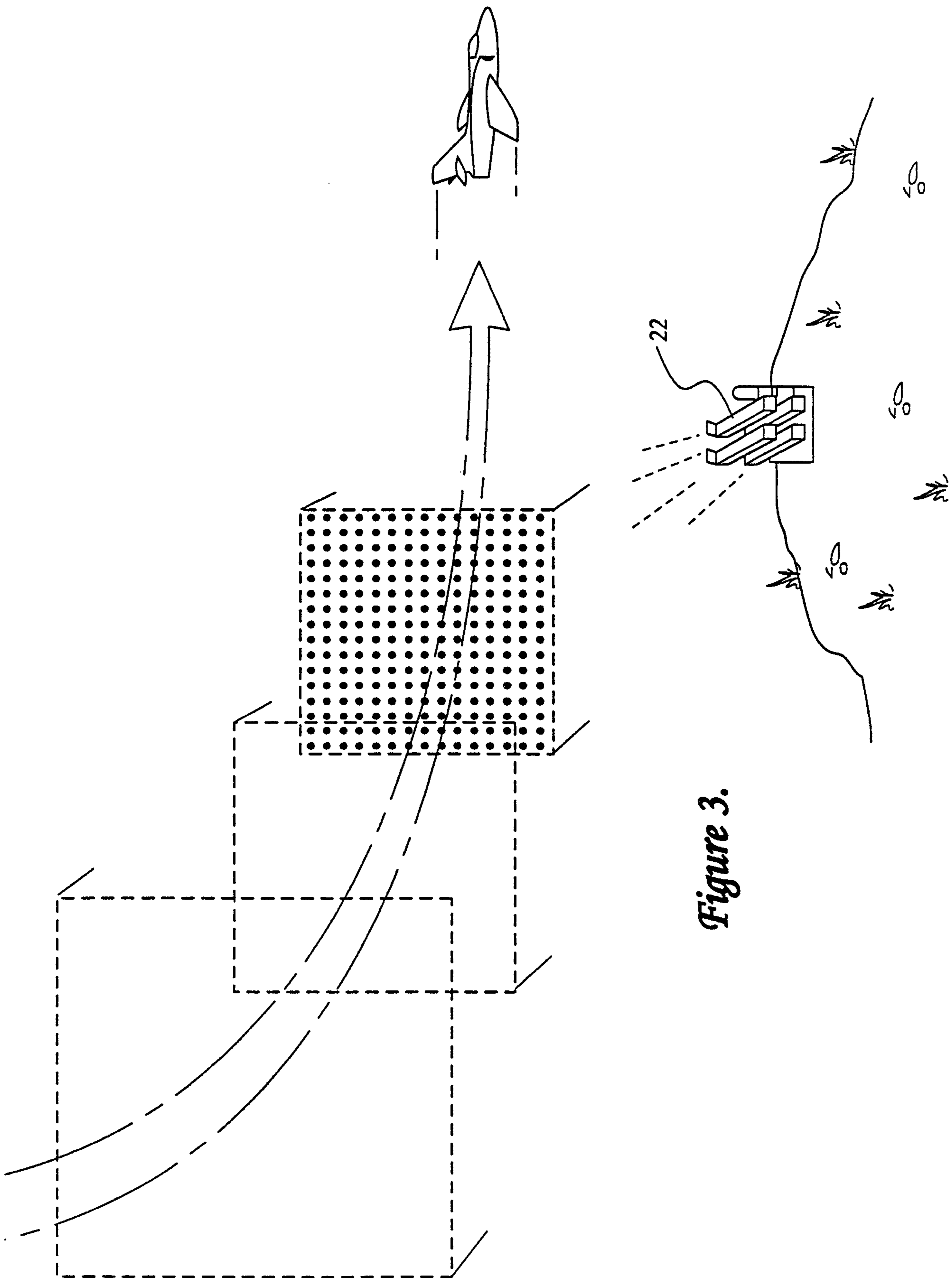

Figure 3.

4/9

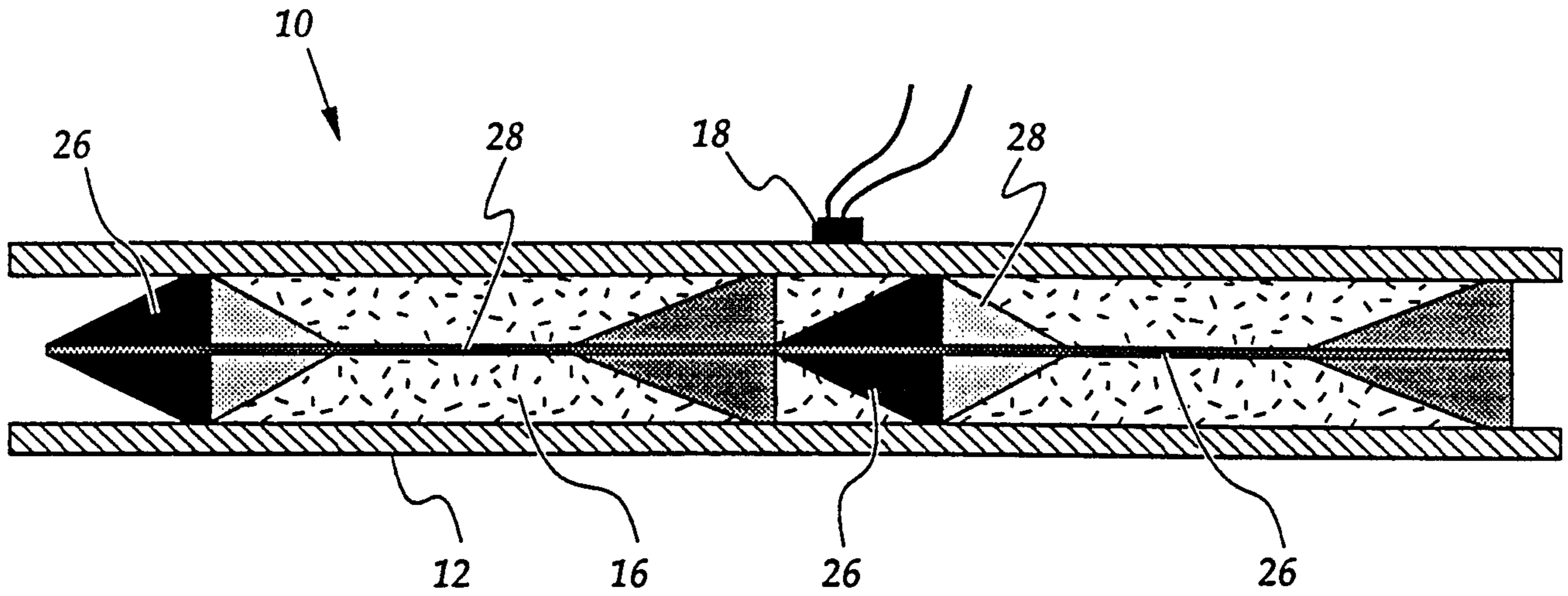

Figure 4.

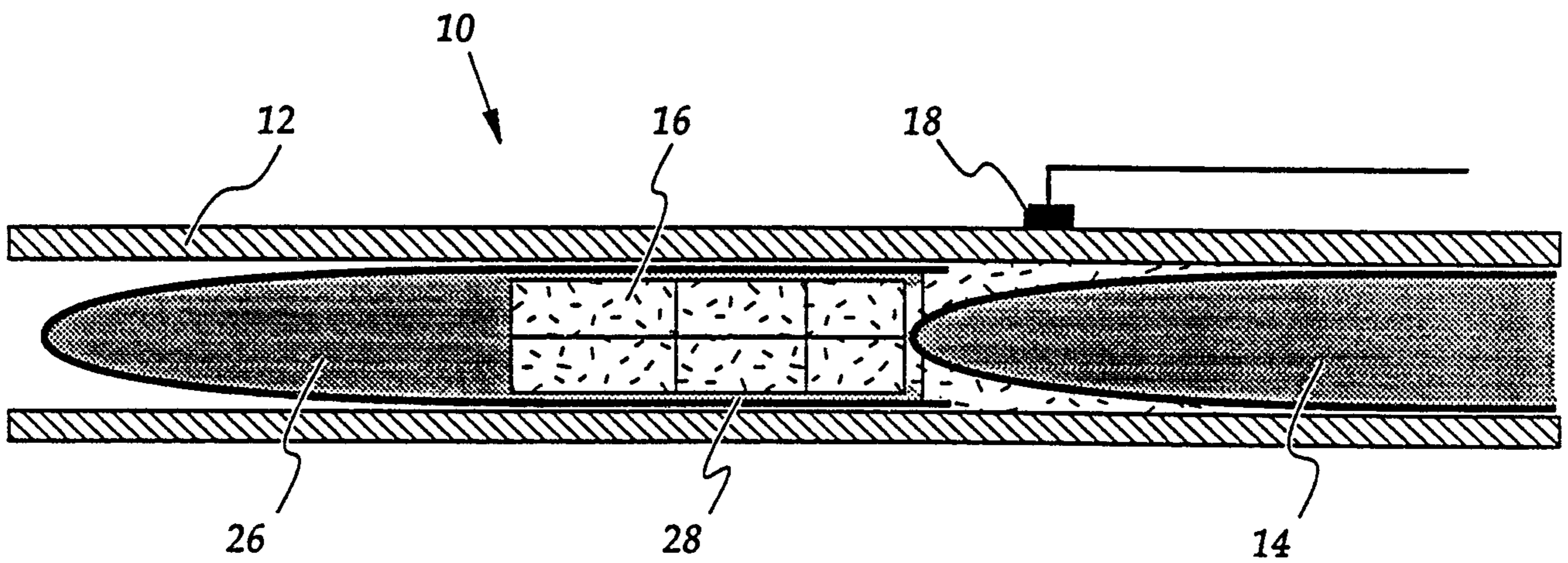

Figure 5.

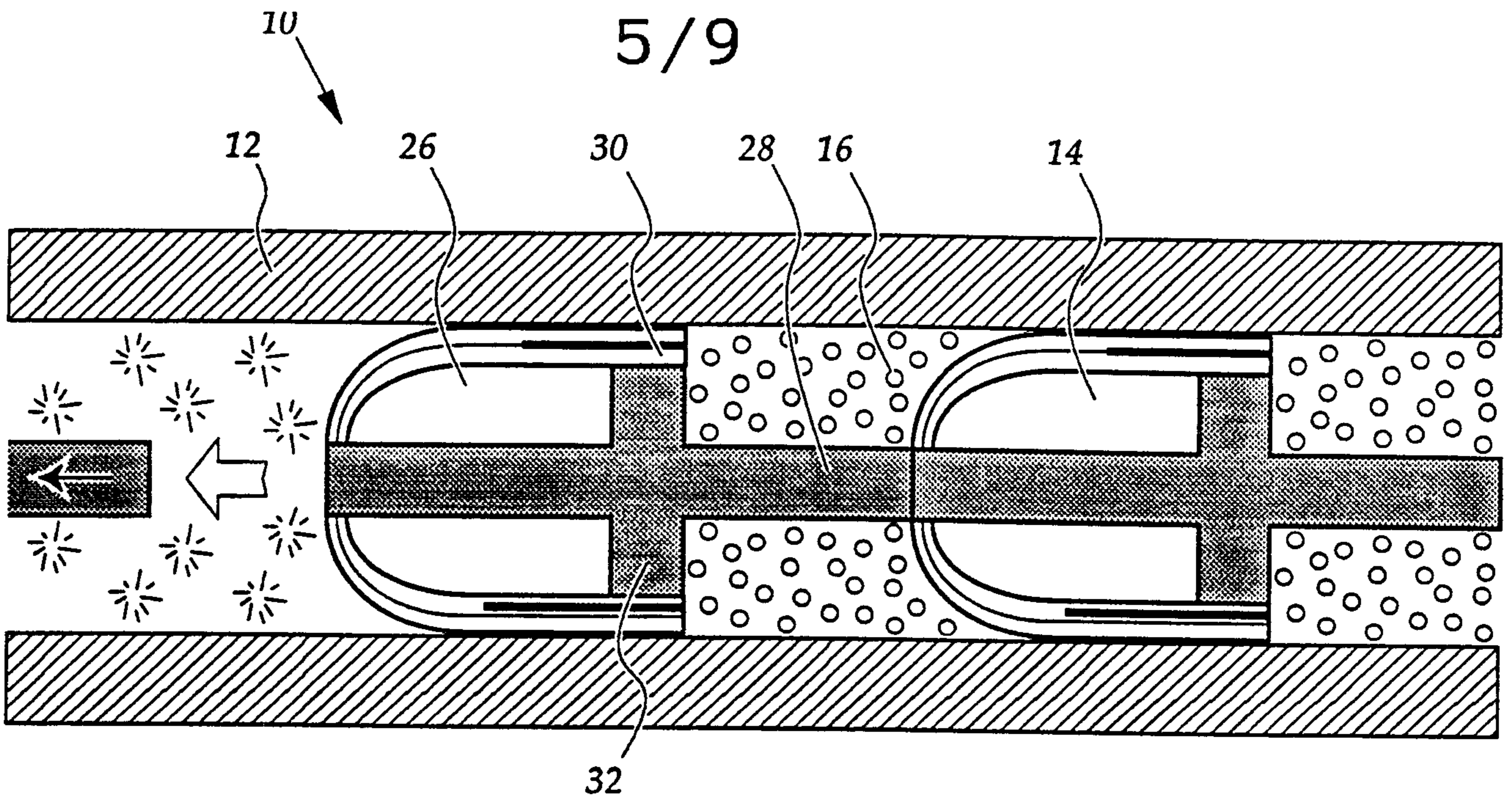

Figure 6.

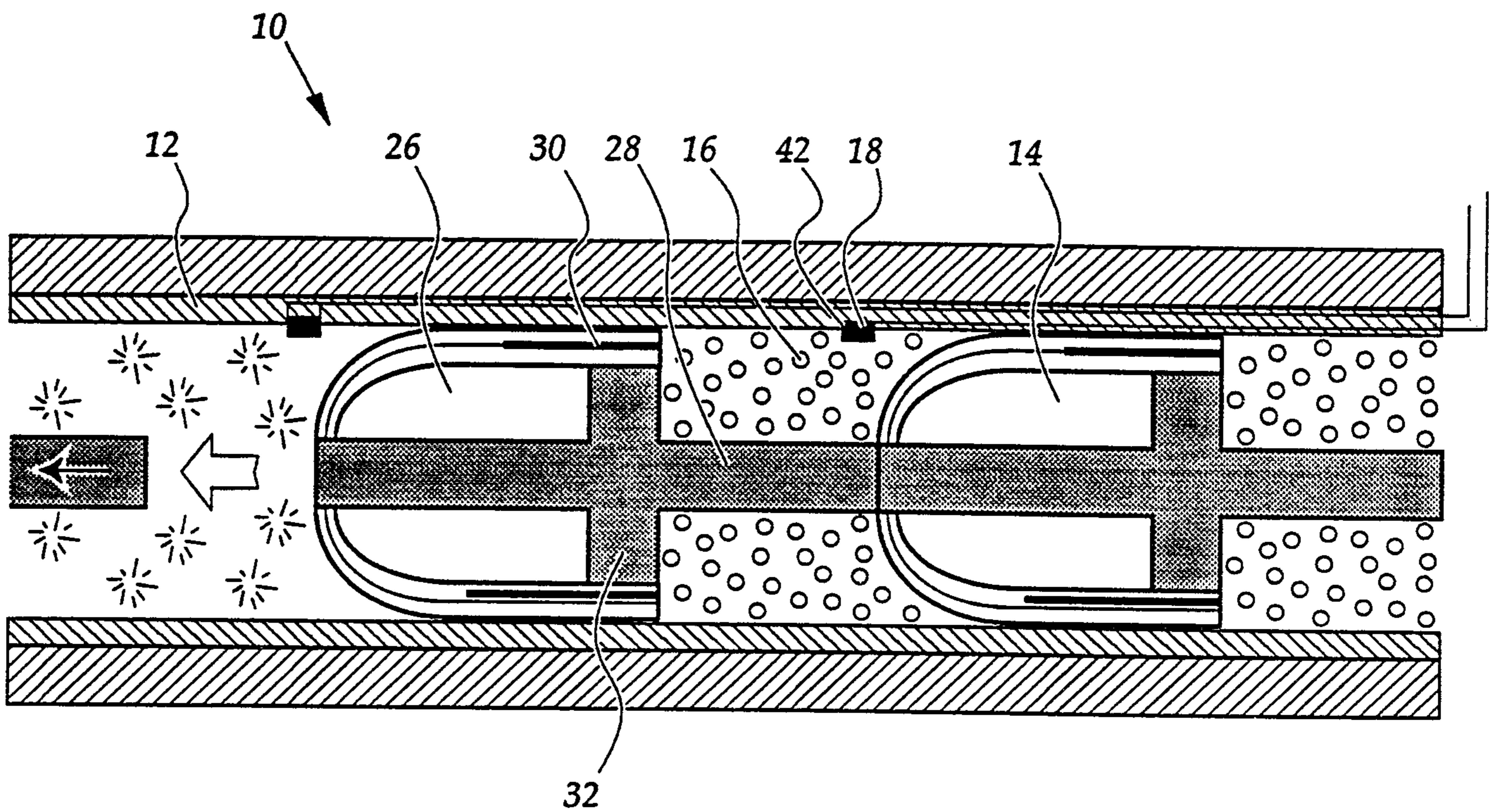

Figure 7.

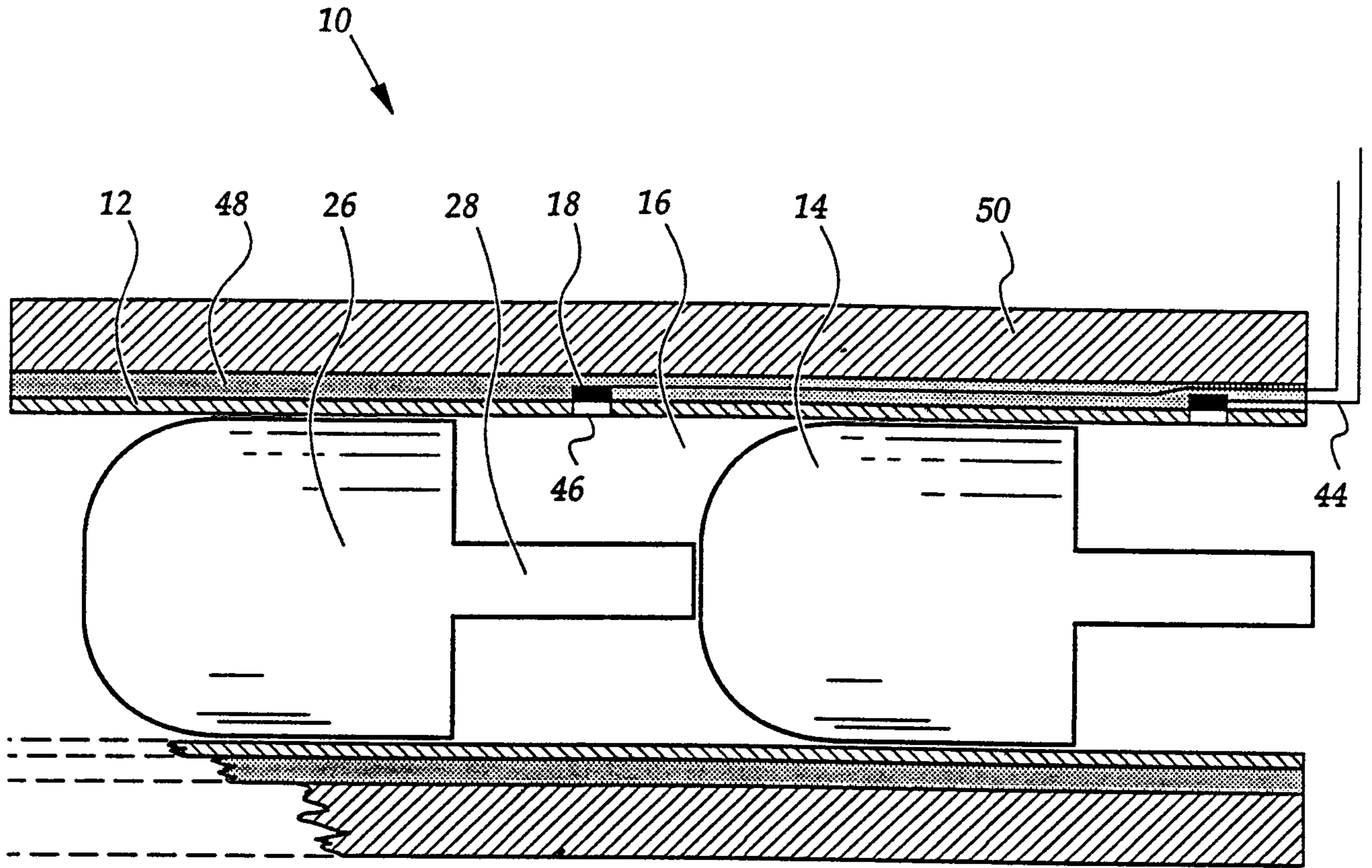

Figure 8.

7/9

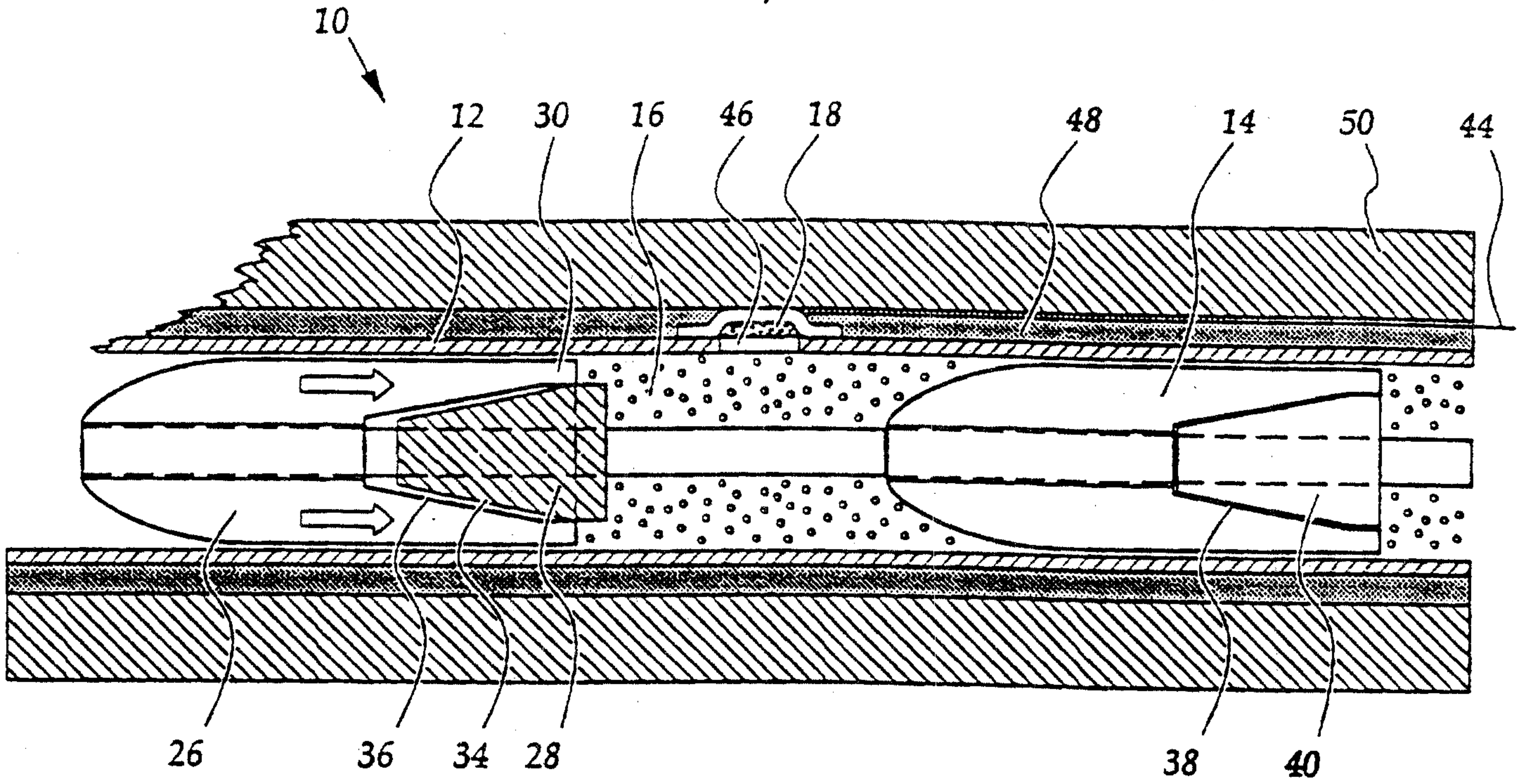

Figure 9.

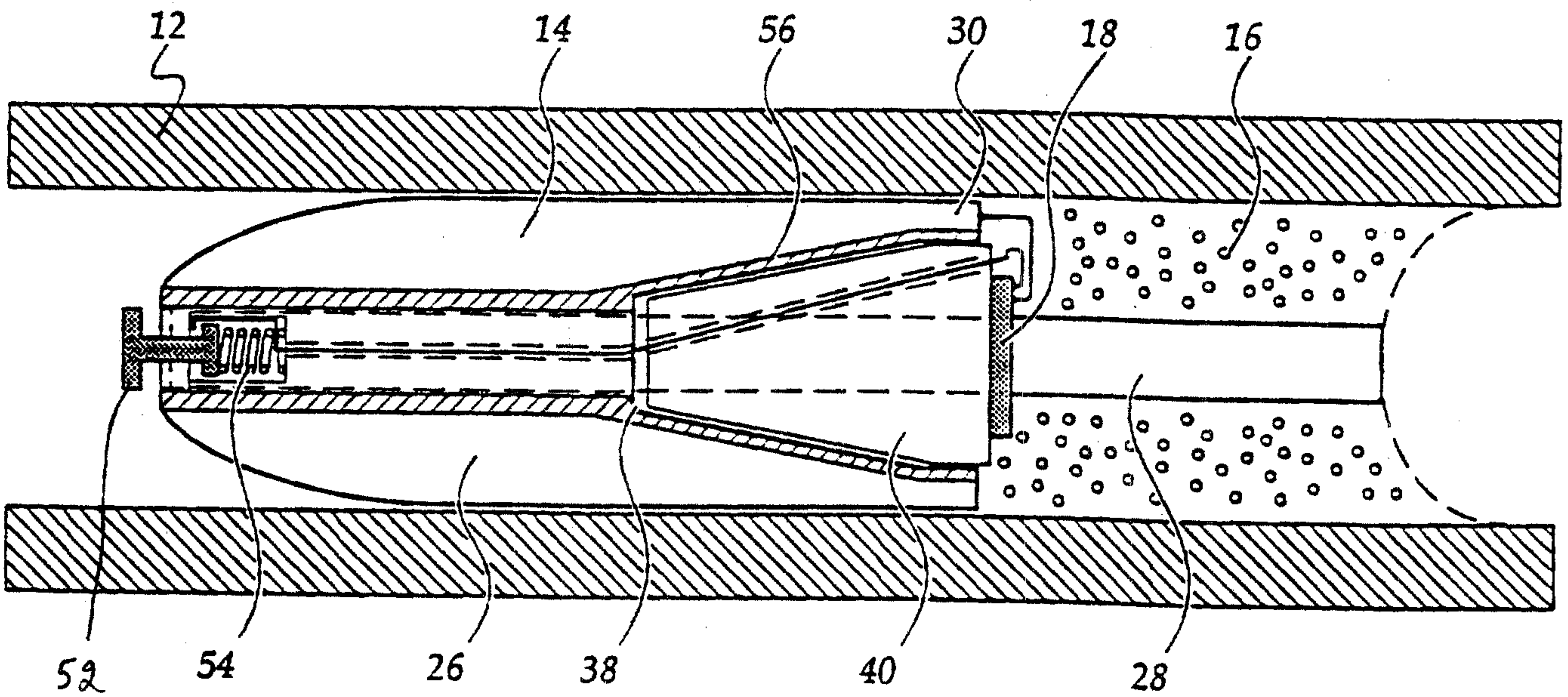

Figure 10.

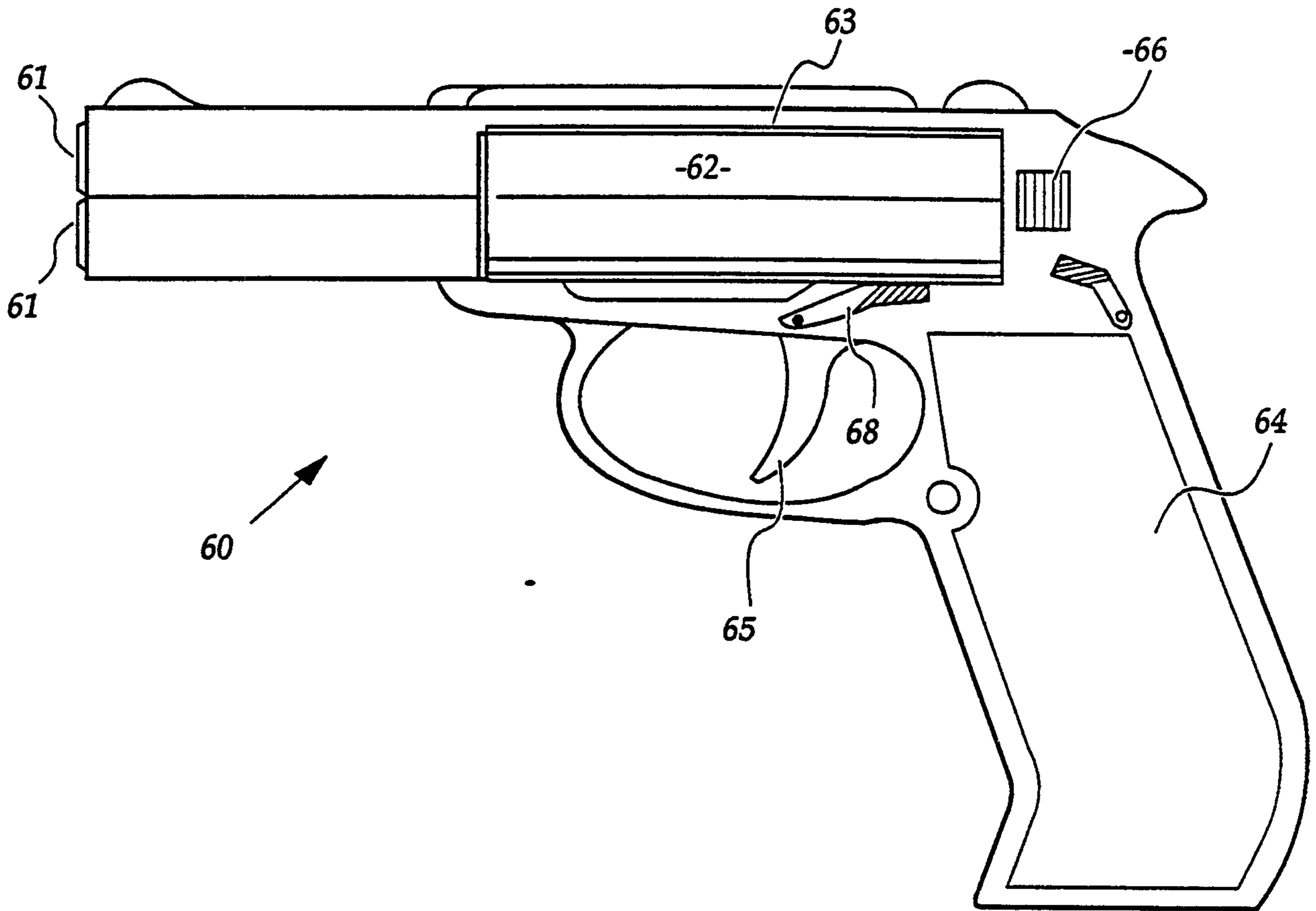

Figure 11.

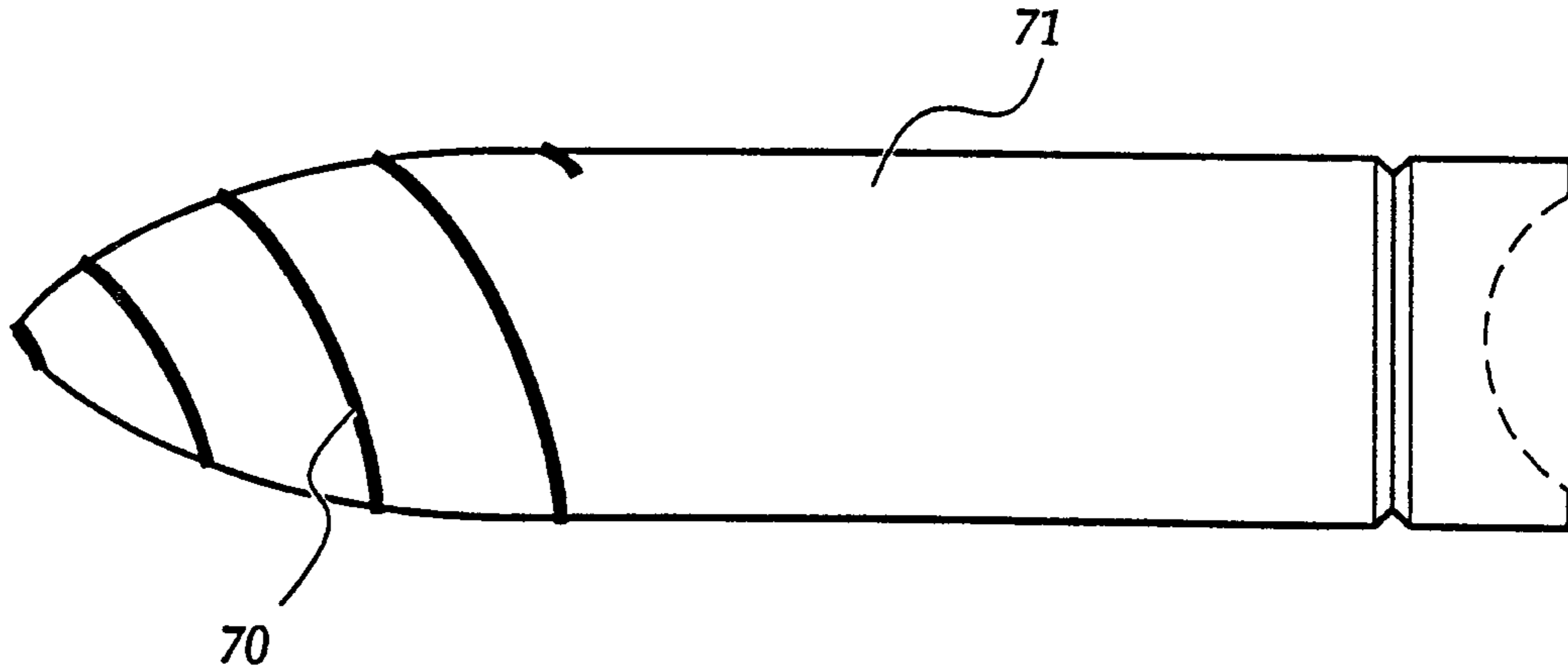

Figure 12.

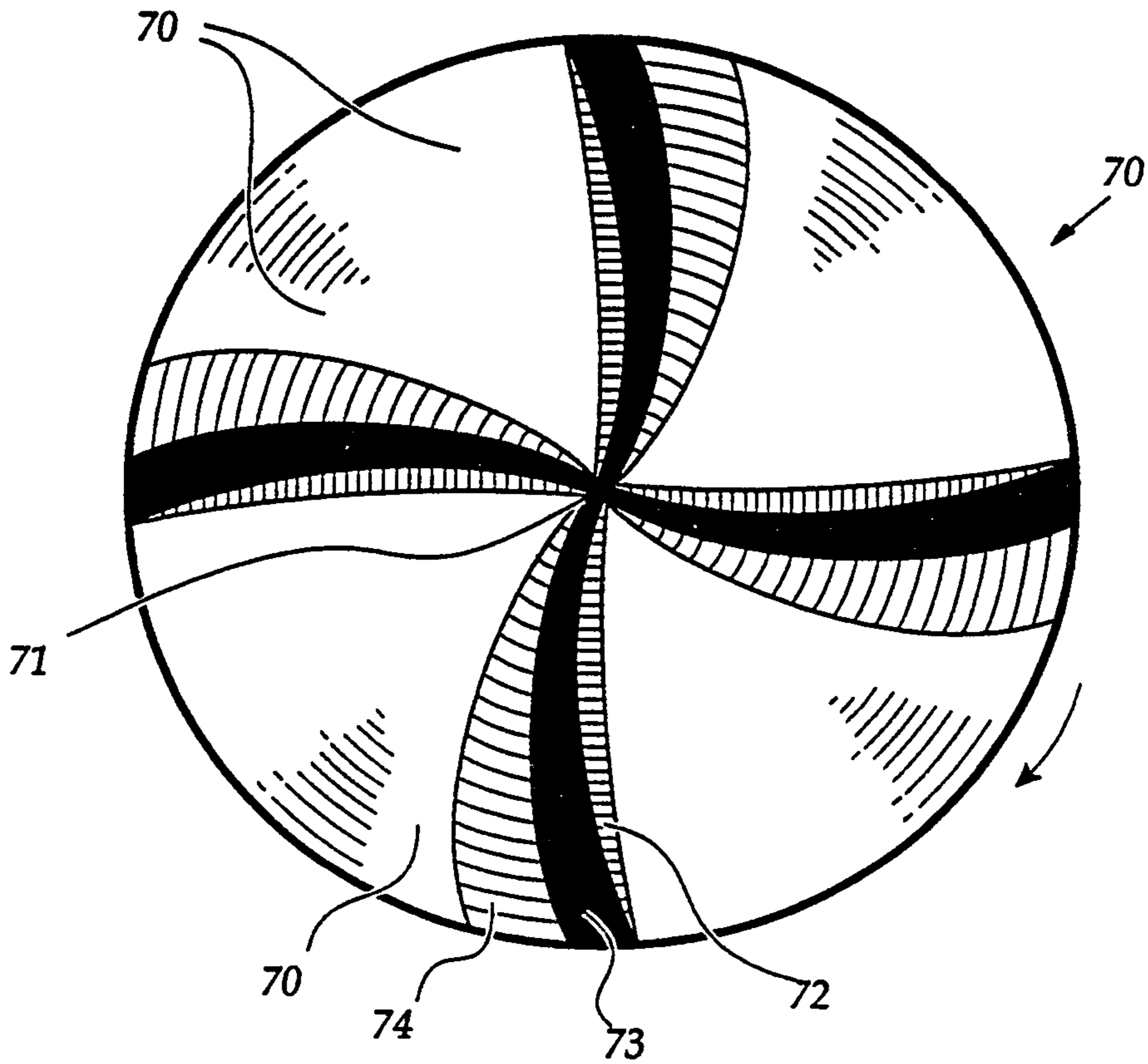

Figure 13.

