

May 24, 1927.

P. J. DARLINGTON

1,629,480

MICROMETER CALIPER

Filed Sept. 28, 1925

Fig. 1.

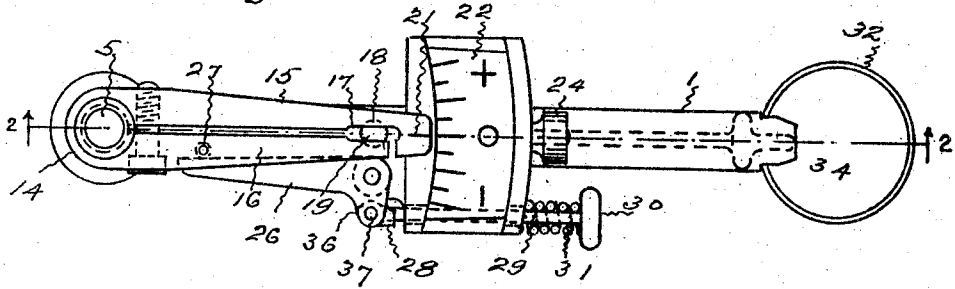
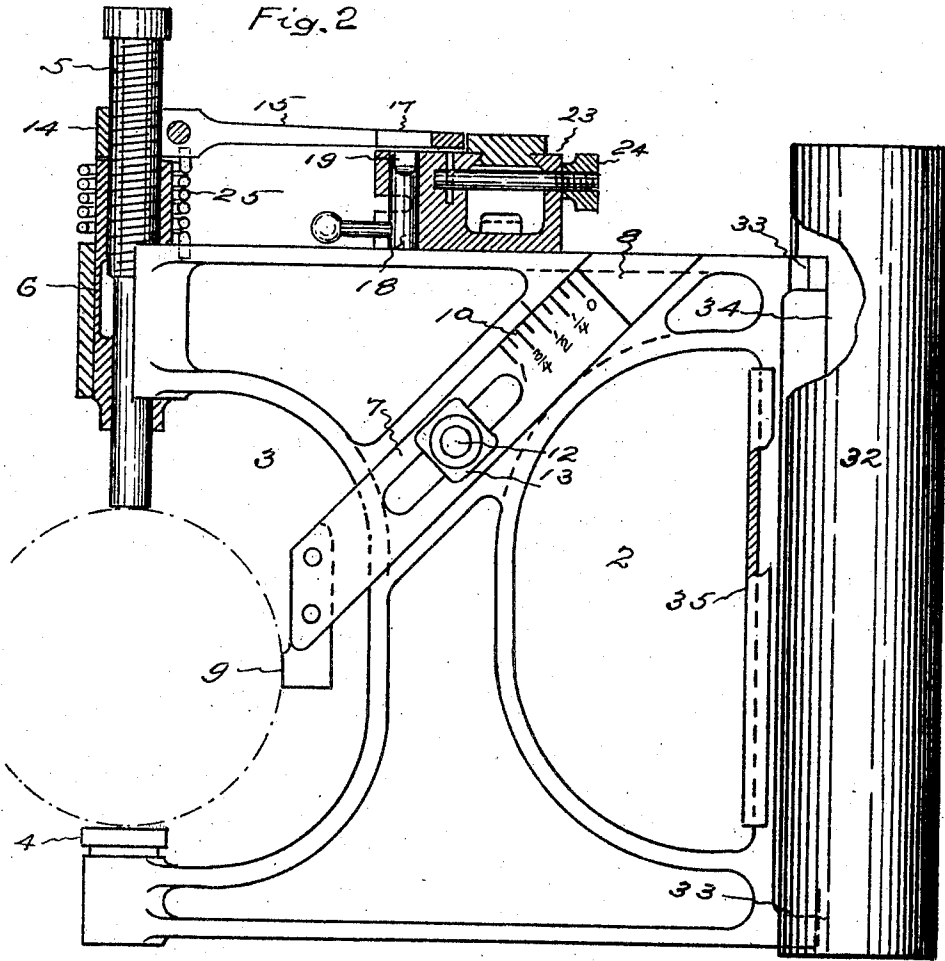

Fig. 2



INVENTOR

Philip J. Darlington

UNITED STATES PATENT OFFICE.

PHILIP J. DARLINGTON, OF BROOKLINE, MASSACHUSETTS.

MICROMETER CALIPER.

Application filed September 28, 1925. Serial No. 59,023.

This invention relates to micrometer calipers, and especially to that type used in measuring diameters of cylinders by comparison with standards to which the instrument is set.

The object of the present invention is to provide an instrument of this character which is relatively cheap to manufacture, which is simple to manipulate, and has increased speed, accuracy, adaptability, and capacity over those of similar character which are in common use.

The device illustrated and described herein broadly comprises a frame supporting a fixed anvil and a spring driven micrometer screw carrying an index arm registering with a graduated adjustable dial segment, and preferably limited to less than one revolution, with means for disconnecting the arm and holding it at zero position while making coarse adjustment of the screw, means for fine adjustment of the index segment over a small angular range, a heat insulated hand grip on the frame, a thumb attachment for opening the caliper with the hand holding it, and an adjustable stop for centering the instrument on the cylinder to be measured.

In the accompanying drawings Fig. 1 shows a plan of an instrument that embodies the invention. Fig. 2 shows a vertical view, partly in section on the plane indicated by the dash and dot line 2—2 on Fig. 1.

The device illustrated has a frame 1 with a D-shaped rear hand opening 2 and a C-shaped front work opening 3 between the arms which support a fixed anvil 4 and a micrometer screw 5 threaded into a removable sleeve 6.

The center stop 7 is slidable in a channel 8 formed in the frame, at 45° angle to the axis of the screw. The lower end of the stop has a contact surface 9 which vertically is midway between the end faces of the screw and anvil, and horizontally is at one side of the center line passing between the end faces of the screw and anvil one-half of the length of that center line. This stop serves to center a cylinder of any diameter when adjusted according to graduations 10 and clamped in position by a bolt 12 and clamp nut 13.

An index member is mounted upon the micrometer screw. This member has a flexible hub 14 threaded on the screw and two arms 15 and 16 that extend from the hub

with a space 17 between them. The hub is sprung upon and frictionally grips the screw. A bolt 18 with its upper end shaped to form a cam 19 is slidable and rotatable in its seat on the frame so that the cam may be entered into and turned in the space 17 between the arms and thereby spread and hold them in position while the screw is being turned, thus permitting adjustment of the screw and retaining the index member in zero position. The arm 15 carries an index line 21 that cooperates with a graduated segment 22 which is angularly adjustable in its supporting stand 23 and is clamped in adjusted position by a bolt and nut 24.

A spring 25 with one end connected with the frame and the other end connected with the index member is tensioned so as to rotate the micrometer screw onto the object being measured. A bell-crank lever 26, pivoted on the stand 23, engages a pin 27 on the index member and has a heel 28 which limits its movement and that of the index member. A rod 29 slidable in the stand 23 has an eye 36 engaged with a pin 37 on the lever 26. On this rod is a button 30 conveniently located for opening the instrument with the thumb of the hand holding it. A spring 31 between the button and stand normally withdraws the rod and holds the end of the lever away from the index member.

A tubular hand grip member 32 is attached to corner extensions 33 of the frame, leaving an air space 34 between the grip member and the frame. A heat insulating grip member 35 may be secured to the frame in the hand opening 2.

When the device is to be used, the indicating member is moved to zero position and there opened and held by means of the bolt 18. The center stop is set for the diameter to be produced, and the micrometer screw is turned by the thumb piece 20 onto the standard, after which the bolt 18 is withdrawn and the indicating member released. The button 30 on the rod 29 is then pressed inward. This causes the lever 26 to engage the pin 27 and so turn the indicating member that the micrometer screw is turned outward away from the standard. The button is released and the micrometer screw under the tension of the spring 25 is allowed to turn against the standard. The position of the index line 21 on the indicator is noted and the scale 22 is adjusted, if necessary,

so that the index line and zero on the scale will register.

The grip member 32 receives the heat from the palm of the hand and is effectively insulated from the frame by the very small area of the contacts on the extension 33. The member 35 insulates the frame from the heat of the thumb and finger of the user.

The invention claimed is:—

1. A micrometer caliper comprising a threaded adjustable measuring member, an indicating member clamped thereon and normally rotatable therewith, and means adapted to engage said member and coincidentally loosen said indicating member from the measuring member and hold it stationary during the adjustment of the measuring member.

2. A micrometer caliper comprising a frame with a graduated scale, a micrometer screw, an index arm threaded on and normally rotatable with said screw, and means movably mounted on the frame for simultaneously releasing said arm from the screw and holding it in zero position with relation to the scale while adjusting said screw.

3. A micrometer caliper comprising a frame with a graduated scale, a screw having a micrometer thread adjustable in said frame, an indicating arm frictionally engaged and normally rotatable with said screw, and a bolt adapted to be moved into engagement with the arm for simultaneously releasing the friction of said arm on the screw and holding it stationary while adjusting the screw.

4. A micrometer caliper comprising a screw having a micrometer thread, a threaded stationary member engaged by the screw, an indicating arm frictionally connected to and normally rotatable with said screw, a graduated scale adjustable concentrically with the axis of said screw, and means adapted to be engaged with the arm for simultaneously relieving the frictional connection of said arm from the screw and holding it stationary while adjusting the screw.

5. A micrometer caliper comprising a frame supporting an anvil and a micrometer screw opposite said anvil between which the object to be measured is inserted, a graduated center stop adjustable on the frame toward and from the center line between said anvil and screw, an index arm threaded upon and fastened to the screw, a graduated scale with which the index arm registers, adjustably mounted on the frame, and means for temporarily holding said index arm registered with said scale while the screw is being adjusted.

6. A micrometer caliper comprising a frame supporting an anvil and a micrometer screw opposite said anvil between which the object to be measured is inserted, a center

stop adjustable at an angle of 45° on the frame toward and from the center line between said anvil and screw, said stop and frame having co-acting index and scale graduations, an index arm adjustably attached to the screw, and an adjustable scale with which the index arm registers.

7. A micrometer caliper comprising a frame supporting an anvil and a micrometer screw opposite said anvil between which the object to be measured is inserted, a center stop adjustable at an angle of 45° on the frame toward and from the center line between said anvil and screw, an index arm normally rotatable with said screw, means for releasing said arm from the screw and retaining it stationary, and a graduated scale with which the index arm registers.

8. A micrometer caliper comprising a frame supporting an anvil and a micrometer screw opposite said anvil between which the object to be measured is inserted, a center stop adjustable at an angle of 45° on the frame toward and from the center line between said anvil and screw, an index arm carried by the screw, a graduated scale with which the index arm registers, a spring for rotating the screw in one direction, and means, operative by the thumb of the holder, for rotating the screw in the opposite direction.

9. A micrometer caliper comprising a frame supporting an anvil and a micrometer screw opposite said anvil between which the object to be measured is inserted, a center stop adjustable at an angle of 45° on the frame toward and from the center line between said anvil and screw, an index arm carried by the screw, a graduated scale with which the index arm registers, a spring for rotating the screw in one direction, a lever for rotating the screw in the opposite direction, and a push rod for actuating said lever.

10. In a micrometer caliper a frame, an index arm, a micrometer spindle threaded into said frame and said arm, means for holding said arm stationary relative to said frame while adjusting said spindle through both, and means for frictionally clamping said arm to said spindle in adjusted position thereon.

11. A micrometer caliper comprising a frame, a micrometer spindle adjustably threaded therein, an index arm comprising a split hub frictionally mounted on and normally rotatable with said spindle and extensions from said hub, and a cam arranged to be operated between said extensions to open said hub and release it from frictional engagement with said spindle during adjustment of said spindle in said frame.

12. A micrometer caliper comprising a frame supporting an anvil, a micrometer

screw opposite the anvil and a center stop adjustable toward and from the center line between said anvil and screw, an index arm carried by the screw, a graduated scale with which the index arm registers, a spring for rotating the screw in one direction, and means operative by the thumb of the holder for rotating the screw in the opposite direction.

5 13. A micrometer caliper comprising a frame supporting an anvil and a micrometer screw opposite said anvil between which the object to be measured is inserted, an index arm threaded upon and rotatable with the screw, a graduated scale with which the index arm registers, a spring for rotating the screw in one direction, a lever for rotating the screw in the opposite direction, and means for actuating said lever.

10 PHILIP J. DARLINGTON.