



US009027628B2

(12) **United States Patent**
Watkins et al.

(10) **Patent No.:** **US 9,027,628 B2**
(45) **Date of Patent:** **May 12, 2015**

(54) **INTERIOR SHUTTER-BLIND FOR WINDOWS WITH STACKABLE LOUVERS**

(71) Applicant: **Comfortex Corporation**, Maplewood, NY (US)

(72) Inventors: **Richard Watkins**, Lake Luzerne, NY (US); **Jason Vandervoort**, Averill Park, NY (US); **John Corey**, Melrose, NY (US); **Mark Kitterman**, Gilbert, AZ (US); **Thomas Marusak**, Loudonville, NY (US)

(73) Assignee: **Comfortex Corporation**, Maplewood, NY (US)

(*) Notice: Subject to any disclaimer, the term of this patent is extended or adjusted under 35 U.S.C. 154(b) by 0 days.

(21) Appl. No.: **13/676,377**

(22) Filed: **Nov. 14, 2012**

(65) **Prior Publication Data**

US 2014/0033610 A1 Feb. 6, 2014

Related U.S. Application Data

(63) Continuation-in-part of application No. 13/460,326, filed on Apr. 30, 2012, which is a continuation of application No. 12/424,469, filed on Apr. 15, 2009, now Pat. No. 8,201,609.

(51) **Int. Cl.**

E06B 9/30 (2006.01)
E06B 7/086 (2006.01)

(Continued)

(52) **U.S. Cl.**

CPC . **E06B 7/086** (2013.01); **E06B 7/10** (2013.01); **F16H 21/44** (2013.01); **E06B 7/09** (2013.01); **E06B 7/096** (2013.01); **E06B 9/0638** (2013.01); **E06B 9/0676** (2013.01); **E06B 9/28** (2013.01)

(58) **Field of Classification Search**

CPC E06B 7/084; E06B 7/086; E06B 9/389; E06B 9/28; E04F 10/10; F24F 13/15; E05F 17/00

USPC 160/166.1, 174 R, 175, 176.1 R, 173 R, 160/178.1 R, 34, 167 R, 172 R, 168.1 R; 49/74.1, 82.1, 86.1, 90.1, 89.1

See application file for complete search history.

(56) **References Cited**

U.S. PATENT DOCUMENTS

1,708,636 A 4/1929 Shook
1,888,522 A 11/1932 Lawrence

(Continued)

FOREIGN PATENT DOCUMENTS

EP 2351902 A2 * 8/2011

OTHER PUBLICATIONS

Andy Lin, "Paper Clip Your Blinds Open for Better Lighting (Without Sacrificing Privacy)", Feb. 10, 2011; [retrieved from the internet, Mar. 3, 2014: <http://lifehacker.com/5757330/paper-clip-your-blinds-for-increased-light-without-sacrificing-privacy>.

(Continued)

Primary Examiner — Katherine Mitchell

Assistant Examiner — Johnnie A Shablack

(74) *Attorney, Agent, or Firm* — Schmeiser, Olsen & Watts LLP

(57) **ABSTRACT**

A shutter-blind system for windows is provided. The system includes a frame and a plurality of rotatable parallel louvers coupled within the frame. Each louver of the plurality of louvers is operatively coupled to adjacent louvers with a collapsible linkage. The system may further comprise a biasing member coupled to a first louver located at a first end of the plurality of louvers and a resisting member coupled to a second louver located at a second end of the plurality of louvers. The biasing member pulls against the resisting member to maintain tension in the collapsible linkage. According to certain embodiments, the frame elements are coupled within a window opening and trim elements are coupled to cover gaps between the frame elements and the window opening.

18 Claims, 13 Drawing Sheets

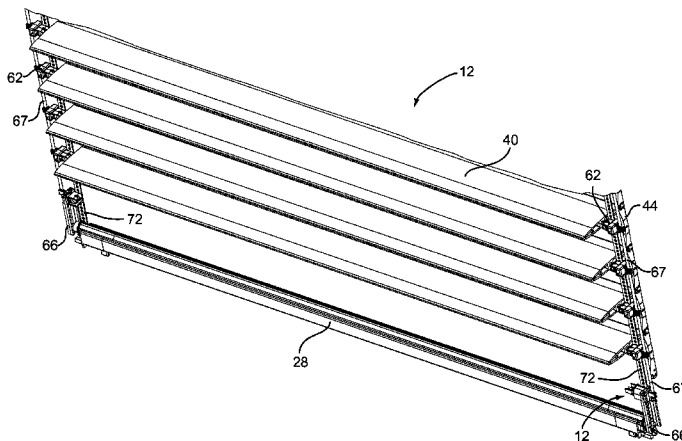

- (51) **Int. Cl.**
E06B 7/10 (2006.01)
F16H 21/44 (2006.01)
E06B 7/09 (2006.01)
E06B 7/096 (2006.01)
E06B 9/06 (2006.01)
E06B 9/28 (2006.01)

6,152,205	A	11/2000	Toti	
6,314,680	B1	11/2001	Buckwalter et al.	
6,499,255	B1	12/2002	Givoni	
6,536,162	B2	3/2003	LaMay	
6,675,534	B2	1/2004	Marocco	
6,701,669	B1*	3/2004	Yorgason	49/82.1
6,810,621	B1*	11/2004	Ricci	49/90.1
6,953,074	B2	10/2005	Cardinal	
7,331,370	B1	2/2008	Militello et al.	
7,353,636	B1	4/2008	Anderson et al.	
7,389,609	B2*	6/2008	Yorgason	49/82.1
7,866,737	B2*	1/2011	Browne et al.	296/193.1
7,896,056	B2	3/2011	Ben-David	
8,201,609	B1	6/2012	Kitterman	
8,281,518	B2*	10/2012	Marocco	49/82.1
8,302,653	B2*	11/2012	O'Hair	160/172 R
8,474,187	B2*	7/2013	Marocco	49/403
8,528,254	B1*	9/2013	Johnston	49/64
8,555,948	B2*	10/2013	Park	160/201
2001/0011581	A1	8/2001	Welfondr	
2004/0045220	A1	3/2004	Fraser et al.	
2005/0005523	A1*	1/2005	Johnston	49/74.1
2006/0225844	A1*	10/2006	Gittens et al.	160/115
2007/0187048	A1	8/2007	Hung	
2007/0193702	A1	8/2007	Hung	
2008/0099160	A1	5/2008	Chen	
2009/0223149	A1	9/2009	Zalesak	
2012/0097343	A1	4/2012	O'Hair	

(56) **References Cited**

U.S. PATENT DOCUMENTS

2,167,840	A	*	8/1939	Hepworth	160/172 R
2,708,295	A		5/1955	Johnson	
2,874,771	A		2/1959	Muhr	
3,001,250	A		9/1961	Kenny	
3,208,507	A		9/1965	Breen	
3,690,035	A		9/1972	Schindlauer	
3,744,544	A	*	7/1973	Wellensiek	160/169
4,155,395	A	*	5/1979	Frei	160/168.1 R
4,313,650	A		2/1982	Ward et al.	
4,449,563	A	*	5/1984	Toda et al.	160/184
4,616,688	A		10/1986	Agos	
4,763,713	A	*	8/1988	Kraus	160/172 R
4,850,138	A		7/1989	Watanabe et al.	
4,872,499	A		10/1989	Anderson	
5,392,561	A		2/1995	Henley, Sr.	
5,419,082	A		5/1995	Li	
5,469,658	A		11/1995	Digianni et al.	
5,474,117	A		12/1995	Henkenjohann	
5,595,231	A	*	1/1997	Marocco	160/168.1 R
5,813,447	A		9/1998	Lysyj	
6,041,547	A		3/2000	Marocco	
6,061,962	A	*	5/2000	Sosa	49/249

OTHER PUBLICATIONS

PCT International Search Report and Written Opinion for: PCT/US13/69925.

* cited by examiner

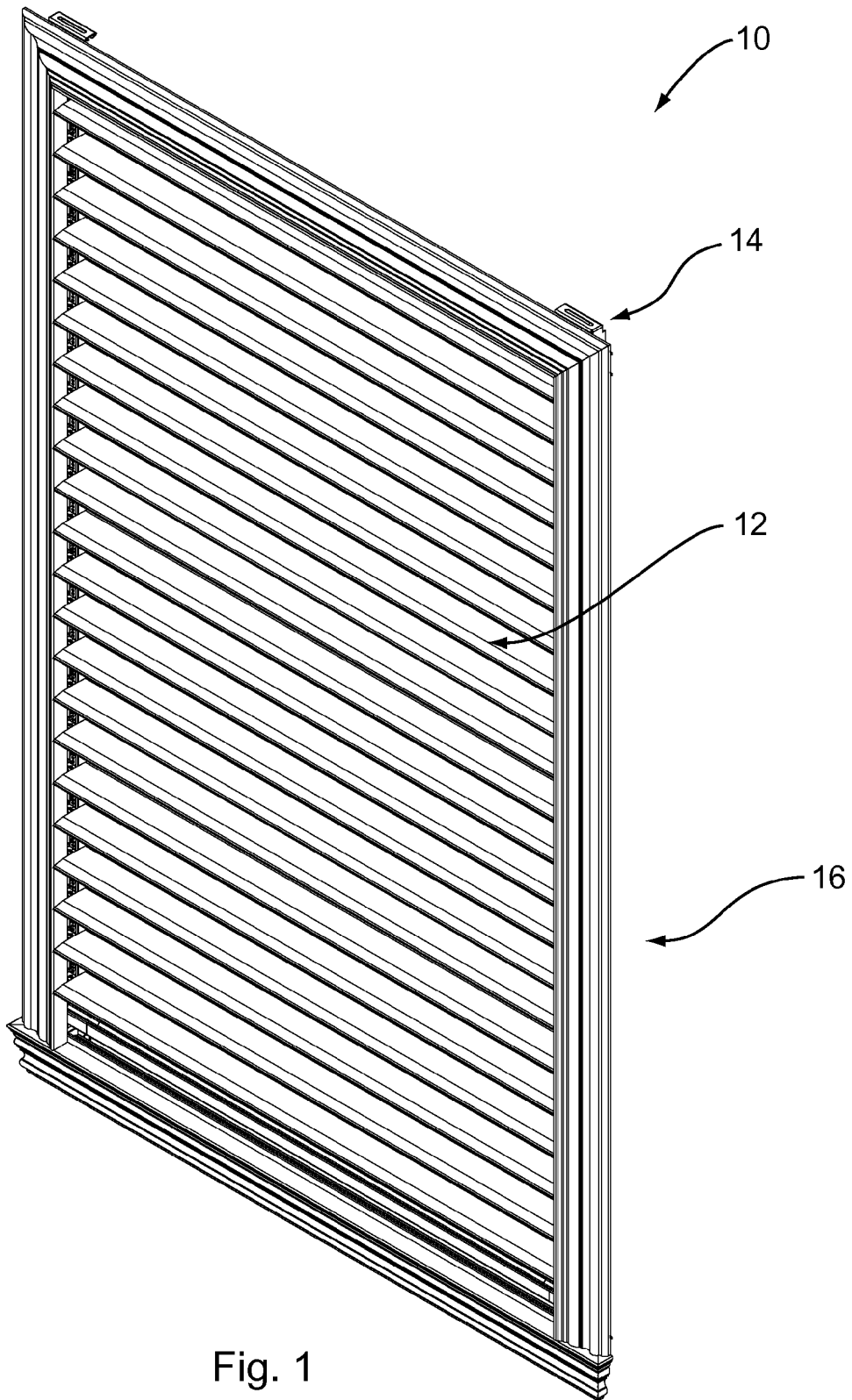

Fig. 1

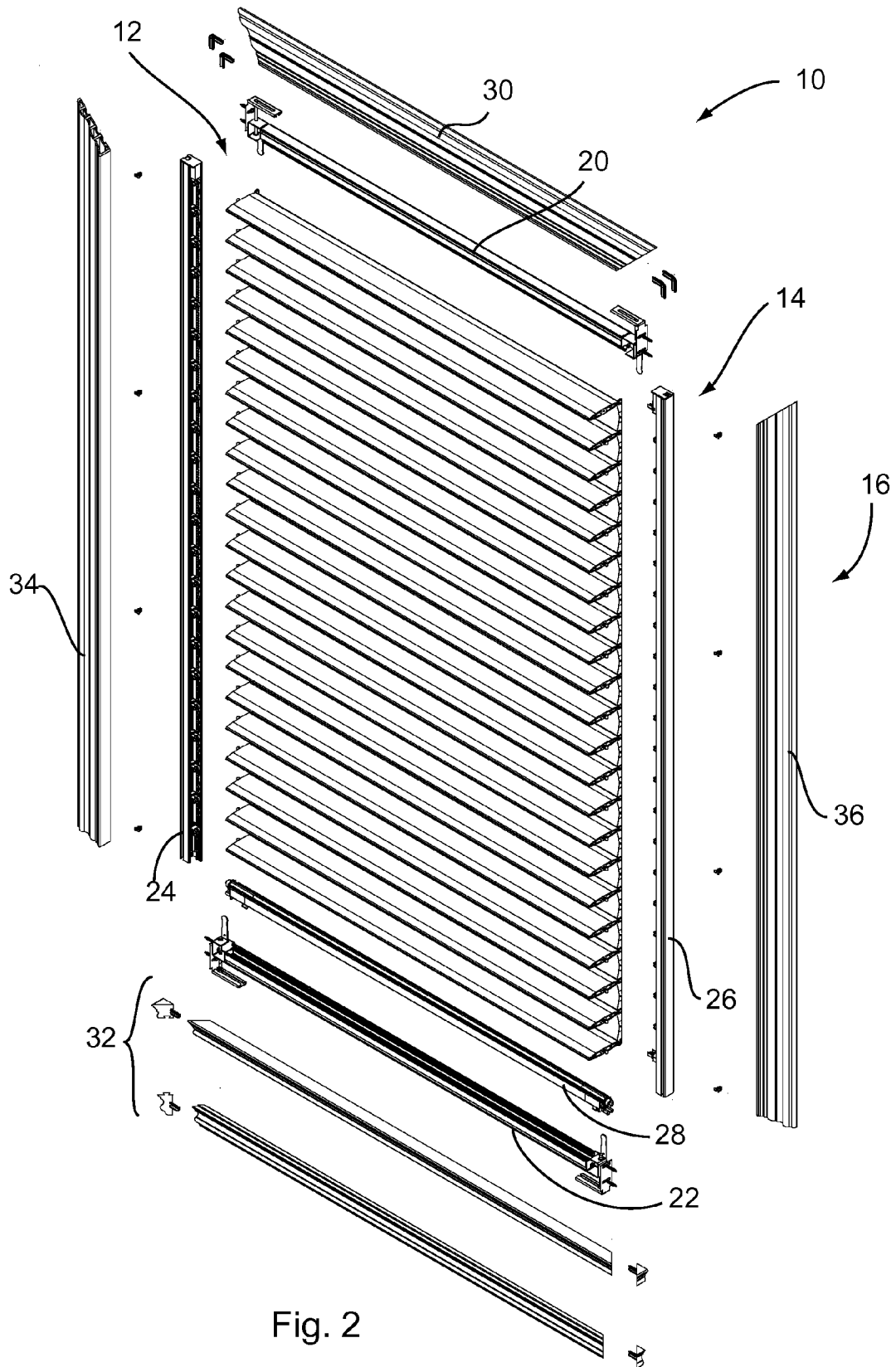

Fig. 2

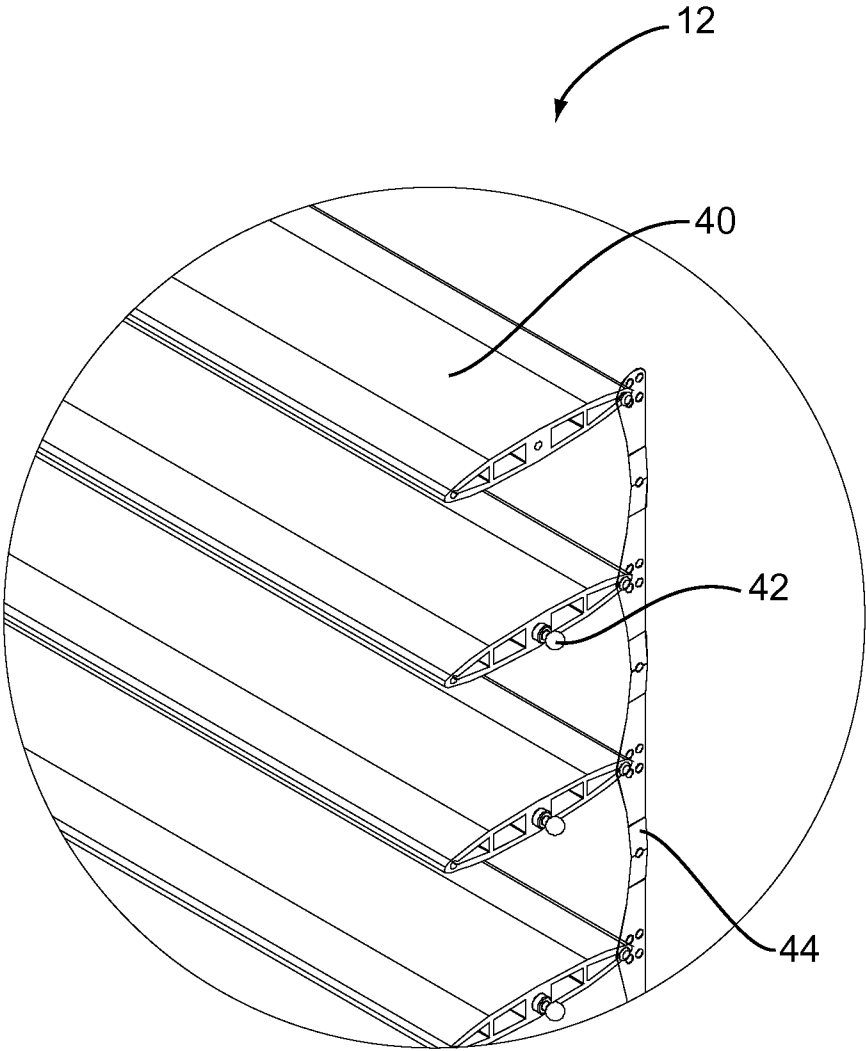

Fig. 3

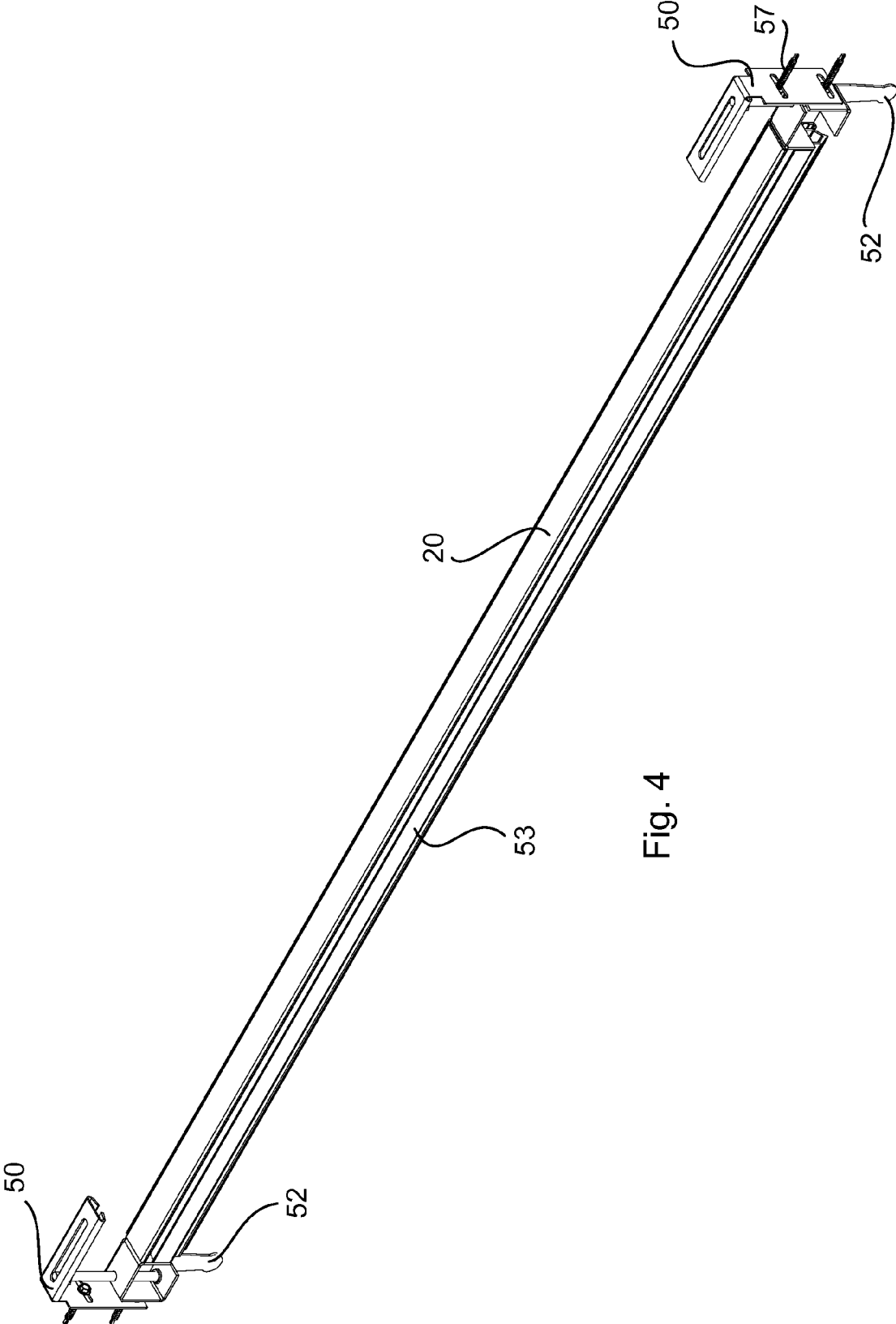

Fig. 4

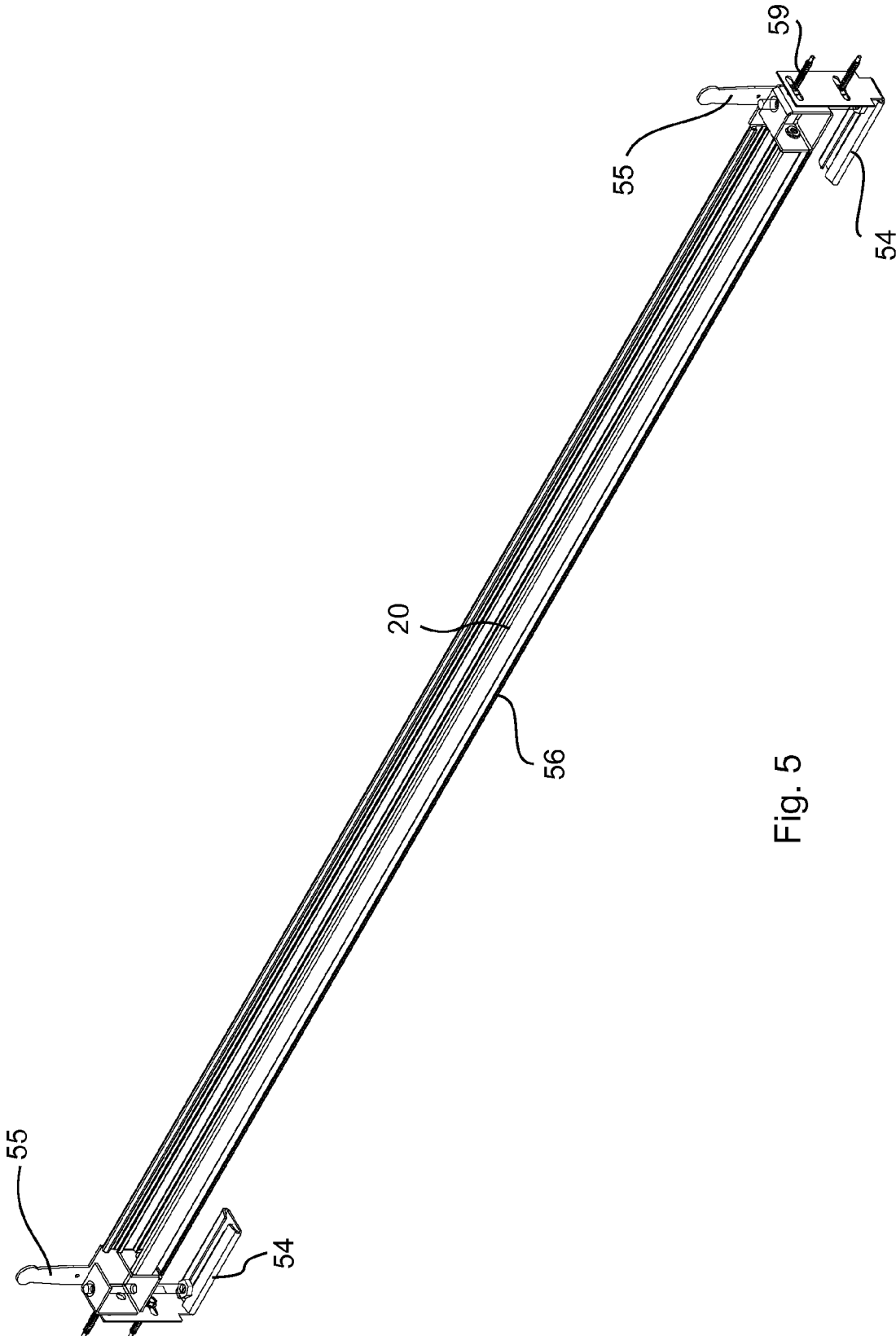

Fig. 5

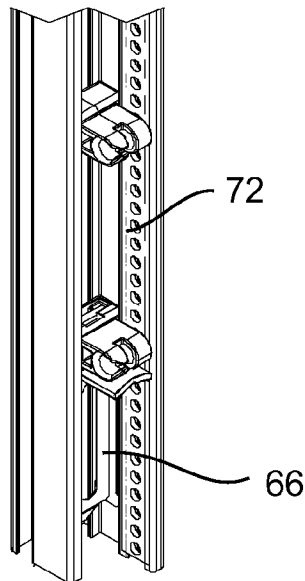
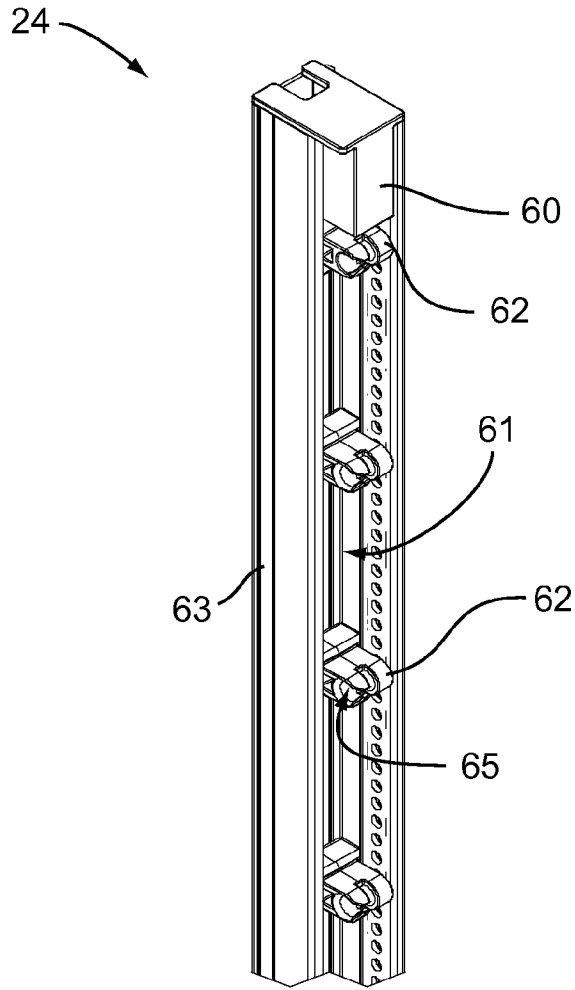

Fig. 6

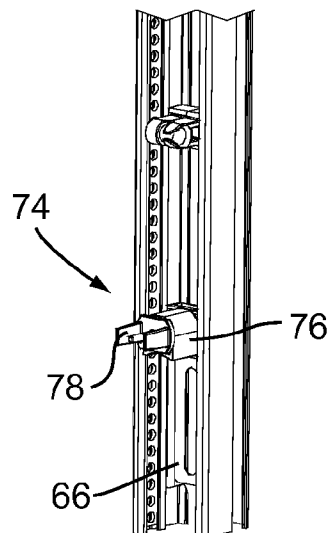
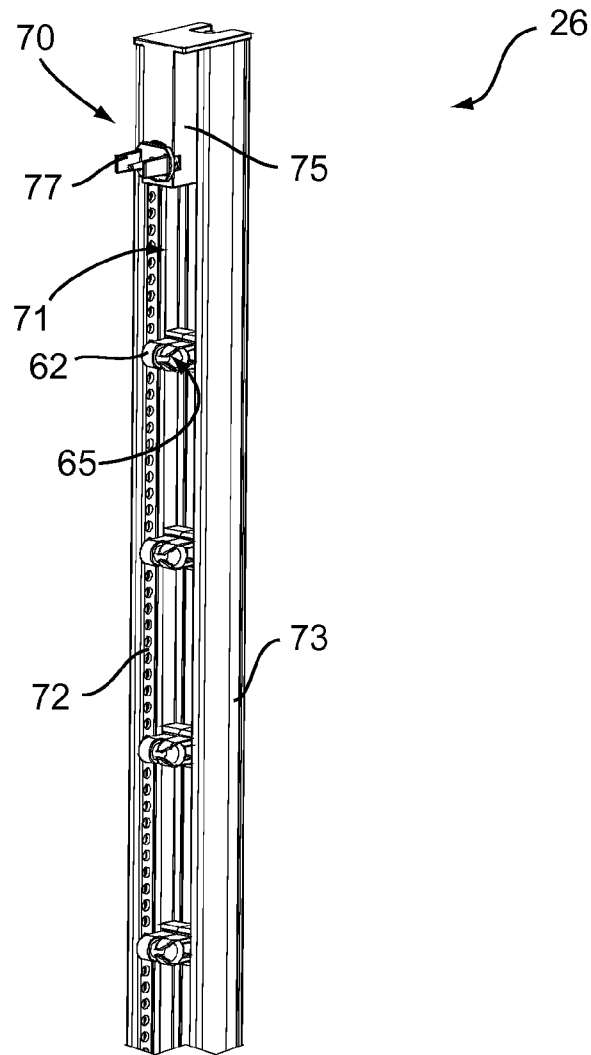

Fig. 7

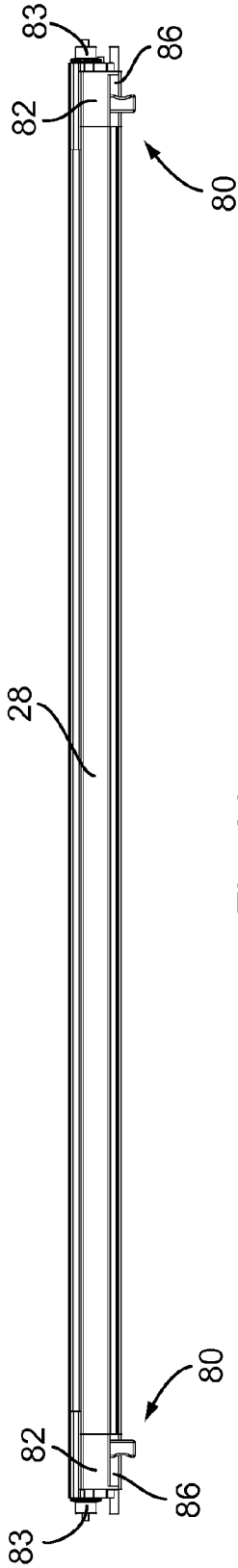

Fig. 8A

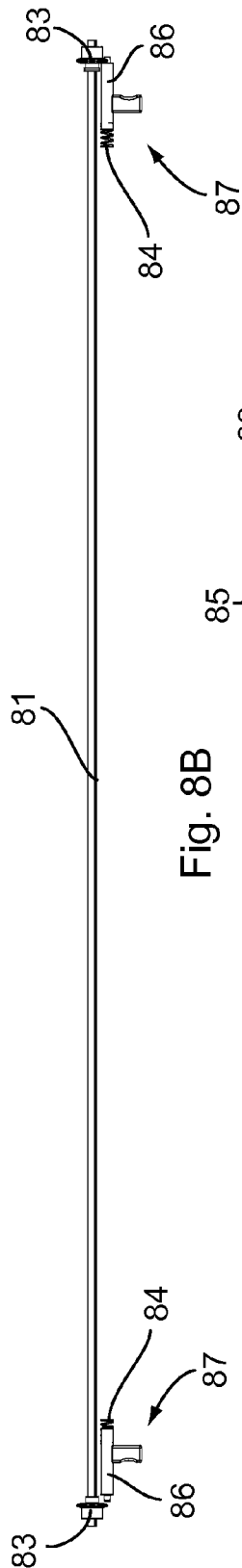

Fig. 8B

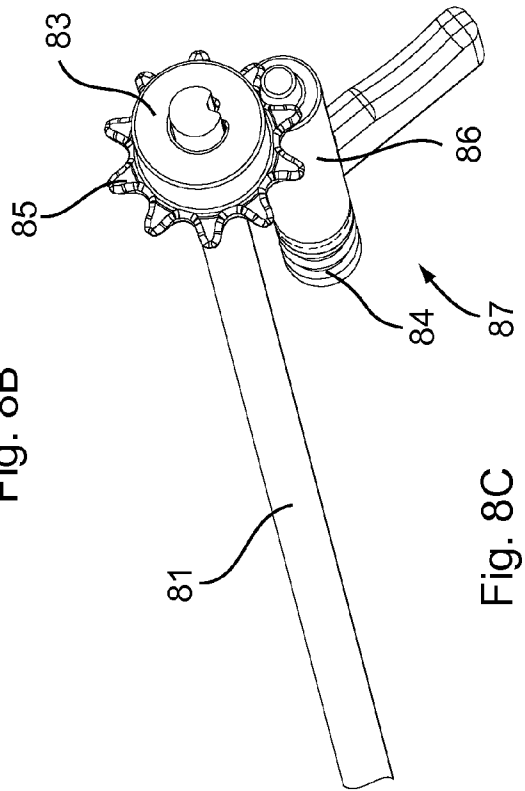

Fig. 8C

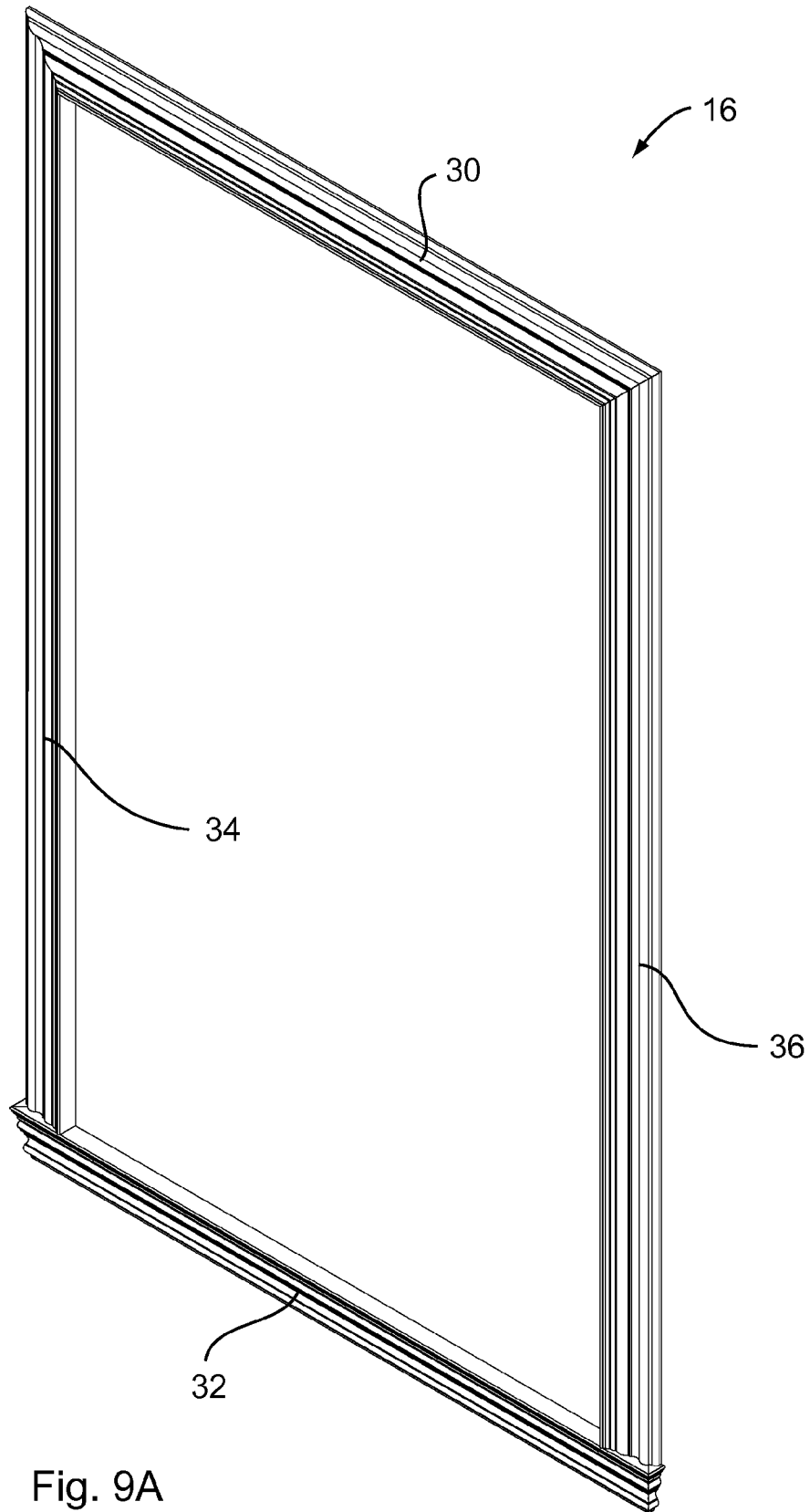

Fig. 9A

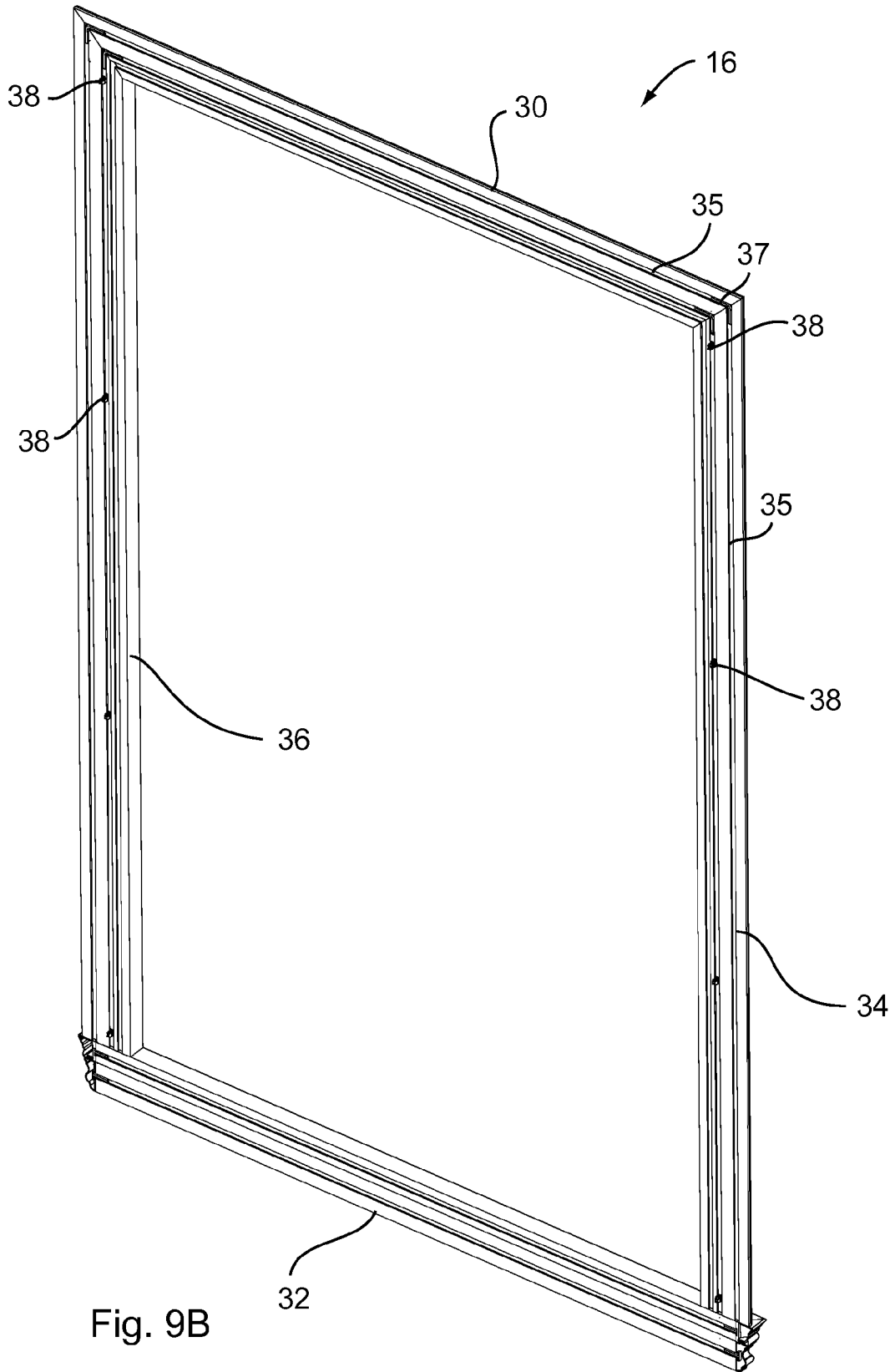

Fig. 9B

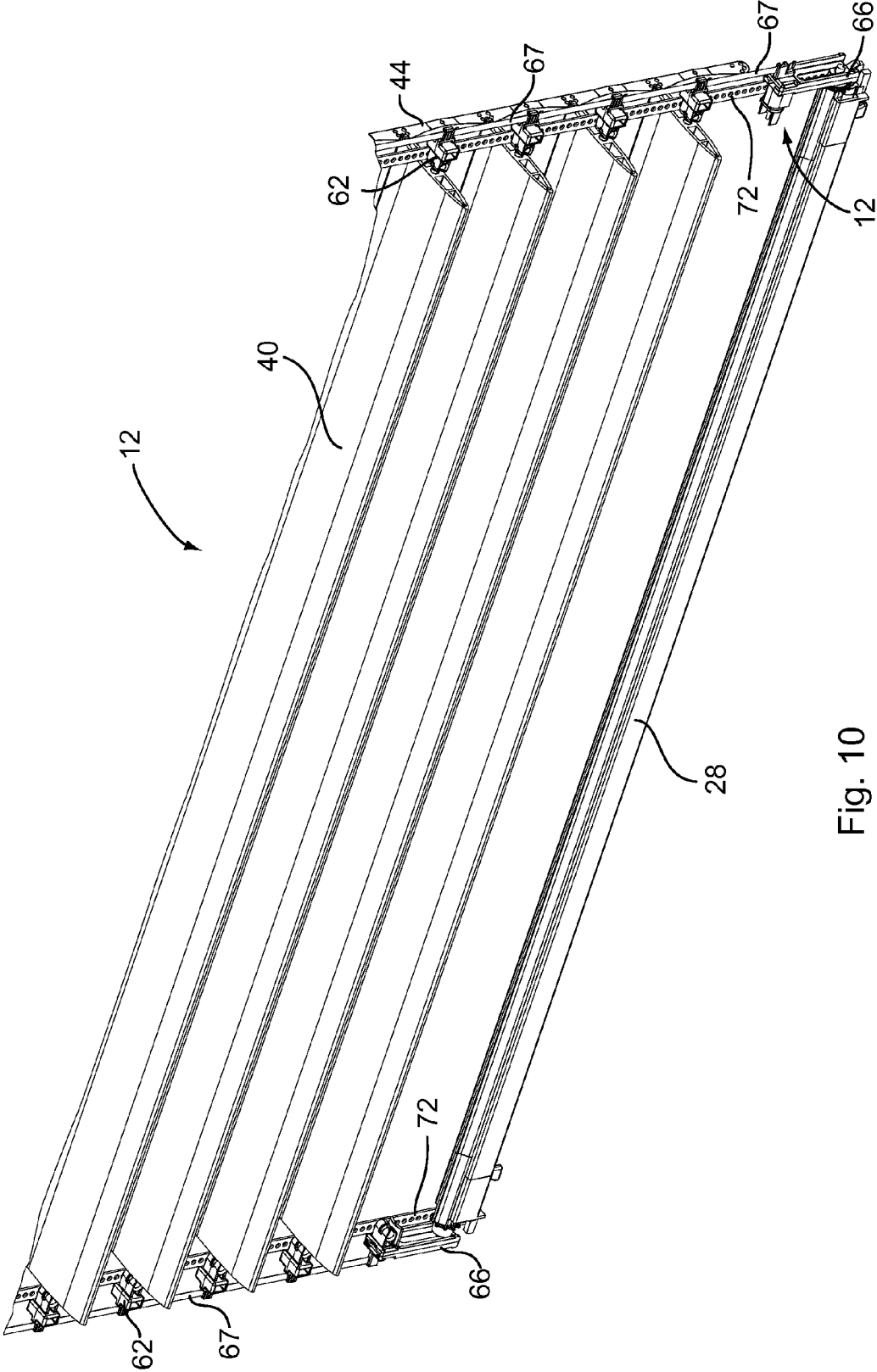

Fig. 10

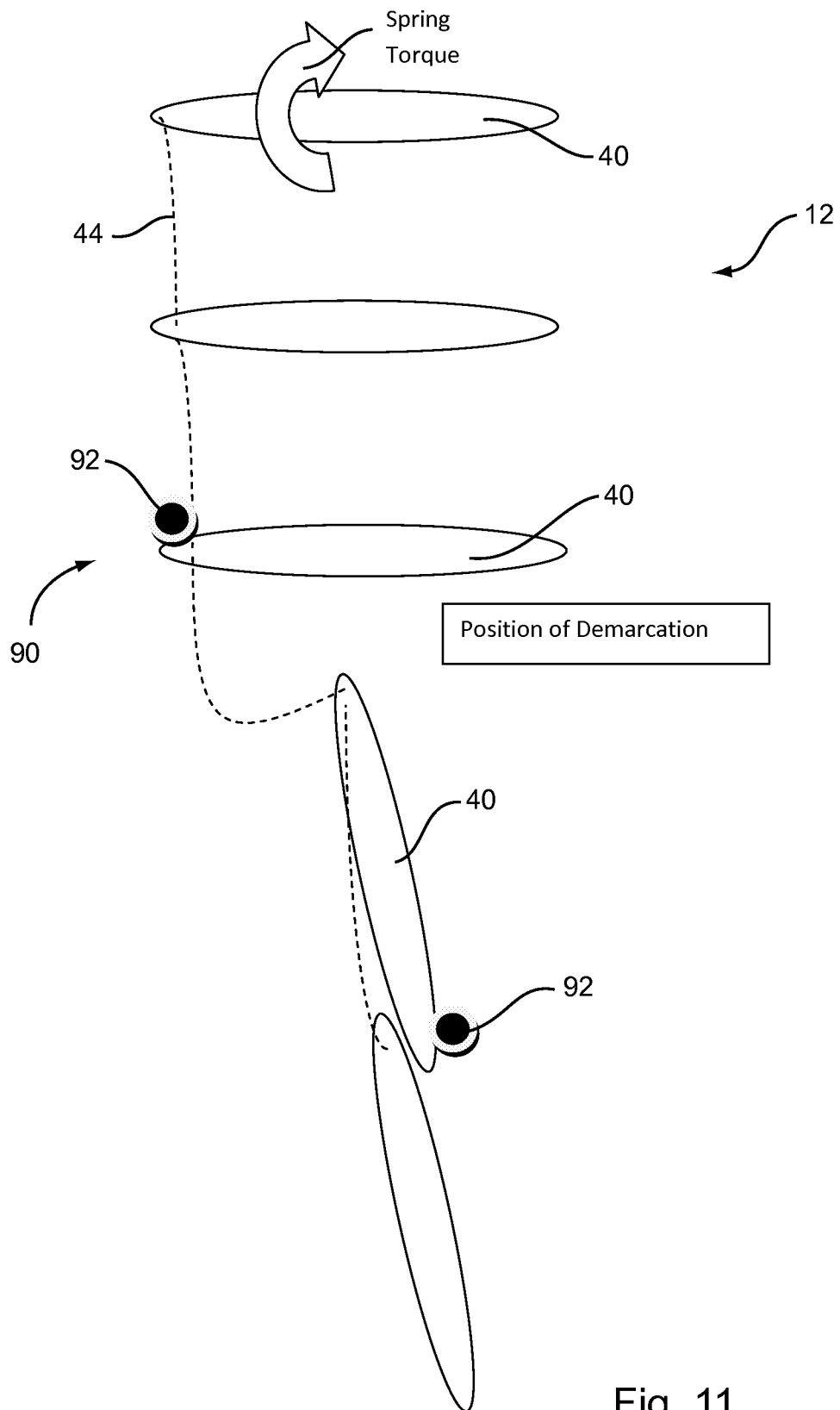

Fig. 11

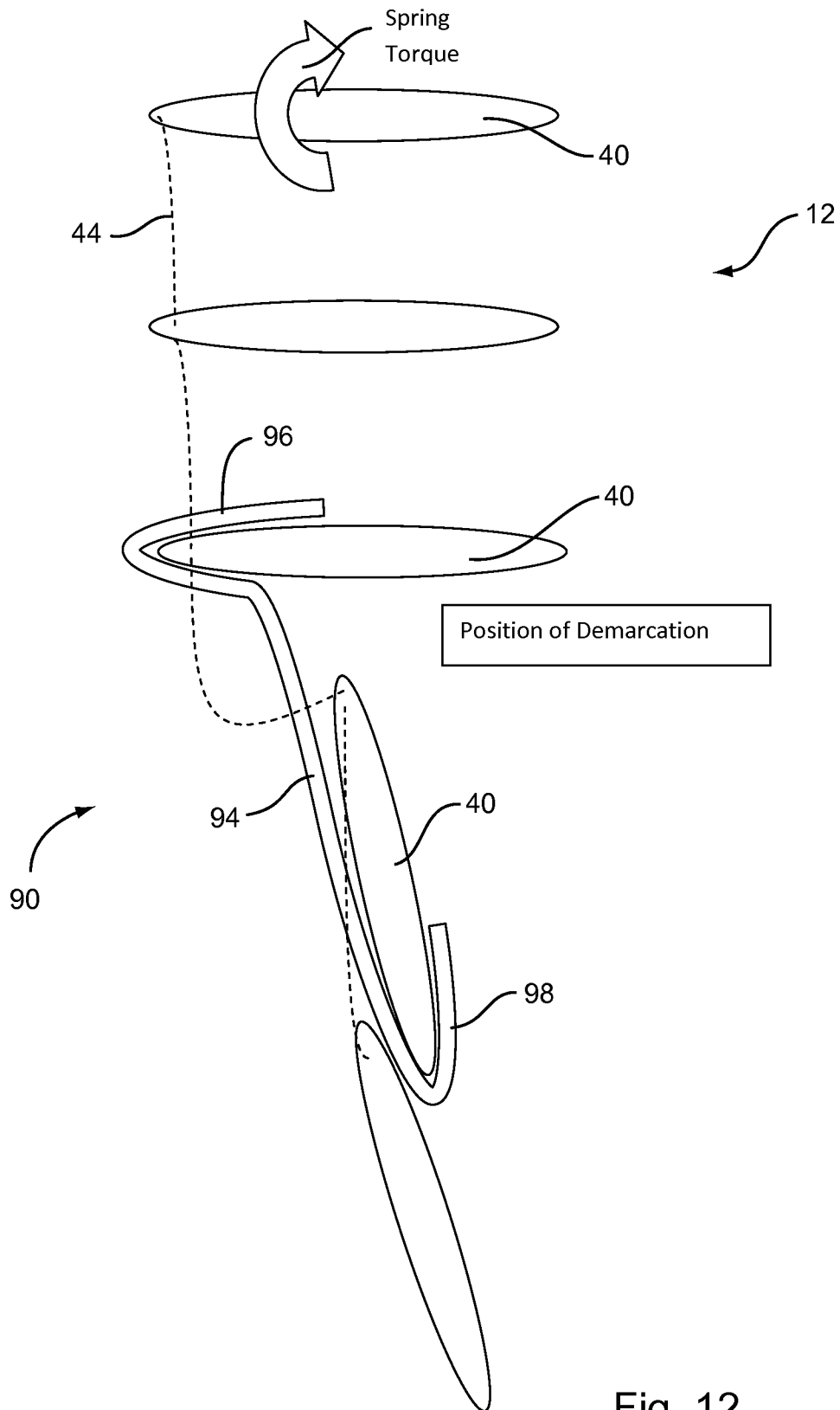

Fig. 12

INTERIOR SHUTTER-BLIND FOR WINDOWS WITH STACKABLE LOUVERS

CROSS REFERENCE TO RELATED APPLICATION[S]

This application is a continuation-in-part of the earlier U.S. Utility patent application entitled "PANELLESS SHUTTER," Ser. No. 13/460,326, filed Apr. 30, 2012, now pending, which is a continuation of the earlier U.S. Utility patent application entitled "PANELLESS SHUTTER," Ser. No. 12/424,469, filed Apr. 15, 2009, now U.S. Pat. No. 8,201,609, the disclosures of which are hereby incorporated entirely herein by reference.

BACKGROUND OF THE INVENTION

1. Technical Field

This invention relates generally to window covering and more particularly to an interior shutter-blind system.

2. State of the Art

Manufactured window coverings are broadly divided into three categories: shades, blinds, and shutters. Shades are typically single pieces of material that cover a window area and either roll or collapse to uncover the window. These include roller shades, cellular shades, and roman shades. Blinds are typically multi-piece assemblies comprising a number of essentially identical and coordinated slats, louvers, or vanes to cover the window area, and with a deployment system to establish uniform spacing when they are deployed over the window and compress that spacing into a close-stacked array to uncover the window.

Most blinds have the ability to modulate light passage by adjusting the coordinated orientation of the vanes (tilting, collapsing, rotating) to allow a variable degree of open area between adjacent vanes. Examples include venetian blinds, vertical blinds, and cellular blinds. Shutters are multi-piece and blind-like in their spaced and coordinated modulation of light passage by tilting vanes, but the vanes are fixed on their tilt axes in a rigid frame. The frames are typically hinge-mounted to the wall of the window covered, so that the shutter may be swung away from the window to uncover it. Such framed shutters are heavy, difficult to install, expensive, and require strong wall structure to bear the weight at the hinges. For this reason they are almost always installed professionally at significant cost and have been restricted to expensive homes.

Accordingly, there is a need for an affordable shutter-like window covering that provides the upscale appearance of a shutter without the costly custom installation and awkward, difficult swing-out mounting, while incorporating the stackable elements of a blind for ease of installation, view, and cleaning.

DISCLOSURE OF THE INVENTION

The present invention relates to an interior shutter-blind for windows, the shutter-blind including a frame and a plurality of louvers operatively coupled in the frame, the louvers being rotatable and stackable.

An embodiment of the present invention includes a shutter-blind system for windows. The system comprises a frame and a plurality of rotatable parallel louvers coupled within the frame. Each louver of the plurality of louvers is operatively coupled to adjacent louvers with a collapsible linkage. The system may further comprise a biasing member coupled to a first louver located at a first end of the plurality of louvers and

a resisting member coupled to a second louver located at a second end of the plurality of louvers. The biasing member pulls against the resisting member to maintain tension in the collapsible linkage. According to certain embodiments, all of the louvers of the plurality of louvers are rotated in a matched rotation in response to rotation of the second louver, preferably by means of the collapsible linkage. Further, all of the louvers are held in a position within their rotational range of motion, by the biasing member acting in response to operation of the resisting member.

Another embodiment of the present invention includes a tilting system for blinds comprising collapsible linkages coupled between adjacent louvers of a plurality of louvers, a biasing member coupled to a first louver located at a first end of the plurality of louvers, and a resisting member coupled to a second louver located at a second end of the plurality of louvers. The biasing member pulls against the resisting member to maintain tension in the collapsible linkages. Further, the plurality of louvers is rotated in response to rotation of the second louver.

Further still, another embodiment of the present invention includes a system for providing a wide range of window treatment sizes. The system comprises a frame assembly. The frame assembly comprises upper, lower, and opposing side frame elements. Each frame element includes first channels along the length, sized to receive substantially L-shaped joiner pieces that frictionally fit in the first channels to form and maintain accurate right-angle corners in the frame. The system may also include adjustable brackets for mounting in a range of window sizes.

The foregoing and other features and advantages of the present invention will be apparent from the following more detailed description of the particular embodiments of the invention, as illustrated in the accompanying drawings.

BRIEF DESCRIPTION OF THE DRAWINGS

FIG. 1 is a perspective view of an interior shutter-blind system.

FIG. 2 is an exploded perspective view of the interior shutter-blind system.

FIG. 3 is a close-up perspective view of a portion of stackable louvers of the interior shutter-blind system.

FIG. 4 is a perspective of a top rail assembly of the interior shutter-blind system.

FIG. 5 is a perspective view of a bottom rail assembly of the interior shutter-blind system.

FIG. 6 is a perspective view of a left side rail assembly of the interior shutter-blind system.

FIG. 7 is a perspective views of a right side rail assembly of the interior shutter-blind.

FIG. 8A is a front view of a moving rail assembly of the interior shutter-blind system.

FIG. 8B is a front view of interior components of a moving rail.

FIG. 8C is a perspective view of the interior components of a moving rail.

FIGS. 9A-9B are perspective views of a molding assembly of the interior shutter-blind system.

FIG. 10 is a perspective view of a plurality of louvers coupled between side frame elements (outer portions of the side frame elements are removed to show interior components of the side frame elements) with the moving rail engaging racks of the side frame elements, wherein the bottom louver is removed to show the engagement of the moving rail with the racks.

FIG. 11 is a side view of a top view-bottom privacy device for use with a shutter-blind system.

FIG. 12 is a side view of another top view-bottom privacy device for use with a shutter-blind system.

DETAILED DESCRIPTION OF EMBODIMENTS OF THE INVENTION

As discussed above, embodiments of the present invention relate to an interior shutter-blind for windows, the shutter-blind including a frame and a plurality of louvers operatively coupled in the frame, the louvers being rotatable and stackable.

Referring to the drawings, FIGS. 1-3 depict a shutter-blind system 10 comprising a plurality of louvers 12, a frame assembly 14 and a trim assembly 16. The frame assembly 14 comprises a lightweight frame assembly 14 including an upper element 20, a lower element 22, and two side elements 24 and 26. The upper element 20 and lower element 22 are coupled to the side elements 24 and 26 to form a rectilinear configuration. The frame assembly 14 comprises upper L-shaped connectors 52 of brackets 50 coupled to the upper element 20 (see FIG. 4) and lower L-shaped connectors 55 of brackets 54 coupled to the lower element 22 (See FIG. 5) that enforce rectilinearity of the frame assembly 14.

The plurality of louvers 12 includes rotatable parallel louvers 40 coupled within the frame assembly 14. Each louver 40 of the plurality of louvers 14 is operatively coupled to adjacent louvers 40 with a collapsible linkage 44.

With additional reference to the drawings, FIG. 6 depicts a first side frame element 24. The first side element 24 comprises a track 61 with a top block 60 coupled within the track. The top block 60 functions as a stop for the movement of travelers 62 within the track 61. The travelers 62 are configured to couple to louver connectors 42 (See FIG. 3), wherein the louver connectors 42 are rotatable within a socket 65 to allow for rotation of each louver 40 of the plurality of louvers 12. In some embodiments, the louver connector 42 is a ball that fits into a traveler socket 65 of the traveler 62. The first element 24 further comprises a bottom spacer 66 coupled to a bottom most traveler 62 in order to space the traveler 62 from the moving rail 28 of the frame assembly 14, wherein the spacer engages the moving rail 28 and limits upward movement of the traveler 62 relative to moving rail 28.

FIG. 7 depicts a second side frame element 26. The second side element 26 comprises track 71 with a biasing member 70 that comprises a biasing spring housed in a spring block 75 and a louver-engaging mechanism 77 that is operatively coupled between the biasing spring and a first louver 40 located at a first end of the plurality of louvers 12. In some embodiments, the biasing spring is a torsional spring that biases the rotation of the louver mechanism 77 in one of a clockwise or counter-clockwise direction.

The second side element 26 further comprises travelers 62 that move along the track 71. The travelers 62 are configured to couple to louver connectors 42, wherein the louver connectors 42 are rotatable within a socket 65 to allow for rotation of each louver 40 of the plurality of louvers 12. In some embodiments, the louver connector 42 is a ball that fits into a traveler socket 65 of the traveler 62.

The second side element 26 further comprises a resisting member 74. The resisting member 74 comprises a drag or brake 76 and louver-engaging mechanism 78. The louver-engaging mechanism 78 is operatively coupled between the drag 76 and the louver 40 located at a second end of the plurality of louvers 12. The drag 76 of the resisting member functions to resist rotation of the louver 40 located at the

second end of the plurality of louvers 12 and therefore resists rotation of all of the louvers 40 of the plurality of louvers 12 by means their connection through collapsible linkage 44.

In operation, the biasing member 70 pulls against the resisting member 74 to maintain tension in the collapsible linkages 44. In other words, the biasing member 70 operates to bias the plurality of louvers 12 to rotate in one of a clockwise or counter clock-wise rotation and the resisting member 74 operates to resist the rotation of the plurality of louvers 12. In particular embodiments, the resisting force of the resisting member 74 is greater than the force of the biasing member 70 to prevent unassisted rotation of the louvers 40 of the plurality of louvers 12. Accordingly, all of the louvers 40 of the plurality of louvers 12 are rotated in a matched rotation in response to rotation of the louver located at the second, drag-coupled end of the plurality of louvers 12, and all of the louvers are held in congruent tilt position with respect to that of the second, drag coupled louver, in response to operation of the biasing member 70, through tensioned collapsible linkage 44.

Because the resisting member 74 creates a drag force, it resists the rotation of the biasing member 70, wherein as the biasing member 70 biases the first louver to rotate in a particular direction while the resisting member resists rotation of the second louver located at the second end of the plurality of louvers 12. The collapsible linkages are coupled to all of the louvers 40 of the plurality of louver 12, wherein as the first louver is biased to rotate a particular direction and the second louver is resistant to rotation, a tension is created along the collapsible linkages 44, wherein all of the louvers 40 are in a matched rotation (congruent tilt) and are maintained in a matched rotated position because of the tension created in the collapsible linkages 44.

The first side element 24 may include a rack 72 along the length of the track 61, wherein the rack 72 comprises a plurality of evenly spaced apertures along the length of the rack 72. The second side element 26 may also include a rack 72 along the length of the track 71, wherein the rack 72 comprises a plurality of evenly spaced apertures along the length of the rack 72. A moving rail 28 may be operatively disposed between the side elements 24 and 26, wherein the moving rail 28 is parallel to and between the upper and lower elements 20 and 22 of the frame assembly 14. The moving rail 28 includes a shaft 81 extending there through with gear members 80 coupled on opposing ends of the shaft 81. The gear members 80 comprise gears 83 engaged for common rotation at either end of the shaft 81. The gear members 80 further include and end block 82, a spring 84, a plunger 86 that engages a gap 85 in gear 83. The end block 82 operationally retains the spring 84 coupled to the plunger 86 within the end block 82. The teeth 65 of the gears 83 engage the racks 72 of the tracks 61 and 71. For example, the teeth 65 of the gear 83 engage the apertures of the rack 72, wherein as the gear 83 rotates, the teeth 85 of the gear 83 engage adjacent apertures and the gear 83 moves along the length of the rack 72. The gears 83 are coupled together through the shaft 81 to move together and maintain a substantially horizontal position for middle rail 28 as they engage the rack members 72 in side rails 24 and 26. The moving rail 28 further comprises a locking device 87 that comprises the plunger 86 and the spring 84 to prevent rotation of the gears 83 except when released by the hands of an operator seeking to reposition the moving rail 28. When released, the gears 83 are free to rotate, doing so in response to lifting or lowering the moving rail 28, wherein the gears 83 operatively engage the racks 72 and rotate along the length of the racks 72 as described previously. Once a desired location of the moving rail 28 is selected, the operator can engage the

locking device **87** again and prevent rotation of the shaft **81** and movement of the moving rail **28**.

According to particular embodiments, and with additional reference to FIG. **10**, the moving rail has gear members **80** on opposing ends of the rail **28**. The engagement and disengagement of the locking devices **87** occurs in response to operation of the plungers **86**. The springs **84** bias the plungers **86** away from each other and away from the ends of the moving rail **28**. The locking devices **87** are coupled to the plungers **86** such that movement of the plungers **86** results in movement of the locking devices **87**. The biased plungers **86** also bias the locking devices **87** to extend between adjacent teeth **85** of the gear **83**, preventing rotation of the gear **83** engaged onto the shaft **81**. This keeps the moving rail **28** from moving up or down. To actuate or move the moving rail **28**, an operator may insert index fingers outboard of triggers of the plunger **86** and by pressing his fingers toward one another, compresses both springs **84** and draws in the plungers **86** and the locking device **87** away from the teeth **85** of the gears **83**, thereby freeing the gears **83** and shaft **81** to rotate together and thereby to move up and down the racks **72** in the side rails. The user fingertips also bear the weight of the moving rail **28** to move it to a new position, wherein release of the pressure on the triggers re-locks the gears **83** in the new place. The engagement of the gears **83** on the shaft **81** compels them to rotate altogether as one, as the two gears **83** engage the two racks **72**, thereby preventing either end of moving rail **28** from rising or falling with respect to the other end, and so maintaining the moving rail **28** in parallel relation to top and bottom rails **20** and **22** under all operating conditions and up or down movements of the rail **28**.

Assembly of the shutter-blind system **10** includes assembling the frame elements **20**, **22**, **24**, **26** and **28**; and placing them within a window opening. For example, the top frame element **20** may be coupled within the window opening adjacent a top end of the window opening by coupling the brackets **50** with adjustable screws to the surrounding surfaces of the window opening. Typically, to install the shutter-blind, the frame is first assembled on a horizontal surface by engaging the L-shaped members **52** of the top rail **20** to the side rails **24** and **26**. Then the moving rail **28** is inserted, engaging the gears **83** into the racks **72** of the side rails **24** and **26**. Last the bottom rail **22** is fitted to the other ends of the side rails **24** and **26** to complete the frame **14**. Then mounting brackets **50** and **54** are secured to the window frame at its corners and the assembled frame is lifted into position, by engaging the ends of the lower adjusting screws **59** into receiving slots in the lower brackets **54**. Extending the upper screws **57** to engage them in the slots of the upper brackets **50**, sliding the frame laterally to center it in the opening, and tightening screws **57** and **59** to level and vertically center the frame completes the mounting of the frame to the window opening.

Then the assembly includes coupling a plurality of louvers **12** (equivalently, slats or vanes) between the side elements **24** and **26**, wherein the louvers **40** of the plurality of louvers **12** are parallel to and between the upper element and the moving rail **28** that is also coupled between the side elements **24** and **26**. The louvers **40** of the plurality of louvers **12** are held in uniform collapsible spacing by collapsible spacers **67** and travelers **62** located at opposing ends of each louver **40**, which allow rotation of the louvers **40** about their long axes. Further, a first louver is coupled to a biasing member **70** located at a first end of the plurality of louvers **12**. The biasing member **70** biases the rotation of the first louver, and all louvers through collapsible spacers **67**, in a direction that tends to bring each louver **40** into contact with the adjacent louver **40**; that is an

equivalent extreme tilt position, a maximum light blocking position where louvers overlap and abut one another (See FIG. **10**).

A collapsible linkage **44** is installed and connects one outer end corner (or other position away from the rotation axis) of each louver **40** to its adjacent louvers **40** in the plurality of louvers **12**. The lengths of the collapsible linkages **44** are substantially equivalent to the length of the collapsible spacers **67** when fully extended and allow contact stacking of the louvers **40** when collapsed (See FIG. **10**).

Once the plurality of louvers **12** are operatively coupled within the frame assembly **14**, optionally, a fascia trim assembly **16** may be installed to cover any gaps between the frame assembly and the window opening to which it is installed. The trim assembly **16** may include upper trim element **30**, lower trim element **32** and side trim elements **34** and **36**. Each trim element includes deformable projections **38** inserted into channels **35** on the back of trim elements **30**, **32**, **34** and **36**. The upper frame element **20** includes a second channel **53**, the bottom frame element **22** includes a second channel **56**, the first side frame element **24** includes a second channel **63** and the second side frame element **26** includes a second channel **73**. The trim elements **30**, **32**, **34** and **36** are affixed to a corresponding frame element **20**, **22**, **24** and **26** in response to pressing the projections **38** coupled to each trim element **30**, **32**, **34** and **36** into the channels **53**, **56**, **63** and **73**. Further, the trim elements **30**, **32**, **34** and **36** may be coupled to proper adjacent trim elements, such as the upper trim element **30** coupled to the side trim element **36** by use of connector **37**. In some embodiments, connector **37** may be an elbow connector, wherein the connector **37** couples the upper trim element **30** with the side trim element **36** at a substantially right angle. Connectors **37** may be slidingly engaged with channels **35**.

Referring further to the drawings, FIGS. **11** and **12** depict embodiments of top view-bottom privacy device **90** according to the present invention. As indicated above, the plurality of louvers **12** rotate in a matched rotation and continue to do so if there is no interference. Generally, the position of the louver **40** located at the second end of the plurality of louvers **12** is coupled to a resisting member **74** and dictates the general orientation of all of the louvers above it. The top view-bottom privacy device **90** interrupts the force relationship between the top louver **40** coupled to the biasing member **70** and bottom louver **40** coupled to the resisting member **74** in such a way that the top louvers tend to remain in an open position while the bottom louvers tend to remain in a closed position. The position of demarcation between top open and bottom closed may be selected arbitrarily by a user. To achieve top view-bottom privacy, a force decoupling device **92** may be introduced at the point at which it is desired to maintain louvers below it closed and louvers above it opened, or point of demarcation. In some embodiments, more than one force decoupling device(s) **92** may be utilized. The purpose of the force decoupling device **92** is to prevent the biasing member **70** from transmitting torque to the louvers immediately below the desired view through demarcation point. For example, one force decoupling device **92** may be placed in contact with a louver **40** to stop rotation of the louver **40** an open position and a second force decoupling device may be placed in contact with an adjacent louver **40** to restrain the adjacent louver **40** from rotating, thereby keeping it in the closed position and further keeping all louver below it in a closed position as shown in FIG. **11**.

The top view-bottom privacy device **90** may also be in the form of a clip device **94**, wherein the clip **94** engages two adjacent louvers **40** at the position of demarcation. The clips has a first receiving member **96** and a second receiving mem-

ber **98**, wherein the first receiving member couples to a louver **40** to hold it in an open position at the point of demarcation and the second receiving member **98** couples to the lower adjacent louver **40** to maintain it in a closed position. Alternatively, independent “holders” could be placed either on appropriate locations on the vertical rail near each louver that needs to be restrained or could extend from the ends of each louver to restrain the louver against the vertical rail.

According to particular embodiments, the frame elements are produced in multiple predetermined sizes with vertical dimensions corresponding to whole numbers of uniformly spaced louvers, and the extension of trim elements is sufficient to cover a range of window sizes corresponding to each incremental frame size. Further, the frames are produced in multiple predetermined sizes with width dimensions incrementally sized to enable the extension of trim elements to cover a range of window sizes corresponding to each incremental frame size. Because the trim elements cover the gap between frame elements and window opening, and the trim elements have a particular width, the frame does not have to be custom cut to fit within the window as do conventional shutters. Most windows vary, even if slightly, from the common measurements for a particular window size, and embodiments of the present invention provide the opportunity to fit within a wide range of windows even those that are not exactly the common length since the trim elements cover any gap between the frame elements and the window opening.

Additionally, window openings that have a great width may utilize multiple frame assemblies coupled adjacent to each other, wherein the trim elements may then be utilized to cover all of the frame elements, and further cover any gaps between the frame elements and the window opening.

It is contemplated that at the point of sale, such as in a home goods store, the frame elements, louvers and trim elements may be pre-packaged to accommodate a wide range of window sizes. For example, and not as a limitation, vertical frame elements of the same size may be packaged together. The store may stock varying lengths of two pack vertical frame elements. Likewise, horizontal frame elements of the same size may be packaged together, wherein the store may stock varying lengths of two pack horizontal frame elements, together with the corresponding moving rail element. The vertical and horizontal frame elements are chosen to fit a particular window and may be purchased at the store. In this way, a user may have a variety of window sizes that can utilize the shutter-blind assembly according to embodiments of this invention. The trim elements are chosen based on the lengths of the vertical and horizontal frame elements, or are packaged together with frame elements of corresponding dimension.

As previously stated, vertical dimensions of the vertical frame elements correspond to whole numbers of uniformly spaced louvers. The store may stock a package of a predetermined number of louvers to which the vertical dimension corresponds. For example, the predetermined number may be 3, however, any number may be utilized with departing from the scope of this invention.

The embodiments and examples set forth herein were presented in order to best explain the present invention and its practical application and to thereby enable those of ordinary skill in the art to make and use the invention. However, those of ordinary skill in the art will recognize that the foregoing description and examples have been presented for the purposes of illustration and example only. The description as set forth is not intended to be exhaustive or to limit the invention to the precise form disclosed. Many modifications and variations are possible in light of the teachings above without departing from the spirit and scope of the forthcoming claims.

The invention claimed is:

1. A shutter-blind system for windows, the system comprising:
 - a frame assembly;
 - a plurality of rotatable parallel louvers coupled within the frame assembly, each louver of the plurality of louvers operatively coupled to adjacent louvers with a collapsible linkage, wherein the collapsible linkage couples one outer end corner of each louver to one outer end corner of an adjacent louver on a same side of the plurality of louvers;
 - a biasing member coupled to a first louver located at a first end of the plurality of louvers; and
 - a resisting member coupled to a second louver located at a second end of the plurality of louvers, the biasing member pulling against the resisting member to maintain tension in the collapsible linkages, wherein:
 - all of the louvers of the plurality of louvers are rotated in a matched rotation in response to rotation of the second louver; and
 - all of the louvers are held in position in response to operation of the biasing member acting against the resisting member.
2. The blind system of claim 1, wherein the resisting member is a frictional resisting member.
3. The blind system of claim 1, wherein the collapsible linkage is flexible.
4. The blind system of claim 1, wherein the collapsible linkage is jointed.
5. The blind system of claim 1, further comprising a top view-bottom privacy device, wherein the louvers above a point of demarcation are held in an open position and the louvers below the point of demarcation are held in a closed position.
6. The blind system of claim 5, wherein the top view-bottom privacy device comprises force decoupling devices that retain a louver in the open position and an adjacent louver in the closed position, the force decoupling devices located at the point of demarcation.
7. The blind system of claim 5, wherein the top view-bottom privacy device comprises a clip device comprising a first receiving member and a second receiving member, wherein the first receiving member couples to a louver and retains it in the open position and the second receiving member couples to a lower adjacent louver and retains it in the closed position, the clip device located at the point of demarcation.
8. The blind system of claim 1, wherein in one of the first or second ends of the plurality of louvers is moveable in a direction transverse to axes of rotation of the plurality of louvers.
9. The blind system of claim 8, further comprising a moving rail coupled at the moveable first or second end.
10. The blind system of claim 9, wherein the moving rail comprises a shaft torsionally connected with gears at each end that engage the side frame elements.
11. The blind system of claim 10, wherein the opposing side frame elements comprise racks, wherein the gears of the moving rail engage the racks to maintain the moving rail substantially level during movement.
12. A tilting system for blinds comprising:
 - collapsible linkages coupled between adjacent louvers of a plurality of louvers, wherein the collapsible linkage couples one outer end corner of each louver to one outer end corner of an adjacent louver on a same side of the plurality of louvers;

a biasing member coupled to a first louver located at a first end of the plurality of louvers; and
a resisting member coupled to a second louver located at a second end of the plurality of louvers, wherein the biasing member pulls against the resisting member to maintain tension in the collapsible linkages;
wherein the plurality of louvers are rotated in response to rotation of the second louver.

13. The tilting system of claim **12**, wherein the resisting member is a frictional resisting member.

14. The tilting system of claim **12**, wherein the spacing member is flexible.

15. The tilting system of claim **12**, wherein the spacing member is jointed.

16. The tilting system of claim **12**, wherein in one of the first or second ends of the array of louvers is moveable in a direction transverse to axes of rotation of the array of louvers.

17. The tilting system of claim **16**, further comprising a moving rail coupled at the moveable first or second end.

18. The tilting system of claim **17**, wherein louvers rotate in response to the moving rail contacting the louvers as it is moved toward the opposing non-moving first or second end.

* * * * *