

H. D. CHANCE.

Improvement in Shutter-Fasteners.

No. 132,630.

Patented Oct. 29, 1872.

Fig. 2.

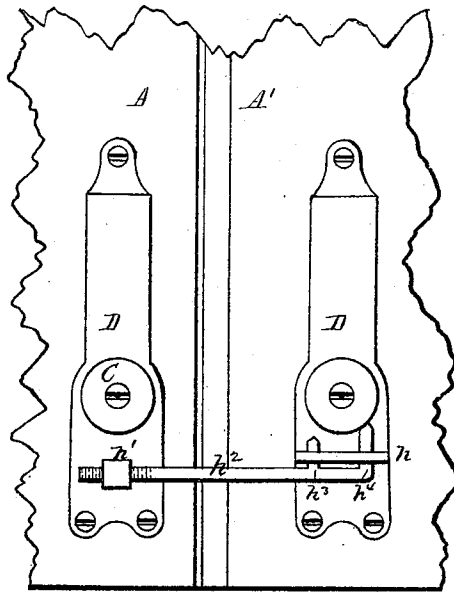
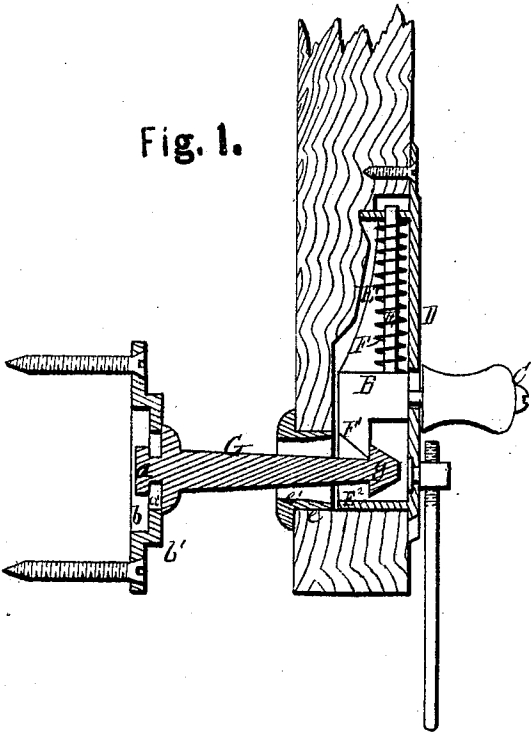

WITNESSES.

E. A. Bates.

W. E. Upham.

INVENTOR.

Hiram D. Chance,
Chipman Foster & Co.,
Attys.

UNITED STATES PATENT OFFICE.

HIRAM D. CHANCE, OF LLEWELLYN, PENNSYLVANIA, ASSIGNOR OF ONE-HALF OF HIS RIGHT TO HARRY C. CHANCE, OF SAME PLACE.

IMPROVEMENT IN SHUTTER-FASTENERS.

Specification forming part of Letters Patent No. 132,630, dated October 29, 1872.

To all whom it may concern:

Be it known that I, HIRAM D. CHANCE, of Llewellyn, in the county of Schuylkill and State of Pennsylvania, have invented a new and valuable Improvement in Combined Shutter and Blind Fasteners; and I do hereby declare that the following is a full, clear, and exact description of the construction and operation of the same, reference being had to the annexed drawing making a part of this specification and to the letters and figures of reference marked thereon.

Figure 1 of the drawing is a representation of a sectional view, showing the device for holding shutter back. Fig. 2 is a front view, showing the device for holding shutters together.

This invention has relation to shutter or blind fasteners; and consists in the construction, arrangement, and combination of novel devices whereby the blinds may be fastened when closed, or open, or when partly closed, all as hereinafter described.

Referring to the accompanying drawing, A A' represent the correspondingly-rabbeted stiles of a pair of hinged window blinds or shutters, to each of which is attached a latch having a vertically-sliding spring-bolt, B, operated through the medium of a knob, C, projecting from the inner side of the shutter, its shank passing through a slotted face-plate, D. The bolt B plays within a metallic case inserted or embedded in the stile near the bottom thereof, and is constructed with a shank, E, encircled by a spiral spring, F, and with a beveled projecting head, F'. The latch-case E¹ is constructed with a cylindrical socket, E², corresponding with an aperture, e, in the stile, bored from the outside thereof, and provided with a flanged metallic bushing, e'. The head of the bolt enters the socket E², as shown. The latch is only used for the purpose of fastening the blind or shutter to the house-wall when it is thrown open. G designates a catch used in connection with the latch, and consisting of a horizontal post projecting from the wall, and provided with a conical, shouldered, or otherwise beveled head, g. When the blind or shutter is thrown open the head g enters the socket E² and is caught by the bolt automatically.

The catch is released by raising the bolt. The post G may be secured to the wall in any convenient way; but to enable the post to be adjusted laterally, in order to compensate for the shrinking or expansion of the shutter, the inner end thereof is constructed with a T-shaped projection, a, which enters a recess, b, in a bracket, b', attached to the wall through a slot, a'. After said projection is put through the slot a' it is turned around so as not to fall out, after which the post may be moved according as required. The projection a fits its socket closely, so as not to move unless slight force be used. Attached to one of the plates D is a horizontal flange, h, having two holes bored at a distance apart. To the other plate D is pivoted a block, h¹, having a threaded aperture, into which is screwed the end of a hook-shank, h², provided with two fingers, h³ h⁴, corresponding to the holes in the flange h.

When the blinds are closed, both fingers h³ h⁴ enter the holes in the flange from the under side and thereby secure the blinds. When it is desired to hold the blinds partly open or bowed, the finger h⁴ is inserted in the hole nearest the crevice between the blinds. The shank h² may be adjusted lengthwise to adapt it to the shrinkage or expansion of the blinds, or to enable the distance apart of the blinds when bowed to be regulated by turning it in the block h¹.

What I claim as my invention, and desire to secure by Letters Patent, is—

1. In a shutter-fastener, the hook h² having fingers h³ h⁴, the flange h having openings to receive said fingers, and the pivoted nut h¹, constructed and arranged substantially as specified.

2. In a shutter-fastener, the catch-post G having the T-shaped projection a, in combination with the wall-bracket b' having the recesses b and slot a', substantially as and for the purpose specified.

In testimony that I claim the above I have hereunto subscribed my name in the presence of two witnesses.

HIRAM D. CHANCE.

Witnesses:

GEO. SPONSLER,
J. D. DIETRICH.