

Nov. 15, 1955

A. C. BARDON

2,723,407

WATER DRIVEN ROTARY BRUSH

Filed July 1, 1955

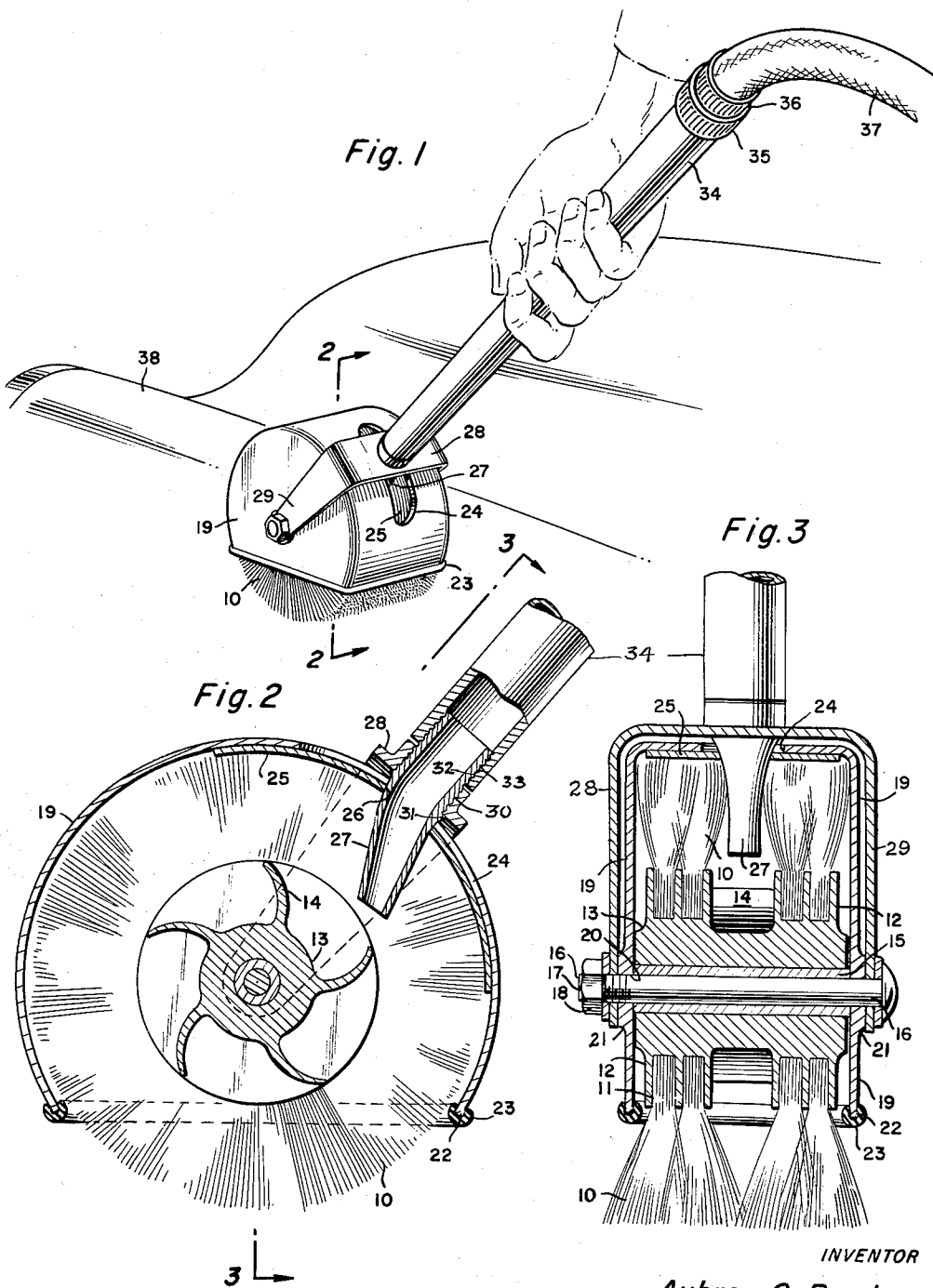

INVENTOR  
*Aubrey C. Bardon*

BY

*Agates Dowell*  
ATTORNEY

1

2,723,407

## WATER DRIVEN ROTARY BRUSH

Aubrey Clyde Bardoan, Tuscaloosa, Ala.

Application July 1, 1955, Serial No. 519,379

3 Claims. (Cl. 15—24)

This invention relates to cleaning including by brushing and scrubbing and flushing with water and includes the equipment employed for such operations, particularly where surfaces to be cleaned are dirty or muddy and which require both wetting and brushing in order to remove the accumulation thereon.

The invention relates to a water driven rotary brush which can be attached to the end of a flexible water hose and used for washing an automobile or other object, to thoroughly brush the surface and flush such surface with water to clean the same.

Rotary brushes operated by the force of water have not been satisfactory for various reasons including the fact that they were too complicated, there was not the proper relation between the areas of the brush surface and the amount of water supplied, or else the full and necessary force of the water was not sufficiently utilized for rotating the brush. Further, the exposed portion of the brush was located so that water was discharged in a manner to cause wetting of a relatively wide area and the operator, instead of being confined to an effective area which it was desired to wash.

It is an object of the invention to overcome the disadvantages above enumerated and to provide a simple and inexpensive water driven rotary brush with a handle by which it can be conveniently manipulated, such handle having a connection at its outer end for attachment to a flexible water hose so that water supplied therefrom through the handle will be discharged against vanes of an impeller brush unit with the impeller located centrally thereof but constructed so that the bristles spread and provide a unitary or solid operating area of the brush body. A housing is provided for the brush unit, said housing having an opening through which the operating portions of the brush are exposed. A gasket is located around the opening in the housing to prevent injury to any surface to which the brush is applied.

Other objects and advantages of the invention will be apparent from the following description taken in conjunction with the accompanying drawing wherein:

Fig. 1 is a perspective illustrating one application of the invention and the use of the same;

Fig. 2, a section on the line 2—2 of Fig. 1; and

Fig. 3, a section on the line 3—3 of Fig. 2.

Briefly stated, the present invention is a water driven rotary brush which can be attached to the end of a flexible water hose and used for washing the surface of an automobile or other object where it is desired simultaneously to brush as well as flush the surface with water for cleaning. A combination impeller brush unit is provided, including a hub on which blades are located in a generally radial direction. At each side of the blades are rotary brushes, the bristles of which unite to form a solid body for application to a surface to be treated. The impeller brush unit is mounted in a casing having a rubber lipped opening through which the bristles of the brushes project. In the center of the casing on the side remote from the opening is a radial handle slot with a

2

curved plate beneath and closing the same but permitting angular adjustment. A discharge tip is provided to discharge water onto the lower portion of the impeller to rotate the brush to cause the exposed portion to move away from the operator so that water will not be thrown onto the operator. The discharge tip is carried by a yoke having perforated extremities in which the spindle of the device is located so that the yoke and an attached handle may oscillate through an arc corresponding to the length of the slot in the casing. The side plate which closes such slot is attached to the discharge tip and the upper end of the tip extends through the yoke and has threads on its upper end attached to the handle through which water can flow from a flexible water hose attached to the outer end of the handle.

With continued reference to the drawing, the device of the present invention comprises a water driven rotary brush including bristles 10 for brushing the surface of an object to which they are applied. The bristles 10 are mounted in two annular groups side by side in openings 11 in spaced parallel supporting disks 12 of substantial thickness and carried by a hollow hub 13.

Between the disks 12 there are mounted a series of impeller blades 14 against which water or other fluid is adapted to be directed for producing rotation of the impeller brush unit or water motor. The impeller brush unit is supported by a sleeve 15 on a spindle or bolt 16 having a threaded end 17 for the attachment of a nut 18.

A house or casing 19 is provided for the impeller brush unit having an opening 20 in which the bolt or spindle 16 is received, and about the opening 20 the housing or casing may have a reinforcing boss or thickened portion 21 to strengthen the casing in the area in which it is supported. The opening 20 in the housing 19 has a thickened lip 22 about which a gasket 23 is disposed for preventing injury to a surface to which the brush is applied.

As disclosed in Fig. 2 the bristles project a substantial distance from the casing so that they may flatten onto the surface area to which they are applied and at the same time water within the casing will drive the blades of the impeller and simultaneously flow transversely between the bristles so that adequate water can be supplied to the operating brush area.

In order that water may be admitted, an opening in the form of a slot 24 is provided in the wall of the casing and a curved plate 25 is provided in order to permit adjustment but close such slot, such plate having an opening 26 for an angular discharge tip 27 located in a position to discharge water onto the blades 14 of the impeller.

The discharge tip 27 is carried by a yoke 28 having perforated extremities 29 in which the bolt or spindle 16 is located so that the yoke may oscillate through an arc corresponding to the length of the slot 24, the plate 25 being attached to the tip 27 so that it is held in place and is slidable within the casing 19. The yoke 28 has a threaded opening 30 in which the tip 27 is located, such tip having a shoulder 31 which engages the under side of the yoke to form a stop.

The outer end of the tip is provided with threads 32 which engage the threads 30 and onto which threads 33 of a handle 34 are attached, the upper end of the handle being provided with a coupling 35 for the attachment to the coupling 36 of a flexible water hose 37.

It will be apparent from the foregoing that when the handle 34 is gripped in the hand and the device is applied, the bristles 10 will spread over the fender or other surface portion 38 of the automobile or other object being cleaned. At the same time water flowing through the hose 37 and the handle 34, will be discharged through the tip 27 onto or against the impeller blades thereby producing rotation of the impeller brush unit, the bristles

3

of the brush being supplied with water to perform the cleaning operation.

It will be obvious to those skilled in the art that various changes may be made in the invention without departing from the spirit and scope thereof and therefore the invention is not limited by that which is illustrated in the drawing and described in the specification, but only as indicated in the accompanying claims.

What is claimed is:

1. A water driven rotary brush for attachment to the end of a flexible water hose and usable for brushing a surface and flushing the same with water for cleaning, comprising a spindle, a hub rotatable on said spindle, an impeller brush unit mounted on said hub having an impeller between rotary brushes, a housing for and of a configuration to snugly receive said impeller brush unit and having a brush exposing opening in one side and a slot in remote relation thereto, an internal plate for covering said slot and having a central opening therein, a discharge tip fixed in said central opening and having its inner end eccentrically disposed below the axis of the impeller to cause the lower surface of the latter to move forwardly away from said tip, a yoke having its ends journaled on the ends of said spindle and connected to said discharge tip, a handle connected to the outer end of said tip, and means for connecting a flexible water hose to the outer end of said handle for supplying water to said impeller brush unit to produce rotation of the same and to flush the brushed area, and a gasket about the opening in said housing to prevent marring the surface of an object against which the brush is brought into contact.

2. In combination, an impeller, a rotary brush at each side of said impeller and connected in a manner such that when said impeller is rotated the brushes likewise

4

will be rotated, said brushes being of a diameter substantially greater than said impeller so that the free ends of the bristles of one brush will overlap the bristles of the other brush and overlie said impeller, and a housing for said brushes and impeller of a size and configuration to snugly receive the same, said housing having a brush-exposing opening in its circumferential portion in spaced relation to said opening, means for supplying water under pressure to said housing against said impeller nearer one end of said opening than the other for producing rotation of said impeller and brushes and in a manner such that when the brushes are rotated they will have a tendency to discharge water away from instead of toward said handle.

3. A device of the character described comprising a pair of spaced rotary brushes and an impeller between the same, the bristles of said brushes being of a length such that when in use the operative area of the brushes will overlap and combine substantially as a single brush, a housing for said brushes and impeller having a discharge opening for exposing the bristles of the brushes at one side, and a water-supplying handle at the opposite side of said housing having a discharge portion arranged to discharge water eccentrically against the lower half of the impeller to cause it to rotate and with such lower portion turning in such discharge opening in a direction away from said handle.

#### References Cited in the file of this patent

#### UNITED STATES PATENTS

978,461	Linegar et al. ....	Dec. 13, 1910
1,053,035	Houghland .....	Feb. 11, 1913
1,817,644	Pope .....	Aug. 4, 1931