

(19)



(11)

EP 3 989 679 B1

(12)

EUROPEAN PATENT SPECIFICATION

(45) Date of publication and mention of the grant of the patent:

15.01.2025 Bulletin 2025/03

(51) International Patent Classification (IPC):
H05B 6/12 (2006.01)

(52) Cooperative Patent Classification (CPC):
H05B 6/1209; H05B 2206/022

(21) Application number: **21203140.5**

(22) Date of filing: **18.10.2021**

(54) **AN INDUCTION HEATING DEVICE**

EIN INDUKTIONSHHEIZGERÄT

UN DISPOSITIF DE CHAUFFE A INDUCTION

(84) Designated Contracting States:

**AL AT BE BG CH CY CZ DE DK EE ES FI FR GB
GR HR HU IE IS IT LI LT LU LV MC MK MT NL NO
PL PT RO RS SE SI SK SM TR**

(30) Priority: **21.10.2020 TR 202016780**

(43) Date of publication of application:
27.04.2022 Bulletin 2022/17

(73) Proprietor: **Vestel Beyaz Esya Sanayi ve Ticaret
A.S.
45030 Manisa (TR)**

(72) Inventor: **ERCOPUR, Turan
45030 Manisa (TR)**

(74) Representative: **Cayli, Hülya
Paragon Consultancy Incorporated
Koza Sokak No: 63/2 GOP
Cankaya
06540 Ankara (TR)**

(56) References cited:
**EP-A1- 2 775 785 EP-A1- 3 675 600
WO-A1-2015/049602 US-A1- 2016 057 815**

EP 3 989 679 B1

Note: Within nine months of the publication of the mention of the grant of the European patent in the European Patent Bulletin, any person may give notice to the European Patent Office of opposition to that patent, in accordance with the Implementing Regulations. Notice of opposition shall not be deemed to have been filed until the opposition fee has been paid. (Art. 99(1) European Patent Convention).

Description**Technical Field**

[0001] The present invention relates to induction heating devices.

Background of the Invention

[0002] Heating devices such as cookers are used for heating products in kitchenware such as pots, pans, or coffee pots. Said heating process can be provided with various heating elements. In conventional applications, the heating process is provided by burners in which a flammable gas such as natural gas is burned. However, in such applications, the flame resulting from the burning of the gas can create a safety problem. In order to solve this problem, electric heating devices are used in the known art. In electric heating devices, a resistance type heating element or an induction heating structure can be used. Induction heating devices are more popular among users since they operate more efficiently than heating devices with resistance.

[0003] In induction heating devices, at least one induction coil is positioned under a ceramic or glass upper surface. When said induction coil is energized, it creates magnetic waves. These magnetic waves heat the vessel located on the upper surface and containing a compatible metal.

[0004] Induction heating devices also comprise a carrier plate on which the induction coil is positioned and an electronic board that enables the induction coil to be energized in a controlled manner. In order for the heating device to be operated reliably, said induction coils must be fixed to the carrier plate. Said fixing process in the known art is carried out by fasteners such as screws. However, using screws for the connection process both causes a long production time and increases production costs.

Brief Description of the Invention

[0005] The present invention provides a heating device which comprises at least one body; at least one carrier plate located in the body; at least one induction coil located on the carrier plate; at least one electronic board for controlling operation of the induction coil; and at least one upper surface located on the induction coil. The heating device further comprises at least a first connection member located on the carrier plate, which has at least one vertical portion extending upward from the carrier plate and at least one horizontal portion located on the side of the vertical portion distal to the carrier plate; at least a second connection member extending upward from the carrier plate; at least one base plate located in the lower part of the induction coil; at least a first slot in the base plate suitable for accommodating the vertical portion of the first connection member; and at least a second

slot in the base plate suitable for accommodating the second connection member.

[0006] In the heating device according to the present invention, the induction coil is connected to the carrier plate by inserting the first connection member and the second connection member located on the carrier plate into the first slot and the second slot located on the base plate of the induction coil. Therefore, the connection process is carried out in an easy and reliable manner.

[0007] Patent document no. EP2775785A1 discloses an induction hob. Said induction hob comprises a coil carrier plate, an induction coil and a cooktop plate in a stacked arrangement. Said induction coil is supported on the coil carrier plate by means of at least one elastic support element. Said support element is either attached to the induction coil or the coil carrier plate or the cooktop plate.

[0008] Another patent document no. EP3675600A1 discloses an induction hob with means for holding a conductive cable. Said induction hob is connected to top plate by lugs provided on inductor support and folding tabs provided on the top plate. According to this document, for connecting the induction hob to the top plate, said lugs are positioned near the folding tabs and said folding tabs are folded over the lugs.

[0009] Another patent document no. US2016057815A1 discloses an induction cooking appliance and method for assembling same. Said induction cooking appliance comprises a cooktop having an upper surface and an opposing lower surface, and an induction element positioned below the cooktop in the vertical direction, the induction element contacting the lower surface of the cooktop. The induction cooking appliance further includes a mount bracket connected to the lower surface of the cooktop, and a mount plate connected to the mount bracket and positioned below the induction element in the vertical direction, the induction element connected to the mount plate.

[0010] Another patent document no. WO2015049602A1 discloses an induction hob apparatus. Said induction hob apparatus comprises at least one heating element which is provided for heating cookware, at least one partition element which is provided in an installation position for carrying the at least one heating element, and a fastening unit which is provided for fastening the at least one heating element and the at least one partition element to one another. According to this document, said fastening unit is at least partially in the form of a locking unit.

Object of the Invention

[0011] An object of the present invention is to provide a heating device in which the induction coil of the heating device is easily connected to the carrier plate.

[0012] Another object of the present invention is to provide a durable and reliable energy heater device.

Description of the Drawings

[0013] Exemplary embodiments of the heating device according to the present invention are illustrated in the attached drawings, in which:

Figure 1 is an exploded view of the heating device according to the present invention.

Figure 2 is a perspective view of a carrier plate in the heating device according to the present invention.

Figure 3 is a side view of the carrier plate in the heating device according to the present invention.

Figure 4 is a perspective view of a connection detail of the carrier plate in the heating device according to the present invention.

Figure 5 is a perspective view of another connection detail of the carrier plate in the heating device according to the present invention.

[0014] All the parts illustrated in figures are individually assigned a reference numeral and the corresponding terms of these numbers are listed below:

Heating device	(C)
Body	(1)
Electronic board	(2)
Switching element	(2a)
Cooling block	(2b)
Carrier plate	(3)
First connection member	(3a)
Second connection member	(3b)
Induction coil	(4)
Upper surface	(5)
Base plate	(6)
First slot	(6a)
Second slot	(6b)

Description of the Invention

[0015] Heating devices used for heating and/or cooking the products in a vessel may comprise various heating elements for the heating process. Heating devices comprising an induction coil for the heating process are called induction heating devices. Such a heating device comprises an induction coil, as well as at least one carrier plate to which the induction coil is connected. The present invention provides an induction heating device which enables the induction coil to be connected to the carrier plate in a practical and reliable way.

[0016] The heating device (C) according to the present invention, as illustrated in Figures 1-15, comprises at least one body (1); at least one carrier plate (3) located in the body (1); at least one induction coil (4) located on the carrier plate (3); at least one electronic board (2) for controlling operation of the induction coil (4); and at least one upper surface (5) located on the induction coil (4).

The heating device (C) further comprises at least a first connection member (3a) located on the carrier plate (3), which has at least one vertical portion extending upward from the carrier plate (3), preferably in a vertical manner, and at least one horizontal portion located on the side of the vertical portion distal to the carrier plate (3) and preferably extending parallel to the carrier plate; at least a second connection member (3b) extending upward from the carrier plate (3), preferably in a vertical manner; at least one base plate (6), preferably in the form of a fedora, which is located in the lower part of the induction coil (4); at least a first slot (6a) in the base plate (6) suitable for accommodating the vertical portion of the first connection member (3a); and at least a second slot (6b) in the base plate (6) suitable for accommodating the second connection member (3b).

[0017] In an exemplary embodiment of the invention, while manufacturing the heating device (C), which is exemplified as a stove, the induction coil (4) is connected to the carrier plate (3) by inserting the first connection member (3a) and the second connection member (3b) into the first slot (6a) and the second slot (6b). For this process, first of all, the induction coil (4) is positioned on the carrier plate (3) at an angle such that the first slot (6a) faces the vertical portion of the first connection member (3a) and the first slot (6a) remains below (as shown in Figure 3). Then, by moving the induction coil (4) to approach the first connection member (3a), the vertical portion of the first connection member (3a) is placed in the first slot (6a). Afterwards, the other upper part of the induction coil (4) is released to move downwards so that it engages the second connection member (3b) of the second slot (6b). In this position, a part of the base plate (6) around the first slot (6a) remains between the horizontal portion of the first connection member (3a) and the carrier plate (3). Thus, the movement of the induction coil (4) in the vertical axis is limited. Here, also, the movement of the induction coil (4) in horizontal axes is prevented by the placement of the vertical portion of the first connection member (3a) in the first slot (6a) and the second connection member (3b) in the second slot (6b). Thus, it is ensured that the induction coil (4) is connected to the carrier plate (3) in a practical and reliable manner.

[0018] In a preferred embodiment of the invention, there is a 180° angle between the first slot (6a) and the second slot (6b). Thus, when the induction coil (4) is positioned at an angle, with the first slot (6a) facing downwards, during the assembly of the heating device (C), the second slot (6b) faces upwards. Therefore, it is ensured that the second slot (6b) is easily fitted on the second connection member (3b).

[0019] In another preferred embodiment of the invention, the first connection member (3a) is in the form of an inverted "L". In an alternative embodiment, the first connection member (3a) is in the form of a "T".

[0020] In another preferred embodiment of the invention, the first connection member (3a) and/or the second connection member (3b) are in a monolithic structure with

the carrier plate (3). In this embodiment, the first connection member (3a) and/or the second connection member (3b) may be formed by cutting the carrier plate (3). Yet in an alternative embodiment, the first connection member (3a) and/or the second connection member (3b) are in the form of external parts connected to the carrier plate (3). In this embodiment, the heating device (C) comprises at least one connection mechanism for connecting the first connection member (3a) and/or the second connection member (3b) to the carrier plate (3). Said connection mechanism may comprise welding or adhering.

[0021] In another preferred embodiment of the invention, the electronic board (2) comprises at least one switching element (2a). Said switching element (2a) is connected with at least one induction coil (4) and controls the operation of the induction coil (4) to which it is connected. The electronic board (2) also comprises at least one cooling block (2b) in the form of a heat sink.

[0022] In the heating device (C) according to the present invention, the induction coil (4) is connected to the carrier plate (3) by inserting the first connection member (3a) and the second connection member (3b) located on the carrier plate (3) into the first slot (6a) and the second slot (6b) located on the base plate (6) of the induction coil (4). Therefore, the connection process is carried out in an easy and reliable manner.

Claims

1. A heating device (C) comprising at least one body (1); at least one carrier plate (3) located in the body (1); at least one induction coil (4) located on the carrier plate (3); at least one electronic board (2) for controlling operation of the induction coil (4); and at least one upper surface (5) located on the induction coil (4), **characterized by** comprising
 - at least a first connection member (3a) located on the carrier plate (3), which has at least one vertical portion extending upward from the carrier plate (3) and at least one horizontal portion located on the side of the vertical portion distal to the carrier plate (3), wherein said first connection member (3a) is in a monolithic structure with the carrier plate (3);
 - at least a second connection member (3b) extending upward from the carrier plate (3), wherein said second connection member (3a) is in a monolithic structure with the carrier plate (3);
 - at least one base plate (6) located in the lower part of the induction coil (4);
 - at least a first slot (6a) in the base plate (6) suitable for accommodating the vertical portion of the first connection member (3a); and
 - at least a second slot (6b) in the base plate (6) suitable for accommodating the second connec-

tion member (3b).

2. A heating device (C) according to claim 1, **characterized in that** the angle between the first slot (6a) and the second slot (6b) is 180°.
3. A heating device (C) according to any of the preceding claims, **characterized in that** the first connection member (3a) is in the form of an inverted "L".
4. A heating device (C) according to any of the claims 1 to 2, **characterized in that** the first connection member (3a) is in the form of a "T".
5. A heating device (C) according to any of the preceding claims, **characterized in that** the electronic board (2) comprises at least one switching element (2a).
6. A heating device (C) according to any of the preceding claims, **characterized in that** the electronic board (2) comprises at least one cooling block (2b).

25 Patentansprüche

1. Heizvorrichtung (C) mit wenigstens einem Grundkörper (1), wenigstens einer Tragplatte (3), die in dem Grundkörper (1) angeordnet ist, wenigstens einer Induktionsspule (4), die sich auf der Trägerplatte (3) befindet, wenigstens einer Elektronikkarte (2) zum Steuern des Betriebes der Induktionsspule (4), und wenigstens einer oberen Oberfläche (5), die sich auf der Induktionsspule (4) befindet, **dadurch gekennzeichnet, dass** die Heizvorrichtung aufweist
 - wenigstens ein erstes, auf der Trägerplatte (3) befindliches Verbindungsteil (3a), das wenigstens einen vertikalen Bereich, der von der Trägerplatte (3) nach oben verläuft, und wenigstens einen horizontalen Bereich hat, der sich an derjenigen Seite des vertikalen Bereichs befindet, die entfernt von der Trägerplatte (3) ist, wobei das erste Verbindungsteil (3a) in einer mit der Trägerplatte (3) monolithischen Struktur ist,
 - wenigstens ein zweites Verbindungsteil (3b), das von der Trägerplatte (3) nach oben verläuft, wobei das zweite Verbindungsteil (3b) in einer monolithischen Struktur mit der Trägerplatte (3) ist,
 - wenigstens eine Basisplatte (6), die sich in dem unteren Teil der Induktionsspule (4) befindet,
 - wenigstens einen ersten Schlitz (6a) in der Basisplatte (6), der zur Aufnahme des vertikalen Bereichs des ersten Verbindungsteils (3a) geeignet ist, und
 - wenigstens einen zweiten Schlitz (6b) in der

Basisplatte (6), der zur Aufnahme des zweiten Verbindungsteils (3b) geeignet ist.

2. Heizvorrichtung (C) nach Anspruch 1, **dadurch gekennzeichnet, dass** der Winkel zwischen dem ersten Schlitz (6a) und dem zweiten Schlitz (6b) 180° beträgt. 5
3. Heizvorrichtung (C) nach einem der vorhergehenden Ansprüche, **dadurch gekennzeichnet, dass** das erste Verbindungsteil (3a) die Form eines umgekehrten "L" hat. 10
4. Heizvorrichtung (C) nach einem der Ansprüche 1 bis 2, **dadurch gekennzeichnet, dass** das erste Verbindungsteil (3a) die Form eines "T" hat. 15
5. Heizvorrichtung (C) nach einem der vorhergehenden Ansprüche, **dadurch gekennzeichnet, dass** die Elektronikarte (2) wenigstens ein Schaltelement (2a) aufweist. 20
6. Heizvorrichtung (C) nach einem der vorhergehenden Ansprüche, **dadurch gekennzeichnet, dass** die Elektronikarte (2) wenigstens einen Kühlblock (2b) aufweist. 25

Revendications 30

1. Dispositif de chauffage (C) comprenant au moins un corps (1) ; au moins une plaque de support (3) située dans le corps (1) ; au moins une bobine d'induction (4) située sur la plaque de support (3) ; au moins une carte électronique (2) pour contrôler le fonctionnement de la bobine d'induction (4) ; et au moins une surface supérieure (5) située sur la bobine d'induction (4), **caractérisé en ce qu'elle** comprend 35
 - au moins un premier élément de connexion (3a) situé sur la plaque de support (3), qui présente au moins une partie verticale s'étendant vers le haut à partir de la plaque de support (3) et au moins une partie horizontale située sur le côté de la partie verticale distale par rapport à la plaque de support (3), dans lequel ledit premier élément de connexion (3a) est dans une structure monolithique avec la plaque de support (3) ; 40
 - au moins un deuxième élément de connexion (3b) s'étendant vers le haut à partir de la plaque de support (3), dans lequel ledit deuxième élément de connexion (3a) est dans une structure monolithique avec la plaque de support (3) ; 45
 - au moins une plaque de base (6) située dans la partie inférieure de la bobine d'induction (4) ; 50
 - au moins une première fente (6a) dans la plaque de base (6) apte à recevoir la partie 55

verticale du premier élément de connexion (3a) ; et

- au moins une deuxième fente (6b) dans la plaque de base (6) apte à recevoir le deuxième élément de connexion (3b).

2. Dispositif de chauffage (C) selon la revendication 1, **caractérisé en ce que** l'angle entre la première fente (6a) et la deuxième fente (6b) est de 180°. 5
3. Dispositif de chauffage (C) selon l'une quelconque des revendications précédentes, **caractérisé en ce que** le premier élément de connexion (3a) se présente sous la forme d'un « L » inversé. 10
4. Dispositif de chauffage (C) selon l'une quelconque des revendications 1 à 2, **caractérisé en ce que** le premier élément de connexion (3a) a la forme d'un « T ». 15
5. Dispositif de chauffage (C) selon l'une quelconque des revendications précédentes, **caractérisé en ce que** la carte électronique (2) comprend au moins un élément de commutation (2a). 20
6. Dispositif de chauffage (C) selon l'une quelconque des revendications précédentes, **caractérisé en ce que** la carte électronique (2) comprend au moins un bloc de refroidissement (2b). 25

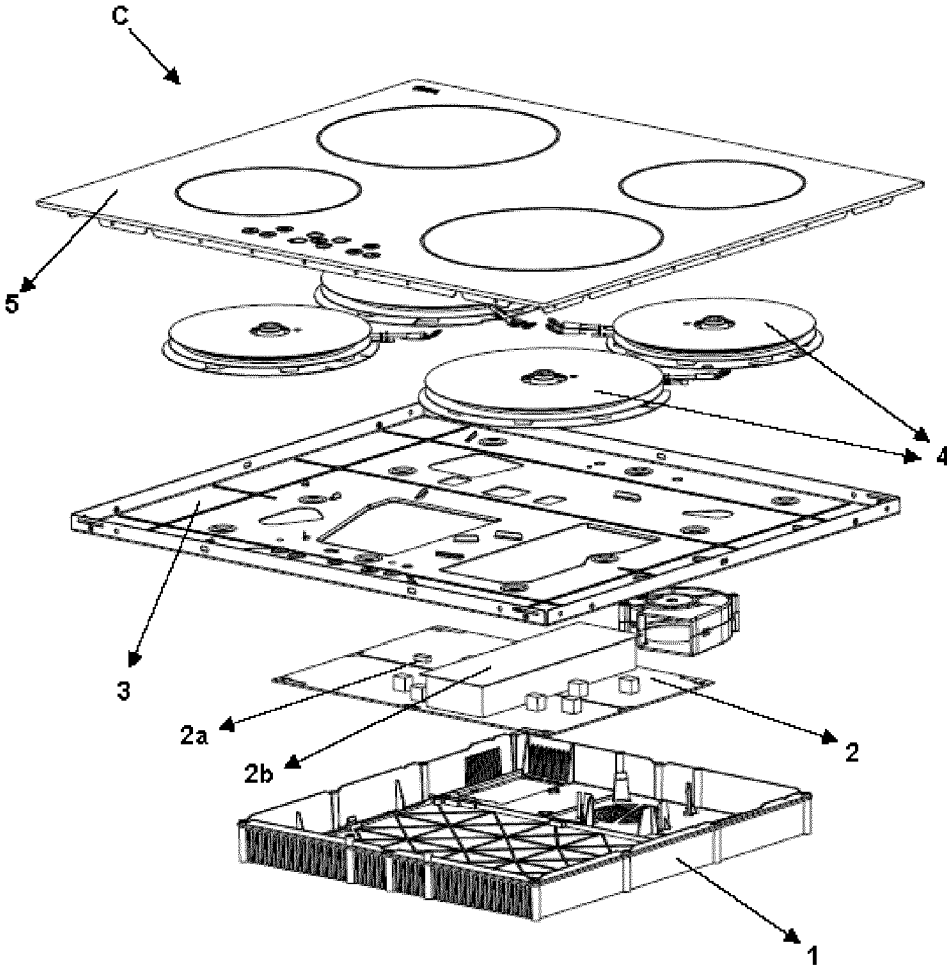

Figure - 1

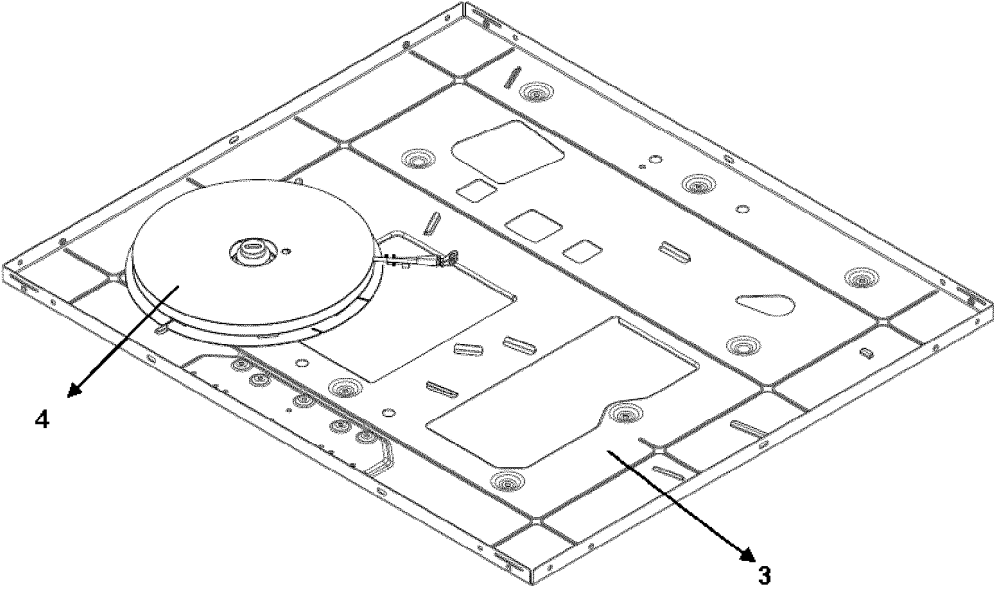

Figure - 2

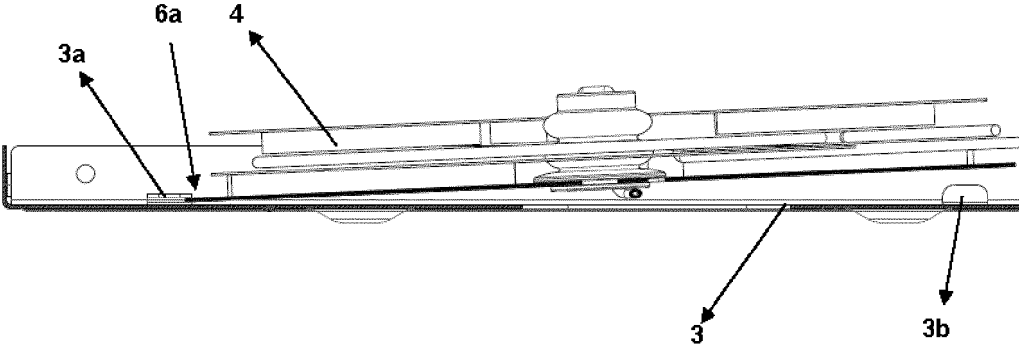

Figure - 3

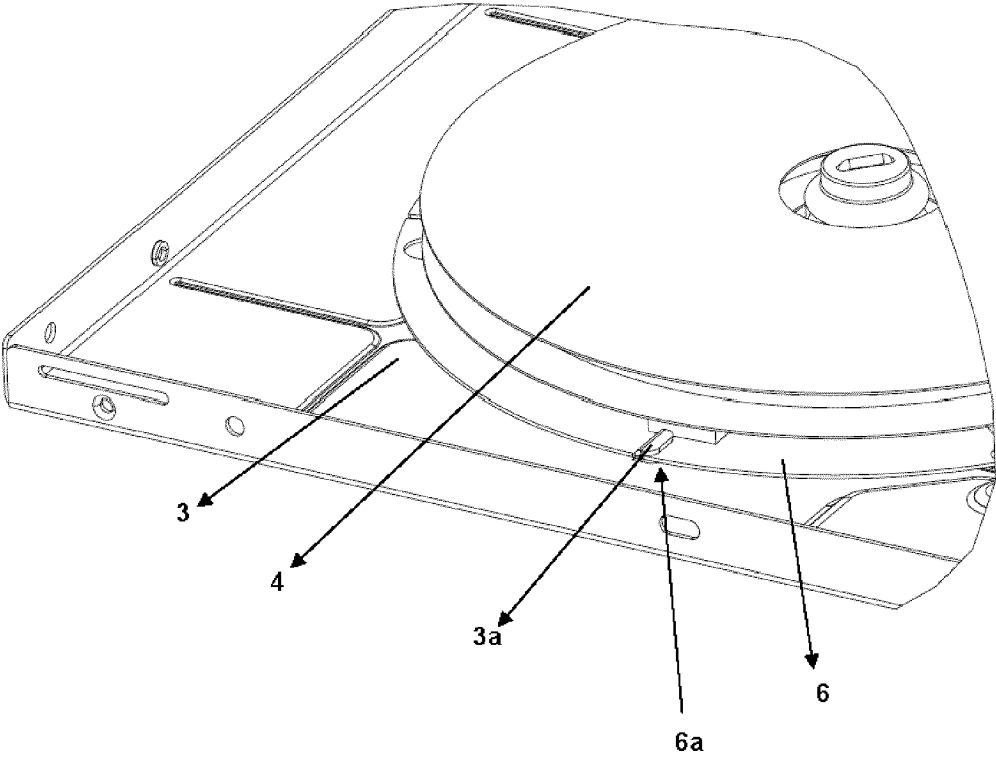

Figure - 4

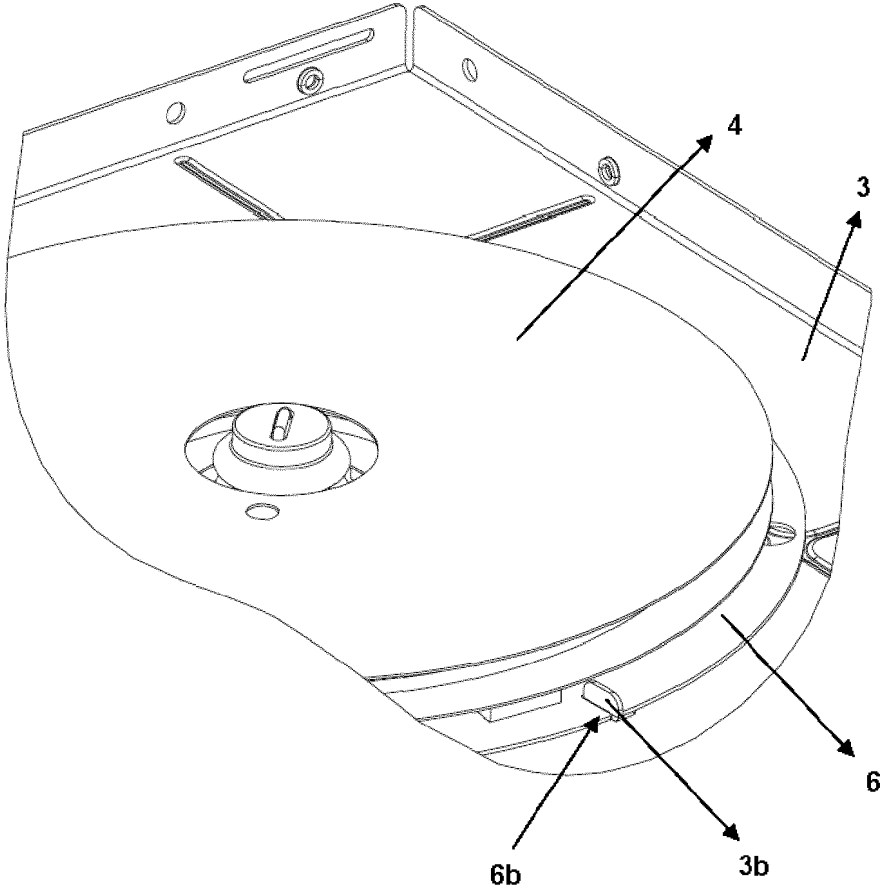

Figure - 5

REFERENCES CITED IN THE DESCRIPTION

This list of references cited by the applicant is for the reader's convenience only. It does not form part of the European patent document. Even though great care has been taken in compiling the references, errors or omissions cannot be excluded and the EPO disclaims all liability in this regard.

Patent documents cited in the description

- EP 2775785 A1 [0007]
- EP 3675600 A1 [0008]
- US 2016057815 A1 [0009]
- WO 2015049602 A1 [0010]