



US 20070169774A1

(19) **United States**

(12) **Patent Application Publication**
Johnson et al.

(10) **Pub. No.: US 2007/0169774 A1**

(43) **Pub. Date: Jul. 26, 2007**

(54) **AEROSOL ENHANCEMENT DEVICE**

tinuation-in-part of application No. 09/610,801, filed on Jul. 6, 2000, now Pat. No. 6,363,932.

(75) Inventors: **Robert Johnson**, Yucca Valley, CA (US); **Robert DuBose**, Oakland, OR (US)

Publication Classification

Correspondence Address:
STOUT, UXA, BUYAN & MULLINS LLP
4 VENTURE, SUITE 300
IRVINE, CA 92618 (US)

(51) **Int. Cl.**
A61M 11/00 (2006.01)
(52) **U.S. Cl.** **128/200.14**

(73) Assignee: **Clinical Technologies, Inc.**, Broadview, OH

(57) **ABSTRACT**

(21) Appl. No.: **11/726,967**

An aerosol medication delivery apparatus includes a fixed volume holding chamber which is constructed to allow for a uniformly mixed, concentrated bolus of medicated aerosol to be delivered with each breath. The device further includes a universal inlet, so that any standard small volume nebulizer, as well as any standard metered dose inhaler (MDI), may be utilized therewith. Also filtration can be added to address contaminated patient air and aerosol. A one-way valve is positioned in the patient mouthpiece, to help control the loss of aerosol, and thereby reduce waste.

(22) Filed: **Mar. 23, 2007**

Related U.S. Application Data

(60) Division of application No. 09/855,403, filed on May 15, 2001, now Pat. No. 7,204,245, which is a con-

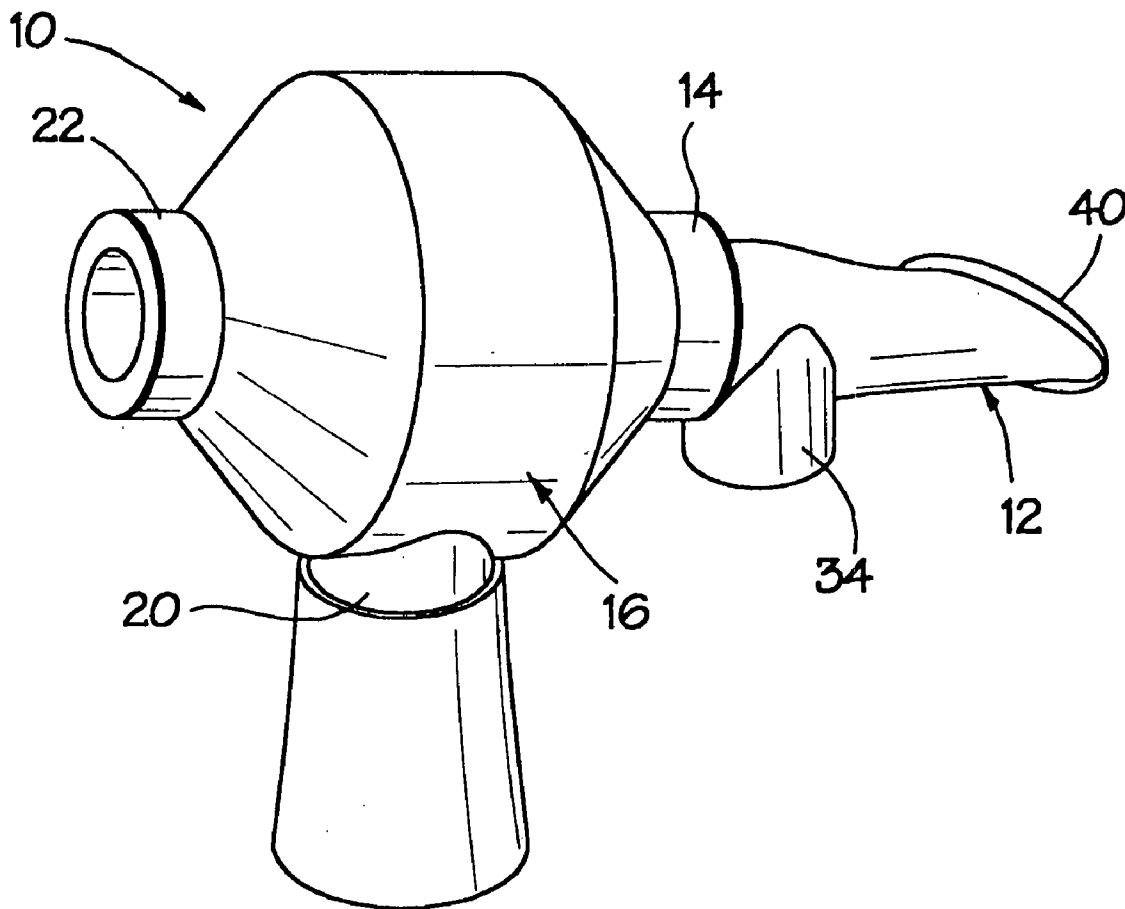

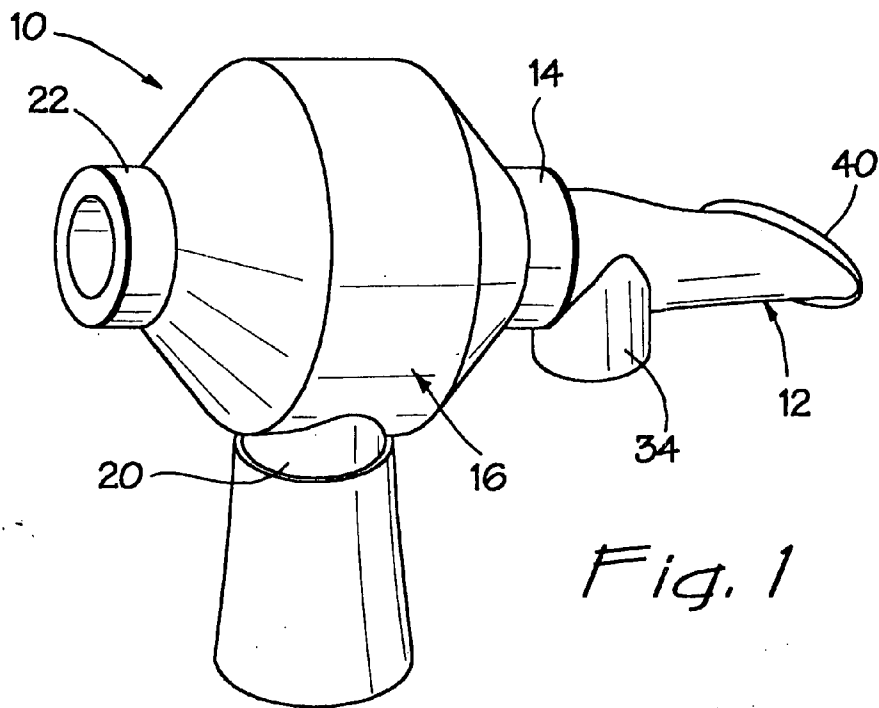

Fig. 1

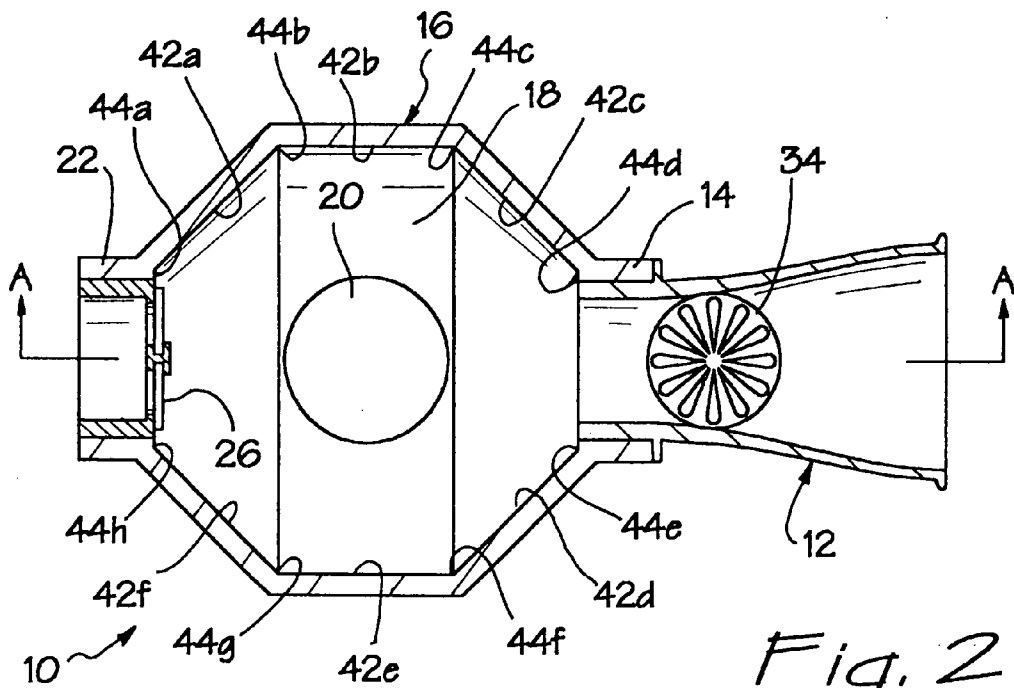

Fig. 2

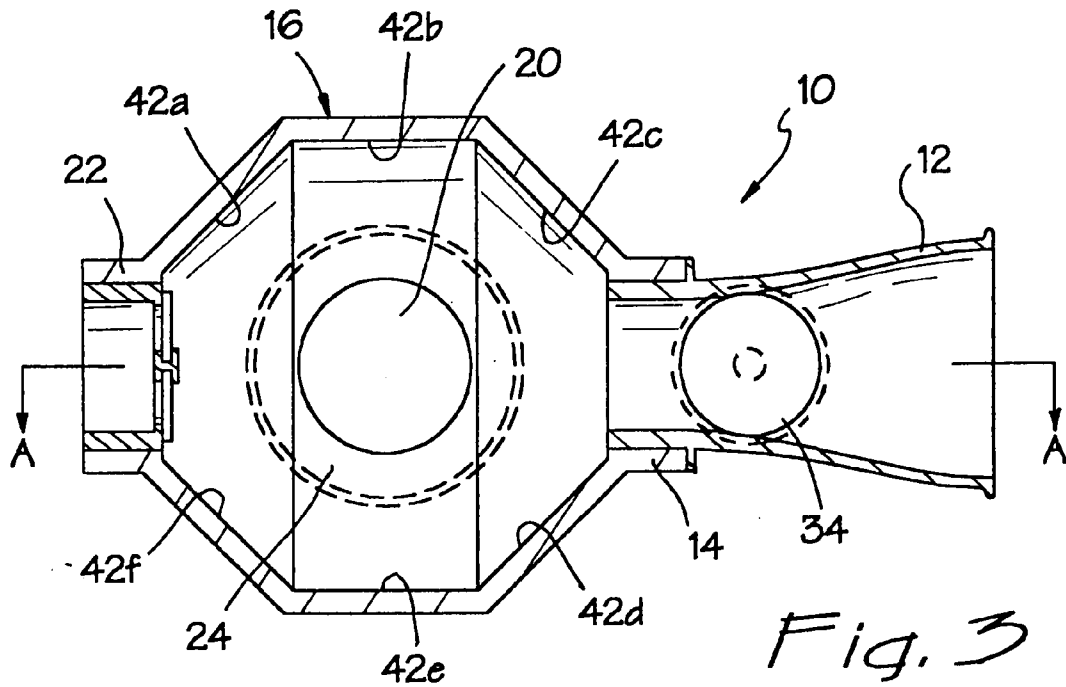

Fig. 3

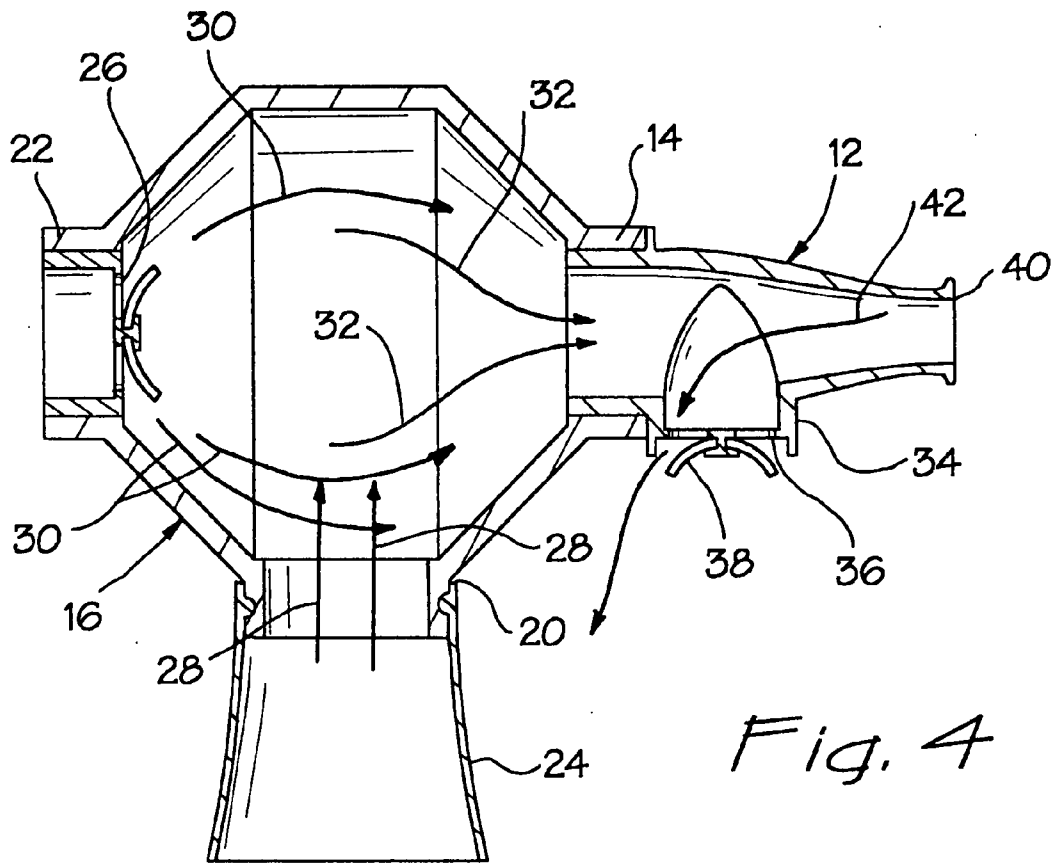

Fig. 4

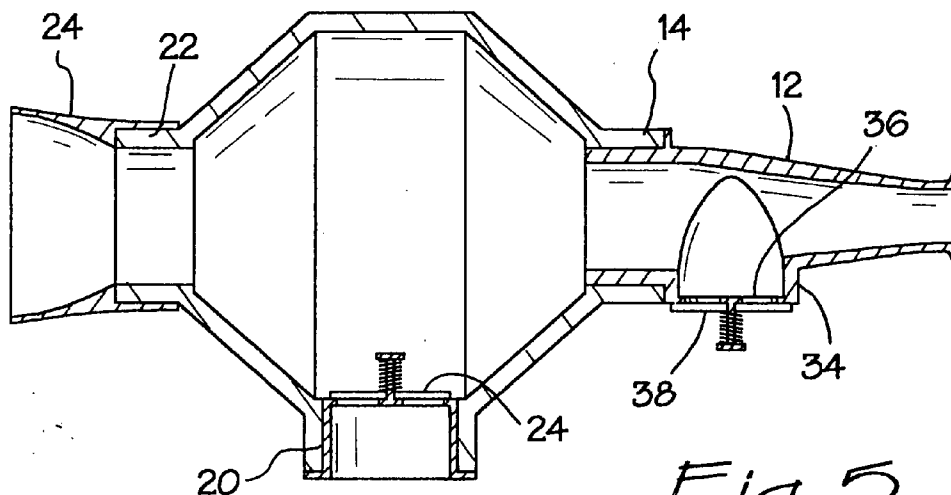

Fig. 5

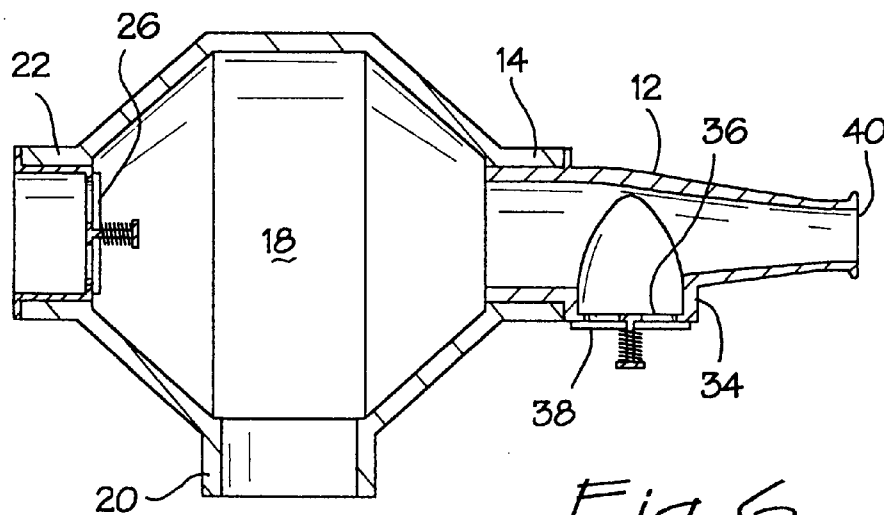

Fig. 6

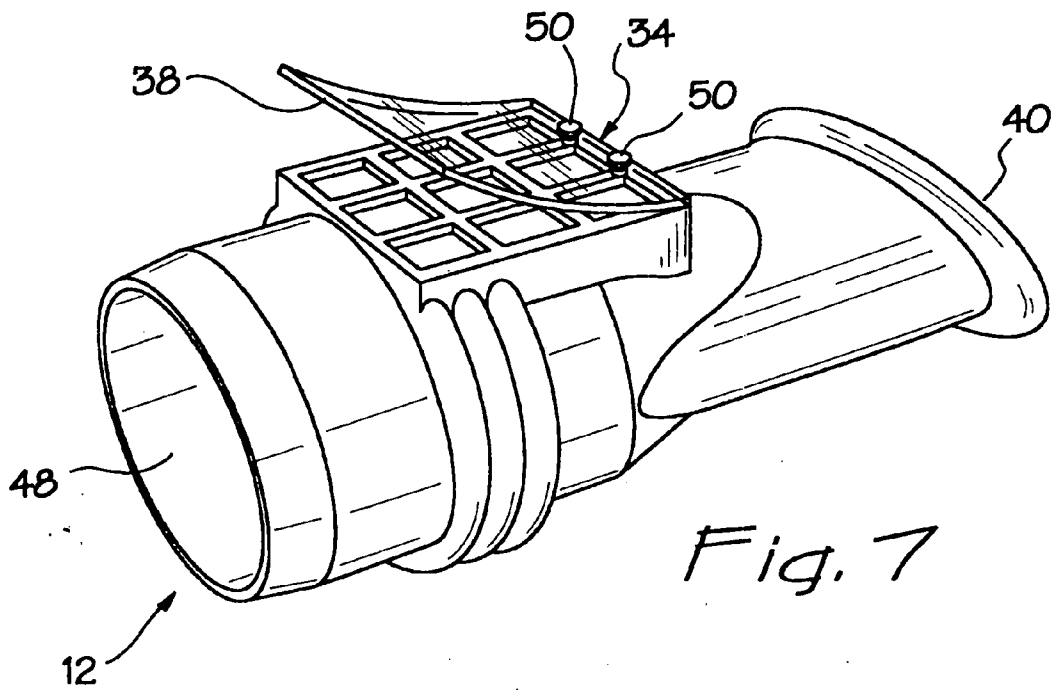

Fig. 7

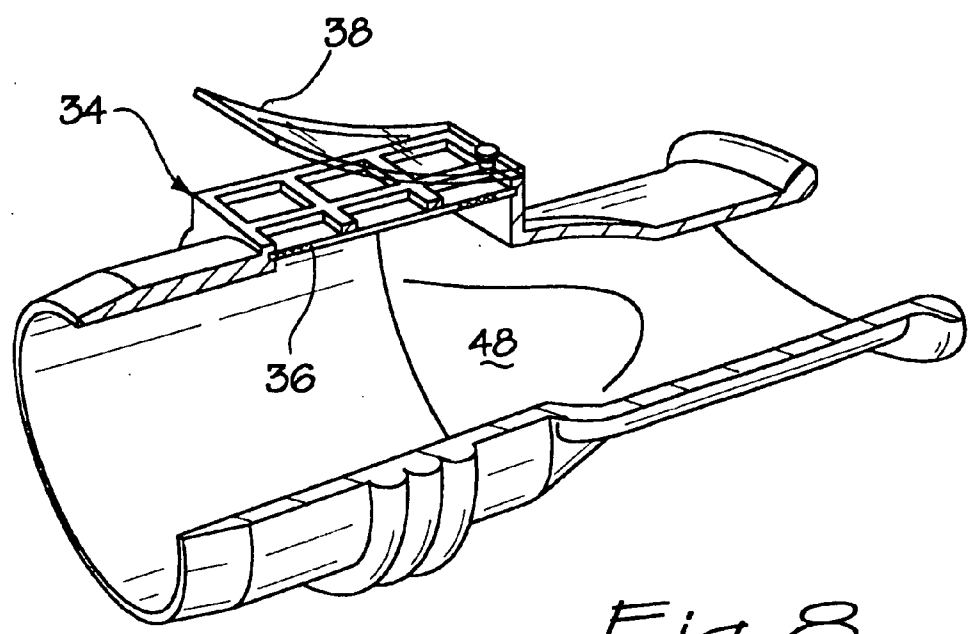

Fig. 8

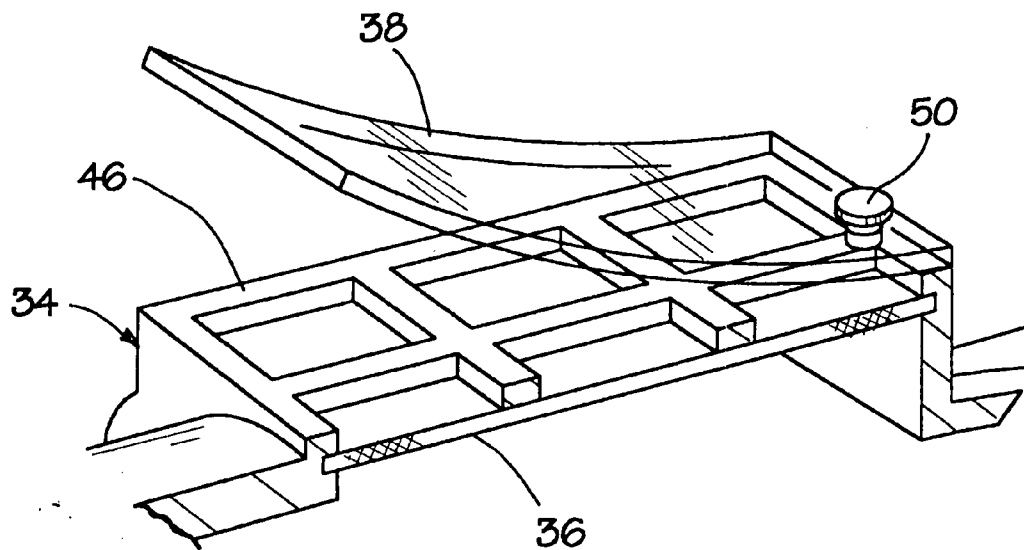

Fig. 9

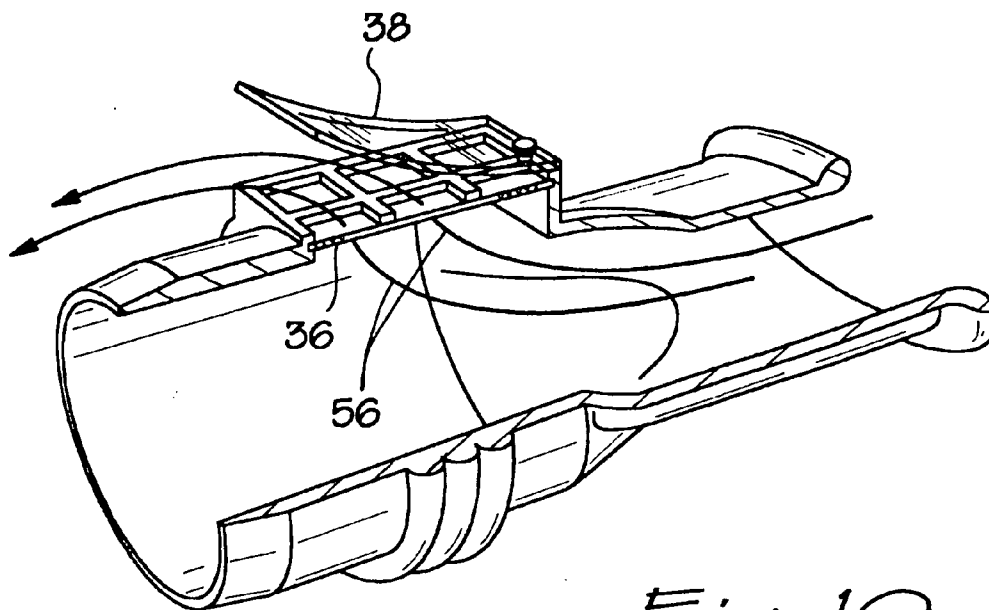

Fig. 10

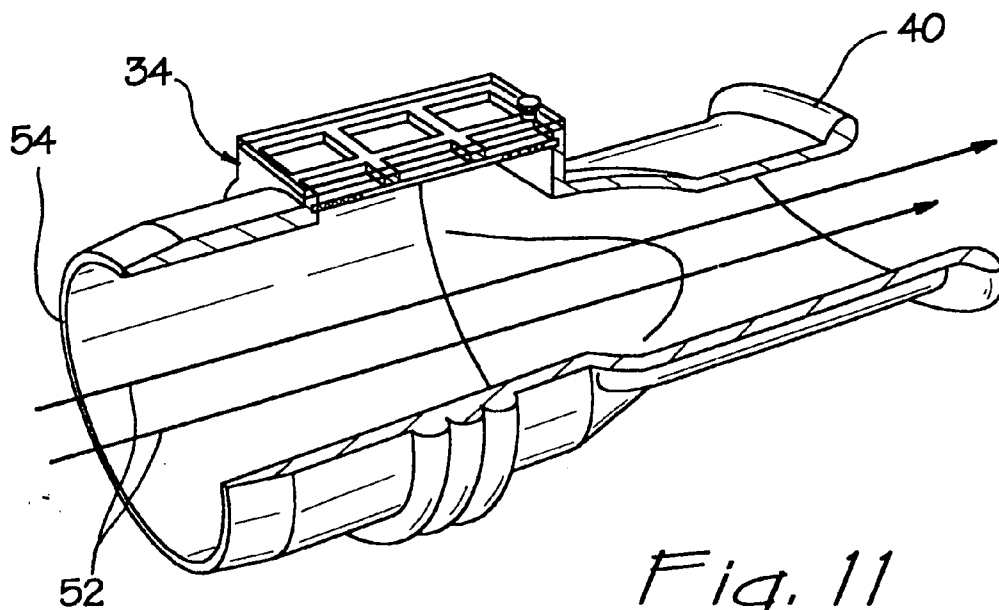

Fig. 11

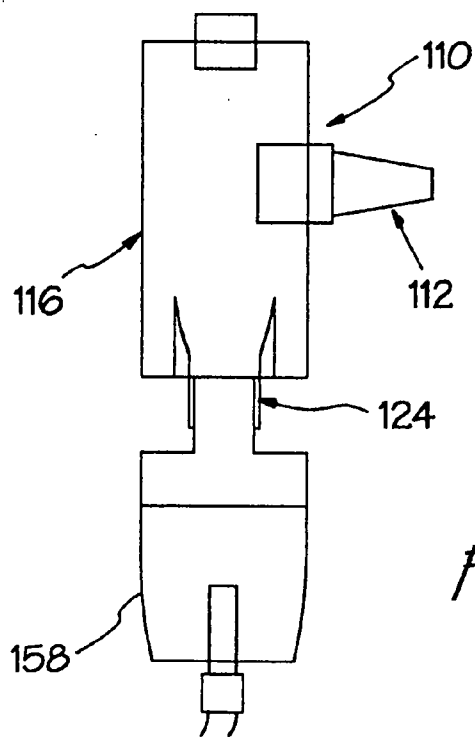

Fig. 12

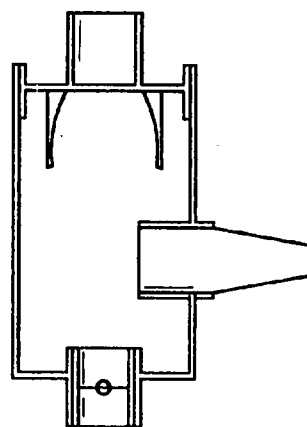
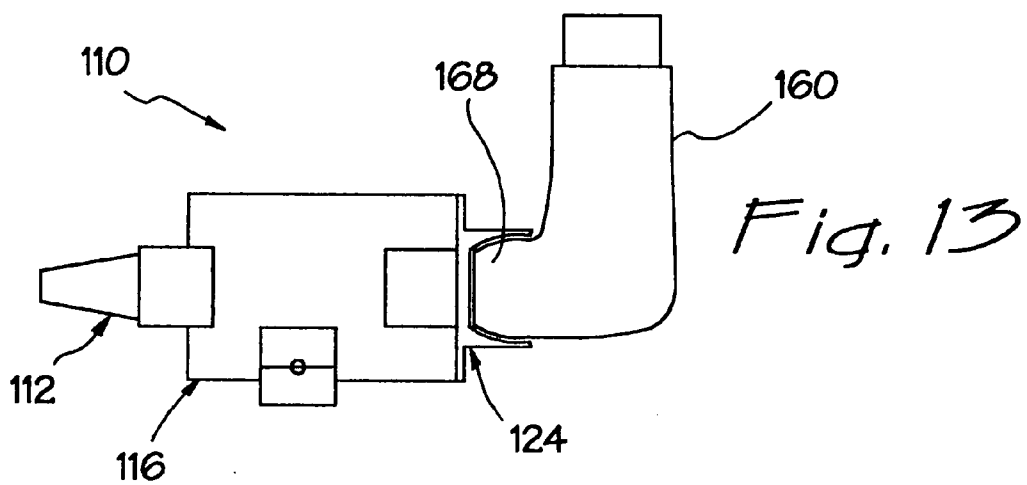

Fig. 14

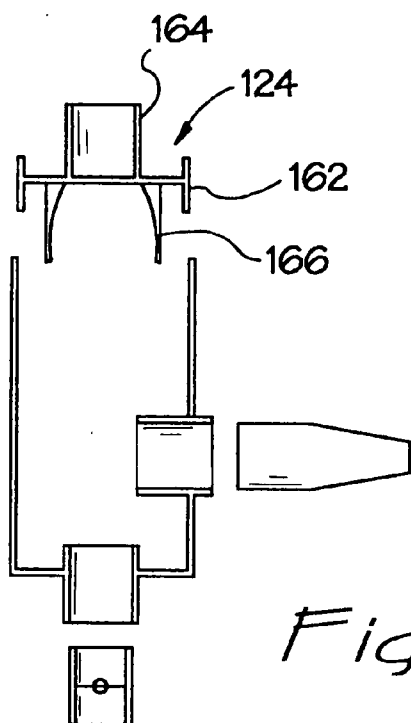

Fig. 15

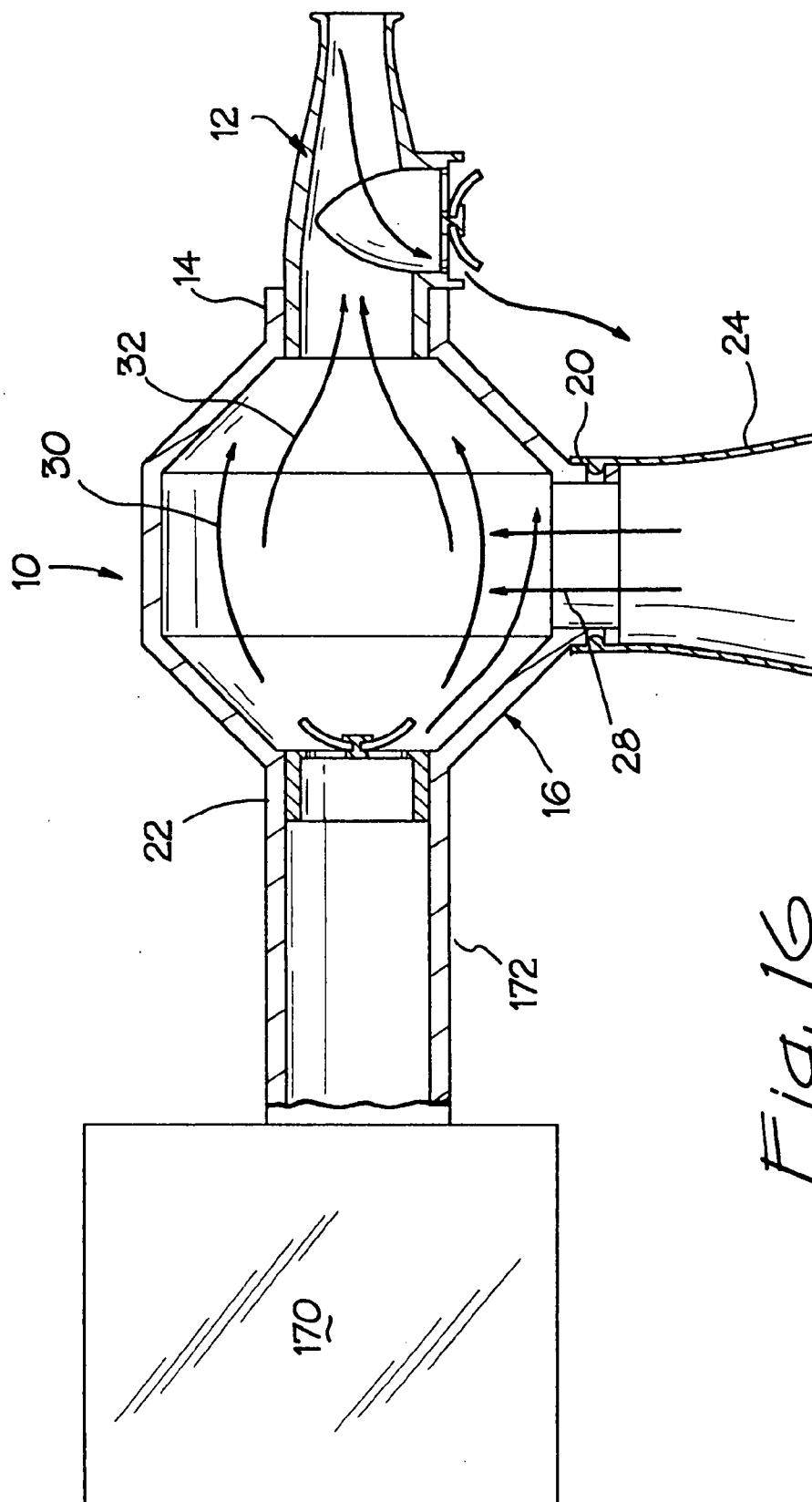

Fig. 16

AEROSOL ENHANCEMENT DEVICE

[0001] This application is a continuation-in-part of application Ser. No. 09/610,801, also entitled Aerosol Enhancement Device, filed on Jul. 6, 2000, which is commonly assigned and herein expressly incorporated by reference.

BACKGROUND OF THE INVENTION

[0002] This invention relates generally to an improved aerosol inhalation device, and more particularly to an aerosol enhancement device which is usable in combination with both a nebulizer and a metered dose inhaler.

[0003] Aerosol inhalation devices, for the purpose of delivering medication, entrained in an aerosol spray, to a patient using inhalation therapy, as an alternative to oral medications such as capsules or pills, or to injected medications, are well known in the art. For example, U.S. Pat. No. 4,210,155 to Grimes is representative of the prior art. In the Grimes patent there is disclosed a fixed volume mist accumulation chamber for use in combination with a nebulizer and a tee connection of an inhalation conduit for accumulating medicated mist and facilitating its delivery to a patient.

[0004] However, the Grimes device, as is typical for prior art devices, is plagued with problems typical of such devices. These problems include, for example, non-uniform concentrations of medication, resulting in difficulties in regulating patient dosage, and significant waste of medication. Additionally, the Grimes device is relatively complex, so that it is expensive to manufacture and difficult to use.

[0005] Many other such devices are available which do not include a mixing chamber. In other words, the nebulizer is attached directly to the aforementioned tee connection. Of course, such devices are even less suited to satisfactory regulation of the medication being delivered to the patient than the Grimes device, because there is substantially no ability to uniformly mix the medication with entrained fluid, such as air, before delivery to the mouthpiece on which the patient is inhaling.

[0006] In addition to nebulizers, metered dose inhalers (MDI) are also available for delivering a medicated aerosol to a patient. These MDI devices differ from nebulizers primarily in that a propellant is used to deliver the medication.

[0007] It would be advantageous to have an aerosol medication delivery device which included a mixing chamber between the medication delivery apparatus and the mouthpiece, wherein the medication could be uniformly mixed with entrained air in an improved manner over that achieved by the Grimes patent apparatus. It would also be beneficial for such a device to be simple to manufacture and assemble, and easy to use. Finally, if such a device could be made universally adaptable for use with any known nebulizer on the market, as well as with MDI's, this would be a great advance in the art.

SUMMARY OF THE INVENTION

[0008] The present invention provides an aerosol medication delivery apparatus which incorporates the aforementioned advantages. The inventive device includes a fixed volume holding chamber which is constructed to allow for

a uniformly mixed, concentrated bolus of medicated aerosol to be delivered with each breath. The device further includes a universal inlet, so that any standard small volume nebulizer, as well as any standard MDI, may be utilized therewith. Also filtration can be added to address contaminated patient air and aerosol. A one-way valve is positioned in the patient mouthpiece, to help control the loss of aerosol, and thereby reduce waste.

[0009] More particularly, an aerosol enhancement device is provided which comprises a mouthpiece and a spacer member fluidly attached to the mouthpiece. The spacer member has interior walls which define an interior volume, which comprises a mixing chamber. An inlet port is disposed in the spacer member for receiving a medicated aerosol from an exterior source into the mixing chamber. An air inlet port is disposed in the spacer member, as well, for receiving air into the air passage. Advantageously, the mixing chamber is generally octagonal in configuration, which the inventors have found assists in collecting and re-using excess medication .

[0010] In another aspect of the invention, an aerosol enhancement device is provided which comprises a mouthpiece and a spacer member fluidly attached to the mouthpiece. The spacer member is fluidly attached to the mouthpiece via a mouthpiece port, and has an outer body which defines an interior volume. An inlet port is disposed in the spacer member for receiving a medicated aerosol from an exterior source into the interior volume. Advantageously, an adapter is associated with the medicated aerosol inlet port. The inventive adapter comprises a universal fitting which is capable of attaching the spacer member to either a nebulizer or a metered dose inhaler (MDI).

[0011] Preferably, the inventive adapter is reversible, being disposable in a first orientation for attachment of the spacer member to a nebulizer, and being disposable in a second orientation for attachment of the spacer member to an MDI. In its preferred configuration, the universal adapter comprises a first rigid connector end and a second flexible connector end, the first rigid connector end being adapted for attachment to a nebulizer and the second flexible connector end being adapted for attachment to an MDI. The adapter preferably further comprises a flange portion for engaging the adapter with the spacer member.

[0012] In still another aspect of the invention, an aerosol enhancement device is provided which comprises a mouthpiece having a first port for fluid communication with a patient's mouth, a second port which is open to atmosphere, and a third port, wherein an airway fluidly communicates with each of the first, second, and third ports. A medication dispenser is attached to the third port and a one-way flap valve is disposed in the second port. The one-way flap valve advantageously includes a valve seat for receiving the flap valve and for preventing the flap valve from entering the airway.

[0013] In yet another aspect of the invention, a spacer member is provided which is usable with a mouthpiece, for dispensing medicated aerosol to a patient. The inventive spacer member comprises an outer body which defines an interior volume or mixing chamber. An inlet port is disposed in the spacer member for receiving a medicated aerosol from an exterior source into the mixing chamber. An air inlet port is also disposed in the spacer member for receiving air into

the mixing chamber. An outlet port is provided for dispensing a mixture of the medicated aerosol and inlet air from the mixing chamber into the mouthpiece. Advantageously, a one-way valve is disposed in the air inlet port, for ensuring that there is no loss of medicated aerosol from the mixing chamber.

[0014] The invention, together with additional features and advantages thereof, may best be understood by reference to the following description taken in conjunction with the accompanying illustrative drawing.

BRIEF DESCRIPTION OF THE DRAWINGS

[0015] FIG. 1 is a perspective view of an aerosol enhancement device constructed in accordance with the principles of the present invention;

[0016] FIG. 2 is a cross-sectional view, taken from the top, of the device shown in FIG. 1;

[0017] FIG. 3 is a cross-sectional view, taken from the bottom, of the device shown in FIG. 1;

[0018] FIG. 4 is a cross-sectional view taken along lines A-A of FIGS. 2 and 3;

[0019] FIG. 5 is a cross-sectional view taken along lines A-A of FIGS. 2 and 3, showing the embodiment of FIG. 1 when it is set-up to function in conjunction with a metered dose inhaler (MDI);

[0020] FIG. 6 is a cross-sectional view taken along lines A-A of FIGS. 2 and 3, showing the embodiment of FIG. 1 when it is set-up to function in conjunction with a nebulizer;

[0021] FIG. 7 is a perspective view of a presently preferred embodiment of the mouthpiece portion of the aerosol enhancement device illustrated in FIGS. 1-6;

[0022] FIG. 8 is a perspective cut-away view of the mouthpiece portion shown in FIG. 7;

[0023] FIG. 9 is an enlarged perspective view of the filter and valve portions of the mouthpiece portion shown in FIGS. 7 and 8;

[0024] FIG. 10 is a view similar to FIG. 8, illustrating the airflow pattern through the mouthpiece portion during exhalation by a patient using the device;

[0025] FIG. 11 is a view similar to FIGS. 8 and 10 illustrating the airflow pattern through the mouthpiece portion during inhalation by a patient using the device;

[0026] FIG. 12 is a schematic view of an alternative embodiment of the aerosol enhancement device of the present invention, wherein the aerosol enhancement device is configured for use with a nebulizer;

[0027] FIG. 13 is a schematic view of the embodiment of FIG. 12, wherein the aerosol enhancement device is configured for use with an MDI;

[0028] FIG. 14 is a schematic view illustrating, in somewhat greater detail, the structural features of the embodiment shown in FIGS. 12 and 13;

[0029] FIG. 15 is an exploded schematic view of the embodiment shown in FIG. 14; and

[0030] FIG. 16 is a cross-sectional view of an embodiment of the invention, wherein the aerosol enhancement device is disposed in-line in an assisted breathing ventilator system.

DESCRIPTION OF THE PREFERRED EMBODIMENT

[0031] Referring now more particularly to FIGS. 1-6, there is shown a first embodiment of the inventive aerosol enhancement device 10. The device 10 comprises a mouthpiece 12 which is fluidly attached to a mouthpiece port 14 on a tower or spacer body 16. The spacer body 16 comprises an interior volume or mixing chamber 18 and two additional inlet ports 20 and 22, which communicate with the mixing chamber 18. In the illustrated embodiment, the ports 14 and 22 are disposed on opposing ends of the spacer body 16, with the port 20 disposed between the ports 14 and 22, on the bottom of the body 16 and at a transverse orientation with respect to the ports 14 and 22.

[0032] As shown particularly in FIGS. 5 and 6, the aerosol enhancement device 10 may be configured for use with a metered dose inhaler (MDI), as shown in FIG. 5, or a nebulizer, as shown in FIG. 6. Traditionally, an MDI is positioned "in-line" with the patient's mouth, so that the delivered medication flows directly through the chamber 18 in a straight line to the mouthpiece 12, and the air entering through the inlet port 20 becomes entrained in the flow of medication. Thus, in FIG. 5, the MDI (not shown) is connected to the inlet port 22, preferably using a flexible, universal boot 24. Additionally, though not required for an MDI, in the illustrated embodiment a stem valve (check valve) 26 is disposed in the other inlet port 20.

[0033] In FIG. 6, on the other hand, when a nebulizer (not shown) is utilized in conjunction with the aerosol enhancement device 10, it is preferably connected to the bottom inlet port 20, and the stem valve 26 is re-positioned in the other inlet port 22. The flexible universal boot 24 may be used to assist in connecting the nebulizer to the inlet port 20, as well, as is discussed more particularly in conjunction with the embodiments shown in FIGS. 12-15, and is particularly useful for accommodating odd-sized nebulizer stems. Typical nebulizer applications are adapted so that the medication becomes entrained in the airflow, as opposed to MDI applications wherein the air preferably is arranged to become entrained in the flow of medication, although there is no requirement that the arrangements be such.

[0034] It should be noted that, although the device 10 has been configured as shown in FIGS. 5 and 6, respectively, for the MDI and nebulizer applications, the illustrated configurations, although preferred, are not required. Each of the ports 14, 20, and 22 are preferably constructed to be substantially identical and interchangeable, so that they may each, as desired, accommodate any one of the mouthpiece, valve, and MDI or nebulizer, in any combination.

[0035] As shown in FIG. 4, for example, wherein the device 10, having a slightly modified construction as compared with the construction shown in FIG. 6, is configured for attachment to a nebulizer (not shown). The lower inlet port 20 supplies a medicated aerosol, as shown by arrows 28, into the mixing chamber 18, which functions as a mixing zone for mixing the incoming medication with incoming air from the inlet port 22, represented by arrows 30.

[0036] The purpose for the holding or mixing chamber 18 is to thoroughly mix the incoming medication and air together, which occurs as the two components flow together, in turbulent fashion, through the mixing chamber 18, becoming mixed together and exiting the chamber through port 14, as shown by arrows 32. Once thoroughly mixed, the medicated mixture flows into the mouthpiece 12 for inhalation by a patient. The mouthpiece 12 includes an exhaust port 34 in a sidewall thereof, as shown in the drawings, which preferably includes an optional filter 36, and a one-way valve 38, which may also be a stem valve of the same type as valve 26. The filter 36, though optional, has been found to be useful in dealing with circumstances involving contaminated or infectious patient air and aerosol, to minimize the spread of infection. During inhalation, the one-way valve remains tightly closed, so that the medicated mixture flows through the mouthpiece 12 and out of the proximal mouth port 40 into the patient's mouth. Then, during exhalation, as shown by arrows 42, the airflow from the patient's mouth, back through the mouthpiece 12, exits the mouthpiece through the now-opened one-way valve 38.

[0037] A significant advantage the inventors have discovered is gained by use of a valved exhaust port 34, as opposed to an unvalved, open port, is that the valve helps to retain substantially greater quantities of medication in the device by confining medicated aerosol within the mixing chamber 18 and mouthpiece 12 during the critical inhalation phase.

[0038] Advantageously, the mixing chamber 18 in the preferred embodiments is constructed to be defined by interior walls which are arranged to result in a generally octagonal-shaped chamber when viewed in any plane. In other words, the interior wall defining the chamber 18 comprises a plurality of interior generally planar wall segments 42a, 42b, 42c, 42d, 42e, and 42f, for example, which together with the two segments comprising the ports 14 and 22, form the eight generally planar surfaces of the octagon when viewed in cross-section from either the top or the bottom side of the device, as shown in FIGS. 3 and 4, respectively. However, the number of wall segments defining the chamber is not particularly important. Any polygonal shape will suffice, because the key is to have a plurality of corners, or transition zones 44a, 44b, 44c, 44d, 44e, 44f, 44g, and 44h, for example, again as shown in FIGS. 2 and 3, between wall segments and/or ports. In this regard, having eight planar surfaces, as opposed to four, or six, produces substantially better results, as will be described below, with respect to the preservation of medication, because there will be more corners than in a fewer-sided polygon, and thus, greater reduction in wall surface area for a particular volume.

[0039] Of course, as is known, the mixing chamber 18 has a function of collecting aerosol distributed from either the nebulizer or MDI, and permitting it to become denser, for supplying an effective amount of medication to the patient. However, sometimes this results in an aerosol mixture which is overly dense, resulting in the wasting of valuable medication, either by over medicating the patient (which may be dangerous as well as wasteful) or by causing the excess medication to merely drain out of the mouthpiece through the exhaust port 34, into the surrounding environment. Advantageously, Applicants have found that the aforementioned corners or angled surfaces, in combination with the plurality of interior wall segments of the polygonal chamber,

minimize this waste of medication, by functioning to reduce the interior wall surface area required to define a desired interior volume, and to thereby promote the "raining out" or draining of excess medication within the aerosol mixture to the bottom of the chamber, where it can be collected and reused, before it flows into the mouthpiece.

[0040] FIGS. 7-11 illustrate a presently preferred embodiment of the mouthpiece 12 of the inventive aerosol enhancement device 10. In this embodiment, the exhaust port 34 comprises the filter 36, the one-way valve 38, which is in this case a flap valve, and a grid structure 46, which functions as a valve seat when the flap valve is in a closed position, for preventing the valve from descending into the mouthpiece airway 48. A pin or pins 50 are provided to secure one end of the flap valve 38 to the grid structure, in a pivotable manner. The flap valve 38 is preferably made of a pliable medical grade plastic, while the grid structure 46, the remainder of the mouthpiece 12, and the tower or spacer body 16 are all preferably made of a rigid molded plastic, such as ABS, and may be injection molded, if desired.

[0041] FIG. 11 illustrates the flow of aerosol through the mouthpiece airway 48 during inhalation, which as shown by the arrows 52 is along an axial path therethrough, from the distal end 54, which engages the mouthpiece port 14, to the proximal mouth port 40. The flap valve is closed, as shown, during this cycle. During the exhalation cycle, illustrated in FIG. 10, the exhaled air is directed, as shown by arrows 56, through the exhaust port 34, filter 36, and now-opened flap valve 38.

[0042] FIGS. 12-15 illustrate another embodiment of the claimed invention, which is disclosed to emphasize that various arrangements of the components of the inventive device are contemplated within the scope of the invention, and also to illustrate in additional detail the inventive flexible universal boot, or fitting, of the present invention. In this embodiment, like elements are designated by like reference numerals, preceded by the numeral 1. Illustrated is an aerosol enhancement device 110 is similar to that of the device 10 in FIGS. 1-11. However, a generally rectangular tower or spacer body 116 is disclosed, rather than the generally octagonal spacer body 16 of FIGS. 1-11. Applicants believe this to be a less desirable tower body configuration, but it is still potentially viable within the context of the entire inventive concept of Applicants. As in the prior embodiment, this embodiment is useful for a variety of applications, including usage with a nebulizer 158 or MDI 160. Of particular note in FIGS. 12-15 is a more particular illustration of one preferred form of the universal boot or fitting 124 for securing either the nebulizer or MDI, for example, to the spacer body 116. The adaptive fitting 124 includes an engagement flange 162, a rigid connector end 164, and a flexible connector end 166. The flexible connector end 166 is preferably in the nature of a boot, fabricated of a soft pliable material, such as Neoprene, while the engagement flange 162 and rigid connector end 164 are preferably fabricated of a medical grade rigid plastic, such as ABS, which, as discussed above, may be the same material that is used to fabricate the remainder of the device.

[0043] The purpose of the adaptive fitting 124 is to permit the tower body 116 to be able to accommodate attachment of the device to both the nebulizer 158 and the MDI 160, as discussed above. As is shown in FIGS. 12 and 13, the

smaller, rigid connector end **164** may be used to attach the device **110** to a nebulizer **158**. On the other hand, an MDI typically has a non-round mouthpiece **168**, and therefore the inventors have found that a pliable boot connector such as connector **166** is required for a successful fit, by providing a flared access for the MDI boot, as shown in FIG. **13**.

[0044] FIG. **16** illustrates yet another embodiment of the invention, wherein any of the prior embodiments of the device **10**, such as the embodiment shown in FIG. **4**, may be installed for use with a ventilator **170**, of a type well known for the purpose of providing breathing assistance for patients unable to adequately breathe on their own. Such an installation merely involves attaching the air inlet port **22** (or **20**, depending upon the selection of the practitioner) to the ventilator **170**, using an air line **172**. The inventive aerosol enhancement device **10**, **110** otherwise operates in the same manner as above described.

[0045] Presently preferred design options include holding chamber volumes ranging from 90 cc to 140 cc, and chamber lengths ranging from 2.95 inches to 1.56 inches, depending upon the chamber volume and the internal diameter of the chamber. The total stacked height of the inventive apparatus, including an attached nebulizer, may range from 6.7 to 8.3 inches in the presently preferred embodiments, depending upon chamber volume and internal diameter.

[0046] In operation, in any of the illustrated embodiments, the apparatus **10**, **110** is particularly adapted for dual use applications, as noted supra. In particular, the device **10**, **110** may be utilized in conjunction with a nebulizer, wherein the tower **16**, **116**, and in particular, the mixing chamber **18**, **118** functions to recirculate medication introduced by the nebulizer, in order to provide a denser application of medication to the patient. The provided fittings are universally suitable for attachment to any known nebulizer. In an alternative configuration, wherein the device **10**, **110** is utilized in conjunction with an MDI, the tower **16**, **116** functions as a spacer, for the purpose of ensuring a more uniformly mixed dose of medication to the patient.

[0047] Whether the device **10**, **110** is being used with a nebulizer or an MDI, the purpose of the holding chamber **18**,

118 is to repeatedly capture the generated aerosol from the nebulizer or MDI into the fixed volume chamber, which allows for a concentrated bolus of medicated aerosol to be delivered with each breath taken by a patient who is breathing through the mouthpiece **12**. In the case of a nebulizer **158**, the medicated aerosol is drawn therefrom by the vacuum created by inspiration by the patient through the mouthpiece, while in the case of an MDI, a propellant injects the medicated aerosol therefrom into the chamber **18**, **118**. Though not shown, in some embodiments, a bridge adapter may be employed to adapt the device to various prior art mouthpieces.

[0048] The apparatus and method of the present invention may be embodied in other specific forms without departing from its spirit or essential characteristics. The described embodiments are to be considered in all respects only as illustrative and not restrictive. The scope of the invention is, therefore, indicated by the appended claims rather than by the foregoing description. All changes which come within the meaning and range of equivalency of the claims are to be embraced within their scope.

1.-20. (canceled)

21. A universal adaptive fitting for attaching an inlet port for receiving a medicated aerosol on a spacer member of an aerosol enhancement device to a source of medicated aerosol, comprising:

a first rigid connector end; and

a second flexible connector end.

22. The universal adaptive fitting as recited in claim 21, wherein said adaptive fitting further comprises an engagement flange disposed between said first rigid connector end and said second flexible connector end.

23. The universal adaptive fitting as recited in claim 22, wherein said first rigid connector end is tubular.

24. The universal adaptive fitting as recited in claim 22, wherein said second flexible connector end comprises a pliable boot connector.

* * * * *