



US00RE38033E

(19) **United States**
(12) **Reissued Patent**
Okonski et al.

(10) **Patent Number:** **US RE38,033 E**
(45) **Date of Reissued Patent:** **Mar. 18, 2003**

- (54) **PANEL CUTTING APPARATUS**
- (75) Inventors: **Frank Okonski**, Harwood Heights, IL (US); **Edward J. Porento, Sr.**, Des Plaines, IL (US)
- (73) Assignee: **Best Cutting Die Company**, Skokie, IL (US)

- 3,128,681 A 4/1964 Miller
- 3,172,321 A 3/1965 Schrader
- 3,209,630 A 10/1965 McCartan
- 3,257,885 A 6/1966 Hornung
- 3,270,602 A 9/1966 Kirby et al.
- 3,522,754 A 8/1970 Sauer
- 3,530,794 A 9/1970 Ritzerfeld

(List continued on next page.)

FOREIGN PATENT DOCUMENTS

- (21) Appl. No.: **09/161,121**
- (22) Filed: **Sep. 25, 1998**

- EP 0312422 B1 4/1992
- EP 0519661 A1 12/1992
- GB 2133734 8/1984

Related U.S. Patent Documents

Reissue of:

- (64) Patent No.: **5,570,620**
- Issued: **Nov. 5, 1996**
- Appl. No.: **08/186,439**
- Filed: **Jan. 25, 1994**

Primary Examiner—Boyer Ashley

(74) *Attorney, Agent, or Firm*—Michael Best & Friedrich, LLC

(57) **ABSTRACT**

U.S. Applications:

- (63) Continuation-in-part of application No. 08/172,033, filed on Dec. 22, 1993, now abandoned.
- (51) **Int. Cl.**⁷ **B31B 19/14**; B31B 21/14
- (52) **U.S. Cl.** **83/24**; 83/346; 83/698.21; 83/698.42; 83/911; 83/152
- (58) **Field of Search** 83/13, 37, 24, 83/343, 346, 347, 98, 99, 100, 152, 698.21, 40, 698.41, 698.42, 698.51; 492/8, 31; 101/DIG. 36, 486

A rotary cutting assembly is provided for cutting a panel from an envelope blank or the like. The die holder has an outer surface and a plurality of surface orifices radially communicating with corresponding feed tubes for supplying vacuum or air to the surface and into the vicinity of the envelope blank. A novel air delivery assembly is provided for delivering vacuum and/or air to the die holder comprising a stationary plate disposed at least at one end of the die holder and defining a groove member for selectively supplying vacuum and/or air so that when rotation of die holder aligns the longitudinal feed tubes with the groove member a supply of vacuum or air is selectively supplied at the surface orifices of the die holder. Another embodiment of the die holder may have an outer surface having an extending along the longitudinal axis for detachably receiving the leading end of the cutting die and a plurality of magnetic members disposed in the die holder surface for attracting the cutting die. In order to maximize the number of orifices while minimizing the number of magnetic members, it is preferred that the magnetic members be disposed in a plurality of rows wherein each row contains alternating magnets and orifices and a row of orifices are disposed between each adjacent row of magnets. A novel valve assembly is provided for controlling the flow of air to the surface orifices.

(56) **References Cited**

U.S. PATENT DOCUMENTS

- 1,746,048 A 2/1930 Novick
- 1,766,244 A 6/1930 Cumfer
- 1,927,728 A 9/1933 Wolff
- 2,055,295 A 9/1936 Kessler
- 2,791,276 A 5/1957 Weller
- 2,837,025 A 6/1958 Pechy
- 2,898,854 A 8/1959 Crawford
- 3,008,366 A 11/1961 Taylor, Jr.
- 3,106,121 A * 10/1963 Novick 83/152

45 Claims, 13 Drawing Sheets

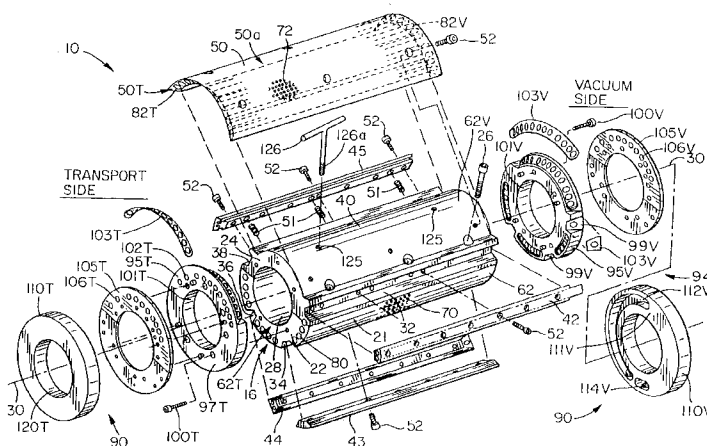

U.S. PATENT DOCUMENTS

			4,549,454 A	10/1985	Yamashita	
			4,645,484 A	2/1987	Niske	
			4,671,152 A	6/1987	Blumle	
			4,726,804 A	2/1988	Stitcher	
			4,742,769 A	5/1988	Zeller	
			4,809,609 A	3/1989	Sugiura et al.	
			4,823,659 A	4/1989	Falasconi	
			4,878,407 A	11/1989	Harrison et al.	
			4,982,639 A	1/1991	Kirkpatrick	
			5,074,180 A	12/1991	Mayer et al.	
			5,095,830 A	3/1992	Love	
			5,109,741 A	5/1992	Fuchs	
			5,119,707 A	6/1992	Fischer	
			5,186,108 A	2/1993	Hillebrand	
			5,230,271 A	7/1993	Hardisty et al.	
			5,419,224 A	* 5/1995	Gamperling et al.	83/100
			5,452,634 A	* 9/1995	Wilson	83/99
			5,505,109 A	* 4/1996	Okonski et al.	83/622
			5,570,620 A	* 11/1996	Okonski et al.	83/152
			5,697,277 A	* 12/1997	Okonski et al.	83/522.15
			5,701,789 A	* 12/1997	Okonski	83/13
3,533,355 A	10/1970	Wall				
3,618,438 A	11/1971	Simson				
3,670,646 A	6/1972	Welch, Jr.				
3,730,092 A	5/1973	Pickard et al.				
3,744,384 A	7/1973	Jarritt et al.				
3,752,042 A	8/1973	Castille				
3,789,715 A	2/1974	Schuchardt et al.				
3,797,351 A	3/1974	Jones, Jr.				
3,810,055 A	5/1974	Wright				
3,824,927 A	7/1974	Pugh et al.				
3,850,059 A	11/1974	Kang				
3,965,786 A	6/1976	D'Luhny				
3,975,976 A	8/1976	Prentice				
4,004,479 A	1/1977	Bodnar				
4,020,724 A	5/1977	Quinlan				
4,127,265 A	11/1978	Wirz et al.				
4,233,873 A	11/1980	Jessen				
4,237,786 A	12/1980	Sanford				
4,270,910 A	6/1981	Himmelsbach				
4,289,492 A	9/1981	Simpson				
4,450,740 A	5/1984	Chapman, Jr. et al.				
4,537,588 A	8/1985	Ehlscheid et al.				

* cited by examiner

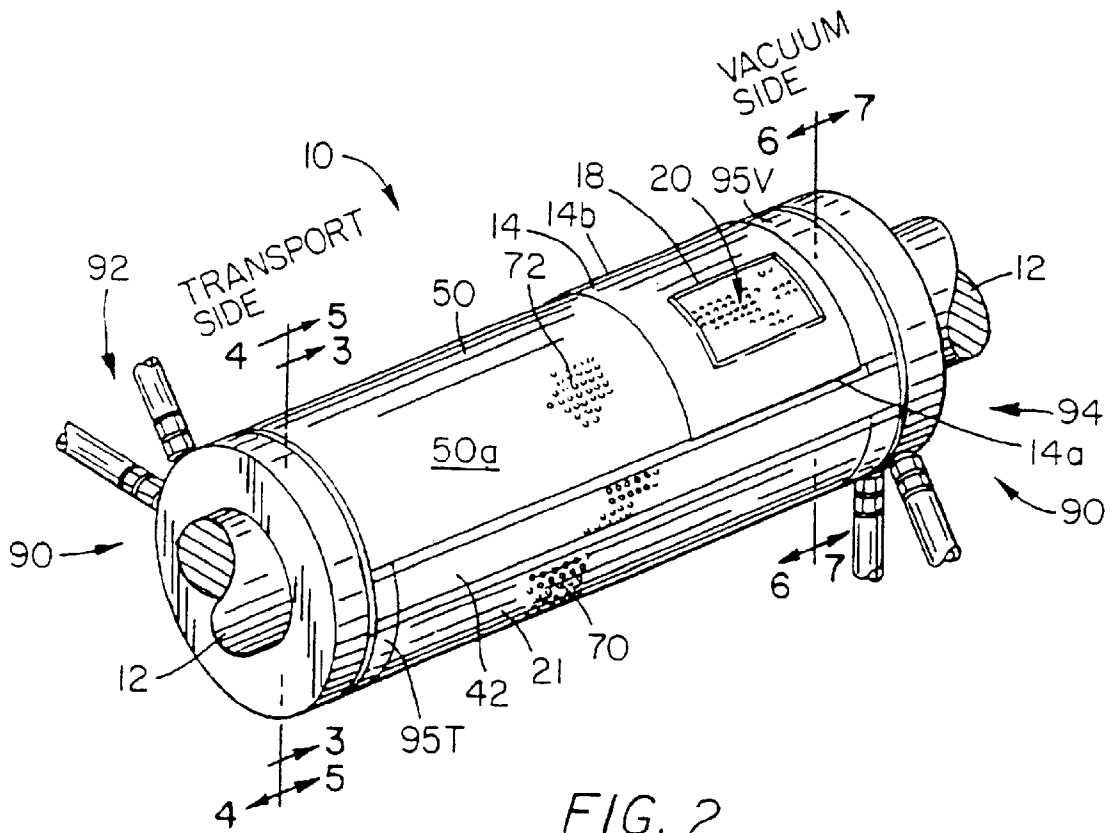

FIG. 2

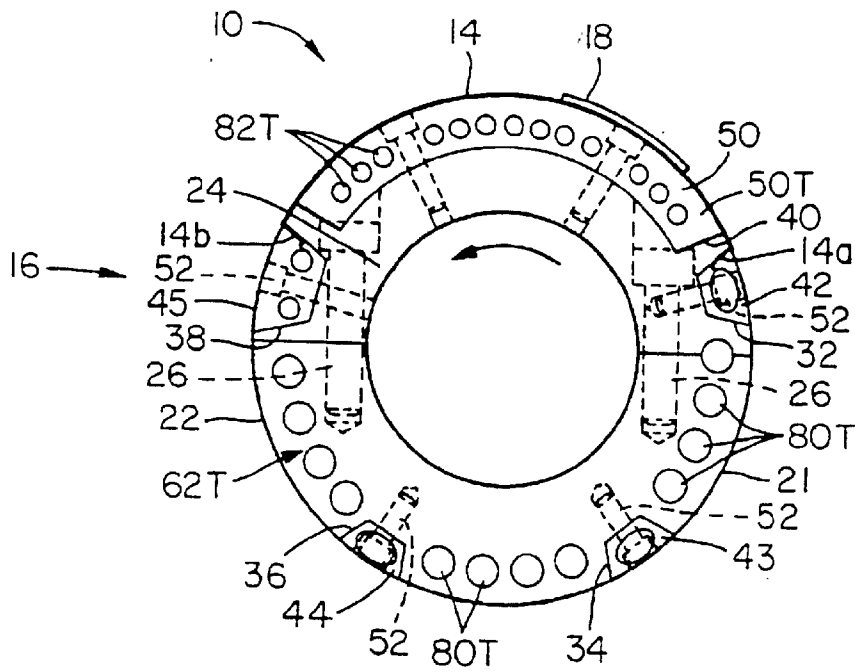

FIG. 3

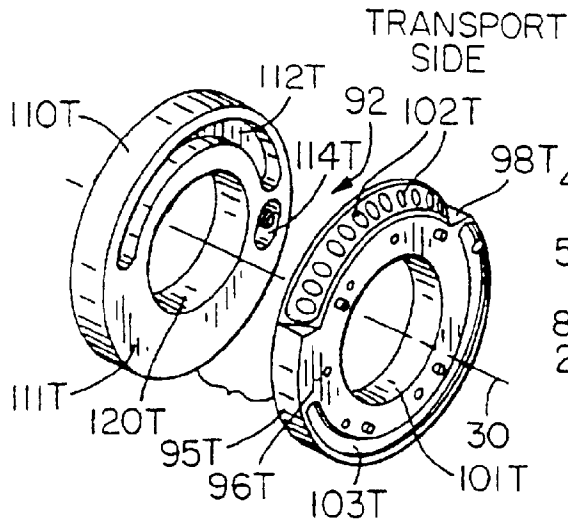

FIG. 4

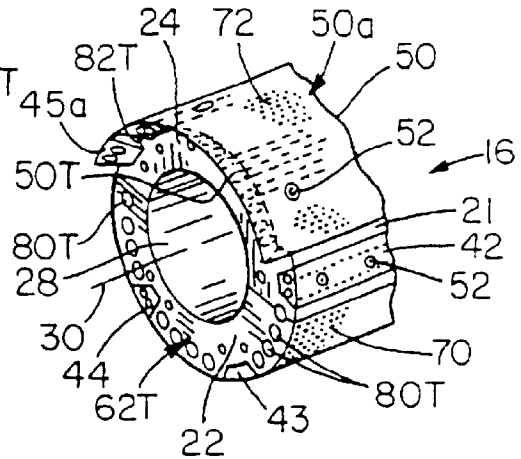

FIG. 5

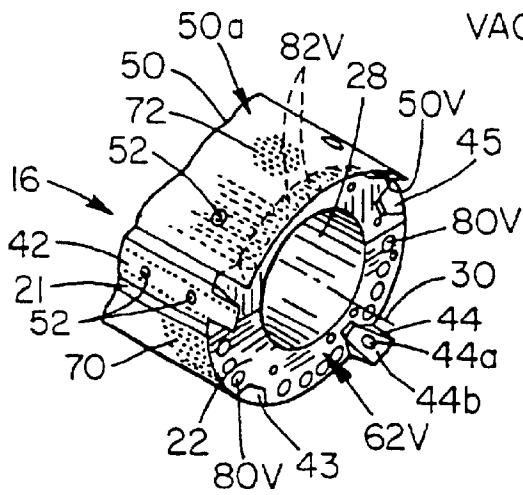

FIG. 6

VACUUM SIDE

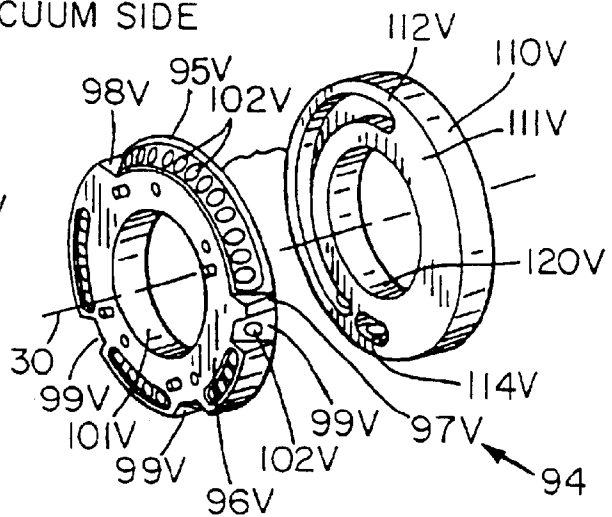

FIG. 7

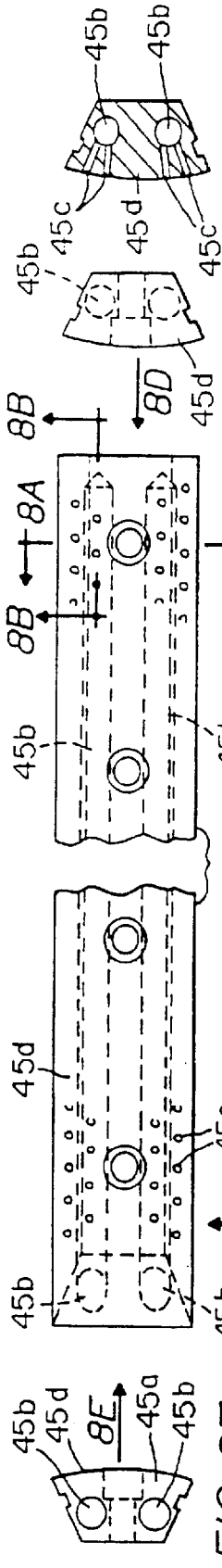

FIG. 8A

FIG. 8B

FIG. 8C

FIG. 8D

FIG. 8E

FIG. 8F

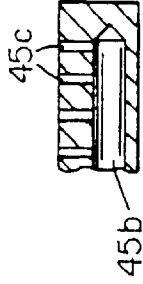

FIG. 8B

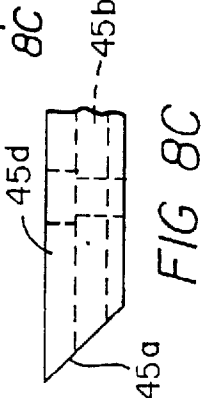

FIG. 8C

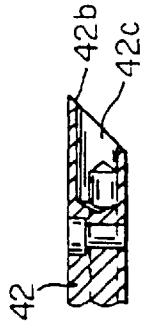

FIG. 9A

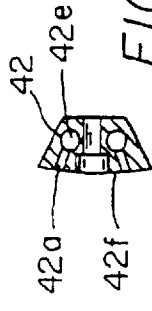

FIG. 9B

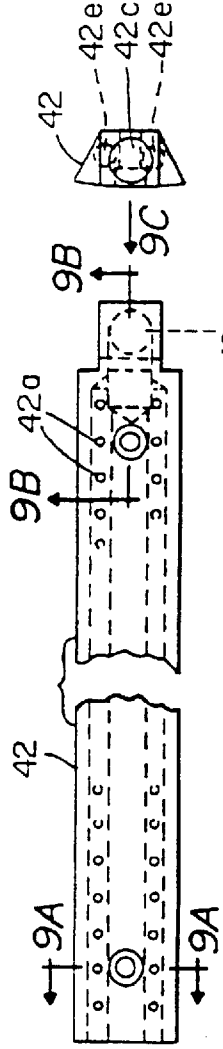

FIG. 9C

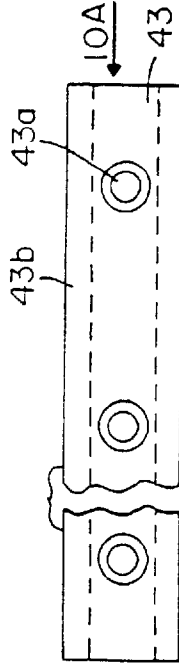

FIG. 10

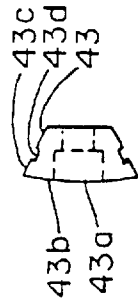

FIG. 10A

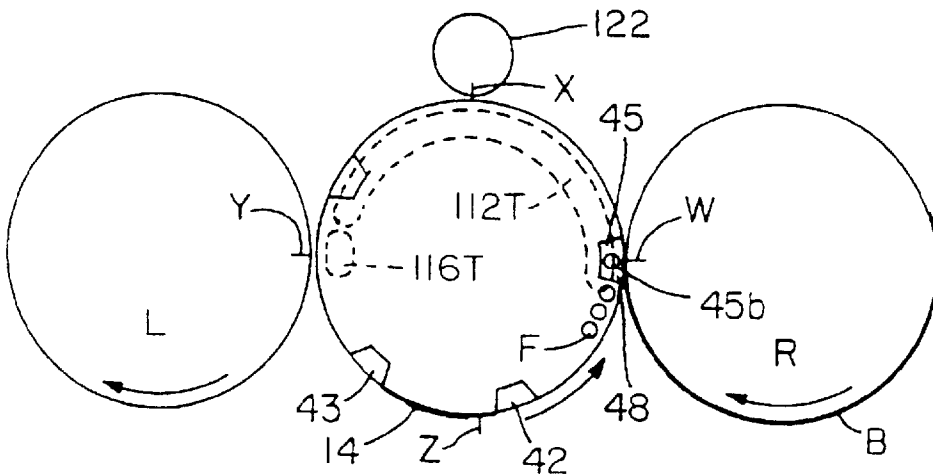

FIG. 11A

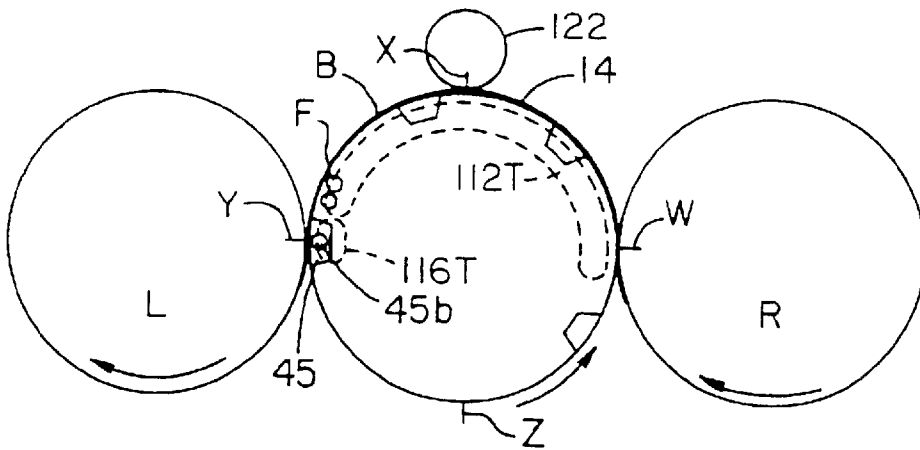

FIG. 11B

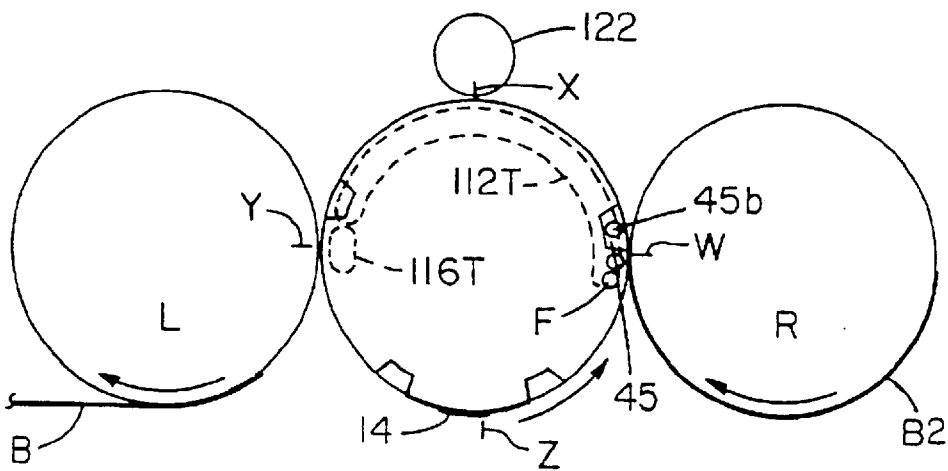

FIG. 11C

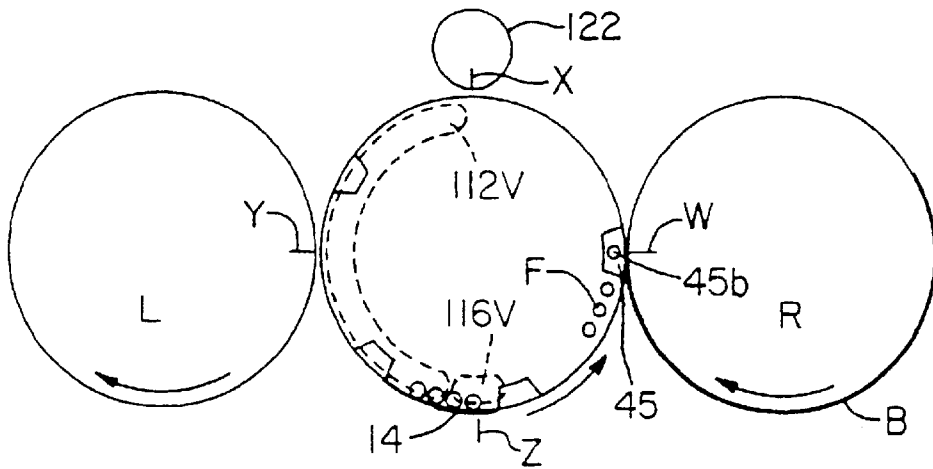

FIG. 12A

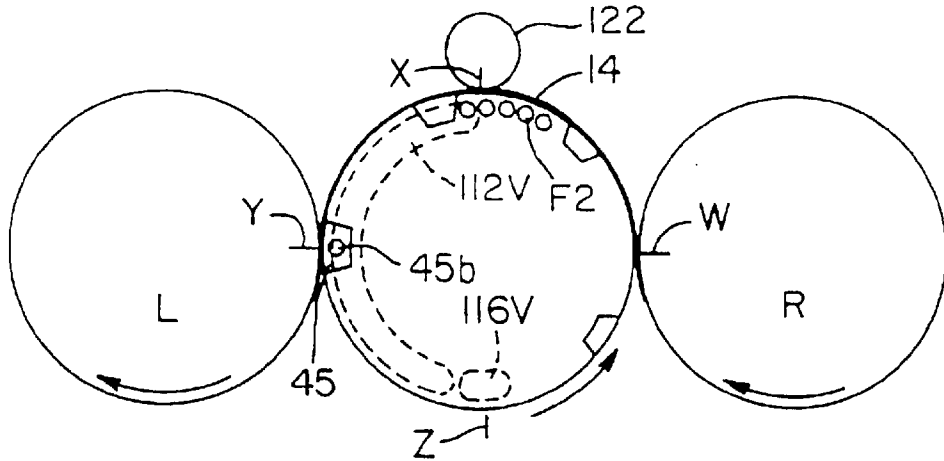

FIG. 12B

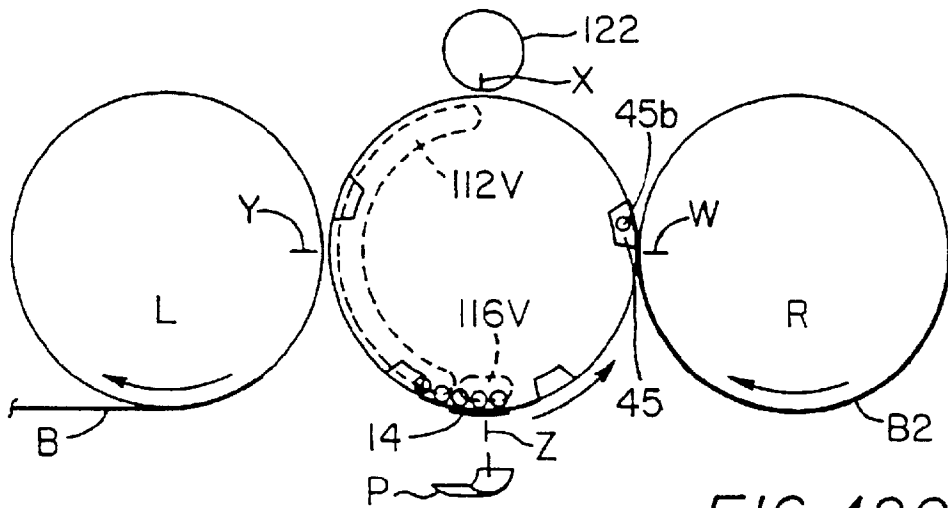

FIG. 12C

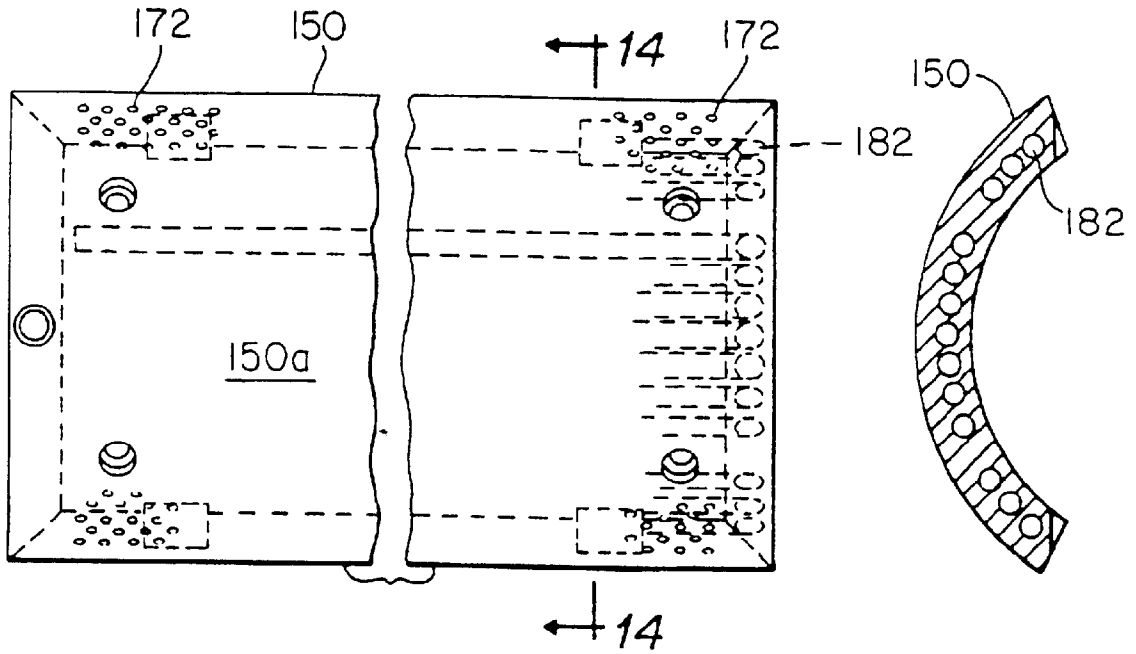

FIG. 13

FIG. 14

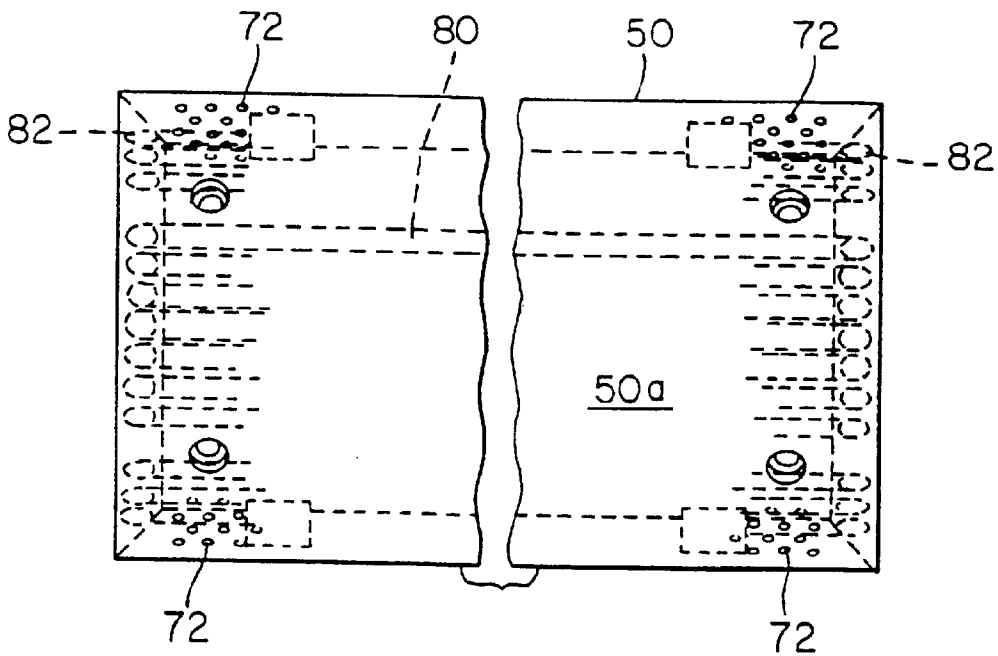

FIG. 15

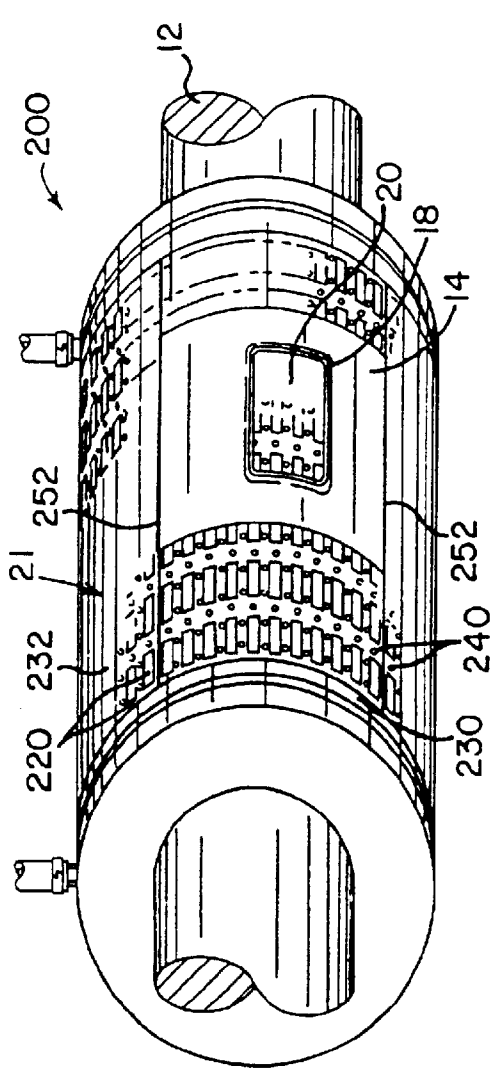
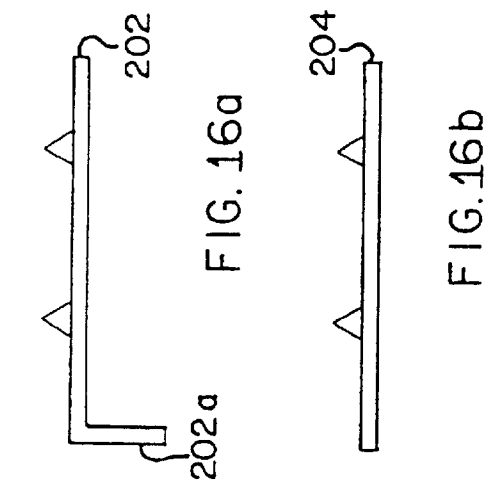

FIG. 17

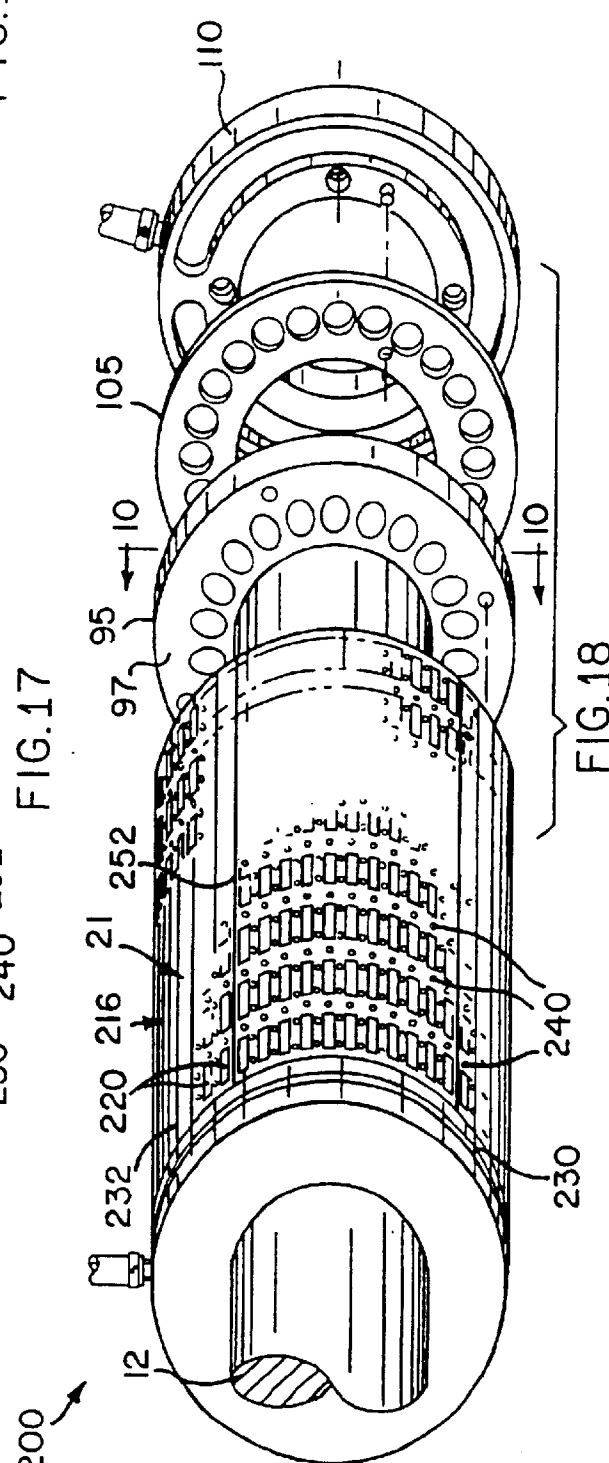

FIG. 18

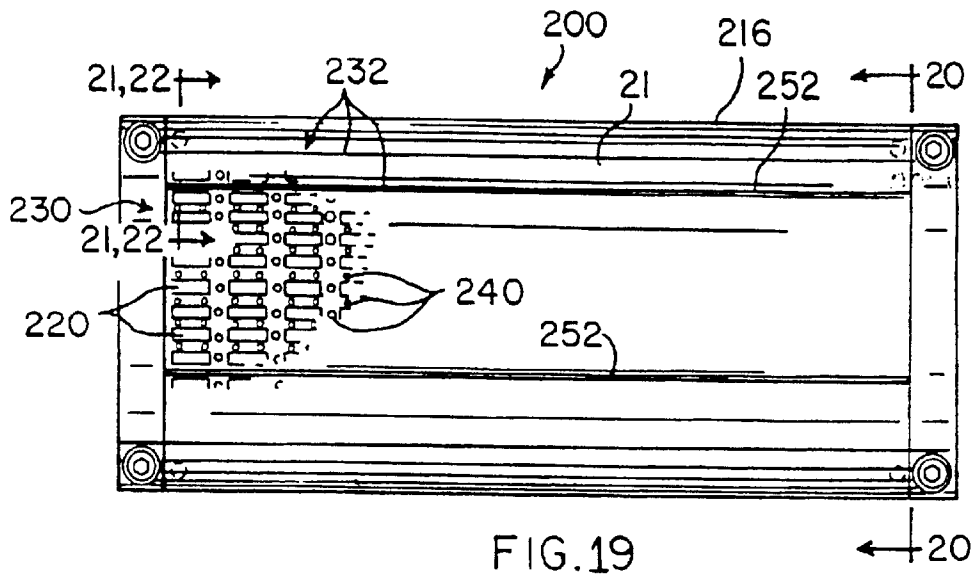

FIG. 19

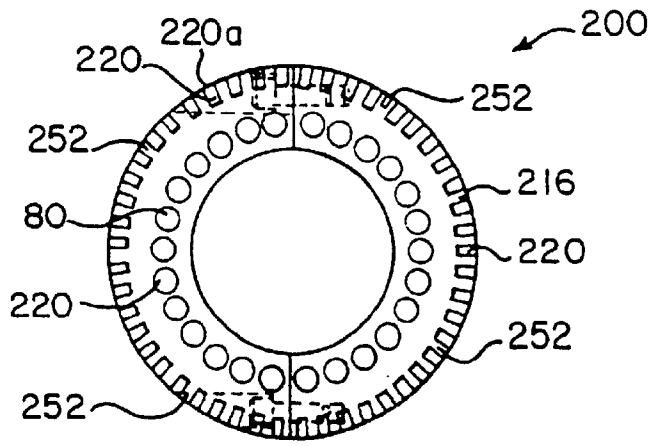

FIG. 20

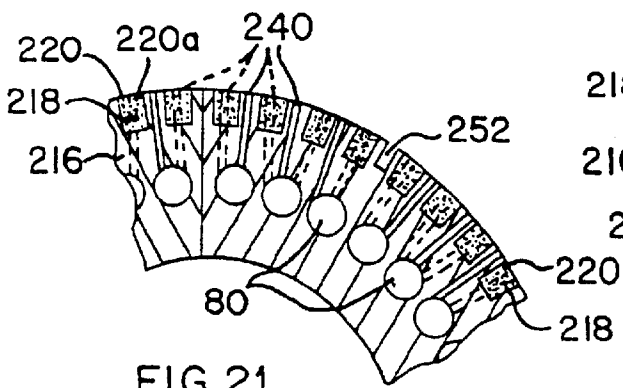

FIG. 21

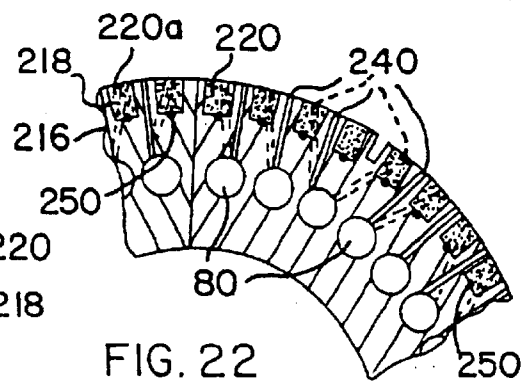
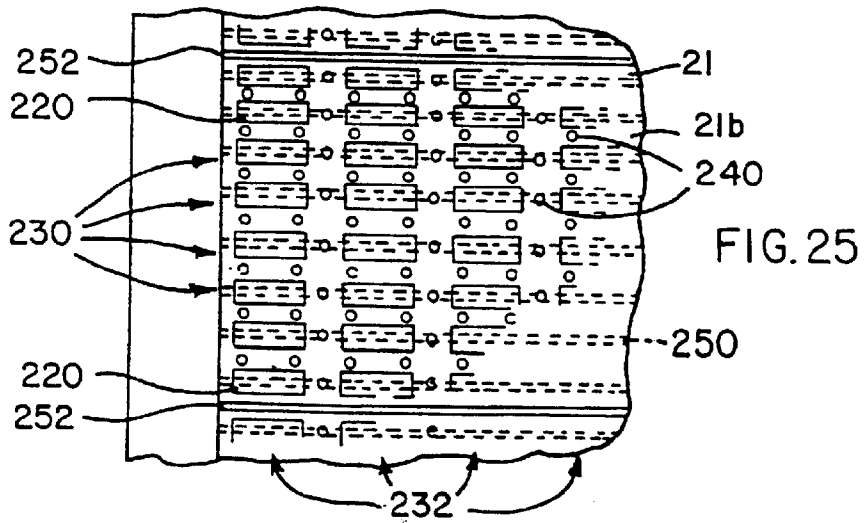
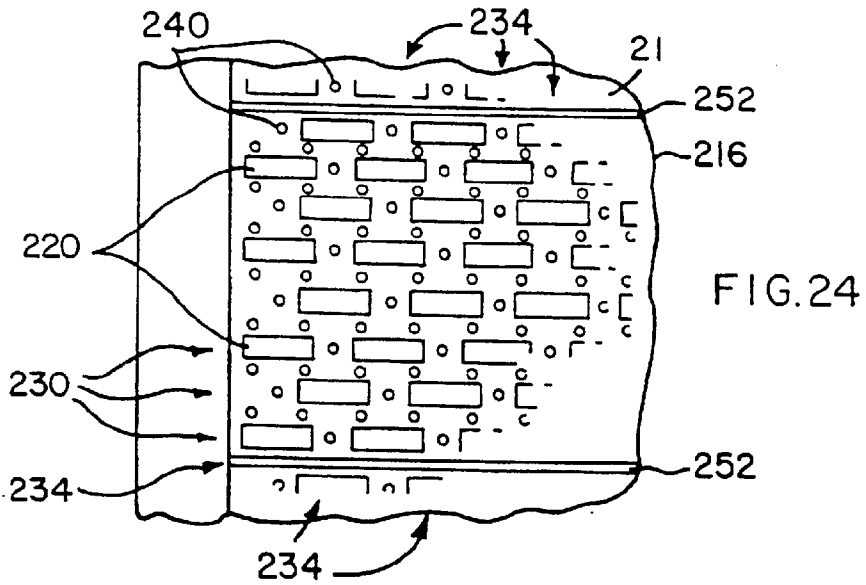
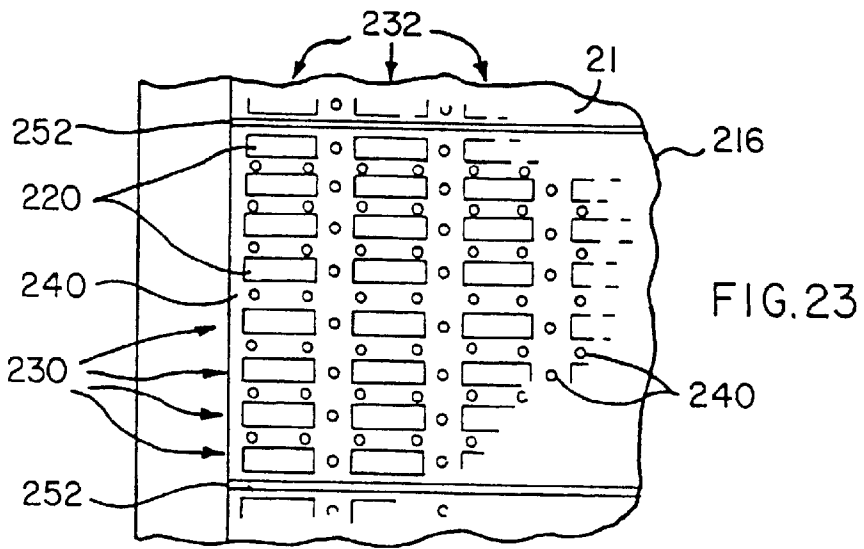

FIG. 22



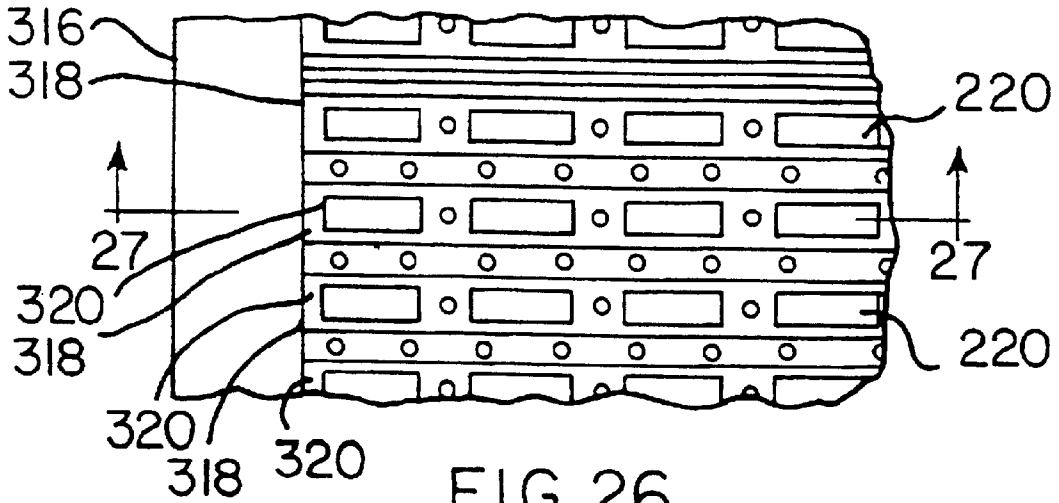

FIG. 26

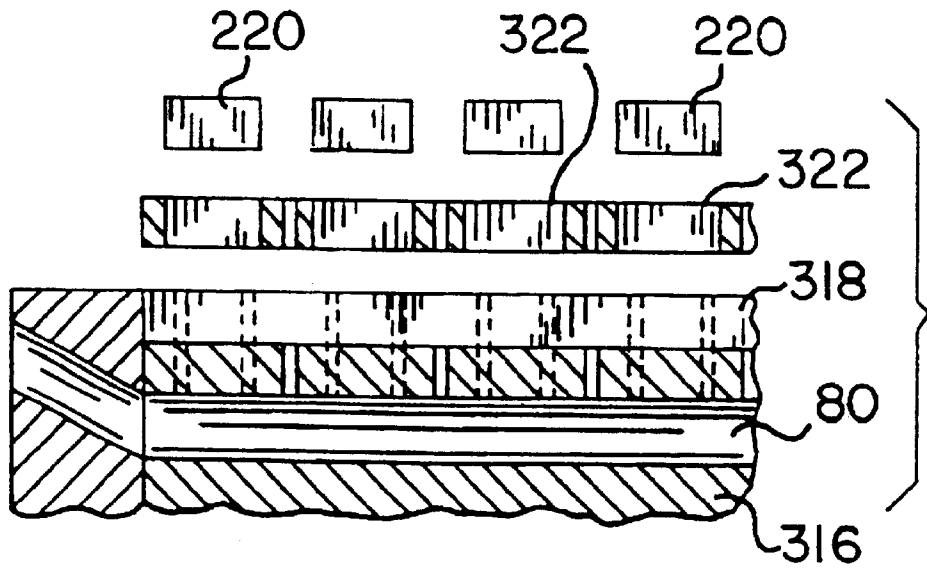

FIG. 27

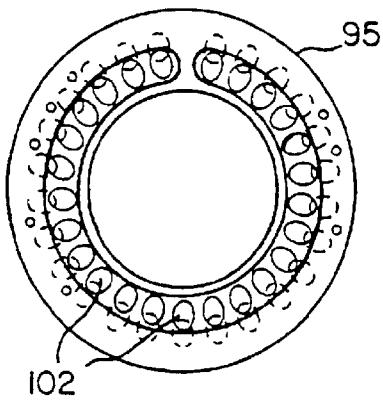

FIG. 28

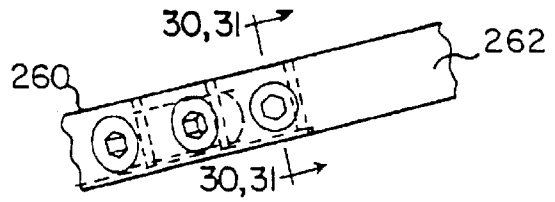

FIG. 29B

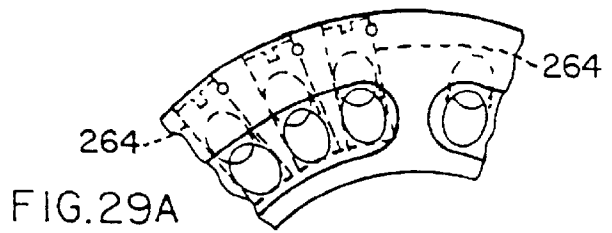

FIG. 29A

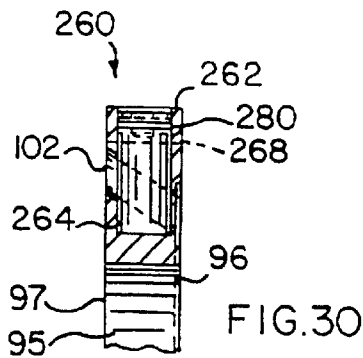

FIG. 30

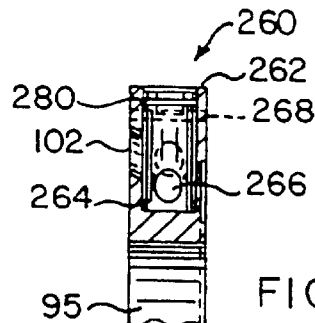

FIG. 31

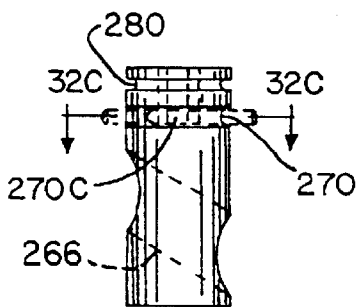

FIG. 32A

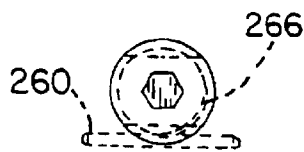

FIG. 32B

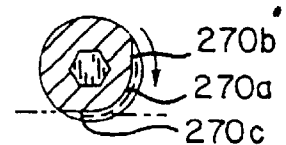

FIG. 32C

PANEL CUTTING APPARATUS

Matter enclosed in heavy brackets [] appears in the original patent but forms no part of this reissue specification; matter printed in italics indicates the additions made by reissue.

RELATED APPLICATIONS

This is a continuation-in-part of application Ser. No. 08/172,033, filed Dec. 22, 1993, now abandoned.

FIELD OF THE INVENTION

The present invention relates generally to a rotary cutting device and more particularly a device for the cutting of windows, notches, orifices or other patterns in relatively thin, flexible sheet-like material in either sheet or web form.

BACKGROUND OF THE INVENTION

Many envelopes have a transparent panel or window for allowing visual inspection of the enclosure. These window envelopes are manufactured from a web of paper material which is initially cut into blanks having a predetermined shape. A panel is subsequently cut from the blank by a panel cutting apparatus to form the window. Thereafter, the blank is then folded, gummed, printed and packaged to form the finished envelope.

U.S. Pat. No. 4,823,659 to Falasconi describes a conventional rotary panel cutting apparatus comprising a cutting tool in the form of a cutting plate or die and a rotary die holder which brings the cutting die into successive contact with the envelope blanks which advance on a conveyor system. The cutting die has a raised cutting edge which is adapted to engage the blank and cut the panel. The die holder, sometimes called a die cylinder or drum, is mounted for rotation on a drive shaft synchronized with the conveyor system so that the cutting die engages a different envelope blank for each rotation of the die holder.

The surface of the die holder has a plurality of transport and vacuum orifices which communicate with corresponding air chambers which, in turn, selectively communicate with a source of vacuum or compressed air. The transport orifices are adapted to engage the envelope blank and, when the vacuum source is activated, carry the blank adjacent to the surface of the die holder. The rotation of the die holder carries the envelope to a cutting station where the blank is passed between the cutting die and a cutting bar so as to cut the panel in the envelope blank. The vacuum orifices are disposed within the periphery of the dies' cutting edges and, when the vacuum source is activated, form a localized vacuum zone within the vicinity of the cutting die to retain and carry away the panel which is cut from the envelope blanks. The envelope blank and the cut panel may be released from the die holder and the cutting die, respectively, by terminating the vacuum source or applying the compressed air to the transport and vacuum orifices. The vacuum and compressed air supply to each opening is controlled by means of valves or attachment tubes which are manually attached to each individual orifice. The attachment tubes typically rotate in unison with the die holder.

Unfortunately, the prior art panel cutting apparatuses suffer from numerous drawbacks. Since the die holder typically rotates from zero to about 1500 rpm, it is extremely difficult to obtain a proper seal between the rotating vacuum tubes and the feed tubes which permits the envelope blank to move, resulting in improper alignment between the cut-

ting die and the envelope blank. Similarly, it is extremely difficult to obtain a proper seal at the vacuum orifices between the die holder and the drive shaft due to wear and abrasion, resulting in insufficient vacuum to carry the envelope blank and the panel and jamming of the cutting apparatus. It is also difficult to apply the vacuum or air at the correct time during the rotation of the die holder.

Methods used to retain the cutting die adjacent to the die holder including mechanical clamp assemblies and magnetic clamp assemblies suffer several disadvantages. The mechanical clamp assemblies, which clamp one or both of the leading and trailing ends of the cutting die, are relatively complicated devices which are time consuming to assemble and disassemble and expensive and difficult to manufacture.

Another drawback is the lack of adjustability of the apparatus to cut out panels of different sizes as well as different locations on the blank. Attempts to provide an adjustable die holder capable of receiving different size cutting dies have been unsuccessful because the holding mechanisms, such as removable cover plates and holding keys, used to attach the cutting dies to the die holders leave significant areas without the vacuum orifices necessary to carry the envelope blank and the panel. In addition, these attempts have resulted in die holders which become unbalanced during rotation.

In order to minimize the assembly and disassembly downtime, magnetic clamp assemblies, having magnetic strips disposed in the surface of the die holder to magnetically attract and hold the cutting die, have been used. Unfortunately, the forces resulting from the rotation of the die holder may cause the cutting die to slide laterally on the surface of the magnets. To prevent the lateral movement of the cutting die, magnetic die holders have also utilized cumbersome mechanical clamping assemblies to hold at least the leading end of the cutting die while the magnetic clamps hold the remaining portion of the cutting die. Attempts to prevent lateral movement by increasing the magnetic force and maximizing the number of magnetic strips disposed in the die holder surface have resulted in minimizing the number of the vacuum orifices available for retaining the envelope blank and the panel.

OBJECTS AND SUMMARY OF THE INVENTION

Accordingly, it is an object of the invention is to provide an improved cutting tool for cutting panels from blanks of sheet-like material.

It is an object of the invention to provide a cutting tool having an improved air delivery system.

It is a more specific object of the invention to provide an improved air delivery system which efficiently delivers vacuum to the die holder with minimal leakage.

It is another object of the invention to provide a die holder which minimizes air leakage due to wear or abrasion.

Another object of the invention is to provide an improved die holder for a panel cutting tool.

Still another object of the invention is to provide a die holder which maximizes the vacuum openings disposed along its outer surface. A related object is to provide a cover plate and a holding key which is capable of retaining the envelope blank and the panel during the cutting operation.

It is an object of the invention to provide a die holder which functions in an efficient manner, is easily assembled and is adapted for operation with different size cutting dies.

It is a related object of the invention to provide a die holder which may be easily and readily adjusted to position the cutting die.

It is an object of the invention to provide a die holder having a more equal weight distribution.

It is an object of the invention to provide a die holder which may be easily removed from the die shaft.

It is an object of the invention to provide an improved magnetic cutting tool for cutting patterns from blanks of sheet-like material.

It is an object of the invention to provide a cutting tool having an improved distribution of magnets and air orifices.

A more specific object of the invention is to provide a magnetic cutting tool which minimizes the number of magnetic strips while maximizing the number of vacuum orifices disposed over the die holder surface.

Another object of the invention is to provide a magnetic die holder which prevents the cutting die from moving laterally on the die holder surface.

A rotary cutting assembly is provided for cutting a panel from an envelope blank or the like. The cutting assembly comprises a cutting die mounted on a die holder adapted to be mounted on a drive shaft for rotating about an axis. The die holder has a plurality of surface orifices radially communicating with corresponding longitudinally directed feed tubes for supplying vacuum or air to the surface and into the vicinity of the envelope blank.

In accordance with one aspect of the invention, a novel air delivery assembly is provided for delivering vacuum and/or air to the die holder. The air delivery assembly comprises a stationary plate disposed at least at one end of the die holder and defining a groove member for selectively supplying vacuum and/or air so that a supply of vacuum or air is selectively supplied at the surface orifices of the die holder when rotation of the die holder aligns the longitudinal feed tubes with the groove member.

In one embodiment, the air delivery assembly comprises a transport assembly and a vacuum assembly disposed on opposing sides of the die holder. The transport assembly is adapted to feed vacuum to the die holder in order to retain the envelope blank adjacent to the die holder and "transport" the envelope blank as the holder rotates through the cutting operation. The vacuum assembly, in turn, is adapted to feed vacuum to the die holder in order to retain the panel cut from the envelope blank adjacent to the die holder until a predetermined position is reached wherein the panel is released from the die holder. At predetermined positions, the transport and vacuum assemblies may feed compressed air to the die holder in order to release the envelope blank and the panel, respectively.

In accordance with certain objects of the invention, the die holder has at least one groove for receiving a holding key which cooperate to clamp one of the edges of the cutting die therebetween for securing the cutting die to the holder. In one embodiment, the holding key may have a plurality of orifices for supplying vacuum or air to the surface of the key and at least one longitudinally directed feed tube which radially communicates with the orifices for supplying vacuum and/or air to the orifices. In another embodiment, a transport key is provided which is adapted to engage and retain the leading edge of the envelope blank adjacent to the outer surface of the key as the die holder rotates. A feeder key is also provided which is adapted to engage and retain the envelope blank or the panel cut from the blank adjacent to the outer surface of the key as the die holder rotates.

In accordance with certain objects of the invention, the die holder may have a removable cover plate having a plurality of orifices disposed on the plate surface and feed tubes

subjacent the plate surface which communicate with the orifices for supplying vacuum or air to the orifices. In one embodiment, the feed tube extends in the longitudinal direction so as to communicate with both ends of the cover plate.

In another embodiment, the feed tube only communicates with one end.

The operator may select whether individual feed tubes (and the corresponding orifices) communicate with either the transport assembly or the vacuum assembly. In applications where the envelope blank is adjacent to the certain predetermined orifices and it is desired to retain the envelope blank adjacent the die holder, the feed tubes corresponding to the predetermined orifices communicate with the transport assembly. Conversely, if the panel is adjacent to the predetermined orifices, the feed tubes corresponding to the predetermined orifices communicate with the vacuum assembly.

In accordance with certain objects of the invention, the die holder may have an outer surface having a slot extending along the longitudinal axis for detachably receiving the leading end of the cutting die and a plurality of magnetic members disposed in the die holder surface for attracting the cutting die. In a preferred embodiment, the die holder may have a plurality of orifices disposed between adjacent magnetic members for delivering vacuum or air to the die holder surface. In order to maximize the number of orifices while minimizing the number of magnetic members, it is preferred that the magnetic members be disposed in a plurality of rows wherein each row contains alternating magnets and orifices and a row of orifices are disposed between each adjacent row of magnets.

These and other features and advantages of the invention will be more readily apparent upon reading the following description of a preferred exemplified embodiment of the invention and upon reference to the accompanying drawings wherein:

BRIEF DESCRIPTION OF THE DRAWINGS

FIG. 1 is an exploded view of a rotary cutter assembly in accordance with the present invention;

FIG. 2 is a perspective view of the assembled rotary cutter shown in FIG. 1;

FIG. 3 is a sectional view of the transport face of the die holder taken along line 3—3 in FIG. 2;

FIG. 4 is an exploded view of the connector die and the stationary plate (transport side) taken along line 4—4 in FIG. 2;

FIG. 5 is a perspective view of the transport face of the die holder taken along line 5—5 in FIG. 2;

FIG. 6 is a perspective view of the vacuum face of the die holder taken along line 6—6 in FIG. 2;

FIG. 7 is an exploded view of the connector plate and the stationary plate (vacuum side) taken along line 7—7 in FIG. 2;

FIG. 8 is a top view of the clamp/transport bar;

FIG. 8A is a view of the clamp/transport bar taken along line A—A in FIG. 8;

FIG. 8B is a view of the clamp/transport bar taken along line B—B in FIG. 8;

FIG. 8C is a view of the clamp/transport bar taken along line C—C in FIG. 8;

FIG. 8D is a view of the clamp/transport bar taken along line D—D in FIG. 8;

FIG. 8E is a view of the clamp/transport bar taken along line E—E in FIG. 8;

FIG. 9 is a top view of clamp/feeder bar;

FIG. 9A is a view of the clamp/feeder bar taken along line A—A in FIG. 9;

FIG. 9B is a view of the clamp/feeder bar taken along line B—B in FIG. 9;

FIG. 9C is a view of the clamp/feeder bar taken along line C—C in FIG. 9;

FIG. 10 is a top view of the clamp bar;

FIG. 10A is a view of the clamping bar taken along line A—A in FIG. 10;

FIG. 11a illustrates the position of the rotary cylinder as transfer cylinder R feeds an envelope blank to the die holder, FIG. 11b illustrates the position of the rotary cutter as a panel is cut from the envelope blank, and FIG. 11c illustrates the position of the rotary cutter as the envelope blank is released to transfer cylinder L and the die holder receives another envelope blank from transfer cylinder R;

FIG. 12a illustrates the position of the rotary cylinder as transfer cylinder R feeds an envelope blank to the die holder, FIG. 12b illustrates the position of the rotary cutter as a panel is cut from the envelope blank and FIG. 12c illustrates the position of the rotary cutter as the envelope blank is released to transfer cylinder L and the die holder receives another envelope blank from transfer cylinder R;

FIG. 13 is a top view of the embodiment of the cover plate illustrated in FIGS. 1—12;

FIG. 14 is a sectional view of the cover plate taken along line 14—14 in FIG. 13;

FIG. 15 is a top view of another embodiment of the cover plate;

FIG. 16 is a perspective view of a cutting die;

FIGS. 16a and 16b are elevational views of alternate embodiments of the cutting die;

FIG. 17 is a perspective view of a magnetic rotary cutter assembly in accordance with the present invention;

FIG. 18 is an exploded view of the rotary cutter assembly shown in FIG. 17;

FIG. 19 is an elevational view of the magnetic die holder;

FIG. 20 is a view of the die holder taken along line 20—20 in FIG. 19;

FIG. 21 is a view of the die holder taken along line 21—21 in FIG. 19;

FIG. 22 is a view of the die holder taken along line 22—22 in FIG. 19;

FIG. 23 is a partial elevational view illustrating one embodiment of the magnetic die holder;

FIG. 24 is a partial elevational view of another embodiment of the magnetic die holder;

FIG. 25 is another view of the magnetic die holder illustrated in FIG. 23;

FIG. 26 is a view of another embodiment of a magnetic die holder;

FIG. 27 is an exploded view of the magnetic die holder taken along line 27—27 in FIG. 26;

FIG. 28 is an elevational view of an end plate having a valve assembly in accordance with the present invention;

FIGS. 29A and 29B are enlarged elevational and top views, respectively, of the end plate and valve assembly shown in FIG. 28;

FIGS. 30—31 are sectional views taken through lines 30—30 and 31—31, respectively, in FIG. 29; and

FIGS. 32A and 32B are elevational and top views respectively, of one embodiment of a valve member; and

FIG. 32C is a sectional view taken along line 32C in FIG. 32A.

While the invention will be described and disclosed in connection with certain preferred embodiments and procedures, it is not intended to limit the invention to those specific embodiments. Rather it is intended to cover all such alternative embodiments and modifications as fall within the spirit and scope of the invention.

DETAILED DESCRIPTION OF THE PREFERRED EMBODIMENT

Referring to the drawings and more particularly to FIGS. 1—2, one embodiment of a rotary cutting tool 10 for cutting panels P and the like from sheet-like material such as envelopes and the like is mounted on a drive shaft 12 in accordance with the present invention. The cutting tool 10 comprises a cutting die 14 mounted on a die holder 16. The drive shaft 12 rotates the die holder 16 so that the cutting die 14 engages a different envelope blank B for each rotation of the die holder 16.

The die holder 16 cooperates with an air delivery assembly in order to receive and retain the envelope blank B during the cutting operation. One embodiment of an air delivery assembly in accordance with certain objects of the invention is generally referenced as 90 although conventional air delivery assemblies may also be used. The die holder 16 has a transport side which is generally depicted as the left side in FIGS. 1 and 2 and a vacuum side which is generally depicted as the right side. The transport side of the die holder 16 is adapted to receive vacuum or compressed air from the air delivery assembly 90 in order to retain and transport the envelope blank B as the die holder 16 rotates through the cutting operation. The vacuum side, in turn, is adapted to receive vacuum or compressed air from the air delivery assembly 90 in order to retain and carry the panel P cut from the envelope blank B adjacent to the die holder 16 until a predetermined position is reached wherein the panel P is released from the die holder 16. The suffix "t" and "v" will be used to denote the transport and vacuum sides, respectively, of the die holder 16. The structure and operation of the rotary cutting tool 10 is explained in greater detail below.

THE CUTTING PLATE

As shown in FIGS. 2, 3 and 16, the cutting die 14 has two opposing sides 14a, 14b for selectively and releasably attaching to the die holder 16. Each side 14a, 14b has a corresponding lip 15a, 15b. The cutting die 14 has a raised cutting edge 18 having a contour corresponding to the outline of the panel P to be cut in the envelope blank B or web. Although any other appropriate shapes may be used, the cutting edge 18, in the illustrated embodiment, has a rectangular contour to cut a rectangular panel P from the blank B.

The cutting die 14 also comprises a central opening 20 which is defined by the cutting edge 18. The cutting die opening 20 permits the die holder 16 and the air delivery assembly 90 to communicate with the envelope blank B through the cutting die 14 so that the die holder 16 may feed vacuum into the vicinity of the cutting edges 18 to retain the panel P in the cutting die 14 and to carry the panel P away from the blank B. Similarly, the opening 20 permits the die holder and the air delivery assembly 90 to feed compressed air into the vicinity of the cutting edges 18 so as to release the panel P from the cutting die 14 at an appropriate time.

THE DIE HOLDER

The rotary die holder 16 is adapted for holding the cutting die 14 in selected positions around its outer surface 21. As

best shown in FIG. 1, the die holder 16 is formed by two semi-cylindrical sections 22 and 24 which are attached to each other by bolts 26 so as to define a cylindrical shape and a central bore 28 adapted to receive the drive shaft 12. The die holder 16 has a longitudinal axis 30 generally extending along the axis of the drive shaft 12. As best shown in the FIG. 3, the illustrated die holder 16 is adapted to rotate in a counter clockwise direction as shown by the arrow. The die holder 16 may utilize magnetic or non-magnetic members disposed about the outer surface, or both, for retaining the cutting die 14.

Referring to FIGS. 1 and 3, the two sections 22, 24 have four grooves 32, 34, 36, 38 and one larger channel 40 extending along the axis 30. Each groove 32, 34, 36, 38 is adapted to receive a holding key which, in the figures, are designated as 42, 43, 44, 45, respectively. The channel 40 is adapted to receive an arcuate cover plate 50. In order to ease disassembly of the key 45 from the die holder 16, the key 45 may be biased by coiled springs 51 compressed between the key 45 and the groove 38 to eject the key 45 from the groove 38 when the screws 52 are released. The other keys 42, 43, 44 and the cover plate 50 may also have similarly biased springs (not shown). When the keys 42, 44, 44, 45 and the cover plate 50 are attached to the two sections 22, 24 using screws 52, a substantially continuous, even and curved outer surface 21 is formed for receiving the die plate 14.

Each key 42, 43, 44, 45 is adapted to cooperate with its corresponding groove 32, 34, 36, 38 to clamp one of the edges 14a or 14b of the cutting die 14 therebetween. Any two keys may be used to selectively mount different size cutting dies 14 to the die holder 16 depending upon the predetermined size and location of the panel P to be cut from the envelope blank B. The die holder 16 may also be adapted to receive other sizes of cutting dies 14 by adding additional keys around the periphery of the die holder 16 or by changing the location of the keys along the periphery of the die holder 16.

In the embodiment illustrated in FIGS. 2-3, for example, a relatively small cutting die 14 for cutting a small panel P is mounted to the die holder 16. The illustrated cutting die 14 is sized so that the two opposing edges 14a, 14b are clamped between the first and fourth keys 42 and 45 and the cutting edge 18 extends over the outer surface 50a of the cover plate 50. The keys 43 and 44 which are not used in the clamping process must be installed in grooves 34 and 36 to provide a substantially even surface 21 for receiving the envelope blank B and to keep the die holder 16 properly weighted and balanced during rotation. If the panel P to be cut is not located entirely on the cover plate 50, another cutting die (not shown) of intermediate length may be used. In such applications, a different size die 14 may be clamped to any of the keys so that the cutting edge 18 is properly positioned along the periphery of the die holder 16 to the cut the panel P.

In order to retain the envelope blank B and the panel P adjacent to the surface 21 of the die holder 16 during the cutting operation, the die holder 16 is capable of feeding vacuum from the air delivery assembly 90 to the outer surface 21 and into the vicinity of the adjacent envelope blank B and panel P. Referring to FIG. 3, it will be seen that the outer surface 21 of the die holder 16 which engages the envelope blank B is generally defined by the exterior surfaces of (1) the cover plate 50, (2) the keys 42, 43, 44, 45 and (3) the two cylindrical sections 22 and 24.

THE CYLINDRICAL BODY

Turning first to the two cylindrical sections 22, 24, it will be seen in FIGS. 1 and 2 that exterior surface of the two

sections 22, 24 which engage the envelope blank B have a plurality of orifices 70 disposed thereon which radially communicate with a plurality of corresponding feed tubes 80 subjacent the surface 21 of the die holder 16. Each feed tube 80 is generally parallel to the longitudinal axis 30 of the die holder 16 and have openings 80t and 80v in the transport and vacuum sides 62t, 62v of the die holder 16. A sealing gasket may be disposed between the section 22, 24 to provide an air-tight seal.

Each feed tube 80 is adapted to communicate with the air delivery assembly 90 so that vacuum may be supplied to the feed tubes 80 so as to create a vacuum in the corresponding orifices 70 and retain the envelope blank B or panel P adjacent to the surface 21 of the corresponding orifices 70. Conversely, supplying compressed air to the feed tubes 80 will blow air through the corresponding orifices 70 and release the envelope blank B or panel P.

By selectively sealing the proper side of the feed tube 80, the operator may select whether the individual feed tube 80 (and the corresponding orifices 70) communicates with either the transport or the vacuum side of the air delivery assembly 90. In applications where the envelope blank B is adjacent to the certain predetermined orifices 70 and it is desired to retain the envelope blank adjacent the die holder 16, the transport side 80t of the feed tubes 80 corresponding to the predetermined orifices 70 are left open so that the feed tubes 80 communicate with the transport side of the air delivery assembly 90 whereas the vacuum side 80v is sealed. Conversely, if the panel P is adjacent to the predetermined orifices 70, the vacuum side 80v of the feed tubes 80 corresponding to the predetermined orifices 70 are left open so that the feed tubes 80 communicate with the vacuum side of the air delivery assembly 90 whereas the transport side 80t are sealed.

As best seen in FIG. 3, it is preferable that the walls defining the feed tubes 80 are separate from the drive shaft 12 so that any abrasion or other wear to the drive shaft 12 or the central bore 28 will not affect the vacuum seal in the feed tubes 80. Similarly, an insufficient seal in one of the feed tubes 80 will not affect the other separate feed tubes 80.

THE COVER PLATE

In order to retain an envelope blank B adjacent the outer surface 50a of the cover plate 50, the cover plate 50 also has a plurality of orifices 72 disposed about its entire outer surface 50a. The orifices 72 communicate with a plurality of corresponding feed tubes 82 subjacent the outer surface 50a of the cover plate 50. Like the feed tubes 80 in the two cylindrical sections 22 and 24 of the die holder 16, the cover plate feed tubes 82 extend generally along the axis 30 of the die holder 16 and are adapted to feed vacuum or compressed air from the air delivery assembly 90 to the air orifices 72 and into the vicinity of the envelope blank B.

In the embodiment of the cover plate 50 best illustrated in FIGS. 1, 5, 6 and 15, the feed tubes 82 extend through the entire length of the cover plate and open to both the transport face 50t and the vacuum face 50v of the cover plate 50 so that the opposing openings 82t, 82v of the feed tube 82 communicate with the transport and vacuum sides.

As with the feed tubes 80 in the cylindrical sections 23 and 24, the operator may select whether the individual feed tube 82 (and the corresponding orifices 72) communicate with either the transport or the vacuum side of the air delivery assembly 90 by selectively sealing one side of the feed tube 82. Referring to FIGS. 2 and 3 for illustrative purposes only, there is shown a cutting die 14 disposed over

the cover plate 50. The operator may utilize a portion of the cover plate orifices 72 to control the retention of the panel P and the remaining orifices to independently control the retention of the envelope blank B. After pre-selecting the specific orifices 72 and the feed tubes 82 which communicate with the cutting die opening 20 (and the panel P), the operator may seal the transport side 82t of these feed tubes 82 so that only the vacuum side of the air delivery assembly 90 (which controls the retention of the panel P) communicates with the orifices 72. However, for the remaining orifices and feed tubes 82 which do not communicate with the cutting die opening 20 and the panel P, the vacuum side 82t of the feed tubes 82 are sealed so that the transport side of the air delivery assembly 90 (which controls the retention of the envelope blank B) communicates with the orifices 72 and envelope blank B adjacent thereto. Thus, it will be appreciated that a portion of the cover plate orifices 72 are utilized to control the panel P and the remaining orifices 72 are utilized to control the envelope blank B.

In applications where the cutting die 14 is not disposed over the cover plate 50, the vacuum side 82v of the feed tubes 82 are sealed whereas the transport side 82t are left open because the cover plate 50 is only utilized to transport the envelope blank B. It should now be appreciated that at least one side of each feed tube 82 must be covered to prevent the transport and vacuum sides of the air delivery assembly 90 from simultaneously communicating with the same feed tube 82.

In another embodiment of the cover plate 150 illustrated in FIGS. 13-14, the feed tubes 182 communicate with one side face of the cover plate 150. In applications where the cutting die 14 is disposed over the cover plate 150, the orifices 172 and feed tubes 180 which do not communicate with the die opening 20 and the associated panel P are sealed and the cover plate 150 is orientated so that the remaining open orifices 172 and feed tubes 182 communicate with the vacuum side of the air delivery assembly 90. Conversely, in applications where the cutting die 14 is not disposed over the cover plate 150, the orifices 172 and feed tubes 182 which communicate with the envelopes blank B are left open and the orientation of the cover plate 150 is reversed so that the feed tubes 172 communicate with the transport side of the air delivery assembly 90.

THE HOLDING KEYS

Three embodiments of the keys used to secure the cutting die 14 to the die holder 16 are illustrated in FIGS. 1-3, 5-6 and 8-10. It is desirable that the holding keys be adapted to be interchangeable with each other and to fit into any of the grooves 32, 34, 36, 38 so that the number of keys necessary for the operation of the die holder 16 are minimized.

A conventional clamping bar 43 which is utilized to clamp the sides 14a, 14b of the cutting die to the die holder 16 is illustrated in FIG. 10. The clamping bar 43, which may be attached to the die holder 16 using screw holes 43a, is not adapted to feed vacuum or air to its outer surface 43b. In order to insure retention of cutting die between the clamping bar 43 and the corresponding groove, the side face 43c of each key preferably has a channel 43e disposed therein for receiving the lip 15a, 15b of the cutting die 14. It will be appreciated that the other holding keys 42, 44 and 45 may also have a channel to receive the die lip 15a, 15b.

One embodiment of a holding key which is also adapted for retaining the leading edge of the envelope blank B adjacent to the die holder surface 21 so that the envelope blank B is accurately and securely held in position during the

rotation of the die holder and when the cutting die cuts the panel P is illustrated by the transport bar 45 illustrated in FIG. 8. If the leading edge is not securely retained by the die holder 16, it is possible that air may lodge underneath the leading edge and cause the envelope blank B to become misaligned, resulting in inaccurate cuts by the cutting die 14. In the embodiment of the transport bar 45 illustrated in FIG. 8, the transport bar 45 has two feed tubes 45b which open to the inclined side face 45a and which communicate with a plurality of the orifices 45c on the outer surface 45d of the transport bar 45. The transport bar 45 may have any number of feed tubes 45b or orifices 45c. The feed tube 45b will be connected to the transport side of the air delivery assembly 90 in order to accurately and securely retain the envelope blank B adjacent to the transport bar surface 45d.

Another embodiment of a key which is capable of feeding vacuum or compressed air to the key surface for retaining the envelope blank B or the panel P thereto is depicted by the feeder bar 42 in FIG. 9. The feeder bar 42 should have at least one feed tube 42e which communicates with a plurality of the orifices 42a on the outer face 42f of the feeder bar 42. In the embodiment illustrated in FIGS. 9a-c, the feeder bar 42 has one opening 42c in the inclined face 42b which divides into two feed tubes 42e although the key 42 may have any number of openings and feed tubes. In applications where the envelope blank B is disposed over the feeder bar 42, the orifices 42a and the feed tube opening 42c may be connected to the transport side of the air delivery assembly 90 in order to feed vacuum to the feeder bar 42 and retain the envelope blank B to the feeder bar surface 42f. Conversely, in applications where the cutting die 14 is disposed over the feeder bar 42, the feeder bar opening 42c is oriented so that it communicates with the vacuum side of the air delivery assembly 90, thereby retaining the panel P adjacent the feeder bar surface 42f.

THE AIR DELIVERY ASSEMBLY

In accordance with certain objects of the invention, a novel air delivery assembly 90 is provided for supplying vacuum or compressed air to the die holder 16. The air delivery assembly 90 comprises a transport assembly 92 and a vacuum assembly 94. The transport assembly 92 is adapted to feed vacuum to the die holder 16 in order to retain the envelope blank B adjacent to the die holder 16 and "transport" the envelope blank B as the holder 16 rotates through the cutting operation. The vacuum assembly 94, in turn, is adapted to feed vacuum to the die holder 16 in order to retain the panel P cut from the envelope blank B adjacent to the die holder 16 until a predetermined position is reached wherein the panel P is released from the die holder 16. At predetermined positions, the transport and vacuum assemblies 92, 94 may feed compressed air to the die holder 16 in order to release the envelope blank B and the panel P, respectively.

In accordance with one aspect of the invention, the air delivery assembly comprises a stationary plate disposed at least at one end of the die holder and defining a groove member for selectively supplying vacuum and/or air. The die holder is operatively connected to the stationary plate so that a supply of vacuum or air is selectively supplied at the surface orifices of the die holder when rotation of the die holder aligns the longitudinal feed tubes with the groove member.

In the embodiment illustrated FIGS. 1-2, the right and left sides of the die holder 16 are designated as the vacuum and transport sides, respectively. The same reference numeral with the suffix "v" and "t" will be used to denote the similar

components of the air delivery assembly 90 which are located in both the transport assembly 92 and the vacuum assembly 94, respectively.

THE VACUUM ASSEMBLY

Referring to the vacuum assembly 94 in FIGS. 1 and 7, it will be seen that the vacuum assembly 94 comprises a rotary connector plate 95v which is attached to and rotate in unison with the die holder 16, a stationary plate 110v fixed to the panel cutting machine 10, and an interface seal 105v which is disposed between the connector plate 95v and the stationary plate 110v to form a substantially air-tight seal.

The connector plate 95v has an interior side 96v adapted for matedly engaging the vacuum side 62v of the die holder 16 and an exterior side 97v adapted for engaging the interface seal 105v. The connector plate 95v has a central bore 101v for receiving the drive shaft 12. Since the inclined cover plate side 50v and key faces 42b and 44b project outwardly from the vacuum side 62v of the die holder 16, the interior side 96v of the connector plate 95v has inclined insets 98v, 99v, adapted to receive and engage the cover plate 50 and the keys 42, 44, respectively. When the cover plate 50 and the keys 42, 44 are attached to the cylindrical sections 22, 24 and the screws 52 are tightened, the force exerted by the inclined faces 50v, 42b and 44b on the inclined insets 98v and 99v assist in forming a substantially air-tight seal.

In order to communicate vacuum and compressed air to the die holder 16, the connector plate 95v has a plurality of holes 102v corresponding to any feed tubes, including for example feed tubes 80, 82, 42c, 44c, in the die holder 16. As shown in FIG. 1, it is preferable to have a plastic or rubber gasket seal 103v disposed between the holes 102v and the feed tubes 80, 82, 42c, 44c to insure that an air-tight seal is created between the metal die holder 16 and connector plate 95v.

Once the connector plate 95v is properly aligned with the die holder side 62, the connector plate 95v and the die holder side 62 are attached together using screws 100v. It will be appreciated that the die holder 16 and the connector plate 95v rotate in unison together.

Although any suitable metals or other materials may be used, it will be appreciated that the connector plate 95 and the stationary plate 110 are typically machined from aluminum so that direct contact between the rotating connector plate 95 and the stationary plate 110 is abrasive. In order to reduce such abrasion, the interface seal 105v is disposed between the connector plate 95 and the stationary plate 110. The interface seal 105v has a plurality of openings generally designated as 106v in FIG. 1 which correspond with the holes 102v in the connector plate 95v. The interface seal 105v may be attached to either the connector plate 95v or the stationary plate 110v although in the illustrated embodiment, the interface seal 105v is attached to the connector plate 95v using screws 100v. Although any suitable abrasion and temperature resistant material may be used, it has been found that manufacturing the interface seal 105v from a plastic known under the trade name Rulon manufactured by Furon Advanced Polymers is satisfactory. The plastic interface seal 105v may be easily replaced if it wears out so that the physical integrity of the expensive machined connector plate 95v may be maintained.

The stationary plate 110v has an interior side 111v adapted to engage the interface seal 105v. The interior side 111v defines a vacuum groove 112v which is in communication with a vacuum source (not shown) via vacuum hose

114v, an air supply groove 116v which is in communication with a compressed air source (not shown) via air hose 118v, and a central bore 120v adapted to rotatably receive the drive shaft 12.

As the connector plate 95v rotates relative to the stationary plate 110, the connector plate holes 102v rotate and sequentially communicate with the vacuum and air grooves 112v, 116v. When the connector plate openings 102v and thus, the corresponding feed tubes 80, 82, 42c, 44c, in the die holder 16 are in communication with the vacuum groove 112v, the vacuum source is supplied to the corresponding orifices in communication with the feed tubes. Similarly, when the openings 102v are in communication with the air supply groove 116v, compressed air is supplied to the corresponding orifices in the surface 21 of die holder 16. Thus, it will be appreciated that extremely precise timing of the vacuum and compressed air may be supplied to the die holder 16 by adjusting the configuration and position of the vacuum groove 112v and the air groove 116v.

Referring to FIG. 6, it will be appreciated that the cutting die 14 will be disposed along the periphery of the die holder 16. In order for the vacuum assembly 94 to feed vacuum or compressed air to the die opening 20 defined by the cutting edge 18, the operator selects the specific feed tubes which correspond with the orifices within the opening 20. The vacuum side of these feed tubes are left open so that they may communicate with the vacuum assembly 94 and the panel P cut by the cutting die 14 may be retained. On the other hand, the other feed tubes which do not communicate with the cutting die opening 20 or the panel P are sealed so that they do not communicate with the vacuum assembly 94. Any feed tube in the die holder 16 may be sealed at the vacuum side 62v of the die holder or at the corresponding connector plate holes 102v using any appropriate method including, for example, plugs, tape or the like.

As the die holder 16 and the connector plate 95v rotate relative to the stationary plate 110v, the open feed tubes sequentially communicate with the vacuum groove 112v and the air groove 116v. When the appropriate feed tube communicates with the vacuum groove 112v, vacuum is supplied to the surface 21 of the die holder 16 and the cutting die 14 so as to retain the panel P cut from the blank B within the die opening 20. Similarly, compressed air is supplied to the surface 21 of the die holder 16 and the cutting die 14 so as to blow the panel P from the cutting die 14 when the open feed tubes communicate with the air groove 114t.

THE TRANSPORT ASSEMBLY

The transport assembly 92, illustrated in FIGS. 1 and 5, is similar to the vacuum assembly 94 except that it is used to retain the envelope blank B instead of the panel P adjacent to the die holder surface 21. The transport assembly comprises a connector plate 95t, an interface plate 105t and a stationary plate 111t.

The connector plate 95t has an interior face adapted to matedly engage the transport side of the die holder. In the embodiment illustrated in FIGS. 1 and 5, the inclined faces of the cover plate 50t and the transport key 45a project outwardly from the transport side 62t of the die holder 16 so that the connector plate 95t has a corresponding inset 98t for secure engagement therewith. In order to feed vacuum and compressed air to the die holder 16, the connector plate 95t has a plurality of holes 102t which correspond with the feed tubes 45b, 80t, and 82t disposed on the transport face 62t of the die holder 16. The exact number and position of feed tubes around the periphery of the die holder 16 will vary in

each particular application. Like the vacuum assembly 94, it is preferred that a plastic or rubber gasket seal 103t be disposed between the holes 102t and the feed tubes 82 to insure an air-tight seal. Another O-ring 103t may also be disposed between the connector plate 95t and the other feed tubes (in the lower section 24) which are not being used. After the connector plate 95t is attached to the die holder 16 using screws 100t, the connector plate 95t and die holder 16 will rotate in unison.

The interface seal 105t, disposed between the connector plate 95t and the stationary die 110t, is identical with the interface seal 105v associated with the vacuum assembly except that its physical configuration will correspond with the holes 102t and bore 101t.

The stationary plate 110t is similar to the stationary plate 110v in that it has a vacuum groove 112t and air groove 116t. The orientation and physical size of the vacuum and air grooves 112t and 116t may be different to accommodate the timing differences associated with the transport assemblies' goal of retaining the envelope blank B as compared with the vacuum assemblies' goal of retaining the panel P.

During the cutting operation, it will be appreciated that the envelope blank B will be disposed adjacent the periphery of the die holder 16 so that certain orifices and the corresponding feed tubes will communicate with the envelope blank B. In order for the transport assembly 92 to feed vacuum or compressed air to the envelope blank B, the operator preselects the orifices and feed tubes which communicate with the envelope blank B. The transport side of feed tubes which communicate with the envelope blank B are left open. The other feed tubes which do not communicate with the envelope blank B are sealed.

As the die holder 16 and the connector plate 95t rotate, the open feed tubes communicate with the vacuum groove 112t and the air groove 116t in the stationary plate 110t. When the connector plate openings 102v are aligned and communicate with the vacuum groove 112t, vacuum is supplied to the surface 21 of the die holder 16 so as to retain the envelope blank B in the desired position. Similarly, compressed air is supplied to the surface 21 of the die holder 16 so as to release the envelope blank B from the die holder 16. Since the feed tubes which do not communicate with the envelope blank B are sealed the transport assembly does not feed vacuum or compressed air thereto.

Since the vacuum assembly 94 acts to control the release of the panel P cut from the envelope blank B whereas the transport assembly 92 acts to control the release of the envelope blank B, it will be appreciated that the configuration and position of the vacuum and air grooves 112, 116 in the vacuum and transport assemblies 94, 92 will vary with the position and size of the die cutter 10 and the size and position of the envelope blank B. Similarly, although the air delivery assembly 90 has been described with respect to the illustrated embodiments of the feed tubes associated with the illustrated die holder 16, the number, configuration and radially position of the feed tubes may be varied as long as the feed tubes are capable of communicating with the vacuum and air grooves in the air delivery assembly during the die holder's rotation.

OPERATION

In operation, the rotary cutter 10 is adapted to be installed on a conventional drive shaft 12. Typically, the cylindrical sections 22 and 24 may be disposed so that the bore 28 engages the shaft 12 and the screws 26 are tightened to attach the sections 22 and 24 about the shaft 12. The cutting

die 14 and the keys may be attached to the cylindrical sections 22 and 24 as previously explained.

Although any type of conveyor assembly may be used which moves the envelope blanks B in serial order to the rotary cutter 10 which cuts out the panels P, in the illustrated embodiment, the conveyor system comprises a cylinder R which delivers the uncut envelope blank B to the rotary cutter 10 and a cylinder L which transports the cut envelope blank B away from the rotary cutter 10. In the embodiments illustrated in FIGS. 11-12, cylinders L and R are rotating in a clockwise direction and the rotary cutter 10 is rotating in a counter clockwise direction, although the rotation may be varied depending upon the particular application. FIGS. 11a-c illustrate the operation of the transport assembly 92 and FIGS. 12a-c illustrate the operation of the vacuum assembly 94 as viewed along the longitudinal axis 30 and from left (transport) side of the die cutter 10 as shown in FIG. 2.

Turning first to FIGS. 11a-c which schematically illustrate the operation of the transport assembly 92, it will be seen that the top portion of the stationary plate 110t contains the vacuum groove 112t and the air groove 116t depicted by the broken lines. The transfer cylinder R delivers the envelope blank B to the transfer bar 45 at transfer point W between the die holder 16 and cylinder R. The transport bar 45 has orifices 45c which engage the leading edge of the envelope blank B and feed tubes 45b which communicate with the transport side 62t of the die holder 16 and the transport assembly 92. When the feed tubes 45b communicate with the vacuum groove 112t, vacuum is feed to the orifices 45c so that the transport bar 45 retains the envelope blank B adjacent to the die holder surface 21. It will be appreciated that other feed tubes of the die holder 16, generally designated as F in FIG. 11, will also communicate with the transport assembly 92 as the die holder rotates in the counterclockwise direction. Like the feed tube 45b and orifices 45c in the transport bar 45, each feed tube F and the corresponding orifices will operate to retain the entire envelope blank B adjacent to the die holder surface 21. It will be appreciated that the feed tubes F and the corresponding orifices which communicate with the transport assembly 92 are subjacent the envelope blank B and do not communicate with the panel P which is cut from the blank B. Any feed tubes which communicate with the panel P are sealed to the transport assembly 92.

As the die holder 16 rotates, the feed tube 45b and the envelope blank B pass between the cutting bar 122 and the die holder 16 (point X) but since the cutting die 14 is not present, the envelope blank B passes through without being cut. The feed tube 45b continues to communicate with the vacuum groove 112t until the end of the vacuum groove 112t at which point the envelope blank B is ready to be transferred to the transfer cylinder L as shown in FIG. 11b at point Y. When the feed tube 45b exits the vacuum groove 112t and enters into the air groove 116t, the vacuum to the feed tube 45b and corresponding orifices 45c is terminated and compressed air is fed to thereto which acts to release the envelope blank B. Simultaneously, the transfer cylinder L applies a vacuum which transfers the envelope blank B from the die holder 16 to cylinder L.

The transport bar 45 continues to rotate to the transfer cylinder R to obtain the next successive envelope blank B at point W as shown in FIG. 11c.

Turning next to FIGS. 12a-c which schematically illustrate the operation of the vacuum assembly 94, it will be seen that the vacuum groove 112v and the air groove 116v are

disposed in the left portion of the die holder 16. When the transfer cylinder R first delivers the envelope blank B to the transfer point W between the die holder 16 and cylinder R, only the transport bar 45 engages the envelope blank B as described above. The feed tubes 45b associated with the transport bar 45 and the feed tubes F which communicate with the envelope blank B are sealed so that they do not communicate with the vacuum assembly 94. On the other hand, the feed tubes, generally depicted as F2, which are subjacent the opening 20 of the cutting die 14 are in communication with the vacuum assembly 94.

As the die holder 16 rotates, the feed tubes F2 and the cutting die 14 engage the envelope blank B at point W. The feed tubes F2 remain inactive because they are not in communication with the vacuum or air grooves 112v, 116v of the vacuum assembly 94.

As shown in FIG. 12b, when the envelope blank B passes between the cutting bar 122 and the cutting die 14 at point X, the panel P is cut from the envelope blank B. The illustrated cutting bar 122 is a stationary bar but those skilled in the art that other embodiments may be used, including, for example, rotary cutting bars or anvils, square or circular cutting bars and the like. At point X, the feed tubes F2 communicate with the vacuum groove 112v. The vacuum source feeds vacuum to the feed tubes F2 and the corresponding orifices which are within the opening 20 of the cutting die 14. The vacuum retains the panel P adjacent the outer surface 21 of the die holder 16.

As the die holder 16 continues to rotate, the transport bar 45 reaches the transfer point Y with cylinder L and the envelope blank B is transferred to cylinder L. The cutting die 14 subsequently reaches the transfer point Y, but the feed tubes F2 remain in communication with the vacuum groove 112v so that the panel P is not released from the die holder 16.

As shown in FIG. 12c, the die holder 16 continues to rotate until the cutting die 14 reaches point Z wherein the feed tubes F2 leave the vacuum groove 112v and enter the air groove 116v. The air groove 116v feeds compressed air to the feed tubes F2 which subsequently releases the panel P into a scrap collection bin for later disposal.

In order to assist the disassembly of die holder 16 from the drive shaft 12, the cylindrical section 22 may have a plurality of holes 125 which cooperate with a screw handle 126. When the screw handle 126 is screwed into the holes 125, the tip 126a of the handle 126 creates space between the cylindrical sections 22, 24 and the drive shaft 12 which enables the operator to easily disengage the die holder 16 therefrom. The handle tip 126a may be made from a relatively soft metal such as brass or the like which will not damage the drive shaft 12. The screw handle 126 may also be used to carry the die holder 16.

Instead of a mechanical clamp assembly as illustrated in FIGS. 1-11, other embodiments of a rotary cutting apparatus utilizing magnetic clamp assemblies 200 to retain and hold the cutting die 14 adjacent to the die holder surface 21 are illustrated in FIGS. 16-27. FIGS. 13a and 13b illustrate embodiments of cutting dies 202, 204 which are adapted to be used in conjunction with the magnetic die holder 216.

In the embodiment illustrated in FIGS. 17-25, a plurality of recesses 218 are formed in the die holder 216 for receiving individual individual magnets 220. In the embodiment illustrated in FIGS. 26-27, the die holder 316 has a plurality of longitudinally extending grooves 318, each groove 318 being adapted to receive an insert 320. Each insert 320 has a plurality of recesses 322 for receiving

individual magnets 220. It has been found that it is easier to manufacture and machine the recesses 322 in the insert, rather than the relatively large and bulky die holder, and subsequently install the insert 320 in the die holder 316.

As shown in FIGS. 20-22, the outer surface of the magnets 218a are flush with die holder surface 21. Although the dimensions of the magnets may be varied depending upon the application, it is preferred that the width be from about 0.125 to about 0.25 inches, the length from 0.375 to about 0.75 inches, and the height from about 0.175 to about 0.25 inches.

As soon as the cutting die 14 is brought near the die holder surface 21, the magnets 220 attract the thin metal cutting die 14. The cutting die 14 is, thus, magnetically retained adjacent to the surface 21 of the die holder 16. The magnetic force will flatten the entire area of the cutting die 14 against the die holder surface 21 so that there is no slack present between the die holder surface 21 and the cutting die 14. The cutting die 14 must be properly positioned and orientated so that it properly cuts the envelope blanks B.

A plurality of air orifices 240 are disposed in the die holder surface to retain the envelope blank B and the panel P adjacent to the die holder surface 21. The other portions of the die holder surface which do not receive the blank B or the panel P do not require orifices 240. The air orifices 240 are in radial communication with the plurality of corresponding air feed tubes 80. The feed tubes 80 and the corresponding orifices 240 may be connected to the novel vacuum and compressed air delivery system described above or to a conventional source of vacuum and compressed air (not shown).

It is generally preferred to maximize the number and distribution of the orifices 240 while minimizing the number and distribution of the expensive magnets 220. Thus, it is preferred that at least some orifices 240 be disposed between substantially all of the adjacent magnets 220 in order to maximize the distribution and effect of the orifices 240, thereby permitting the cutting die 14 to be placed anywhere on the die holder surface 21 and the panel P cut from the blank B to be retained during the cutting operation. It will be appreciated that any number of orifices may be disposed between adjacent magnets.

In the embodiment illustrated in FIGS. 17-19, 23 and 25, the recesses 218 and the magnets 220 are disposed in parallel, horizontal rows 230 and columns 232 such that the longitudinal axis of the columns 232 in each adjacent row 230 are aligned with each other. In the embodiment illustrated in FIG. 21, the recesses 218 and magnets 220 are disposed in parallel, horizontal rows 230 and columns 234 such that the longitudinal axis of columns 234 in each adjacent row 230 are offset relative to each other. Substantially all of the rows 230 have orifices 240 disposed between substantially all of the adjacent magnets 220. Similarly, it is preferred that the die holder 216 have alternating rows 230 of magnets 220 and orifices 240 and alternating columns 232, 234 of magnets 220 and orifices 240. Other arrangements of magnets 220 and orifices 240 will be known to those skilled in the art.

It should now be appreciated that the illustrated embodiments maximize the ability of the die opening 20 to communicate with orifices 240 wherever the cutting die 14 is disposed on the die holder surface 21. In contrast, many conventional magnetic die holders which have alternating rows of magnets and orifices or alternating columns of magnets and orifices tend to limit the placement of the cutting die 14 because the die holder may have an insuffi-

cient number orifices in the vicinity of the die opening **20** for retaining the panel **P**.

In order to increase the magnetic effect of the magnets **220**, the individual magnets **220** may have a magnetic wire **250** extending between the individual magnets **220**. In FIGS. **22** and **25**, for example, each row of magnets **220** has a centrally disposed wire **250** extending along the axis **30** and connecting the individual magnets **220** in the respective row **230**. It is believed that the wire **250** increases the overall magnetic effect of the magnets **220**. Referring to FIG. **22**, it will be seen that the orifices **240** which are in radial communication with the feed tubes **80** are disposed so that they do not interfere with the centrally disposed wire **250**. Alternatively, the wire **250** may be offset from the center of the magnets **240**.

The cutting die **14** may be removed from the die holder **216** by exerting a significant tangential force thereon or by reducing the local induction of the magnets **240**. Unfortunately, the cutting operation may create sufficient tangential forces including, for example, the forces created by the rotation of the die holder **216**, which may displace a cutting die **14** of the type illustrated in FIG. **16b** or cause the die **14** to slip such that it is improperly orientated relative to the blank **B**. In order to prevent such displacement or slippage, the die holder **216** preferably has at least one relatively thin slot **252** which is adapted to receive the leading end **202a** of the cutting die **202** illustrated in FIG. **16a**. Although the illustrated embodiment of the slot **252** extends along the longitudinal axis **30**, it may also be angularly displaced relative to the longitudinal axis **30**. The engagement between the leading end **202a** and the slot **252** prevents the cutting die **202** from slipping or becoming angularly displaced during the cutting operation. The slot **252** also eases assembly, making it possible to easily and readily mark and obtain the proper position of the die **202** on the die holder surface **21** without the need for cumbersome tools required in many conventional mechanical clamping assemblies. The slot **252** may be disposed anywhere along the periphery of the die holder **216**. In another embodiment, the die holder **216** may have two slots **252** for receiving a cutting die **14** of type illustrated in FIG. **16**—one slot receives the leading end **14a** and the second slot receives the trailing end **14b**. The width of the slot **252** may vary but it has been found that a width from about 0.004 to about 0.1 inch is sufficient to receive the cutting die end.

FIGS. **28–32** illustrate a novel valve assembly **260** for selectively controlling the flow of air to each of the feed tubes **80** from a source of vacuum or compressed air in contrast to conventional methods which use plastic plugs and tape which are easily removed or lost. The illustrated embodiment of the end plate **95** is a disc shaped body having front and back sides **97, 96** and an end peripheral face **262**. The end plate **95** has a plurality of longitudinally extending holes **102** connecting the front and back sides **97, 96** and which are adapted to align with the feed tubes **80** disposed on the die holder **216**. Each hole **102** has a corresponding axially extending valve hole **264** adapted to receive the valve member **260**.

The valve member **260** has a bore **266** which is capable of selectively aligning with the corresponding end plate hole **102**. When the valve bore **266** is aligned with the end plate hole **102** as shown in FIG. **30**, the bore **266** and the hole **102** cooperate to feed vacuum or air through the end plate **95**. When the valve member **260** is rotated **90** degrees as shown in FIG. **31**, the valve bore **264** is perpendicular to the end plate hole **102** and the valve member **260** seals the end plate hole **102**.

In accordance with certain objects of the invention, a preferred embodiment provides a valve member **260** which is capable of selective and controlled rotation between a first closed position wherein the valve member **260** prevents flow through the end plate hole **102** (as shown in FIG. **31**) and a second, open position wherein the valve member **260** permits flow through the end plate hole **102** (as shown in FIG. **30**). Referring to FIGS. **30–32**, the valve member **260** has a cam surface **270** which engages a pin **268** disposed in the valve hole. The shape of the cam surface **270** is such that the valve member **260** may rotate only between the closed and open positions. It will be appreciated that the valve member **260** insures that the individual end plate hole **102** is sealed by defining easily recognizable opened and closed positions. In the illustrated embodiment, the cam surface **270** has a curved portion **270a** connecting two substantially perpendicular sides **270b, 270c** which limit the rotation of the valve member. Although the head of the valve member **260** has a hex head be adapted to receive an allen driver, the head may be adapted to receive any type of manual turning device including, for example, a screw driver and the like.

The valve member **260** also has a seal member **280** which provides a relatively air-tight seal between the valve member **260** and the end plate **95**. Although the illustrated embodiment of the valve member **260** is disposed in the end plate **95**, it will be appreciated that the valve member **260** may also be disposed in the die holder **216** such that it communicates with the feed tube **80**.

Thus, it will be seen that a die cutting apparatus and related cutting devices have been provided which attain the aforementioned objects. Although the structure and operation of the cutting die apparatus has been described in connection with the cutting of window panel from an envelope blank, it is not intended that the invention be limited only to such operations. Various additional modifications of the described embodiments of the invention specifically illustrated and described herein will be apparent to those skilled in the art, particularly in light of the teachings of this invention. The invention may be utilized in the cutting of any pattern from any relatively thin and flexible sheet-like material blank, including, for example, paper, cloth or plastic materials and labels, sanitary napkins, and the like. The invention is also applicable in butt-cutting operations wherein one blank is cut from a stack of multiple adjacent blanks, and may be used with solid or flexible dies. The invention also permits the selective control of the transport, retention, and release of the separate blank and pattern members during the rotation of the die holder. It is intended that the invention cover all modifications and embodiments which fall within the spirit and scope of the invention. Thus, while preferred embodiments of the present invention have been disclosed, it will be appreciated that it is not limited thereto but may be otherwise embodied within the scope of the following claims.

We claim as our invention:

1. A rotary holder assembly adapted to carry a cutting die having edges and opposing sides for cutting a pattern from at least one material blank, the holder assembly comprising:

a cylindrical die holder adapted to be mounted on a drive shaft for rotating about an axis, the die holder having an outer surface and a plurality of orifices disposed on the outer surface wherein the orifices are in communication with a source of vacuum, at a first time, or air, at a second time, thereby selectively supplying the vacuum or the air to the surface;

the die holder having at least one groove for receiving a holding key which cooperate to clamp one of the edges

of the cutting die therebetween for securing the cutting die to the holder; and

the holding key having an outer surface, a longitudinally directed feed tube, and a plurality of orifices disposed on the key outer surface and communicating with the feed tube for supplying the vacuum or the air to the surface of the key.

2. The assembly as set forth in claim 1 wherein at least one of the holding keys is a transport key having means for engaging and retaining the leading edge of the envelope blank adjacent to the outer surface of the key as the die holder rotates.

3. The assembly as set forth in claim 1 wherein at least one of the holding keys is a feeder key having means for engaging and retaining the panel cut from the blank adjacent to the outer surface of the key as the die holder rotates.

4. The assembly as set forth in claim 1 wherein the holding key has means to engage two adjacent blanks and to retain one of the blanks after the second blank is cut by the cutting die.

5. A rotary holder assembly adapted to carry a cutting die for cutting a pattern from a material blank, the assembly comprising:

a cylindrical die holder for rotating about an axis, the die holder having an outer surface and a plurality of orifices disposed on the outer surface, the plurality of orifices supplying to the surface vacuum at a first time or air at a second time, the orifices being in radial communication with a corresponding longitudinally directed feed tube; and

a valve assembly for controlling the flow of air through each of the feed tubes comprising a valve hole in radial communication with said corresponding feed tube and adapted for receiving a valve member, the valve member being rotatable within the hole between open and closed positions wherein the valve member, having a cam surface that engages with a pin in the valve hole, permits flow through the feed tube in the open position and prevents flow through the feed tube in the closed position.

6. The assembly as set forth in claim 5 wherein the valve member has a bore capable of selectively aligning with the feed tube wherein the bore aligns with the feed tube when the valve member is positioned to the open position and wherein the bore does not align with the feed tube when the valve member is positioned to the closed position.

7. The assembly of claim 1 wherein the cutting die is at least partly made from a magnetically permeable material and the die holder includes a magnetic member disposed about the outer surface for retaining the cutting die.

8. The assembly of claim 6 wherein the cutting die is at least partly made from a magnetically permeable material and the die holder includes a magnetic member disposed about the outer surface for retaining the cutting die.

9. A method for retaining and releasing a material blank and a pattern cut from the material blank, the material blank and the pattern being carried by a rotating die holder, the die holder having an outer surface and a plurality of orifice groups disposed in the outer surface, each orifice group being in communication with a feed tube having a transport end and a vacuum end, the method comprising:

closing the vacuum end and opening the transport end of each feed tube that corresponds to an orifice group in communication with the pattern;

closing the transport end and opening the vacuum end of each feed tube that corresponds to an orifice group in

communication with at least a portion of the blank other than the pattern;

supplying vacuum to the transport ends of the feed tubes at a first predetermined period of time during the rotation of the die holder; and

supplying vacuum to the vacuum ends of the feed tubes at a second predetermined period of time during the rotation of the die holder, wherein the ends of the feed tubes are opened and closed using a plurality of valve assemblies, each valve assembly comprising, in communication with an end of a corresponding one of the feed tubes, a valve member rotatable between an open position and a closed position wherein the valve means permits flow through the end of the corresponding feed tube in the open position and prevents the flow through the end of the corresponding feed tube in the closed position.

10. A method for retaining and releasing a material blank and a pattern cut from the material blank, the material blank and the pattern being carried by a rotating die holder, the die holder having an outer surface and a plurality of orifice groups disposed in the outer surface, each orifice group being in communication with a corresponding feed tube having a transport end and a vacuum end, the method comprising the steps of:

closing the vacuum end and opening the transport end of each feed tube that corresponds to an orifice group in communication with the pattern;

closing the transport end and opening the vacuum end of each feed tube that corresponds to an orifice group in communication with at least a portion of the blank other than the pattern;

supplying air to the transport ends of the feed tubes at a first predetermined period of time during the rotation of the die holder; and

supplying air to the vacuum ends of the feed tubes at a second predetermined period of time during the rotation of the die holder, wherein the ends of the feed tubes are opened and closed using a plurality of valve assemblies, each valve assembly comprising, in communication with an end of a corresponding one of the feed tubes, a valve member rotatable between an open position and a closed position wherein the valve member permits flow through the end of the corresponding feed tube in the open position and prevents flow through the end of the corresponding feed tube in the closed position.

11. A method for retaining and releasing a material blank and a pattern cut from the material blank, the material blank and the pattern being carried by a rotating die holder, the die holder having an outer surface and a plurality of orifice groups disposed in the outer surface, each orifice group being in communication with a corresponding feed tube having a transport end and a vacuum end, the method comprising:

closing the vacuum end and opening the transport end of each feed tube that corresponds to an orifice group in communication with the pattern;

closing the transport end and opening the vacuum end of each feed tube that corresponds to an orifice group in communication with at least a portion of the blank other than the pattern;

supplying vacuum to the transport ends of the feed tubes at a first predetermined period of time during the rotation of the die holder;

supplying vacuum to the vacuum ends of the feed tubes at a second predetermined period of time during the rotation of the die holder;

21

supplying air to the transport ends of the feed tubes at a third predetermined period of time during the rotation of the die holder; and

supplying air to the vacuum ends of the feed tubes at a fourth predetermined period of time during the rotation of the die holder.

12. The method of claim 11 wherein the ends of the feed tubes are opened and closed using a plurality of valve assemblies, each valve assembly comprising, in communication with an end of a corresponding one of the feed tubes, a valve member rotatable between an open position and a closed position wherein the valve member permits flow through the end the corresponding feed tube in the open position and prevents flow through the end of the corresponding feed tube in the closed position.

13. A rotary holder assembly adapted to carry a cutting die for cutting a panel from a material blank, the rotary holder assembly comprising:

a cylindrical die holder adapted to be mounted on a drive shaft for rotating about an axis, the die holder having an outer surface, a vacuum end and a transport end; a plurality of orifices disposed on the outer surface of the die holder;

a plurality of feed tubes extending from the vacuum end of the die holder to the transport end of the die holder, each of the feeds being in communication with one or more of the orifices and having a vacuum end at the vacuum end of the die holder and a transport end at the transport end of the die holder;

selecting means for selecting a first group of orifices and a second group of orifices from the plurality of orifices, the selecting means comprising opening and closing means for selectively opening and closing the transport and vacuum ends of the feed tubes, whereby the opening and closing means is used to open the vacuum end and close the transport end of each feed tube of a first set of feed tubes and to close the vacuum end and open the transport end of each feed tube of a second set of feed tubes so that the first group of orifices comprises the orifices in communication with the first set of feed tubes that communicate with the vacuum side and not the transport side of the die holder and the second group of orifices comprises the orifice in communication with the second set of feed tubes that communicate with the transport side and not the vacuum side of the die holder; and

vacuum delivery means for delivering means to the orifices in the first group of orifices at a first period of time during the rotation of the die holder and vacuum to the orifices in the second group of orifices at a second period of time during the rotation of the die holder;

wherein the opening and closing means comprises a plurality of valve assemblies, each comprising, in communication with a corresponding one of the feed tubes, a valve hole adapted for receiving a valve member, the valve member rotatable within the valve hole between an open position and a closed position wherein the valve member permits flow through the corresponding feed tube in the open position and prevents flow through the corresponding feed tube in the closed position.

14. The assembly of claim 13 further comprising:

a transport end plate mounted to the transport end of the die holder;

and a vacuum end plate mounted to the vacuum end of the die holder and having a peripheral face, wherein the valve holes of valve assemblies for closing the trans-

22

port ends of the feed tubes are located within the transport end plate and the valve holes of valve assemblies for closing the vacuum ends of the feed tubes are located within the vacuum end plate.

15. The assembly of claim 14 wherein:

the transport end plate has a peripheral face defining a plurality of orifices and each of the valve holes within the transport end plate communicates with a corresponding one of the plurality of the transport end plate orifices; and

the vacuum end plate has a peripheral face defining a plurality of orifices and each of the valve holes within the vacuum end plate communicates with a corresponding one of the plurality of the vacuum end plate orifices, whereby the valve members within the valve holes are accessible via their corresponding end plate orifices.

16. A rotary holder assembly adapted to carry a cutting die for cutting a panel from a material blank, the rotary holder assembly comprising:

a cylindrical die holder adapted to be mounted on a drive shaft for rotating about an axis, the die holder having an outer surface;

a plurality of orifices disposed on the outer surface of the die holder;

selecting means for selecting a first group of orifices and a second group of orifices from the plurality of orifices; vacuum delivery means for delivering vacuum to the first group of orifices at a first period of time during the rotation of the die holder and vacuum to the second group of orifices at a second period of time during the rotation of the die holder; and

air delivery means for delivering air to the first group of orifices at a third period of time during the rotation of the die holder and air to the second group of orifices at a fourth period of time during the rotation of the die holder.

17. The assembly of claim 10 wherein:

the die holder has a vacuum end and a transport end; the first group of orifices is in communication with a first set of one or more feed tubes extending from the vacuum end of the die holder to the transport end of the die holder;

the second group of orifices is in communication with a second set of one or more feed tubes extending from the vacuum end of the die holder to the transport end of the die holder;

each feed tube is in communication with one or more orifices in the plurality of orifices and has a vacuum opening on the vacuum end of the die holder and a transport opening on the transport end of the die holder; and

the selecting means includes opening and closing means for selectively opening and closing the transport and vacuum ends of the feed tubes, whereby the opening and closing means can be used to open the vacuum end and close the transport end of each feed tube of the first set of feed tubes and to close the vacuum end and open the transport end of each feed tube of the second set of feed tubes so that the first group of orifices comprises the orifices in communication with the first set of feed tubes that communicate with the vacuum side and not the transport side of the die holder and the second group of orifices comprises the orifices in communication with the second set of feed tubes that communicate with the transport side and not the vacuum side of the die holder.

23

18. The assembly of claim 17 wherein the opening and closing means comprises a plurality of valve assemblies, each valve assembly comprising, in communication with an end of a corresponding one of the feed tubes, a valve member rotatably between an open position and a closed position wherein the valve member permits flow through the end the corresponding feed tube in the open position and prevents flow through the end of the corresponding feed tube in the closed position.

19. The assembly of claim 17 wherein the vacuum delivery means comprises:

a first stationary plate disposed at the vacuum end of the die holder and defining a first vacuum groove sized and located for supplying vacuum at the first period of time, so that when rotation of the die holder aligns the vacuum end of a feed tube in the first set of feed tubes with the first vacuum groove, vacuum is supplied to the one or more orifices in communication with the feed tube aligned with the first vacuum groove; and

a second stationary plate disposed at the transport end of the die holder and defining a second vacuum groove sized and located for supplying vacuum at the second period of time, so that when rotation of the die holder aligns the transport end of a feed tube in the second set of feed tubes with the second vacuum groove, vacuum is supplied to the one or more orifices in communication with the feed tube aligned with the second vacuum groove.

20. The assembly of claim 19 wherein the air delivery means comprises:

a first air groove defined by the first stationary plate and sized and located for supplying air at the third period of time, so that when rotation of the die holder aligns the vacuum end of a feed tube in the first set of feed tubes with the first air groove, air is supplied to the one or more orifices in communication with the feed tube aligned with the first air groove; and

a second air groove defined by the second stationary plate and sized and located for supplying air at the fourth period of time, so that when rotation of the die holder aligns the transport end of a feed tube in the second set of feed tubes with the second air groove, air is supplied to the one or more orifices in communication with the feed tube aligned with the second air groove.

21. A rotary holder assembly adapted to carry a cutting die for cutting a panel from a material blank, the rotary holder assembly comprising:

a cylindrical die holder adapted to be mounted on a drive shaft for rotating about an axis, the die holder having an outer surface, a vacuum end and a transport end; a plurality of orifices disposed on the outer surface of the die holder

a plurality of feed tubes extending from the vacuum end of the die holder to the transport end of the die holder, each of the feed tubes being in communication with one or more of the orifices and having a vacuum end at the vacuum end of the die holder and a transport end at the transport end of the die holder;

selecting means for selecting a first group of orifices and a second group of orifices from the plurality of orifices, the selecting means comprising opening and closing means for selectively opening and closing the transport and vacuum ends of the feed tubes, whereby the opening and closing means is used to open the vacuum end and close the transport end of each feed tube of a first set of feed tubes and to close the vacuum end and open

24

the transport end of each feed tube of a second set of feed tubes so that the first group of orifices comprises the orifices in communication with the first set of feed tubes that communicate with the vacuum side and not the transport side of the die holder and the second group of orifices comprises the orifices in communication with the second set of feed tubes that communicate with the transport side and not the vacuum side of the die holder; and

air delivery means for delivery air to the orifices in the first group of orifices at a first period of time during the rotation of the die holder and air to the orifices in the second group of orifices at a second period of time during the rotation of the die holder.

22. The assembly of claim 21 wherein the first period of time and the second period of time overlap.

23. The assembly of claim 21 wherein the cutting die is at least partly made from a magnetically permeable material and the die holder includes a magnetic member disposed about the outer surface for retaining the cutting die.

24. The assembly of claim 21 wherein the air delivery means comprises:

a first stationary plate disposed at the vacuum end of the die holder and defining a first air groove sized and located for supplying air at the first period of time, so that when rotation of the die holder aligns the vacuum end of a feed tube in the first set of feed tubes with the first air groove, air is supplied to the one or more orifices in communication with the feed tube aligned with the first air groove; and

a second stationary plate disposed at the transport end of the die holder and defining a second air groove sized and located for supplying air at the second period of time, so that when rotation of the die holder aligns the transport end of a feed tube in the second set of feed tubes with the second air groove, air is supplied to the one or more orifices in communication with the feed tube aligned with the second air groove.

25. The assembly of claim 21 wherein the opening and closing means comprises a plurality of valve assemblies, each valve assembly comprising, in communication with an end of a corresponding one of the feed tubes, a valve member rotatable between an open position and a closed position wherein the valve member permits flow through the end of the corresponding feed tube in the open position and prevents flow through the end of the corresponding feed tube in the closed position.

26. The assembly of claim 25 wherein the valve member has a bore that aligns with the corresponding feed tube when the valve member is in the open position and does not align with the corresponding feed tube when the valve member is in the closed position.

27. A rotary holder assembly adapted to carry a cutting die for cutting a panel from a material blank, the rotary holder assembly comprising:

a cylindrical die holder adapted to be mounted on a drive shaft for rotating about an axis, the die holder having an outer surface, a vacuum end and a transport end; a plurality of orifices disposed on the outer surface of the die holder;

a plurality of feed tubes extending from the vacuum end of the die holder to the transport end of the die holder, each of the feed tubes being in communication with one or more of the orifices and having a vacuum end at the vacuum end of the die holder and a transport end at the transport end of the die holder;

25

selecting means for selecting a first group of orifices and a second group of orifices from the plurality of orifices, the selecting means comprising opening and closing means for selectively opening and closing the transport and vacuum ends of the feed tubes, whereby the opening and closing means is used to open the vacuum end and close the transport end of each feed tube of a first set of feed tubes and to close the vacuum end and open the transport end of each feed tube of a second set of feed tubes so that the first group of orifices comprises the orifices in communication with the first set of feed tubes that communicate with the vacuum side and not the transport side of the die holder and the second group of orifices comprises the orifices in communication with the second set of feed tubes that communicate with the transport side and not the vacuum side of the die holder; and

vacuum delivery means for delivering vacuum to the orifices in the first group of orifices at a first period of time during the rotation of the die holder and vacuum to the orifices in the second group of orifices at a second period of time during the rotation of the die holder;

wherein the opening and closing means comprises a plurality of valve assemblies, each valve assembly comprising, in communication with an end of a corresponding one of the feed tubes, a valve member rotatable between an open position and a closed position wherein the valve member permits flow through the end of the corresponding feed tube in the open position and prevents flow through the end of the corresponding feed tube in the closed position.

28. The assembly of claim 27 wherein the valve member has a bore that aligns with the corresponding feed tube when the valve member is in the open position and does not align with the corresponding feed tube when the valve member is in the closed position.

29. The assembly of claim 27 wherein the vacuum delivery means comprises:

a first stationary plate disposed at the vacuum end of the die holder and defining a first vacuum groove sized and located for supplying vacuum at the first period of time, so that when rotation of the die holder aligns the vacuum end of a feed tube in the first set of feed tubes with the first vacuum groove, vacuum is supplied to the one or more orifices in communication with the feed tube aligned with the first vacuum groove; and

a second stationary plate disposed at the transport end of the die holder and defining a second vacuum groove sized and located for supplying vacuum at the second period of time, so that when rotation of the die holder aligns the transport end of a feed tube in the second set of feed tubes with the second vacuum groove, vacuum is supplied to the one or more orifices in communication with the feed tube aligned with the second vacuum groove.

30. The assembly of claim 29 further comprising air delivery means for delivering air to the first group of orifices at a third period of time during the rotation of the die holder and air to the second group of orifices at a fourth period of time during the rotation of the die holder.

31. The assembly of claim 30 wherein the air delivery means comprises:

a first air groove defined by the first stationary plate and sized and located for supplying air at the third period of time, so that when rotation of the die holder aligns

26

the vacuum end of a feed tube in the first set of feed tubes with the first air groove, air is supplied to the one or more orifices in communication with the feed tube aligned with the first air groove; and

a second air groove defined by the second stationary plate and sized and located for supplying air at the fourth period of time, so that when rotation of the die holder aligns the transport end of a feed tube in the second set of feed tubes with the second air groove, air is supplied to the one or more orifices in communication with the feed tube aligned with the second air groove.

32. A rotary holder assembly adapted to carry a cutting die for cutting a panel from a material blank, the rotary holder assembly comprising:

a cylindrical die holder adapted to be mounted on a drive shaft for rotating about an axis, the die holder having an outer surface, a vacuum end and a transport end; a plurality of orifices disposed on the outer surface of the die holder

a plurality of feed tubes extending from the vacuum end of the die holder to the transport end of the die holder, each of the feed tubes being in communication with one or more of the orifices and having a vacuum end at the vacuum end of the die holder and a transport end at the transport end of the die holder;

selecting means for selecting a first group of orifices and a second group of orifices from the plurality of orifices, the selecting means comprising opening and closing means for selectively opening and closing the transport and vacuum ends of the feed tubes, whereby the opening and closing means is used to open the vacuum end and close the transport end of each feed tube of a first set of feed tubes and to close the vacuum end and open the transport end of each feed tube of a second set of feed tubes so that the first group of orifices comprises the orifices in communication with the first set of feed tubes that communicate with the vacuum side and not the transport side of the die holder and the second group of orifices comprises the orifices in communication with the second set of feed tubes that communicate with the transport side and not the vacuum side of the die holder; and

vacuum delivery means for delivering vacuum to the orifices in the first group of orifices at a first period of time during the rotation of the die holder and vacuum to the orifices in the second group of orifices at a second period of time during the rotation of the die holder.

33. The assembly of claim 32 wherein the first period of time and the second period of time overlap.

34. The assembly of claim 32 wherein, when the material blank is adjacent the outer surface of the die holder, the first group of orifices communicates with at least a portion of the panel and the second group of orifices communicates with at least a portion of the material blank other than the panel.

35. The assembly of claim 32 wherein the cutting die is at least partly made from a magnetically permeable material and the die holder includes a magnetic member disposed about the outer surface for retaining the cutting die.

36. The assembly of claim 32 wherein the vacuum delivery means comprises:

a first stationary plate disposed at the vacuum end of the die holder and defining a first vacuum groove sized and located for supplying vacuum at the first period of time, so that when rotation of the die holder aligns the vacuum end of a feed tube in the first set of feed tubes

with the first vacuum groove, vacuum is supplied to the one or more orifices in communication with the feed tube aligned with the first vacuum groove; and

a second stationary plate disposed at the transport end of the die holder and defining a second vacuum groove sized and located for supplying vacuum at the second period of time, so that when rotation of the die holder aligns the transport end of a feed tube in the second set of feed tubes with the second vacuum groove, vacuum is supplied to the one or more orifices in communication with the feed tube aligned with the second vacuum groove.

37. The assembly of claim 36 further comprising an interface seal disposed between the die holder and the first and second stationary plates for minimizing abrasion and friction therebetween.

38. The assembly of claim 36 further comprising air delivery means for delivering air to the first group of orifices at a third period of time during the rotation of the die holder and air to the second group of orifices at a fourth period of time during the rotation of the die holder.

39. The assembly of claim 38 wherein the air delivery means comprises:

a first air groove defined by the first stationary plate and sized and located for supplying air at the third period of time, so that when rotation of the die holder aligns the vacuum end of a feed tube in the first set of feed tubes with the first air groove, air is supplied to the one or more orifices in communication with the feed tube aligned with the first air groove; and

a second air groove defined by the second stationary plate and sized and located for supplying air at the fourth period of time, so that when rotation of the die holder aligns the transport end of a feed tube in the second set of feed tubes with the second air groove, air is supplied to the one or more orifices in communication with the feed tube aligned with the second air groove.

40. The assembly of claim 37 further comprising a plurality of magnets disposed about the outer surface of the die holder.

41. The assembly of claim 40 further comprising an insert and a groove within the surface of the die holder for receiving the insert, the insert having a recess for receiving one or more of the magnets.

42. The assembly of claim 40 wherein the cutting die has a leading edge and the assembly further comprises a slot within the surface of the cutting die for detachably receiving the leading edge of the cutting die.

43. The assembly of claim 40 in which the magnets are disposed in a plurality of columns circumventing the outer surface of the die holder.

44. The assembly of claim 43 in which the magnets in each column are aligned with the magnets in the adjacent columns.

45. The assembly of claim 43 in which the magnets in each column are offset from the magnets in the adjacent columns.

* * * * *