

19



Octrooi Centrum
Nederland

11

1040566

12 C OCTROOI

21 Aanvraagnummer: **1040566**

51 Int.Cl.:
B23P 15/00 (2006.01) **F16G 5/16** (2006.01)

22 Aanvraag ingediend: **24.12.2013**

43 Aanvraag gepubliceerd:
-

73 Octrooihouder(s):
**ROBERT BOSCH GMBH te STUTTGART,
BONDSREPUBLIC DUITSLAND (DE).**

47 Octrooi verleend:
26.06.2015

72 Uitvinder(s):
Johan Vermeer te Tilburg.

45 Octrooischrift uitgegeven:
01.07.2015

74 Gemachtigde:
ir. G.A.J.M. Plevier te Tilburg.

54 **Method for manufacturing a carrier ring suitable for use in a drive belt for a continuously variable transmission.**

57 The disclosure relates to the manufacturing of a carrier ring (32) made from steel for use in a drive belt (3) for a continuously variable transmission, which manufacturing includes the process steps of:

- welding a plate (11) of basic material into the shape of a tube (13),
- separating a ring-shaped section (14) from the tube (13) in a melt cutting process, such as by means of a laser (19),
- annealing the ring-shaped section (14) and
- processing the annealed ring-shaped tube section (14) to form the carrier ring (32), which processing at least includes elongating the annealed ring-shaped tube section (14) by means of a rolling process.

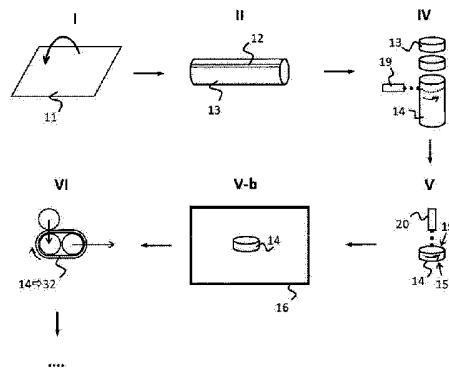

NL C 1040566

Dit octrooi is verleend ongeacht het bijgevoegde resultaat van het onderzoek naar de stand van de techniek en schriftelijke opinie. Het octrooischrift komt overeen met de oorspronkelijk ingediende stukken.

METHOD FOR MANUFACTURING A CARRIER RING SUITABLE FOR USE
IN A DRIVE BELT FOR A CONTINUOUSLY VARIABLE TRANSMISSION

- This disclosure relates to a method for manufacturing a
5 ring from steel basic material that is suitable to
function as a carrier of transverse elements in a closed-
loop drive belt for a continuously variable transmission,
comprising the following steps:
- providing a plate of basic material;
 - 10 - bending the plate into a tube shape, whereby two side
faces are placed against each other,
 - fixing the said two side faces together in a welding
process to form a tube,
 - separating a ring-shaped section from the tube and
 - 15 - processing the ring-shaped tube section to form a
carrier ring for a drive belt, which processing at least
includes elongating the ring-shaped tube section in a
rolling process.
- 20 To avoid fracturing or damaging the tube and or the ring-
shaped tube section at the location of the weld and/or in
the so-called heat-affected zone of the welding process
when the ring-shaped section is separated from the tube,
the tube is annealed prior to such separating. In such
25 tube annealing process the brittleness that is introduced
in the welding process in the weld and heat affected zone
is removed by the recovery and the re-crystallization of
the material at a temperature considerably above 600
degrees Celsius, e.g. at about 800°C.
- 30 It is noted that the tube annealing process is required
for the same reason also in view of the rolling process,
i.e. for allowing the ring shaped tube section to be
elongated without being accompanied by unwanted
deformation or even fracturing from within the weld or the
35 heat affected zone thereof.

A drive belt for a continuously variable transmission is
generally known. Usually, such a drive belt comprises two

sets of endless, i.e. closed-loop rings that carry a multitude of transverse elements of the drive belt, which transverse elements are arranged in an essentially contiguous row along the entire circumference thereof.

5 These carrier rings of the drive belt are relatively flat, i.e. the radial distance between an inner circumference and an outer circumference of the carrier rings is relatively small with respect to the dimension in an axial direction.

10 In a continuously variable transmission, the drive belt is disposed between two cooperating pulleys where between a continuously variable speed ratio is realized. During operation, the drive belt transmits a torque from one of the pulleys to the other one pulley, a/o by the transverse

15 elements thereof pushing each other from the said one pulley to the said other one pulley.

During operation of the continuously variable transmission, the carrier rings of the drive belt are exposed to bending and pulling forces and, as a consequence, metal fatigue of

20 a carrier ring will play a role in a possible failure of the drive belt. The resistance of the carrier rings against such metal fatigue is largely determined by the type, quality and treatment of the used steel. A preferred

25 basic material that provides the required material properties for drive belt application of the carrier ring is maraging steel.

The separating of a ring-shaped section from the tube is

30 commonly performed by one or more rotating cutting blades that are forced into the material of the tube, which is rotated as well. Several basic arrangements of such separating process are known in the art, as, for example, described in the international patent applications

35 WO2005/039812-A1 and WO2004/089568-A1 and in the European patent applications EP-1130282-A and EP-1108919-A. However, in all such cases, the cutting blade or blades exert considerable (shear) stresses on the tube that can only be

accommodated without fracturing or unwanted deformation, if the material of the tube is sufficiently ductile. In practice this means that after the welding of the tube and prior to separating a ring-shaped section there from, the
5 tube must be annealed.

According to the present disclosure, by using a laser, plasma beam or similar heat source to separate a ring-shaped section from the tube by melting in a melt cutting
10 process, the said shear stresses do not occur. Consequently, with such melt cutting process the ductility or brittleness of the tube is hardly of influence on the quality of the cut, i.e. of the ring-shaped tube section. In any case the above-mentioned unwanted deformation or
15 fracturing thereof will not occur, not even without annealing the tube prior to the melt cutting thereof.

At first sight, this latter aspect of the melt cutting process appears irrelevant in practice, because the tube
20 annealing process must be carried out anyway, in order for the rolling process to be carried out without damaging or fracturing the ring-shaped tube section. However, based on an insight underlying the present disclosure, this aspect could still be favorably applied. In particular in
25 accordance with the present disclosure, the annealing after welding is postponed until after separating the ring-shaped tube section from the tube in a melt cutting process. Hereby the overall effectiveness, in particular cost effectiveness of the carrier ring manufacturing
30 method is improved.

The above-described basic features of the present disclosure will now be elucidated by way of example with
35 reference to the accompanying figures.

Figure 1 is a schematic illustration of a part of the known drive belt including two ring sets, each represented by a number of mutually nested carrier rings, as well as a

plurality of transverse elements.

Figure 2 is a diagram representing a known sequence of process steps in a known method for manufacturing a ring set for a drive belt from plate-shaped base material;

5 Figure 3 illustrates a known setup of the process step of separating a ring-shaped section from a tube in the known ring set manufacturing method.

Figure 4 illustrates an alternative setup of the process step of separating a ring-shaped section from a tube that is to be applied within the context of the present disclosure.

Figure 5 is a diagram representing a novel sequence of process steps as part of the manufacturing of the ring set in accordance with the present disclosure.

15

The known drive belt 3 that is schematically represented in part in figure 1 comprises two sets 31 of mutually nested, annular metal bands denoted carrier rings 32, as well as a several individual metal transverse elements 33, which transverse elements 33 are each provided with a recess 34 on either lateral side thereof wherein the ring sets 31 are provided. In the known drive belt 3 the transverse elements 33 form a row that spans and essentially continuously fills the entire circumference of the ring sets 31. During use in a transmission, the drive belt 3 is held between two transmission pulleys, whereby the ring sets 31 of the belt 3 are tensioned such that the row of transverse elements 33 can transmit a drive force from one pulley to another while being guided by the ring sets 31.

Figure 2 diagrammatically shows the major steps in a typical manufacturing method for forming the ring sets 31 of the drive belt 3, which includes the manufacturing of the intermediate product carrier ring.

35 In a first process step I, a plate 11 of basic material having a thickness of around 0.4 mm is bend into a cylindrical shape and the meeting side faces 12 of the

plate 11 are welded together in a second process step II to form a hollow cylinder or tube 13. In a third step III of the process the tube 13 is annealed, to recover and recrystallize the metal lattice, in an industrial oven 16 at
5 a temperature considerably above 600 degree Celsius, e.g. around 800 degree Celsius. Thereafter, in a fourth process step IV, a ring-shaped section 14 is separated from the main body of the tube 13. In the next step -process step five V- the lateral side faces or edges 15 of the ring-
10 shaped tube section 14 are treated to improve the surface quality and/or the shape thereof. In the illustrated example, the edge 15 treatment takes place by way of an edge melting process wherein the said edges 15 are reshaped by temporarily being melted by means of a heat
15 source such as a laser 20, which edge melting process is, as such, known from WO-2012/089228A1. Thereafter, the ring shaped tube section 14 is rolled in a sixth process step VI to reduce the thickness thereof to less than 0.2 mm, typically around 0.185 mm, while being elongated, thus
20 forming the carrier ring 32.

The carrier ring 32 is then subjected to a further annealing process step VII for removing the work hardening effect of the previous rolling process (i.e. step five VI).
25 Thereafter, in an eight process step VIII, the carrier ring 32 is calibrated, i.e. is mounted around two rotating rollers and stretched to a predefined circumference length by forcing the said rollers apart. In this eight process step VIII, also an internal stress distribution is imposed
30 on the carrier ring 32. Thereafter, the carrier ring 32 is heat-treated in two separate process steps, namely a ninth process step IX of ageing or bulk precipitation hardening and a tenth process step X of nitriding or case hardening. More in particular, both such heat-treatments involve
35 heating the carrier ring 32 in an oven chamber that is supplied with process gas that is typically composed of nitrogen and some, e.g. around 5 volume-% of hydrogen for ring ageing and of nitrogen and ammonia for ring nitriding.

Both heat-treatments typically occur within the temperature range from 400 degrees Celsius to 500 degrees Celsius and can each last for less than 30 to over 120 minutes in dependence on the metal used for the carrier ring 32 (i.e. typically a maraging steel alloy), as well as on the mechanical properties desired for the carrier ring 32.

Finally, a laminated ring set 31 is formed by radially stacking, i.e. nesting, a number of thus processed carrier rings 32, as is further indicated in figure 3 in the last depicted eleventh process step XI. Obviously, the carrier ring 32 of the ring set 31 have to be suitably dimensioned, e.g. have to differ slightly in circumference length to allow the carrier rings 32 to be closely fitted one around the other. To this end the carrier rings 32 of the ring set 31 are typically purposively selected from a stock of carrier rings 32 of varying dimensions.

A known setup of the above fourth process step IV of separating the ring-shaped tube section 14 from the tube 13 is schematically illustrated in figure 3. Figure 3 depicts the tube 13 in cross-section; however, in reality the diameter of the tube 13 is much larger relative its wall thickness. The circles 17 indicate several consecutive radial positions of an essentially cylindrical and rotatable cutting tool 17 relative to the tube 13 during the cutting process. However, in reality the cutting tool 17 has a fixed radial position, whereas the tube 13 is rotated with respect thereto. On the inside the tube 13 a counter tool 18 provides a support for the tube 13 when the cutting tool 17 moves radially inward during the cutting process. The actual cutting occurs in two phases I, II. In a first phase I of the cutting, the cutting tool 17 is gradually moved through the wall thickness (positions Ia-Ic) of the rotating tube 13 thus following a spiral cutting line C in the material of the tube 1. Then, in a second phase II of the cutting, the ring-shaped section is fully separated from the tube 13 in

one full rotation of the tube 13. It may be clear that in this known setup of the fourth process step IV a substantial cutting force is exerted on the tube 13 by the cutting tool 17.

5

An alternative setup of the process step IV of separating the ring-shaped tube section 14 from the tube 13 is schematically illustrated in figure 4. In this second embodiment a concentrated heat source (e.g. a laser beam) 10 19 is used to melt through the wall thickness of tube 13. In one full rotation of the tube 13 relative to the heat source 19, a complete circumferential cut is made from a start position S and the ring-shaped section 14 is separated from the tube 13. It may be clear that in this 15 particular setup of the fourth process step IV only minimal forces are exerted on the tube 13 and/or the ring-shaped section 14.

In practice, the internal stress, which is introduced into 20 the material of the tube 13 at welding, in combination with the forces exerted by a mechanical cutting tool 17, 18, such as the one illustrated in figure 3, cause the tube 13 and/or the ring-shaped tube section 14 to be damaged, e.g. by an unwanted deformation thereof, or even 25 to fracture. However, in a melt cutting process, no substantial cutting forces are exerted and, hence, the tube 13 and/or the ring-shaped tube section 14 will not be damaged thereby. Thus, the third process step III of tube annealing need not necessarily be carried out if the ring-shaped section 14 is separated from the tube 14 (process 30 step IV) by means of a melt cutting process instead of a mechanical cutting process. Still, the resulting ring-shaped tube section 14 must be annealed prior to the rolling thereof, i.e. prior to the sixth process step VI 35 of the manufacturing of the carrier ring 32 and finally of the ring set 31 of the drive belt 3.

According to the present disclosure the annealing of the

ring-shaped tube section 14 is favorably postponed, i.e. is carried out only until after the edges 15 thereof are treated in the fifth process step V. In this particular setup of the overall carrier ring manufacturing method, 5 the fifth process step V of edge melting can be carried out in accordance with the known art, i.e. including the after treatment of annealing as taught by WO-2012/089228A1, however, favorably without a second annealing process step prior to the sixth process step VI of rolling the ring- 10 shaped tube section 14. This novel setup of the relevant part of the manufacturing of the carrier ring is illustrated in figure 5.

According to figure 5, after the welding of the tube 13 in 15 the second process step II, the tube 13 is immediately cut into a several ring-shaped sections 14 in a melt cutting process, i.e. in the fourth process step IV, thus skipping the third step III of annealing in the conventional manufacturing method. Thereafter, in the fifth process 20 step V, the edges 15 of the ring-shaped tube section 14 are treated by a laser 20 that temporarily melts these edges 15. Only thereafter is the ring-shaped tube section 14 subjected to a process step V-b of annealing, in order to equalize the material properties throughout the ring- 25 shaped tube section 14 by recovery and re-crystallization. In this latter process step V-b the heat affected zones resulting from the welding process step II, the separating process step IV and the edge melting process step V are all removed simultaneously, i.e. favorably in a single 30 process step V-b. Thus in the said fourth process step IV of melt cutting and in the said fifth process step V of edge melting, the metal crystal structure of the tube 13 still includes the irregularities that were formed therein the second process step II of tube welding, i.e. still 35 includes a weld structure and a heat affected zone.

Finally, it is noted that, even if it is not opted for an edge melting process to treat the edges 15 of the ring-

shaped tube section 14 (process step V), but instead
another process such as stone tumbling or brushing is
applied for this purpose, it can still be advantageous to
anneal the ring-shaped tube section 14 only after such
5 another edge treatment process is completed. After all, in
this manner, only those intermediate products that meet
the required quality standards after melt cutting (process
step IV) and edge treatment (process step V) will (have
to) be annealed (process step V-b) prior to rolling
10 (process step VI).

The present disclosure, in addition to the entirety of the
preceding description and all details of the accompanying
figures, also concerns and includes all the features of
15 the appended set of claims. Bracketed references in the
claims do not limit the scope thereof, but are merely
provided as non-binding examples of the respective
features. The claimed features can be applied separately
in a given product or a given process, as the case may be,
20 but it is also possible that to apply any combination of
two or more of such features therein.

The invention(s) represented by the present disclosure is
(are) not limited to the embodiments and/or the examples
25 that are explicitly mentioned herein, but also encompasses
amendments, modifications and practical applications
thereof, in particular those that lie within reach of the
person skilled in the relevant art.

CONCLUSIES

1. Werkwijze voor de fabricage van een stalen dragerring (32), omvattende de volgende stappen:
 - 5 - het verschaffen van een plaat (11) van basismateriaal;
 - het in een buisvorm buigen van de plaat (11), waarbij twee zijvlakken (12) van de plaat (11) tegen, althans tegenover, elkaar worden geplaatst;
 - het vormen van een buis (13) door het aan elkaar lassen
 - 10 van de twee zijvlakken (12) van de gebogen plaat (11);
 - het afscheiden van een ringvormige buisdeel (14) van de van de buis (13); en
 - het nabehandelen van het ringvormige buisdeel (14) ten einde de dragerring (32) te vormen, tenminste omvattende
 - 15 het in een walsproces uitrekken van het ringvormige buisdeel (14), met het kenmerk, dat het van de buis (13) afscheiden van het ringvormige buisdeel (14) met behulp van een smelt-snijproces, zoals plasma- of lasersnijden, wordt uitge-
 - 20 voerd en dat het ringvormige buisdeel (14) vervolgens wordt onderworpen aan een (uit-)gloeiwarmtebehandeling, waarin het metaal van het ringvormige buisdeel (14) wordt gerekristalliseerd, voorafgaand aan het genoemde uitrekken daarvan in het walsproces.
 - 25
2. De werkwijze volgens de conclusie 1, waarin het ringvormige buisdeel (14) in de uitgloeiwarmtebehandeling in een ovenkamer (16) op een temperatuur van meer dan 600 graden Celsius wordt gebracht en gedurende enige tijd
- 30 wordt gehouden.
3. De werkwijze volgens de conclusie 1 of 2, waarin de buis (13) niet wordt onderworpen aan een uitgloeiwarmtebehandeling.
- 35
4. De werkwijze volgens de conclusie 1 of 2, waarin het metaal van de buis (13) van een onregelmatige kristal structuur is voorzien, meer in het bijzonder dat deze een

1040566

lasstructuur en/of een warmtebeïnvloede zone omvat.

5. De werkwijze volgens de conclusie 1, 2, 3 of 4, waarin de randen (15) van het ringvormige buisdeel (14),
5 voorafgaand aan de uitgloeï-warmtebehandeling daarvan, worden bewerkt door deze te smelten in een rand smeltproces.

6. De werkwijze volgens de conclusie 5, waarin het
10 ringvormige buisdeel (14) voorafgaand aan het rand smeltproces niet wordt onderworpen aan een uitgloeï-warmtebehandeling.

7. De werkwijze volgens één van de voorafgaande
15 conclusies, waarin de plaat (11), de buis (13) en/of het ringvormige buisdeel (14) een dikte bezit van om en nabij 0,4 mm.

8. De werkwijze volgens de conclusie 7, waarin de
20 dragerring (32) een dikte van minder dan 0,2 mm wordt voorzien.

9. De werkwijze volgens één van de voorafgaande
25 conclusies, met het kenmerk, dat de dragerring (32) bestemd is voor gebruik in of als een drijfriem (3) voor een continu variabele transmissie met twee poelies (1, 2) en de drijfriem (3).

10. Drijfriem (3) met dwarselementen (30) en tenminste één
30 ringenset (31) waarop de dwarselementen (10) zijn aangebracht en welke ringenset (31) is opgebouwd uit een aantal, in radiale zin onderling geneste, dragerringen (32) die zijn vervaardigd met behulp van ondermeer de werkwijze volgens één of meer der voorgaande conclusies,
35 in het bijzonder volgens de conclusie 8.

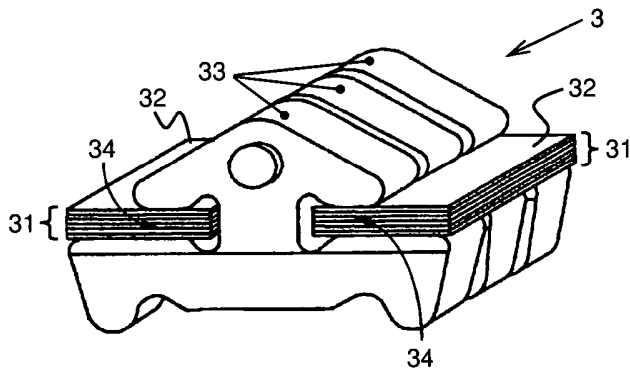

FIG. 1

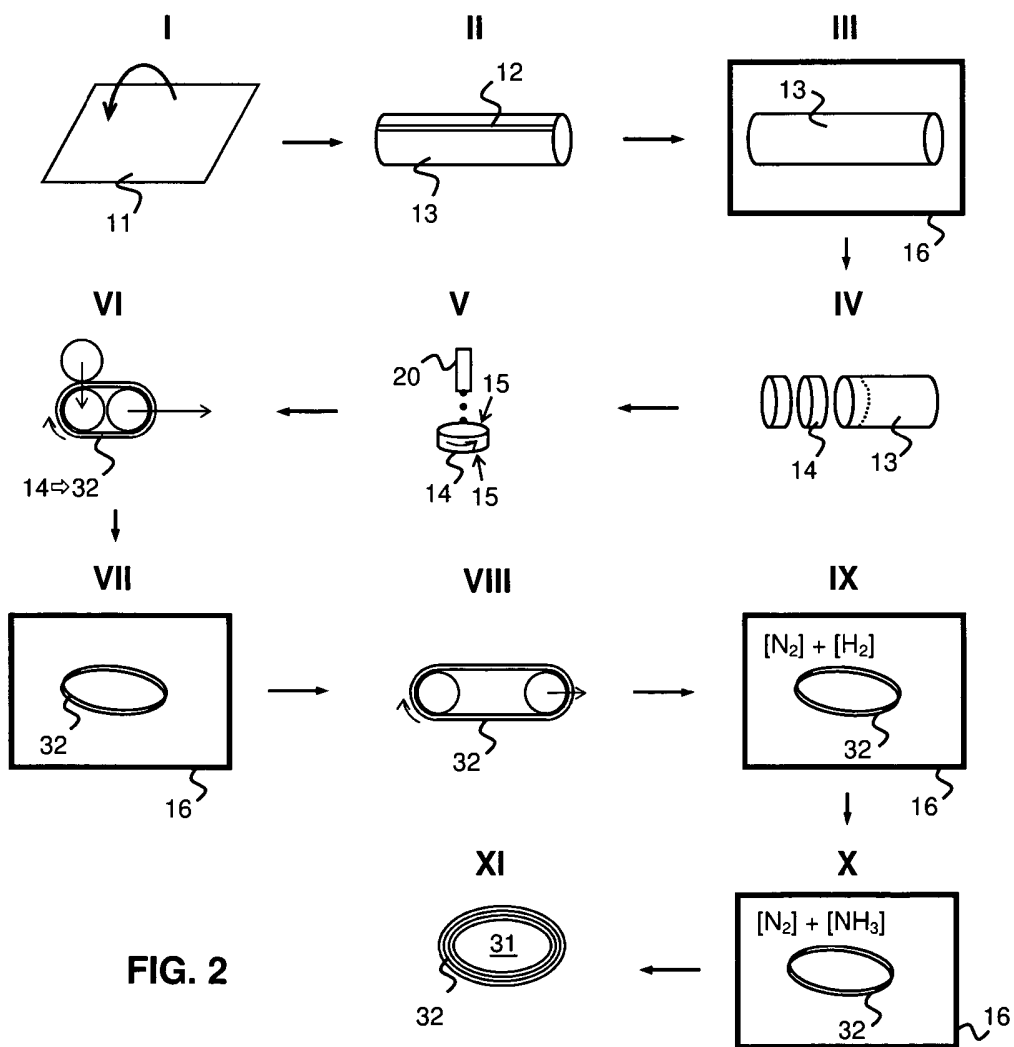

FIG. 2

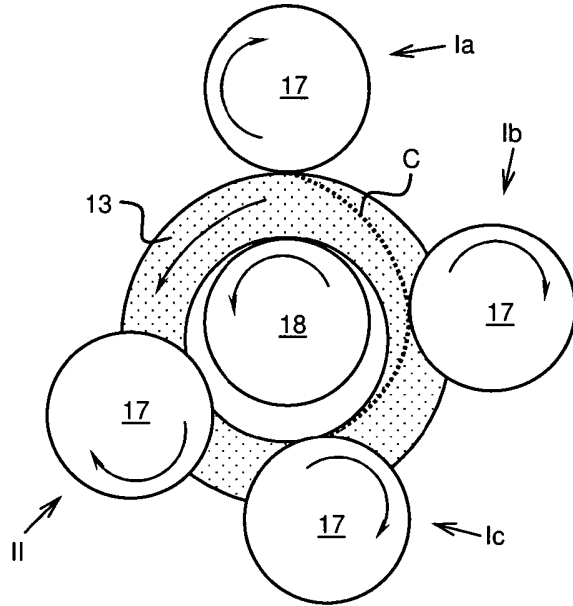

FIG. 3

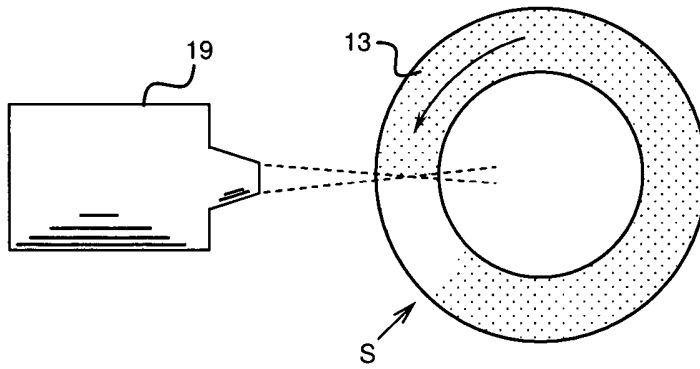

FIG. 4

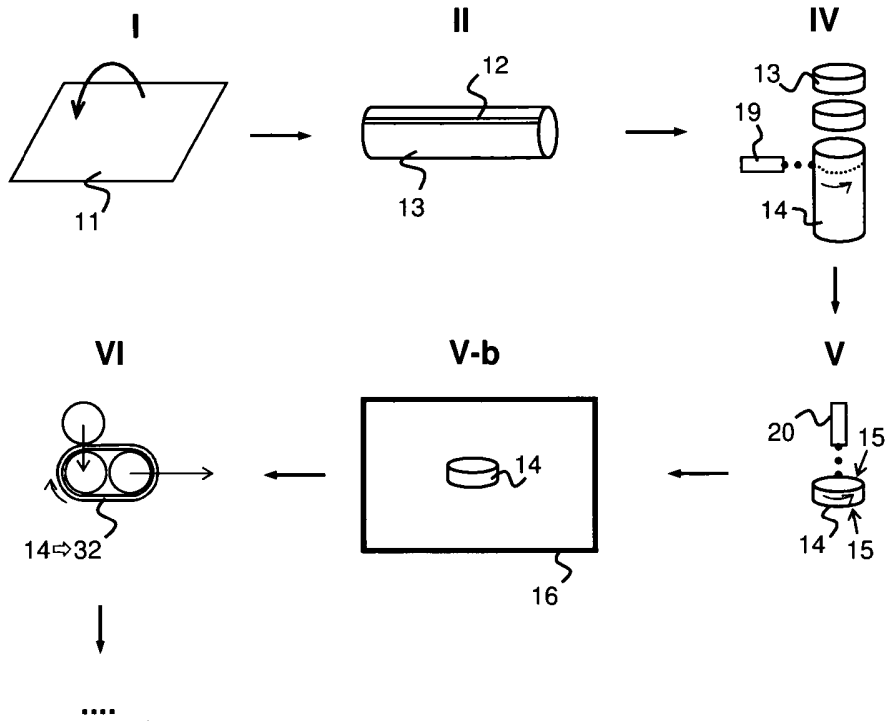

FIG. 5

SAMENWERKINGSVERDRAG (PCT)

RAPPORT BETREFFENDE NIEUWHEIDSONDERZOEK VAN INTERNATIONAAL TYPE

IDENTIFICATIE VAN DE NATIONALE AANVRAGE	KENMERK VAN DE AANVRAGER OF VAN DE GEMACHTIGDE	
	R.353439/PO	
Nederlands aanvraag nr.	Indieningsdatum	
1040566	24-12-2013	
	Ingeroepen voorrangsdatum	
Aanvrager (Naam)		
ROBERT BOSCH GMBH		
Datum van het verzoek voor een onderzoek van internationaal type	Door de Instantie voor Internationaal Onderzoek aan het verzoek voor een onderzoek van internationaal type toegekend nr.	
08-03-2014	SN 61626	
I. CLASSIFICATIE VAN HET ONDERWERP (bij toepassing van verschillende classificaties, alle classificatiesymbolen opgeven)		
Volgens de internationale classificatie (IPC)		
B23P15/00 F16G5/16		
II. ONDERZOCHE GEBIEDEN VAN DE TECHNIEK		
Onderzochte minimumdocumentatie		
Classificatiesysteem	Classificatiesymbolen	
IPC	B23P	F16G
Onderzochte andere documentatie dan de minimum documentatie, voor zover dergelijke documenten in de onderzochte gebieden zijn opgenomen		
III.	<input type="checkbox"/>	GEEN ONDERZOEK MOGELIJK VOOR BEPAALDE CONCLUSIES (opmerkingen op aanvullingsblad)
IV.	<input type="checkbox"/>	GEBREK AAN EENHEID VAN UITVINDING (opmerkingen op aanvullingsblad)

**ONDERZOEKSRAPPORT BETREFFENDE HET
RESULTAAT VAN HET ONDERZOEK NAAR DE STAND
VAN DE TECHNIEK VAN HET INTERNATIONALE TYPE**

Nummer van het verzoek om een onderzoek naar
de stand van de techniek

NL 1040566

A. CLASSIFICATIE VAN HET ONDERWERP
INV. B23P15/00 F16G5/16
ADD.

Volgens de Internationale Classificatie van octrooien (IPC) of zowel volgens de nationale classificatie als volgens de IPC.

B. ONDERZOCHE GEBIEDEN VAN DE TECHNIEK

Onderzochte minimum documentatie (classificatie gevolgd door classificatiesymbolen)
B23P F16G

Onderzochte andere documentatie dan de minimum documentatie, voor dergelijke documenten, voor zover dergelijke documenten in de onderzochte gebieden zijn opgenomen

Tijdens het onderzoek geraadpleegde elektronische gegevensbestanden (naam van de gegevensbestanden en, waar uitvoerbaar, gebruikte trefwoorden)

EPO-Internal, WPI Data

C. VAN BELANG GEACHTE DOCUMENTEN

Categorie °	Geciteerde documenten, eventueel met aanduiding van speciaal van belang zijnde passages	Van belang voor conclusie nr.
Y	WO 2013/000491 A1 (BOSCH GMBH ROBERT [DE]; PENNINGS BERT [NL]) 3 januari 2013 (2013-01-03) * bladzijde 7, regel 17 - bladzijde 8, regel 7; figuur 3 *	1-10
Y	----- US 2013/168372 A1 (NAKATSUKA KAZUSHIGE [JP] ET AL) 4 juli 2013 (2013-07-04) * alinea's [0016] - [0020]; figuren *	1-10
Y	----- WO 2012/089228 A1 (BOSCH GMBH ROBERT [DE]; VELTMANS PAUL [NL]; VERMEER JOHANNES ADRIANUS) 5 juli 2012 (2012-07-05) * bladzijde 5, regel 6 - bladzijde 6, regel 33; figuur 3 *	5,6
	----- -/--	

Verdere documenten worden vermeld in het vervolg van vak C.

Leden van dezelfde octroofamilie zijn vermeld in een bijlage

° Speciale categorieën van aangehaalde documenten

A niet tot de categorie X of Y behorende literatuur die de stand van de techniek beschrijft

D in de octrooiaanvraag vermeld

E eerdere octrooi(aanvraag), gepubliceerd op of na de indieningsdatum, waarin dezelfde uitvinding wordt beschreven

L om andere redenen vermelde literatuur

O niet-schriftelijke stand van de techniek

P tussen de voorrangdatum en de indieningsdatum gepubliceerde literatuur

T na de indieningsdatum of de voorrangdatum gepubliceerde literatuur die niet bezwarend is voor de octrooiaanvraag, maar wordt vermeld ter verheldering van de theorie of het principe dat ten grondslag ligt aan de uitvinding

X de conclusie wordt als niet nieuw of niet inventief beschouwd ten opzichte van deze literatuur

Y de conclusie wordt als niet inventief beschouwd ten opzichte van de combinatie van deze literatuur met andere geciteerde literatuur van dezelfde categorie, waarbij de combinatie voor de vakman voor de hand liggend wordt geacht

& lid van dezelfde octroofamilie of overeenkomstige octrooipublicatie

Datum waarop het onderzoek naar de stand van de techniek van internationaal type werd voltooid

30 juni 2014

Verzenddatum van het rapport van het onderzoek naar de stand van de techniek van internationaal type

Naam en adres van de instantie

European Patent Office, P.B. 5818 Patentlaan 2
NL - 2280 HV Rijswijk
Tel. (+31-70) 340-2040,
Fax: (+31-70) 340-3016

De bevoegde ambtenaar

Popma, Ronald

**ONDERZOEKSRAPPORT BETREFFENDE HET
RESULTAAT VAN HET ONDERZOEK NAAR DE STAND
VAN DE TECHNIEK VAN HET INTERNATIONALE TYPE**

Nummer van het verzoek om een onderzoek naar
de stand van de techniek

NL 1040566

C.(Vervolg). VAN BELANG GEACHTE DOCUMENTEN		
Categorie °	Geciteerde documenten, eventueel met aanduiding van speciaal van belang zijnde passages	Van belang voor conclusie nr.
A	<p>WO 2013/002633 A1 (BOSCH GMBH ROBERT [DE]; JANSSEN WILHELMUS PETRUS MARIA [NL]; BRANSMA A) 3 januari 2013 (2013-01-03) * bladzijde 5, regel 21 - bladzijde 6, regel 5; figuur 3 *</p> <p style="text-align: center;">-----</p>	1-10
A	<p>WO 2011/076397 A1 (BOSCH GMBH ROBERT [DE]; PENNINGS BERT [NL]) 30 juni 2011 (2011-06-30) * bladzijde 4, regel 9 - bladzijde 5, regel 7; figuur 3 *</p> <p style="text-align: center;">-----</p>	1-10

**ONDERZOEKSRAPPORT BETREFFENDE HET
RESULTAAT VAN HET ONDERZOEK NAAR DE STAND
VAN DE TECHNIEK VAN HET INTERNATIONALE TYPE**

Informatie over leden van dezelfde octrooifamilie

Nummer van het verzoek om een onderzoek naar
de stand van de techniek

NL 1040566

In het rapport genoemd octrooigeschrift	Datum van publicatie	Overeenkomend(e) geschrift(en)	Datum van publicatie	
WO 2013000491	A1	03-01-2013	CN 103703274 A EP 2739877 A1 WO 2013000491 A1	02-04-2014 11-06-2014 03-01-2013
US 2013168372	A1	04-07-2013	US 2013168372 A1 WO 2012111213 A1	04-07-2013 23-08-2012
WO 2012089228	A1	05-07-2012	JP 2014506312 A WO 2012089228 A1	13-03-2014 05-07-2012
WO 2013002633	A1	03-01-2013	CN 103732782 A WO 2013002633 A1	16-04-2014 03-01-2013
WO 2011076397	A1	30-06-2011	NL 1037583 C WO 2011076397 A1	27-06-2011 30-06-2011

WRITTEN OPINION

File No. SN61626	Filing date (day/month/year) 24.12.2013	Priority date (day/month/year)	Application No. NL1040566
International Patent Classification (IPC) INV. B23P15/00 F16G5/16			
Applicant ROBERT BOSCH GMBH			

This opinion contains indications relating to the following items:

- Box No. I Basis of the opinion
- Box No. II Priority
- Box No. III Non-establishment of opinion with regard to novelty, inventive step and industrial applicability
- Box No. IV Lack of unity of invention
- Box No. V Reasoned statement with regard to novelty, inventive step or industrial applicability; citations and explanations supporting such statement
- Box No. VI Certain documents cited
- Box No. VII Certain defects in the application
- Box No. VIII Certain observations on the application

	Examiner Popma, Ronald
--	---------------------------

WRITTEN OPINION

Application number
NL1040566

Box No. I Basis of this opinion

1. This opinion has been established on the basis of the latest set of claims filed before the start of the search.
2. With regard to any **nucleotide and/or amino acid sequence** disclosed in the application and necessary to the claimed invention, this opinion has been established on the basis of:
 - a. type of material:
 - a sequence listing
 - table(s) related to the sequence listing
 - b. format of material:
 - on paper
 - in electronic form
 - c. time of filing/furnishing:
 - contained in the application as filed.
 - filed together with the application in electronic form.
 - furnished subsequently for the purposes of search.
3. In addition, in the case that more than one version or copy of a sequence listing and/or table relating thereto has been filed or furnished, the required statements that the information in the subsequent or additional copies is identical to that in the application as filed or does not go beyond the application as filed, as appropriate, were furnished.
4. Additional comments:

Box No. V Reasoned statement with regard to novelty, inventive step or industrial applicability; citations and explanations supporting such statement

1. Statement

Novelty	Yes: Claims	1-10
	No: Claims	
Inventive step	Yes: Claims	
	No: Claims	1-10
Industrial applicability	Yes: Claims	1-10
	No: Claims	

2. Citations and explanations

see separate sheet

Re Item V

Reasoned statement with regard to novelty, inventive step or industrial applicability; citations and explanations supporting such statement

- 1 Reference is made to the following documents:
 - D1 WO 2013/000491 A1 (BOSCH GMBH ROBERT [DE]; PENNINGSBERT [NL]) 3 januari 2013 (2013-01-03)
 - D2 US 2013/168372 A1 (NAKATSUKA KAZUSHIGE [JP] ET AL) 4 juli 2013 (2013-07-04)
 - D3 WO 2012/089228 A1 (BOSCH GMBH ROBERT [DE]; VELTMANS PAUL [NL]; VERMEER JOHANNES ADRIANUS) 5 juli 2012 (2012-07-05)
- 2 The present application does not meet the criteria of patentability, because the subject-matter of claim 1 does not involve an inventive step.
 - 2.1 D1 may be regarded as being the prior art closest to the subject-matter of claim 1, and discloses in (bladzijde 7, regel 17 - bladzijde 8, regel 7; figuur 3)
 - 2.2 Werkwijze voor de fabricage van een stalen dragerring (32), omvattende de volgende stappen:
 - het verschaffen van een plaat (11) van basismateriaal;
 - het in een buisvorm buigen van de plaat (11), waarbij twee zijvlakken (12) van de plaat (11) tegen, althans tegenover, elkaar worden geplaatst;
 - het vormen van een buis (13) door het aan elkaar lassen van de twee zijvlakken (12) van de gebogen plaat (11);
 - het afscheiden van een ringvormige buisdeel (14) van de van de buis (13);
 - en
 - het nabehandelen van het ringvormige buisdeel (14) ten einde de dragerring (32) te vormen, tenminste omvattende het in een walsproces uitrekken van het ringvormige buisdeel (14)
 - 2.3 The subject-matter of claim 1 therefore differs from this known werkwijze in that:
 - 2.4 het van de buis (13) afscheiden van het ringvormige buisdeel (14) met behulp van een smelt- snijproces, zoals plasma- of lasersnijden, wordt uitge voerd en dat het ringvormige buisdeel (14) vervolgens wordt onderworpen aan een (uit-)gloeï-warmtebehandeling, waarin het metaal van het ringvormige buisdeel (14) wordt gerekristalliseerd, voorafgaand aan het genoemde uitrekken daarvan in het walsproces.

- 2.5 The problem to be solved by the present invention may therefore be regarded as an alternative way to cut the rings from a cylinder.
- 2.6 The solution proposed in claim 1 of the present application cannot be considered as involving an inventive step for the following reasons: D2 in (alineaas [0016] - [0020]; figuren) shows all the features of the characterising part of claim 1. Thus the man skilled in the art would not need an inventive step to combine the features of D1 and D2 to come to the combined features of claim 1 of the application.
- 3 Dependent claims 2-10 do not contain any features which, in combination with the features of any claim to which they refer, meet the requirements of novelty and/or inventive step, see D1 (bladzijde 7, regel 17 - bladzijde 8, regel 7; figuur 3) for all the features of claims 2-4 and 7-10. And D3 (bladzijde 5, regel 6 - bladzijde 6, regel 33; figuur 3) for the edge melting process in claims 5 and 6.