

(19) World Intellectual Property Organization  
International Bureau



(43) International Publication Date  
26 May 2006 (26.05.2006)

PCT

(10) International Publication Number  
WO 2006/055736 A1

- (51) International Patent Classification:  
G06K 7/10 (2006.01)
- (21) International Application Number:  
PCT/US2005/041731
- (22) International Filing Date:  
16 November 2005 (16.11.2005)
- (25) Filing Language: English
- (26) Publication Language: English
- (30) Priority Data:  
60/628,897 16 November 2004 (16.11.2004) US
- (71) Applicant (for all designated States except US): **ILLUMINA, INC.** [US/CA]; 9885 Towne Centre Drive, San Diego, CA 92121-1975 (US).

AT, AU, AZ, BA, BB, BG, BR, BW, BY, BZ, CA, CH, CN, CO, CR, CU, CZ, DE, DK, DM, DZ, EC, EE, EG, ES, FI, GB, GD, GE, GH, GM, HR, HU, ID, IL, IN, IS, JP, KE, KG, KM, KN, KP, KR, KZ, LC, LK, LR, LS, LT, LU, LV, LY, MA, MD, MG, MK, MN, MW, MX, MZ, NA, NG, NI, NO, NZ, OM, PG, PH, PL, PT, RO, RU, SC, SD, SE, SG, SK, SL, SM, SY, TJ, TM, TN, TR, TT, TZ, UA, UG, US, UZ, VC, VN, YU, ZA, ZM, ZW.

(84) Designated States (unless otherwise indicated, for every kind of regional protection available): ARIPO (BW, GH, GM, KE, LS, MW, MZ, NA, SD, SL, SZ, TZ, UG, ZM, ZW), Eurasian (AM, AZ, BY, KG, KZ, MD, RU, TJ, TM), European (AT, BE, BG, CH, CY, CZ, DE, DK, EE, ES, FI, FR, GB, GR, HU, IE, IS, IT, LT, LU, LV, MC, NL, PL, PT, RO, SE, SI, SK, TR), OAPI (BF, BJ, CF, CG, CI, CM, GA, GN, GQ, GW, ML, MR, NE, SN, TD, TG).

**Published:**  
— with international search report  
— before the expiration of the time limit for amending the claims and to be republished in the event of receipt of amendments

For two-letter codes and other abbreviations, refer to the "Guidance Notes on Codes and Abbreviations" appearing at the beginning of each regular issue of the PCT Gazette.

- (72) Inventor: **MOON, John, A.**
- (74) Agent: **BARBER, William, J.**; Ware, Fressola, Van Der Sluys & Adolphson LLP, Bradford Green, Building 5, 755 Main Street, P.O. Box 224, Monroe, CT 06468 (US).
- (81) Designated States (unless otherwise indicated, for every kind of national protection available): AE, AG, AL, AM,

(54) Title: AND METHODS AND APPARATUS FOR READING CODED MICROBEADS

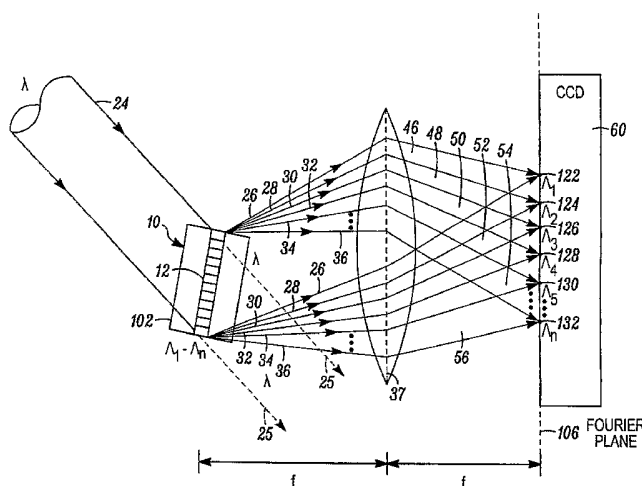

(57) Abstract: A method and apparatus for reading a microbead having a code thereon is provided wherein the code is projected on and read from a Fourier plane. The microbead may be 1-1000 microns (um) or smaller in feature size. The code is projected on the Fourier plane by scattering input light off the microbead. The scattered light from the microbead is directed through an optical arrangement having a transform lens for projecting the code on the Fourier plane, and read on the Fourier plane using a charge coupled device (CCD) or other similar device. The code may include periodic layers of material having different refractivities or phase, including index of refraction differences; periodic spatial modulations having a different phase or amplitude; a periodic binary phase change used to code information in the Fourier plane; a photonic crystal used to encode the information on the microbead, wherein a pattern of holes causes interference between incident and scattered light to form spatial and spectral patterns in the far field that are unique to the pattern of holes; or may be formed in the microbead using a single photoactive inner region, a series of longitudinal holes, different fluorescence regions, or concentric rings of material in a preform.

WO 2006/055736 A1

## METHOD AND APPARATUS FOR READING CODED MICROBEADS

## CROSS REFERENCES TO RELATED APPLICATIONS

This application claims benefit to U.S. provisional patent application no. 60/628,897 (WFVA/CyVERA nos. 714-1.9/CV 0056PR), filed November 16, 2004, which is hereby incorporated by reference in their entirety.

The following cases contain subject matter also related to that disclosed herein and are incorporated herein by reference in their entirety, as follows: U.S. Provisional Patent Application Serial No. 60/441,678, filed January 22, 2003, entitled "Hybrid Random Bead/Chip Microarray" (Attorney Docket No. CC-0574); U.S. Patent Application Serial No. 10/645,689, filed August 20, 2003, entitled "Diffraction Grating-Based Optical Identification Element" (Attorney Docket No. CC-0648); U.S. Patent Application Serial No. 10/645,686 filed August 20, 2003, entitled "End Illuminated Bragg Grating based Optical Identification Element" (Attorney Docket No. CC-0649); U.S. Patent Application Serial No. 10/661,031, filed September 12, 2003, entitled "End Illuminated Bragg Grating based Optical Identification Element", (Attorney Docket No. CC-0649A); U.S. Patent Application Serial No. 10/661,082, filed September 12, 2003, entitled "Method and Apparatus for Labeling Using Diffraction Grating-based Encoded Optical Identification

Elements" (Attorney Docket No. CC-0650); U.S. Patent Application Serial No. 10/661,115, filed September 12, 2003, entitled "Assay Stick" (Attorney Docket No. CC-0651); U.S. Patent Application Serial No. 10/661,836, filed September 12, 2003, entitled "Method and Apparatus for Aligning Microbeads in order to Interrogate the Same" (Attorney Docket No. CC-0652); U.S. Patent Application Serial No. 10/661,254 filed September 12, 2003, entitled "Chemical Synthesis Using Diffraction Grating-based Encoded Optical Elements" (Attorney Docket No. CC-0653); U.S. Patent Application Serial No. 10/661,116 filed September 12, 2003, entitled "Method of Manufacturing of a Diffraction grating-based identification Element" (Attorney Docket No. CC-0654); U.S. Provisional Patent Application Serial No. 60/519,932, filed November 14, 2003, entitled, "Diffraction Grating-Based Encoded Microparticles for Multiplexed Experiments" (Attorney Docket No. CC-0678); and U.S. Patent Application Serial No. 10/763,995 filed January 22, 2004, entitled, "Hybrid Random bead/chip based microarray" (Attorney Docket No. CV-0054).

## BACKGROUND OF THE INVENTION

## 1. Field Of Invention

The present invention relates to a method and apparatus for reading a code on an optical element; and more particularly, to a method and apparatus for reading a code on a microbead that is typically 1-1000 microns in size using a Fourier plane analysis technique.

## 2. Description of Related Art

Tiny microbeads that are individually identifiable have many applications in drug discovery, genomics, chemistry, and security. Microbeads are very small objects, typically 1-1000 microns (um) in feature size. They may be cylindrical, cubic, rectangular, or any other shape. Typically microbeads are composed of silica based glass. Coded microbeads are individually identifiable. There are many methods available to encode microbeads. Known methods for encoding microbeads include fluorescence intensity and/or color, chemical techniques, spatial marks on the particles and radio-frequency encoding. However, the known ways involve using expensive, high resolution, optical techniques for imaging and reading the code off the microbead.

For example, Figure 1 shows such a spatial imaging technique generally indicated as 10' for reading encoded particles or microbeads that is known in the art, and

includes an input light source 12' for passing input light through a microbead 14 and imaging optics, including an imaging lens 16, to project an image of the microbead 14 on an imaging plane 18 for reading the image using expensive, high resolution, imaging equipment 20. The imaging lens 16 is arranged between the microbead 14 and the image plane 18 at a distance of two focal lengths from each. The imaging optics are also expensive to provide the high resolution image needed to read or interpret the code on the microbead.

In view of this, there is a need in the industry for a less expensive way to encode and decode microbeads.

#### SUMMARY OF INVENTION

In its broadest sense, the present invention provides a new and unique method and apparatus for reading a microbead having a code thereon, wherein the code is projected on and read from a Fourier plane.

In operation, the code is projected on the Fourier plane by first scattering input light off (reflected or transmitted) the microbead. The light scattered from the microbead is directed through an optical arrangement having a transform lens for projecting the code on the Fourier plane, and read on the Fourier plane with a Fourier plane reading device, including a charge coupled device (CCD) or other suitable Fourier plane reading

device and a processor for performing Fourier plane analysis. The transform lens is arranged between the microbead and the Fourier plane at a distance of one focal length from each, while the charge coupled device (CCD) or other suitable Fourier plane reading device is arranged on the Fourier plane. The whole thrust of the present invention is to analyze the spatial frequency of the light that is projected on the Fourier plane, after scattering from through the microbead and optical arrangement.

The microbead may be 1-1000 microns ( $\mu\text{m}$ ) or smaller in feature size.

The code may include periodic layers of material having different absorption, refractivities, or phase, including index of refraction differences; periodic spatial modulations having a different phase or amplitude; a periodic binary phase change used to code information in the Fourier plane; a photonic crystal used to encode the information on the microbead, wherein a pattern of holes causes interference between incident and scattered light to form spatial and spectral patterns in the far field that are unique to the pattern of holes; or may be formed in the microbead using a single photoactive inner region, a series of longitudinal holes, different fluorescence regions, or concentric rings of material in a preform. In effect, the present invention has

applications in reading any unique and repeatable code formed in a microbead that can be projected on and read from a Fourier plane, including codes that are presently otherwise imaged on an image plane in the prior art in order to be read.

The present invention also provides new and unique Fourier scattering techniques for encoding microbeads, as well as providing one or more new and unique microbeads having a code thereon that may be projected on and read from a Fourier plane according to the method disclosed herein.

One important advantage of the present invention is that the Fourier plane analysis enables the use of a substantially less expensive code reader and code reading optics, such as a CCD array, since the code on the microbead does not have to be imaged in high order resolution in order to be interpreted.

Another advantage is that translationally invariant codes may be written over a large area when an optical filament is drawn from a preform and then cut into smaller sections in order to make the microbeads.

Still another advantage is that, because the code is projected and read in the Fourier plane or "far field", the reader does not require expensive or powerful imaging and magnifying optics to create a high resolution magnified image of the bead/particle to read the code.

This is different from the prior art which actually image the bead itself to determine the code, e.g., for small particles that have bar codes printed on them.

#### BRIEF DESCRIPTION OF THE DRAWING

The drawing, not drawn to scale, includes the following Figures:

Figure 1 shows a diagram of a spatial imaging technique for reading encoded particles or microbeads that is known in the art.

Figure 2 shows a diagram of a new technique for reading encoded particles or microbeads according to the present invention.

Figure 2a shows another diagram of the new technique for reading encoded particles or microbeads according to the present invention.

Figure 3 shows a diagram of a microbead or optical element 102 as shown in Figure 2.

Figure 4 shows an example of a Fourier plane readout of a multilayer metallic particle, which obviates the need for a high resolution imaging system.

Figure 5 shows examples of Fourier scattering techniques based on different inner region geometries in a filament drawn and cut from a preform to form microbeads according to the present invention.

Figure 6 shows another example of Fourier scattering



techniques using photonic crystal microparticles which encode information according to the present invention.

#### DETAILED DESCRIPTION OF INVENTION

Figure 2 shows an optical arrangement using a Fourier transform technique generally indicated as 100 for reading a microbead or other suitable optical element generally indicated 102 having a code 104 (See, for example, Figure 3) written thereon, wherein the code 104 is projected on and read from a Fourier plane 106.

In operation, the code 104 is projected on the Fourier plane 106 by passing input light from an input light source 108 through the microbead 102 and an optical arrangement having a transform lens 110 for focusing the code 104 on the Fourier plane 106, and read on the Fourier plane 106 with a Fourier plane reading device 112, including a charge coupled device (CCD) or other suitable Fourier plane reading device and a processor for performing Fourier plane analysis. The transform lens 110 is arranged between the microbead 102 and the Fourier plane 106 at a distance of about one focal length  $f$  from each, while the charge coupled device (CCD) or other suitable Fourier plane reading device is arranged on the Fourier plane. The light at the CCD device 112 is placed at the Fourier plane, and represents the Fourier transform of the resultant refractive index variation in

the microbead 102. The whole thrust of the present invention is to analyze the spatial frequency of the light that is projected on the Fourier plane 106, after passing through or scattering off the microbead and optical arrangement.

The Fourier transform optics, including the transform lens 110, for focusing the code 104 (Figure 3) on the Fourier plane 106 is known in the art, and the scope of the invention is not intended to be limited to any particular type or kind thereof. Moreover, the scope of the invention is intended to include using other optical arrangement, with or without such transform lens, now known or later developed in the future.

The charge coupled device (CCD) or other suitable Fourier plane reading device is an inexpensive optical device that are known in the art, and the scope of the invention is not intended to be limited to any particular type or kind thereof.

The optical arrangement 100 also includes a Fourier plane transform processor 114 for performing Fourier plane analysis to determine the code from the resultant refractive index variation. The Fourier plane transform processor 114 may be implemented using hardware, software, firmware, or some combination thereof. In a typical software implementation, the Fourier plane transform processor 114 may be one or more

microprocessor-based architectures having a microprocessor, a random access memory (RAM), a read only memory (ROM), input/output devices and control, data and address buses connecting the same. A person skilled in the art of programming would be able to program such a microprocessor-based implementation to perform the functionality described herein without undue experimentation. The scope of the invention is not intended to be limited to any particular implementation using technology known or later developed in the future. Moreover, the processor 114 may form part of the Fourier plane reading device 112, or may be implemented as a separate module or processing unit. Finally, the scope of the present invention is also intended to include implementing one or more steps to carry out the invention via a computer program running in a Fourier plane transform processor, controller or other suitable module in an optical system, including but not limited to performing the Fourier plane analysis to determine the code from the resultant refractive index variation.

#### Figure 2a

Fig. 2a shows another example of the Fourier transform technique similar to the optical arrangement in Figure 2, wherein an incident light 24 of a wavelength  $\lambda$ , e.g., 532 nm from a known frequency doubled Nd:YAG laser

or 632nm from a known Helium-Neon laser, is incident on a grating 12 in a substrate 10 of a microbead such as 102 in Figure 2. Any other input wavelength  $\lambda$  can be used if desired provided  $\lambda$  is within the optical transmission range of the substrate (discussed more hereinafter). A portion of the input light 24 passes straight through the grating 12 as indicated by dashed lines 25. The remainder of the light 24 is reflected by the grating 12 and forms a plurality of beams 26-36, each having the same wavelength  $\lambda$  as the input wavelength  $\lambda$  and each having a different angle indicative of the pitches ( $\Lambda_1$ - $\Lambda_n$ ) existing in the grating 12. The reflected light 26-36 passes through a transform lens 37, which is arranged between the microbead 102 and the Fourier plane 106 at a distance of about one focal length  $f$  from each. The transform lens 37 provides focused light beams 46-56 which are imaged on the Fourier plane 106 at locations 122, 124, 126, 128, 130, 132 onto a CCD camera 60. Consistent with that discussed above, instead of or in addition to the lens 37, other imaging optics may be used to provide the desired characteristics of the optical image/signal onto the camera 60 (e.g., spots, lines, circles, ovals, etc.), depending on the shape of the substrate and input optical signals. Also, instead of a CCD camera other devices may be used to read/capture the

output light.

Figure 3: The Microbead or Optical Element 102

Figure 3 shows, by way of example, the microbead 102 including the code 104 in the form of periodic layers of material with different reflectivity, which is known in the art. The material having different reflective spaces 104a, 104b, 104c, ..., 104o may include one reflectivity that may represent a logical "0" (indicated by blank spaces generally indicated by lead lines 104b, 104e, 104f, etc.), while the material having the other reflectivity may represent a logical "1" (indicated by elements 104a, 104c, 104d, etc.), or vice versa. As shown, the code 104 represents the binomial number "101 110 010 011 001", or "010 001 101 100 110" if the logical representation of the reflectivity is reversed.

Consistent with that discussed above, the scope of the invention is not intended to be limited to any particular code or coding method or technique. Moreover, the scope of the invention is intended to be used in conjunction with known coding techniques, coding techniques that form part of the invention as described herein, as well as coding techniques later developed in the future.

Alternatively, the code 104 may include periodic layers of material having a different phase, including index of refraction differences; periodic spatial

modulations having a different phase or amplitude; a periodic binary phase change used to code information in the Fourier plane; a photonic crystal used to encode the information on the microbead, wherein a pattern of holes causes interference between incident and scattered light to form spatial and spectral patterns in the far field that are unique to the pattern of holes; or may be formed in the microbead using a single photoactive inner region, a series of longitudinal holes, different fluorescence regions, or concentric rings of material in a preform. In effect, the present invention has applications in reading any code that is unique and repeatable, including codes that are otherwise imaged on an image plane in the prior art in order to be read.

The microbead or optical element 102 may be microscopic in size having a length in a range of 1-1,000 microns or smaller; or for larger applications may have a length of 1.0 - 1,000 millimeters or more. The outer diameter may be as small as less than 1,000 microns, as well as in a range of 1.0 to 1,000 millimeters for larger applications. Using manufacturing techniques developed in conjunction with the development of the present invention, one optical fiber or substrate can be drawn and processed to produce hundreds of thousands, as well as even a million or more of such unique microbeads. The microbead or optical element 102 may be used in which a

substrate is used such as an optical substrate having the refractive index of the inner region is less than or equal to the outer region. By way of example, the reader is referred to the optical elements disclosed in provisional patent application serial nos. 60/546,445 (CV-35), 60/546,435 (CV-53), 60/547,013 (CV-65), all filed on February 19, 2004, as well as application serial no. 661,836 (CC-652), filed on September 12, 2003, which are all hereby incorporated by reference. The scope of the invention is not intended to be limited to the type, kind, shape or size of the microbead or optical element 102. The scope of the invention is intended to include optical substrates both now known and later developed in the future.

Figure 4:

Figure 4 shows an example of a Fourier plane readout of a multilayer metallic particle, which obviates the need for a high resolution imaging system. Similar elements in Figures 2 and 4 are labelled with similar reference numeral. In this example, the microbead 102 has the code 104 in the form of a periodic spatial modulation (amplitude or phase) that reflects an incident light 108 through a transform lens 110 onto the Fourier plane, where the periodicity causes a "dot" or bit which may be read and interpreted accordingly.

It is important to note that, although in principle analog patterns can be used to encode in the Fourier plane, it is often advantageous to use only two "levels", where the levels can be either the phase (index) change and/or absorption change. For instance, the metallic layered particles of one known coding technique could be read out in a Fourier plane, thus obviating the necessity of a high resolution microscope. Periodic modulations of phase or amplitude can be "written" into an optical filament after it is drawn from a preform, allowing flexibility in the amount of particles that are encoded in a single batch.

#### Figures 5 and 6: Other Fourier Scattering Techniques for Encoding Microbeads

The present invention also provides many different types of Fourier scattering techniques for encoding microbeads that can be read using the Fourier plane analysis technique described herein. For example, many different geometries of the inner region and/or can be envisioned that can lead to a uniquely identifiable marking of the diced microbeads, including: a single photoactive inner region (Figure 5A), a series of longitudinal holes (Figure 5B), different fluorescence regions (Figure 5C), or concentric rings (Figure 5D) of material in the preform to name a few examples. These



markings or patterns may be formed in the inner region and/or outer region of an optical filament drawn from a preform and cut to form the microbeads. These patterns on the microbeads are unique and repeatable and may be read using the Fourier plane analysis technique shown and described herein.

Figure 6 shows still another examples of Fourier scattering techniques using photonic crystal microparticles which encode information according to the present invention. The pattern of the holes causes interferences between the incident and scattered light to form spatial and spectral patterns in the far field that are unique to the pattern of holes. In operation, incident light is provided to a microbead 102' having a photonic crystal therein causing a radiation pattern and spectrum that uniquely encodes information that can be read using the Fourier plane analysis technique described herein.

The scope of the invention is not intended to be limited to any particular pattern formed in the inner region and/or outer region of the filament being drawn from a preform using techniques now known or later developed in the future.

#### Figure 7: The Imaging Properties

Referring to Fig. 7, the imaging properties of a

known positive lens 402 may be described according to the following known principles. If an object 404 is located a distance  $s_o$  away from the lens 402, i.e., in an "object plane", the lens 402 will form an image 406 in an "image plane" of the object 404 a distance  $s_i$  away from the lens 402. The known relationship between  $s_o$  and  $s_i$  can be written as follows:

$$\frac{1}{s_o} + \frac{1}{s_i} = \frac{1}{f}$$

where  $f$  is the focal length of the lens 402 and  $s_o$  is greater than the focal length of the lens 402. The size of the image relative to the object (or magnification  $M$ ) has the known relationship:

$$M = \frac{s_i}{s_o}$$

where  $M$  is the size of the image 406 divided by the size of the object 404. Accordingly, if the lens 402 is placed a distance  $f$  away from the object 404, the image 405 is infinitely large at a distance of infinity away from the lens 402, as is known. For the purposes of this discussion, the lens 402 is presumed to be infinitely large, infinitely thin (i.e., a line) as located on a plane parallel to the plane of the lens, and with no aberrations.

## Figure 8: The Fourier Properties

Referring to Figure 8, the Fourier properties of a lens 402 may be described based on the following known principles. If the lens 402 is placed a distance  $f$  in front of an electric field distribution 408, the lens 402 will form an electric field distribution 410 that corresponds to the Fourier transform of the original electric field profile 408 at a distance  $f$  away from the lens 402 (i.e., at the "Fourier Plane" 411). The Fourier Plane image is also known as the "far field" image with a different scale, e.g., greater than about 20 Rayleigh ranges away. In particular, for the electric field sine wave 408 having a predetermined intensity or peak value and a DC offset, resulting Fourier transform intensity pattern in the Fourier Plane 411 provided by the lens 402 would be three delta functions (or points of light) 410, 412, 414, corresponding to the DC value at the point 412, the positive frequency value of the sine wave 408 at the point 410 and the negative value of the frequency of the sine wave 408 at the point 414. The intensity of the light at the point 412 corresponds to the DC value of the sine wave 408, and the intensity of the light at the points 410, 414 corresponds to the peak value of the sine wave 408.

Relating the Fourier Plane discussion above to a bar

code printed on a bead or particle such as element 102 (Figure 2) that is read by an optical reader such as element 112 (Figure 2), the sine wave 408 could correspond to the bar code on the bead 102 having a single spatial period, an efficiency  $< 100\%$ , and where a light beam 412 is incident on the bead at an angle of 0 degrees to the normal of the grating vector (the longitudinal axis of the bead 8).

It should be further understood from Figures 7 and 8 that if the lens 402 is placed a distance  $s_o$  away from the incident electric field 408, the lens would provide an image of the electric field 408 at a distance  $s_i$  away with a magnification  $s_o/s_i$  (not shown).

Accordingly, the present invention detects an image of the Fourier transform of the bar code on the bead 102 at the Fourier plane, which appears as lines on a CCD camera (or code camera) in the Fourier plane. As a result, the reader 112 does not require expensive imaging optics to obtain an image of the bead 102.

In contrast, as shown in Figure 1, if the code on the bead 14 was detected by obtaining an image of the bead 14, e.g., if the code was simply as series of stripes printed on the bead 14, the reader/detector 20 would need to obtain a magnified image of the bead 14 with sufficient magnification to allow a code camera to read the stripes and thus obtain the code on the bead 14.

In this regard, if the appearance of the code on the bead looks like a bar code or digital code, the image in the Fourier plane will not look like the bar code or digital code, it will look like the Fourier transform of a bar code or digital code seen on the bead. Similarly, if the image of the code in the Fourier plane looks like a bar code or digital code, the appearance of the code on the bead will not likely look like a bar code or digital code because it will be the inverse Fourier transform of the bar code or digital code seen in the Fourier plane. Accordingly, it may be desirable to have the Fourier plane have a simple digital image that is easy to identify to keep the detector simple. In that case, the actual code on the bead itself will likely be unintelligible as a bar code or digital code.

## Figures 9-11: The Readout Beam

A technical requirement of the readout beam projected on the Fourier plane is that it must have a spatial coherence  $L_c$  large enough to resolve adjacent frequency components used to identify the object such as the microbead. Figure 9 shows the relationship between the spatial coherence length and two adjacent spatial frequencies (shown schematically on Figure 9.) The general requirement for the spatial coherence length is  $1/L_c < 1/\lambda_1 - 1/\lambda_2$ .

Figure 10 shows an example of the reflectivity of an object composed of the spatial frequency components shown in Figure 11. Information is contained in both the power amplitude and the spatial frequency of the Fourier components. A particularly robust method of identifying an object would be to look at the presence or absence of particular Fourier spatial frequencies, and choose a threshold to determine if a particular frequency corresponds to a logical "1" or a logical "0" (i.e. digital encoding.) If a threshold of 0.1 is chosen in the example of Figure 11, then the corresponding digital code would be 11011 for the five spatial frequencies analyzed.

## Scope of the Invention

The dimensions and/or geometries for any of the embodiments described herein are merely for illustrative purposes and, as such, any other dimensions and/or geometries may be used if desired, depending on the application, size, performance, manufacturing requirements, or other factors, in view of the teachings herein.

It should be understood that, unless stated otherwise herein, any of the features, characteristics, alternatives or modifications described regarding a particular embodiment herein may also be applied, used, or incorporated with any other embodiment described herein. Also, the drawings herein are not drawn to scale.

Although the invention has been described and illustrated with respect to exemplary embodiments thereof, the foregoing and various other additions and omissions may be made therein and thereto without departing from the spirit and scope of the present invention.

Moreover, the invention also comprises features of construction, combination of elements, and arrangement of parts which will be exemplified in the construction hereinafter set forth.

It will thus be seen that the objects set forth above, and those made apparent from the preceding

description, are efficiently attained and, since certain changes may be made in the above construction without departing from the scope of the invention, it is intended that all matter contained in the above description or shown in the accompanying drawing shall be interpreted as illustrative and not in a limiting sense.



WHAT IS CLAIMED IS:

1. A method for reading a microbead having a code thereon, wherein the code is projected on and read from a Fourier plane.

2. A method according to claim 1, wherein the code is projected on the Fourier plane by scattering input light off the microbead.

3. A method according to claim 1, wherein the code is read from the Fourier plane using a charge coupled device (CCD) or other suitable Fourier plane reading device.

4. A method according to claim 1, wherein a transform lens is arranged between the microbead and the Fourier plane at a distance of about one focal length  $f$  from each.

5. A method according to claim 1, wherein a Fourier plane transform processor performs Fourier plane analysis to determine the code from the resultant refractive index variation.

6. A method according to claim 1, wherein the code in the microbead takes the form of periodic layers of

material with different reflectivity, including material having different reflective spaces.

7. A method according to claim 1, wherein the code in the microbead takes the form of periodic layers of material having a different phase, including index of refraction differences; periodic spatial modulations having a different phase or amplitude; a periodic binary phase change used to code information in the Fourier plane; a photonic crystal used to encode the information on the microbead, wherein a pattern of holes causes interference between incident and scattered light to form spatial and spectral patterns in the far field that are unique to the pattern of holes; or the code may be formed in the microbead using a single photoactive inner region, a series of longitudinal holes, different fluorescence regions, or concentric rings of material in a preform.

8. A method according to claim 1, wherein the microbead is microscopic in size having a length in a range of 1-1,000 microns or smaller.

9. A method according to claim 1, wherein the microbead has a length of 1.0 - 1,000 millimeters or more.

10. A method according to claim 1, wherein the microbead has a substrate having a refractive index of an inner region less than or equal to its outer region.

11. A method according to claim 1, wherein the microbead may be encoded using any one of many different types of Fourier scattering techniques, including a single photoactive inner and/or outer region; a series of longitudinal holes; different fluorescence regions; or concentric rings of material in the preform.

12. A method according to claim 1, wherein the microbead may be encoded with Fourier scattering techniques using photonic crystal microparticles which encode information, where the pattern of the holes causes interferences between the incident and scattered light to form spatial and spectral patterns in the far field that are unique to the pattern of holes.

13. A method according to claim 1, wherein incident light provided to the microbead having a photonic crystal therein causes a radiation pattern and spectrum that uniquely encodes information that can be read using a Fourier plane analysis technique.

14. A method according to claim 1, wherein the

readout beam projected on the Fourier plane has a spatial coherence  $L_c$  large enough to resolve adjacent frequency components used to identify the microbead.

15. A method according to claim 14, wherein the method includes steps of identifying the microbead by looking at the presence or absence of particular Fourier spatial frequencies, and choosing a threshold to determine if a particular frequency corresponds to a logical "1" or a logical "0".

16. An optical arrangement for reading a microbead having a code thereon, wherein the code is projected on a Fourier plane and read by a Fourier plane reading device.

17. An optical arrangement according to claim 16, wherein the code is projected on the Fourier plane by scattering input light from a light source off the microbead.

18. An optical arrangement according to claim 16, wherein the code is read from the Fourier plane using a charge coupled device (CCD) or other suitable Fourier plane reading device.

19. An optical arrangement according to claim 16, wherein a transform lens is arranged between the microbead and the Fourier plane at a distance of about one focal length  $f$  from each.

20. An optical arrangement according to claim 16, wherein a Fourier plane transform processor performs Fourier plane analysis to determine the code from the resultant refractive index variation.

21. An optical arrangement according to claim 16, wherein the code in the microbead takes the form of periodic layers of material with different reflectivity, including material having different reflective spaces.

22. An optical arrangement according to claim 16, wherein the code in the microbead takes the form of periodic layers of material having a different phase, including index of refraction differences; periodic spatial modulations having a different phase or amplitude; a periodic binary phase change used to code information in the Fourier plane; a photonic crystal used to encode the information on the microbead, wherein a pattern of holes causes interference between incident and scattered light to form spatial and spectral patterns in the far field that are unique to the pattern of holes; or

the code may be formed in the microbead using a single photoactive inner region, a series of longitudinal holes, different fluorescence regions, or concentric rings of material in a preform.

23. An optical arrangement according to claim 16, wherein the microbead is microscopic in size having a length in a range of 1-1,000 microns or smaller.

24. An optical arrangement according to claim 16, wherein the microbead has a length of 1.0 - 1,000 millimeters or more.

25. An optical arrangement according to claim 16, wherein the microbead has a substrate having a refractive index of an inner region less than or equal to its outer region.

26. An optical arrangement according to claim 16, wherein the microbead may be encoded using any one of many different types of Fourier scattering techniques, including a single photoactive inner and/or outer region; a series of longitudinal holes; different fluorescence regions; or concentric rings of material in the preform.

27. An optical arrangement according to claim 16, wherein the microbead may be encoded with Fourier scattering techniques using photonic crystal microparticles which encode information, where the pattern of the holes causes interferences between the incident and scattered light to form spatial and spectral patterns in the far field that are unique to the pattern of holes.

28. An optical arrangement according to claim 16, wherein incident light provided to the microbead having a photonic crystal therein causes a radiation pattern and spectrum that uniquely encodes information that can be read using a Fourier plane analysis technique.

29. An optical arrangement according to claim 16, wherein the readout beam projected on the Fourier plane has a spatial coherence  $L_c$  large enough to resolve adjacent frequency components used to identify the microbead.

30. An optical arrangement according to claim 29, wherein the method includes steps of identifying the microbead by looking at the presence or absence of particular Fourier spatial frequencies, and choosing a threshold to determine if a particular frequency corresponds to a logical "1" or a logical "0".

31. A method according to claim 1, wherein the method further comprises implementing the step of the method via a computer program running in a processor, controller or other suitable module in an optical system.



1/8

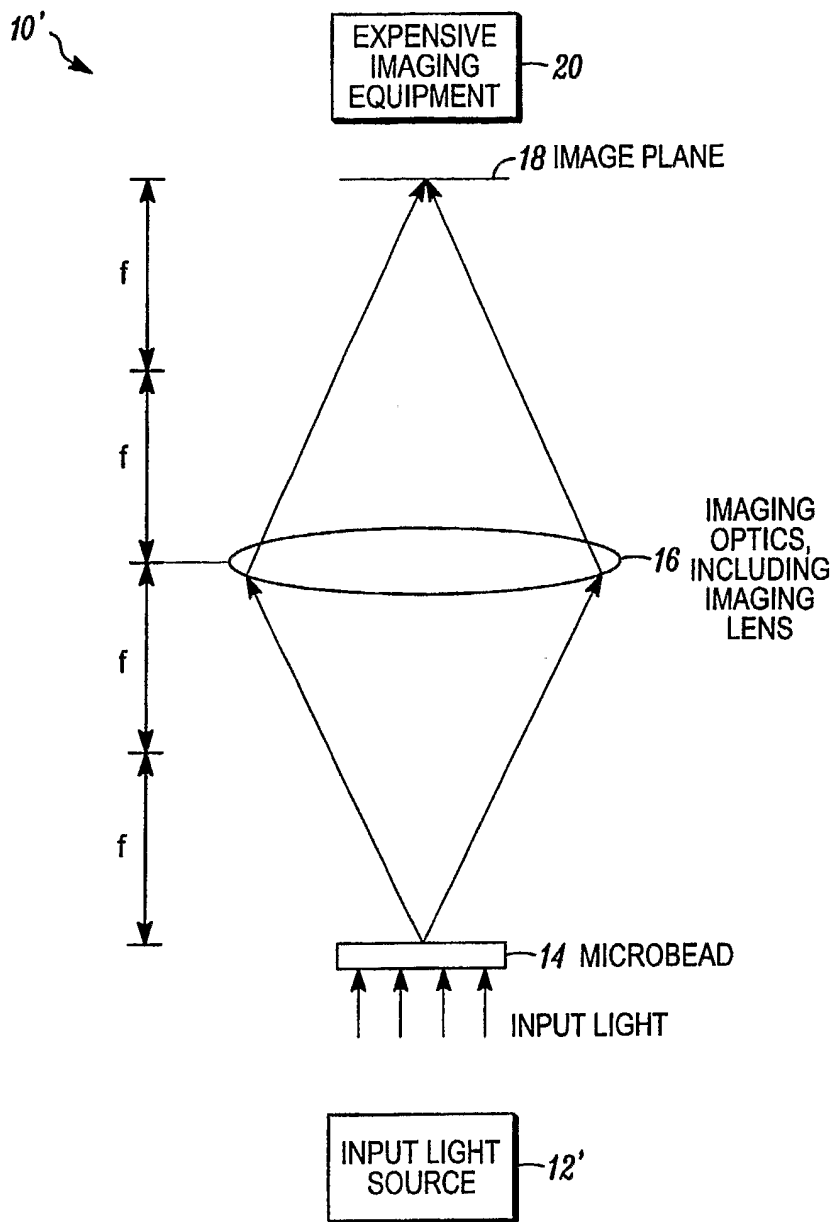

"SPATIAL IMAGE" TECHNIQUE OF READING AN ENCODED PARTICLE OR MICROBEAD THAT IS KNOWN IN THE PRIOR ART

FIG. 1

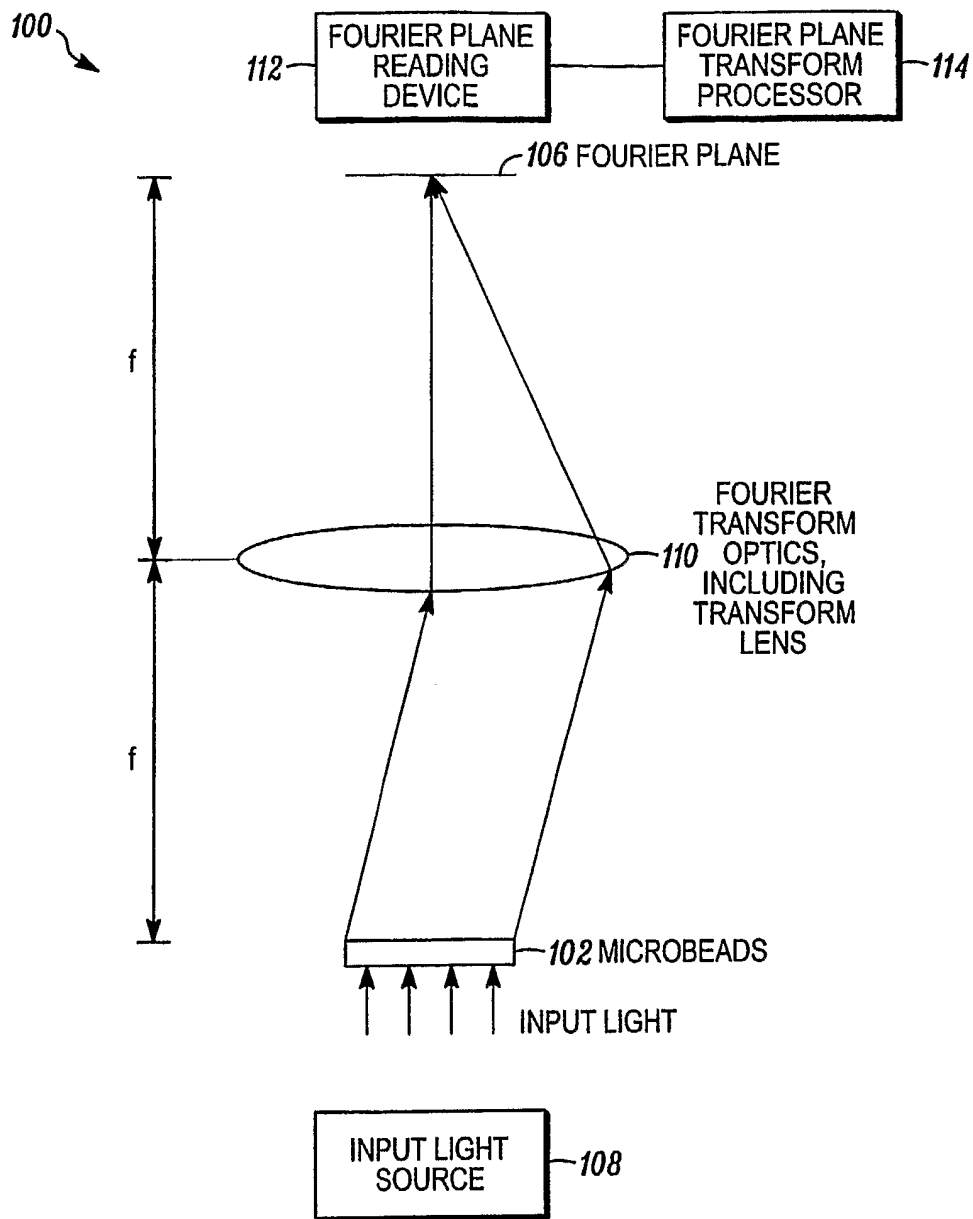

"FOURIER TRANSFORM" TECHNIQUE OF READING INFORMATION ENCODED IN A PARTICLE OR MICROBEAD

*FIG. 2*

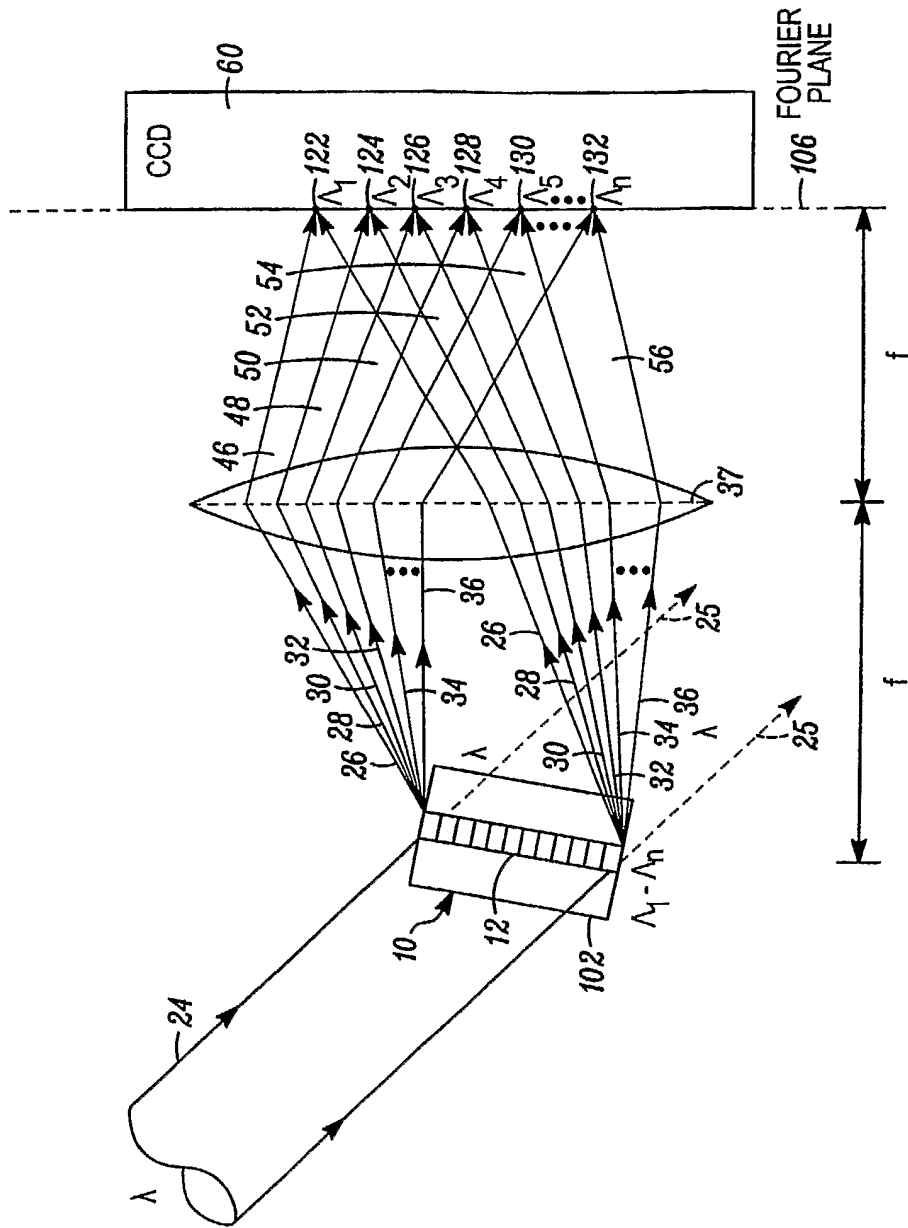
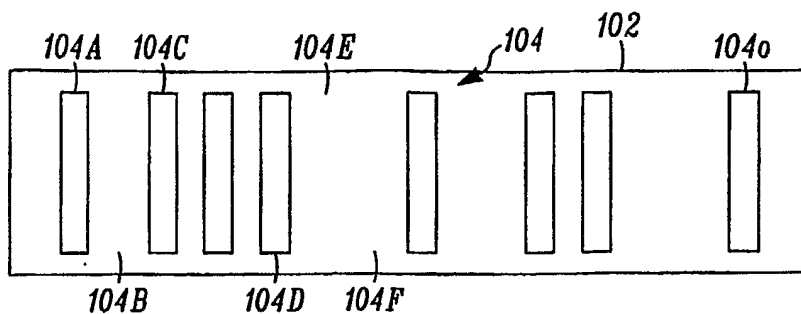
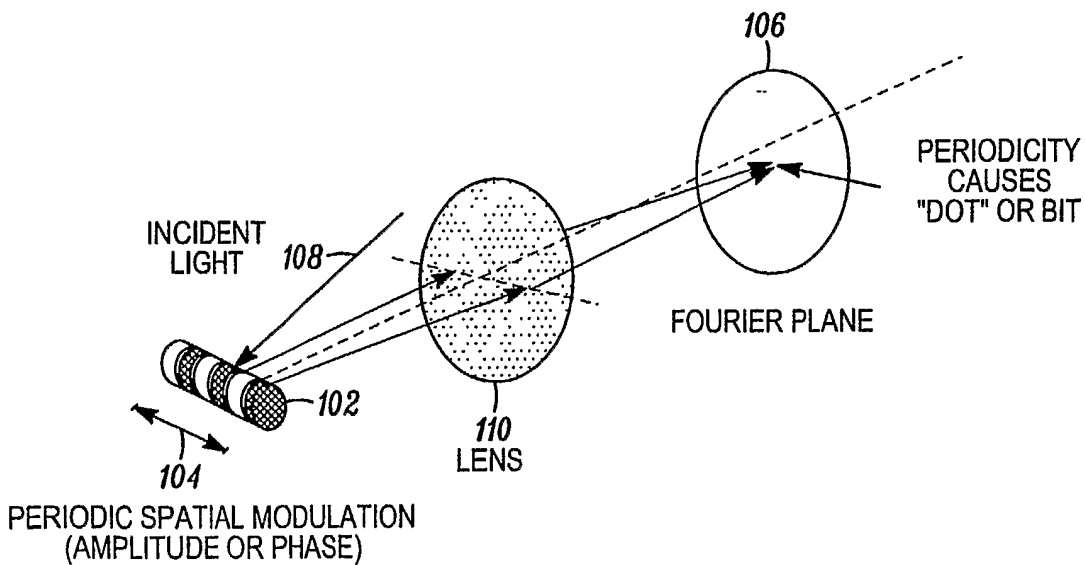

FIG. 2A



MICROBEAD INCLUDING CODE HAVING PERIODIC LAYERS OF MATERIAL WITH DIFFERENT REFLECTIVITY

FIG. 3



AN EXAMPLE OF A FOURIER PLANE READOUT OF A MULTILAYER METALLIC PARTICLE, WHICH OBIVIATES THE NEED FOR A HIGH RESOLUTION IMAGING SYSTEM

FIG. 4

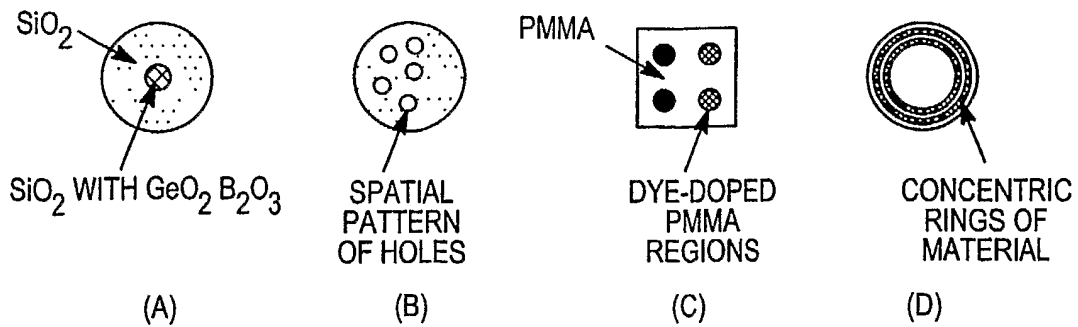

EXAMPLES OF ENCODED PARTICLE CROSS-SECTION BASED ON DIFFERENT CORE GEOMETRIES IN FILAMENT DRAWN AND CUT FROM A PREFORM TO FORM MICROBEADS

**FIG. 5**

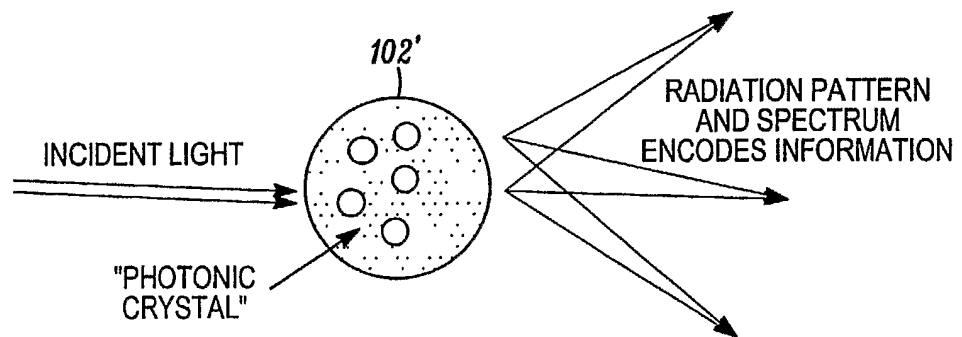

EXAMPLES OF FOURIER SCATTERING TECHNIQUES USING PHOTONIC CRYSTAL MICROPARTICLES WHICH ENCODE INFORMATION

**FIG. 6**

6/8

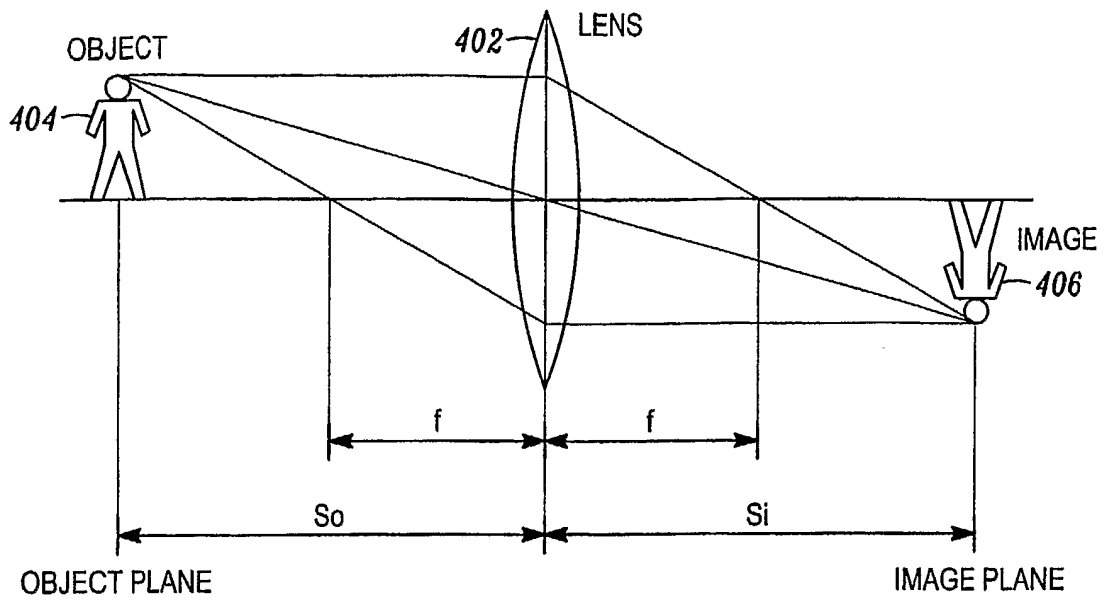

FIG. 7

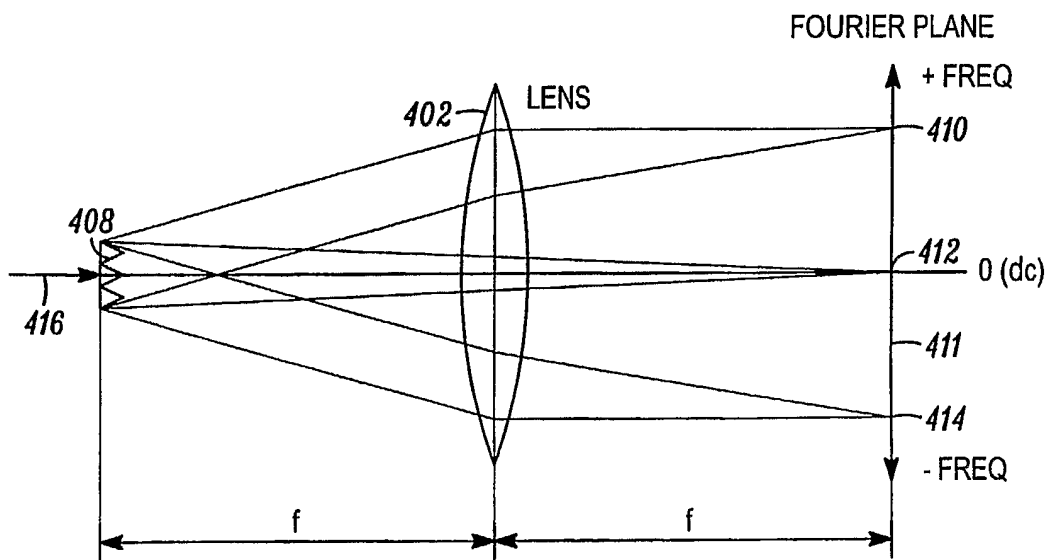
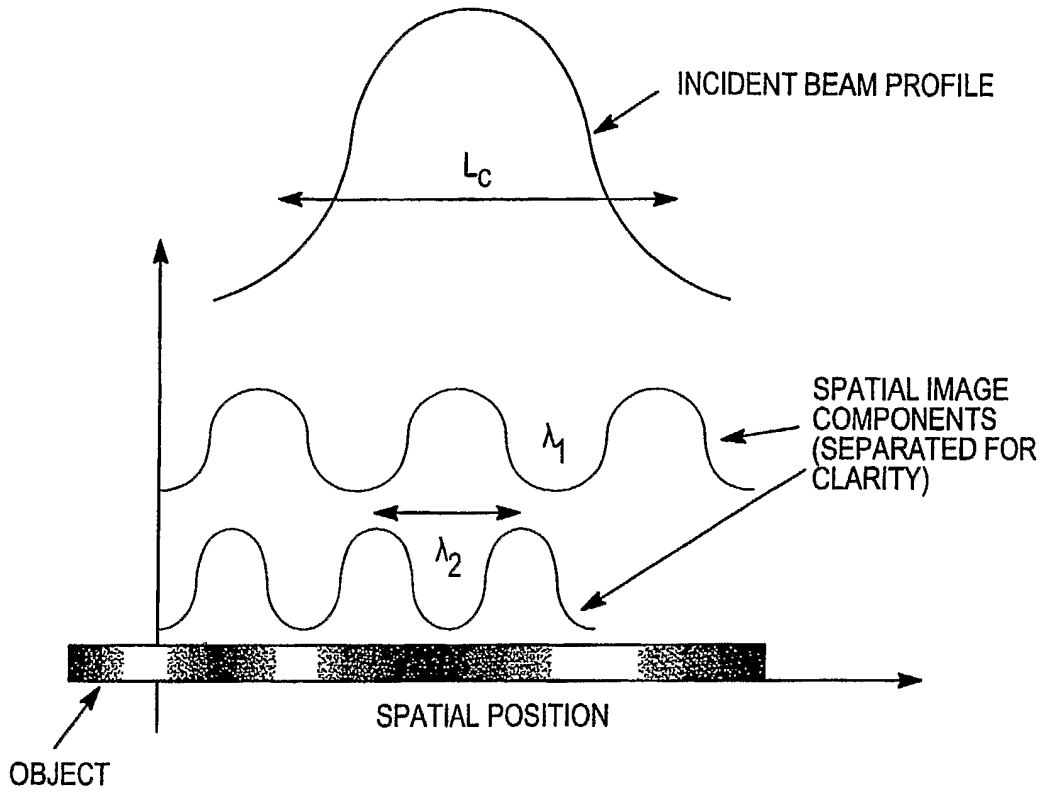

FIG. 8



*FIG. 9*

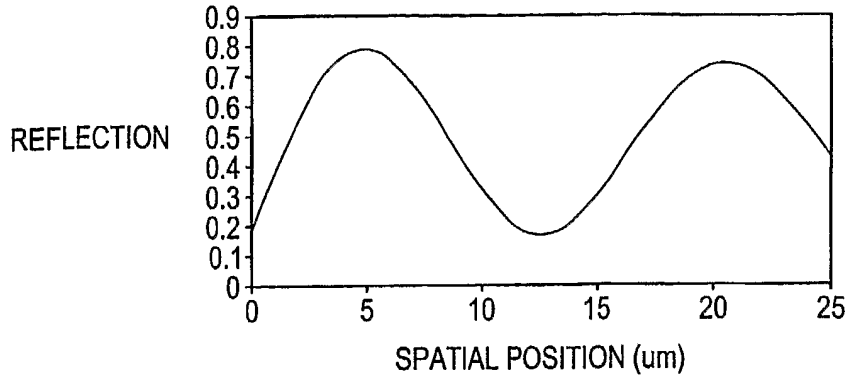

FIG. 10

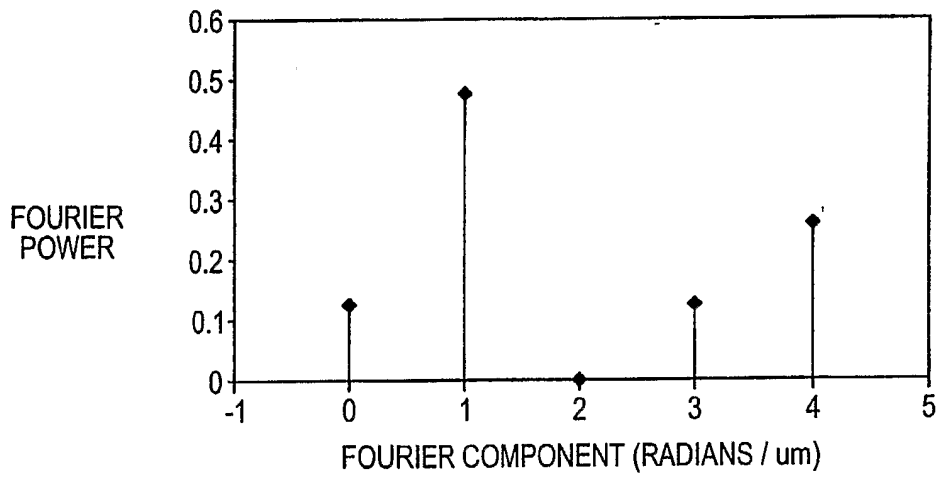

FIG. 11



# INTERNATIONAL SEARCH REPORT

International application No  
PCT/US2005/041731

**A. CLASSIFICATION OF SUBJECT MATTER**  
INV. G06K7/10

According to International Patent Classification (IPC) or to both national classification and IPC

**B. FIELDS SEARCHED**

Minimum documentation searched (classification system followed by classification symbols)  
G06K

Documentation searched other than minimum documentation to the extent that such documents are included in the fields searched

Electronic data base consulted during the international search (name of data base and, where practical, search terms used)

EPO-Internal, WPI Data, PAJ

**C. DOCUMENTS CONSIDERED TO BE RELEVANT**

Category*	Citation of document, with indication, where appropriate, of the relevant passages	Relevant to claim No.
X	WO 2004/019276 A (CIDRA CORPORATION; CYVERA CORPORATION) 4 March 2004 (2004-03-04) the whole document -----	1-31

Further documents are listed in the continuation of Box C.

See patent family annex.

\* Special categories of cited documents :

- "A" document defining the general state of the art which is not considered to be of particular relevance
- "E" earlier document but published on or after the international filing date
- "L" document which may throw doubts on priority claim(s) or which is cited to establish the publication date of another citation or other special reason (as specified)
- "O" document referring to an oral disclosure, use, exhibition or other means
- "P" document published prior to the international filing date but later than the priority date claimed

- "T" later document published after the international filing date or priority date and not in conflict with the application but cited to understand the principle or theory underlying the invention
- "X" document of particular relevance; the claimed invention cannot be considered novel or cannot be considered to involve an inventive step when the document is taken alone
- "Y" document of particular relevance; the claimed invention cannot be considered to involve an inventive step when the document is combined with one or more other such documents, such combination being obvious to a person skilled in the art.
- "&" document member of the same patent family

Date of the actual completion of the international search

10 April 2006

Date of mailing of the international search report

21/04/2006

Name and mailing address of the ISA/  
European Patent Office, P.B. 5818 Patentlaan 2  
NL - 2280 HV Rijswijk  
Tel. (+31-70) 340-2040, Tx. 31 651 epo nl,  
Fax: (+31-70) 340-3016

Authorized officer

Schmidt, R

# INTERNATIONAL SEARCH REPORT

International application No  
PCT/US2005/041731

Patent document cited in search report	Publication date	Patent family member(s)	Publication date
WO 2004019276	A	AU 2003265583 A1	11-03-2004
		AU 2003265584 A1	11-03-2004
		CA 2496287 A1	04-03-2004
		CA 2496296 A1	04-03-2004
		EP 1535241 A1	01-06-2005
		EP 1535242 A1	01-06-2005
		JP 2005536769 T	02-12-2005
		JP 2005536725 T	02-12-2005
		WO 2004019277 A1	04-03-2004

---