

(Model.)

S. W. UNDERHILL.
Furnace and Boiler.

2 Sheets—Sheet 1.

No. 235,659.

Patented Dec. 21, 1880.

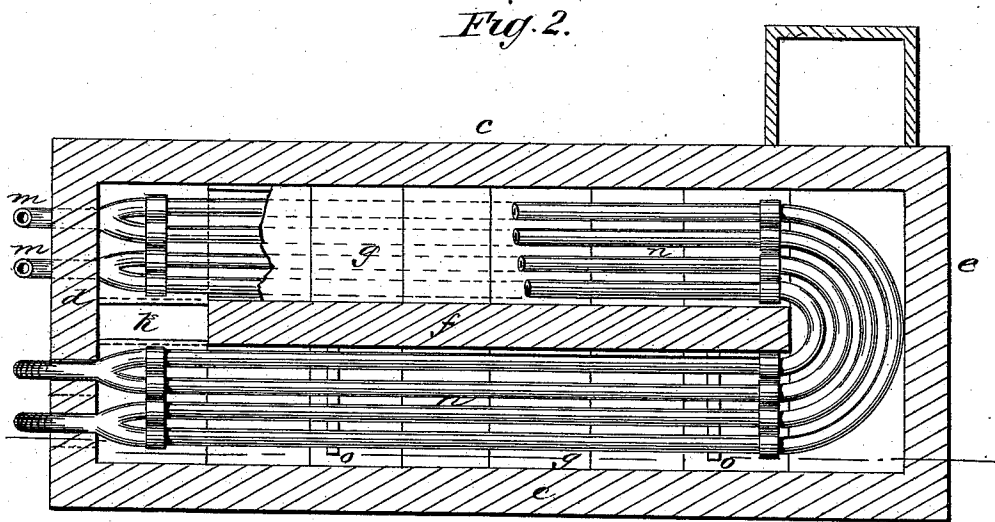
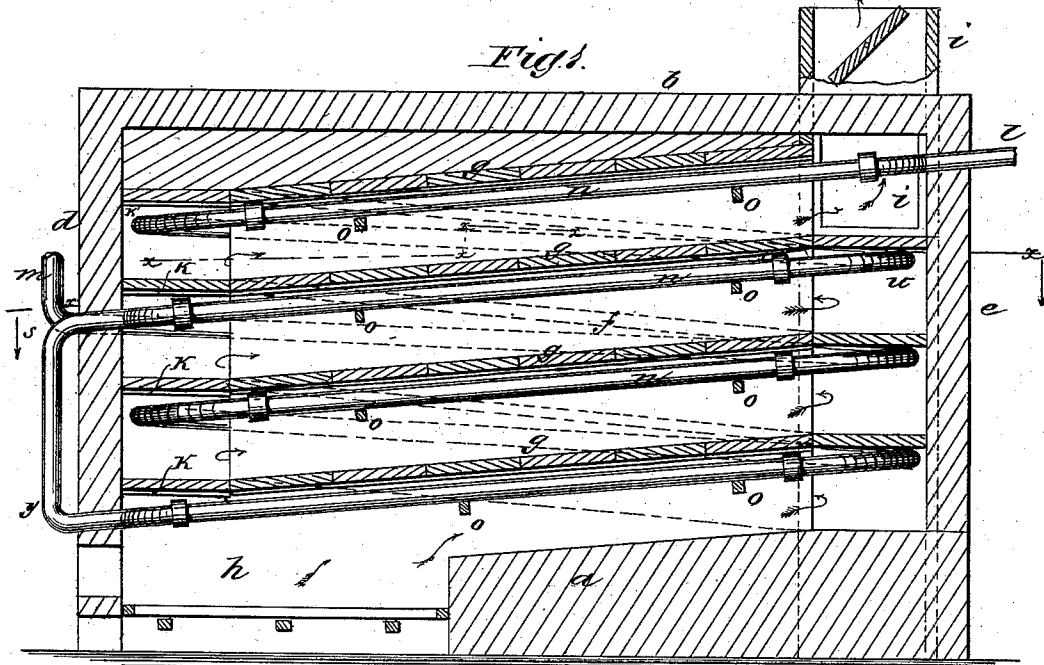

WITNESSES:
Francis McCarde.
C. Sedgwick

INVENTOR:
S. W. Underhill
BY *Henry H. [Signature]*
ATTORNEYS.

(Model.)

S. W. UNDERHILL.
Furnace and Boiler.

2 Sheets—Sheet 2.

No. 235,659.

Patented Dec. 21, 1880.

Fig. 3.

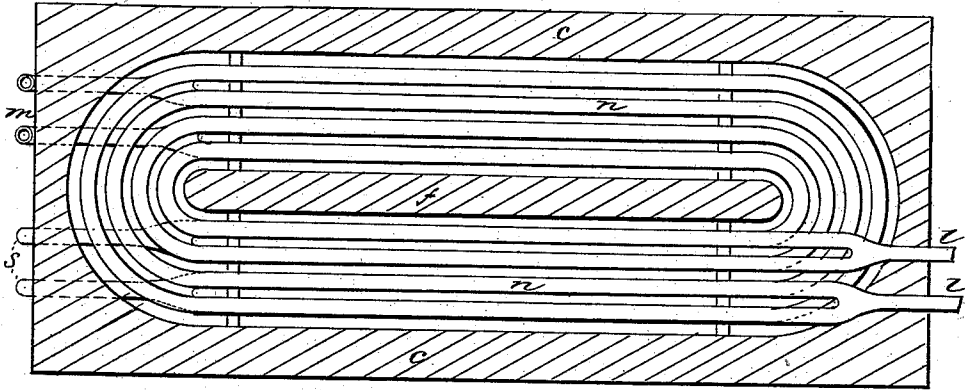

Fig. 4.

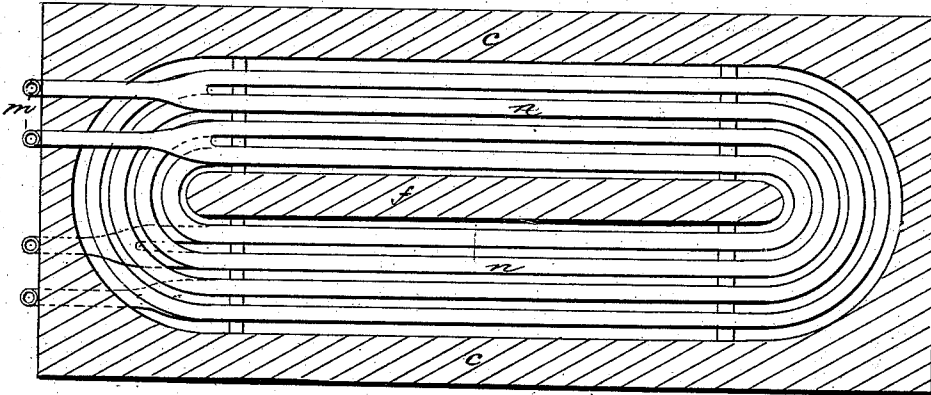
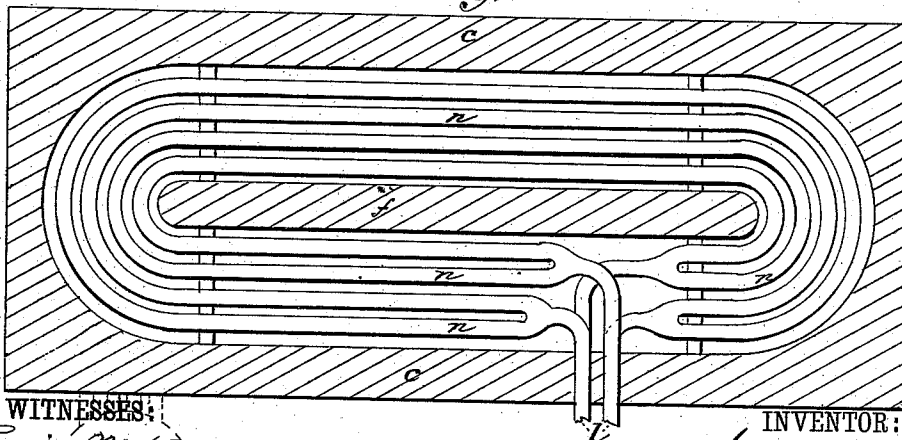

Fig. 5.



WITNESSES:

Francis McArdle
C. Sedgwick

INVENTOR:

S. W. Underhill
BY *Mum & Co*

ATTORNEYS.

UNITED STATES PATENT OFFICE.

STEPHEN W. UNDERHILL, OF CROTON LANDING, NEW YORK.

FURNACE AND BOILER.

SPECIFICATION forming part of Letters Patent No. 235,659, dated December 21, 1880.

Application filed March 1, 1880. (Model.)

To all whom it may concern:

Be it known that I, STEPHEN W. UNDERHILL, of Croton Landing, in the county of Westchester and State of New York, have invented a new and useful Improvement in Furnaces and Boilers, of which the following is a specification.

My improvement relates to boilers and furnaces for hot-water heating apparatus and steam-generators, and have for their object economy of fuel, rapidity and uniformity of action, requiring but little attention, and capable of being run very slowly.

These objects are obtained, first, by comparatively perfect combustion of the fuel; second, extended heating-surface, which is continued a long distance from the fire-box; third, by the absorption of heat to be given out when the fire declines, fourth, by the exposure of the pipes containing the coolest water to the coolest draft.

I make use of a brick furnace divided longitudinally by a vertical wall and by tiles placed between the central and side walls, forming a continuous spiral flue from the fire-box to the chimney. Through the spiral flue the tubes containing water pass.

The construction and operation will be more particularly described with reference to the accompanying drawings, and the invention pointed out in the claims.

In the drawings, Figure 1 is a vertical longitudinal section of my furnace and boiler. Fig. 2 is a sectional plan view on line *x x* of Fig. 1. Fig. 3 is a plan of the upper portion of the boiler, as shown, by removing the wall *b* and tiles *g* down to the line *x x*, Fig. 1, showing the arrangement of the tubes in the upper portion of the boiler to the point where they pass out through the front wall. Fig. 4 is a plan showing the tubes in the lower portion of the boiler, as seen below a horizontal cross-section on the line *x x*, Fig. 1, by removing the tiles *g* below this line and the tubes of the upper portion of the boiler. Fig. 5 is a plan view of a modification of the arrangement of the tubes in the upper portion of the boiler, in which a single coil of pipe only is employed and the inlet and outlet pipes are arranged to enter the side wall of the furnace close together and arranged one above the other. The cir-

culaton of the water in the pipe will be the same in the arrangement shown in this figure as that described in the arrangement of pipes shown in the other figures.

Similar letters of reference indicate corresponding parts.

The bottom *a*, top *b*, side walls, *c*, and front and rear walls, *d e*, are of brick, sufficiently thick to prevent radiation of heat.

The inclosed space is divided lengthwise by a middle wall, *f*, which extends from top to bottom, but short of the front and rear walls.

Between the side walls, *c*, and the middle wall, *f*, there are fitted horizontal partitions of tiling, inclined in opposite directions at opposite sides of wall *f*, and united at the ends of the wall, so as to form a continuous spiral or back-and-forth flue from the fire-box *h* to the chimney *i*. The tiles forming the partitions are to be supported by offsets formed upon the sides and middle walls, so that the tiles may be removed without disturbing the side and middle walls when repairs are needed in the tubing, and the tiles connecting the ends rest on the metal bars *k*, that are set in the end walls, *d e*, and wall *f*.

The rear wall, *e*, and front wall, *d*, will preferably be formed with openings between the ends of the partitions to give access for cleaning the flues, and these openings will be filled with loose brick sealed with clay instead of iron doors, which radiate heat.

The fire-box *h* is fitted with grate-bars, as usual, and it will be seen that the products of combustion are compelled to pass back and forth in contact with the side and center wall of the furnace, so that the whole stack becomes heated, while the tubes which are arranged in the flue as next described are in direct contact with the heated gases.

The tubes *l*, entering through the rear wall at the base of the chimney *i*, are the feed-water tubes or the return-pipes of the heating apparatus, and the pipes *m* are the tubes for delivery of hot water. There are two tubes, *l*, Fig. 3, which are forked within the flue and coupled with the tubes *n*, that pass through the descending spiral flue, following said flue for one and a half turn, where it passes out through the front wall at *s*, Fig. 3, thence down to *j*, a point over the fire-door, thence in through

the front wall into the fire-box, Fig. 1, thence through the upward spiral flue, Figs. 1 and 4, nearly two complete turns, thence out through the front wall at *m*, the point of discharge of the hot water.

The tubes *n* are supported upon cross-bars *o*, that are set in the walls of the furnace.

As shown, the cold feed-water enters the flue at the place of the least heat, and passes in a direction opposite to the current in the flue one and a half turn or any desirable distance, and thence out through the front wall. By this means the draft in the upper portion of the flue is continually coming in contact with the tubes containing cooler and cooler water, until it is discharged into the chimney. Consequently the greatest possible amount of heat is extracted from it. The tubes, after passing through the front wall, turn down to the fire-box and in over the fire and through the lower highly-heated flues. By this plan the water which was warmed in the upper portion of the flue is rapidly heated to the desired point before passing out at *m*.

This construction utilizes a large proportion of the heat from the fuel—

First, by reason of the long flue-space, allowing of ample time, as well as surface, for the absorption of heat.

Second, by the perfect combustion of the fuel caused by the small amount of water-surface in the fire-box and flue adjacent, allowing these to become sufficiently heated to burn the gases from the coal. When soft coal is used the supports *o* of the tubes *n* in the fire-box and adjacent flue are made of cast-iron pipe, perforated with small holes. The end

of said pipes passing through the side walls allows the access of fresh air to the fire-box and flue, causing the smoke and gases to be consumed.

Third, by the slow combustion which is permitted by storing the surplus heat.

Fourth, by exposing tubes containing the coolest water to the coolest draft.

Owing to the perfect combustion the accumulation of acid and soot is avoided, causing the tubes to last much longer, so that the apparatus is very durable.

Having thus described my invention, I claim as new and desire to secure by Letters Patent—

1. In water-heaters, the combination, with furnace-stack, of the middle wall, *f*, and inclined partitions *g*, forming a continuous flue, and the tubes *l*, *m*, and *n*, substantially as shown and described.

2. In a water-heater provided with a continuous flue connecting the fire-box and chimney, fitted with water-pipes within the flue, substantially as set forth, to allow the cool return-water to flow down the pipes which enter the flue near the chimney in a direction opposite to the draft within the flue a desirable distance, thence out through the wall of the flue to enter the fire-box or flue near it, and pass up in the direction of the draft to a point near where it previously left said flue, thence passing out through the wall.

STEPHEN W. UNDERHILL.

Witnesses:

GEO. D. WALKER,
C. SEDGWICK.