

CORRECTED VERSION

(19) World Intellectual Property Organization
International Bureau



(43) International Publication Date
7 August 2008 (07.08.2008)

PCT

(10) International Publication Number
WO 2008/095029 A2

- (51) **International Patent Classification:**
E21B 21/06 (2006.01) *B63B 27/00* (2006.01)
E21B 21/00 (2006.01)
- (21) **International Application Number:**
PCT/US2008/052512
- (22) **International Filing Date:** 30 January 2008 (30.01.2008)
- (25) **Filing Language:** English
- (26) **Publication Language:** English
- (30) **Priority Data:**
60/887,442 31 January 2007 (31.01.2007) US
12/020,402 25 January 2008 (25.01.2008) US
- (71) **Applicant (for all designated States except US):** M-ILLC [US/US]; 5950 North Course Drive, Houston, TX 77072 (US).
- (72) **Inventors; and**
- (75) **Inventors/Applicants (for US only):** EIA, Jan, Thore [NO/NO]; Haabakken 4, N-4355 Kvernaland (NO). LOGAN, Gordon, M. [GB/GB]; 13 Devanha Gardens, Aberdeen AB11 7UU (GB).
- (74) **Agents:** BERGMAN, Jeffrey, S. et al.; Osha - Liang LLP, 1221 McKinney St., Suite 2800, Houston, TX 77010 (US).
- (81) **Designated States (unless otherwise indicated, for every kind of national protection available):** AE, AG, AL, AM, AO, AT, AU, AZ, BA, BB, BG, BH, BR, BW, BY, BZ, CA, CH, CN, CO, CR, CU, CZ, DE, DK, DM, DO, DZ, EC, EE, EG, ES, FI, GB, GD, GE, GH, GM, GT, HN, HR, HU, ID, IL, IN, IS, JP, KE, KG, KM, KN, KP, KR, KZ, LA, LC, LK, LR, LS, LT, LU, LY, MA, MD, ME, MG, MK, MN, MW, MX, MY, MZ, NA, NG, NI, NO, NZ, OM, PG, PH, PL, PT, RO, RS, RU, SC, SD, SE, SG, SK, SL, SM, SV, SY, TJ, TM, TN, TR, TT, TZ, UA, UG, US, UZ, VC, VN, ZA, ZM, ZW.
- (84) **Designated States (unless otherwise indicated, for every kind of regional protection available):** ARIPO (BW, GH, GM, KE, LS, MW, MZ, NA, SD, SL, SZ, TZ, UG, ZM, ZW), Eurasian (AM, AZ, BY, KG, KZ, MD, RU, TJ, TM), European (AT, BE, BG, CH, CY, CZ, DE, DK, EE, ES, FI, FR, GB, GR, HR, HU, IE, IS, IT, LT, LU, LV, MC, MT, NL, NO, PL, PT, RO, SE, SI, SK, TR), OAPI (BF, BJ, CF, CG, CI, CM, GA, GN, GQ, GW, ML, MR, NE, SN, TD, TG).
- Declarations under Rule 4.17:**
— as to applicant's entitlement to apply for and be granted a patent (Rule 4.17(ii))
— as to the applicant's entitlement to claim the priority of the earlier application (Rule 4.17(iii))

[Continued on next page]

(54) **Title:** USE OF CUTTINGS TANK FOR SLURRIFICATION ON DRILLING RIG

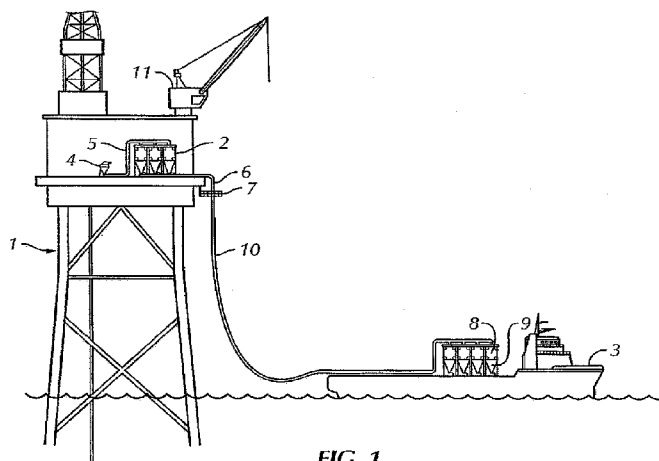

FIG. 1

(57) **Abstract:** A system for preparing slurry on a rig including a first cuttings storage vessel, a module, and a fluid supply line in fluid communication with the first cuttings storage vessel, the module including a grinding device configured to facilitate the transfer of fluids, an inlet connection configured to connect to an outlet of the first cuttings storage vessel, and an outlet connection configured to connect to an inlet of the first cuttings storage vessel is disclosed. A method of operating a slurrification system including using a first vessel for cuttings storage and operating the first vessel in a slurrification process is also disclosed. A method of transferring material from a work site to a transport vehicle, the method including transferring a first material from a first cuttings storage vessel disposed at the work site to a cuttings storage assembly disposed on the transport vehicle, and transferring a second material from a second cuttings storage vessel disposed at the work site to the cuttings storage assembly disposed on the transport vehicle, wherein the transferring of the first material and the transferring of the second material occurs contemporaneously, and wherein the first material comprises dry cuttings and the second material comprises a fluid is also disclosed.

WO 2008/095029 A2



Published:

— *without international search report and to be republished upon receipt of that report*

(15) Information about Correction:

see Notice of 18 September 2008

(48) Date of publication of this corrected version:

18 September 2008

USE OF CUTTINGS TANK FOR SLURRIFICATION ON DRILLING RIG

BACKGROUND

Field of the Invention

[0001] Embodiments disclosed herein relate generally to a system for slurrification of drill cuttings on a drill rig. More particularly, embodiments disclosed herein relate to a slurrification system and method of operating the slurrification system that includes connecting a module to a cuttings storage vessel disposed on a rig.

Background Art

[0002] In the drilling of wells, a drill bit is used to dig many thousands of feet into the earth's crust. Oil rigs typically employ a derrick that extends above the well drilling platform. The derrick supports joint after joint of drill pipe connected end-to-end during the drilling operation. As the drill bit is pushed further into the earth, additional pipe joints are added to the ever lengthening "string" or "drill string". Therefore, the drill string typically includes a plurality of joints of pipe.

[0003] Fluid "drilling mud" is pumped from the well drilling platform, through the drill string, and to a drill bit supported at the lower or distal end of the drill string. The drilling mud lubricates the drill bit and carries away well cuttings generated by the drill bit as it digs deeper. The cuttings are carried in a return flow stream of drilling mud through the well annulus and back to the well drilling platform at the earth's surface. When the drilling mud reaches the platform, it is contaminated with small pieces of shale and rock that are known in the industry as well cuttings or drill cuttings. Once the drill cuttings, drilling mud, and other waste reach the platform, a "shale shaker" is typically used to remove the drilling mud from the drill cuttings so that the drilling mud may be reused. The remaining drill cuttings, waste, and residual drilling mud are then transferred to a holding trough for disposal. In some situations, for example with specific types of drilling mud, the drilling mud may not be reused and it must be disposed. Typically, the non-recycled drilling mud is disposed of separate from the drill cuttings and other waste by transporting the drilling mud via a vessel to a disposal site.

[0004] The disposal of the drill cuttings and drilling mud is a complex environmental problem. Drill cuttings contain not only the residual drilling mud product that would contaminate the surrounding environment, but may also contain oil and other waste that is particularly hazardous to the environment, especially when drilling in a marine environment.

[0005] In the Gulf of Mexico, for example, there are hundreds of drilling platforms that drill for oil and gas by drilling into the subsea floor. These drilling platforms may be used in places where the depth of the water is many hundreds of feet. In such a marine environment, the water is typically filled with marine life that cannot tolerate the disposal of drill cuttings waste. Therefore, there is a need for a simple, yet workable solution to the problem of disposing of well drill cuttings, drilling mud, and/or other waste in offshore marine environments and other fragile environments.

[0006] Traditional methods of disposal include dumping, bucket transport, cumbersome conveyor belts, screw conveyors, and washing techniques that require large amounts of water. Adding water creates additional problems of added volume and bulk, pollution, and transport problems. Installing conveyors requires major modification to the rig area and involves extensive installation hours and expense.

[0007] Another method of disposal includes returning the drill cuttings, drilling mud, and/or other waste via injection under high pressure into an earth formation. In general, the injection process involves the preparation of a slurry within surface-based equipment, and pumping the slurry into a well that extends relatively deep underground into a receiving stratum or adequate formation. The basic steps in the process include the identification of an appropriate stratum or formation for the injection; preparing an appropriate injection well; formulation of the slurry, which includes considering such factors as weight, solids content, pH, gels, etc.; performing the injection operations, which includes determining and monitoring pump rates such as volume per unit time and pressure; and capping the well.

[0008] Material to be injected back into a formation must be prepared into a slurry acceptable to high pressure pumps used in pumping material down a well. The particles are usually not uniform in size and density, thus making the slurrification process complicated. If the slurry is not the correct density, the slurry often plugs

circulating pumps. The abrasiveness of the material particles may also abrade the pump impellers causing cracking. Some centrifugal pumps may be used for grinding the injection particles by purposely causing pump cavitation.

[0009] In some instances, the cuttings, which are still contaminated with some oil, are transported from a drilling rig to an offshore rig or ashore in the form of a thick heavy paste or slurry for injection into an earth formation. Typically the material is put into special skips of about 10 ton capacity that are loaded by crane from the rig onto supply boats. This may be a difficult and dangerous operation that may be laborious and expensive.

[0010] U.S. Patent No. 6,709,216 and related patent family members disclose that cuttings may also be conveyed to and stored in an enclosed, transportable vessel, where the vessel may then be transported to a destination, and the drill cuttings may be withdrawn. The transportable storage vessel has a lower conical section structured to achieve mass flow of the mixture in the vessel, and withdrawal of the cuttings includes applying a compressed gas to the cuttings in the vessel. The transportable vessels are designed to fit within a 20 foot ISO container frame. These conical vessels will be referred to herein as ISO vessels.

[0011] As described in U.S. Patent No. 6,709,216 and family, the ISO vessels may be lifted onto a drilling rig by a rig crane and used to store cuttings. The vessels may then be used to transfer the cuttings onto a supply boat. The cuttings may be transferred by pipe lines or, alternatively, the storage vessels containing cuttings may be lifted off the rig by cranes and transported by a supply boat. When a supply boat is not present, the vessels may also serve as buffer storage.

[0012] Space on offshore platforms is limited. In addition to the storage and transfer of cuttings, many additional operations take place on a drilling rig, including tank cleaning, slurrification operations, drilling, chemical treatment operations, raw material storage, mud preparation, mud recycle, mud separations, and others.

[0013] Due to the limited space, it is common to modularize these operations and to swap out modules when not needed or when space is needed for the equipment. For example, cuttings containers may be offloaded from the rig to make room for modularized equipment used for slurrification. These lifting operations, as mentioned

above, may be difficult, dangerous, and expensive. Additionally, many of these modularized operations are self contained, and therefore, include redundant equipment, such as pumps, valves, and tanks or storage vessels.

[0014] Slurrification systems may be disposed in portable units that may be transported from one work site to another. As disclosed in U.S. Patent No. 5,303,786, a slurrification system may be mounted on a semi-trailer that may be towed between work sites. The system includes, *inter alia*, multiple tanks, pumps, mills, grinders, agitators, hoppers, and conveyors. As discussed in U.S. Patent No. 5,303,786, the slurrification system may be moved to a site where a large quantity of material to be treated is available, such as existing or abandoned reserve pits that hold large quantities of cuttings.

[0015] Slurrification systems that may be moved onto a rig are typically large modules that are fully self-contained, receiving cuttings from a drilling rig's fluid mud recovery system. For example, PCT Publication No. WO 99/04134 discloses a process module containing a first slurry tank, grinding pumps, a system shale shaker, a second slurry tank, and optionally a holding tank. The module may be lifted by a crane on to an offshore drilling platform. While these systems and methods provide improved processes in slurrification and re-injection systems, they require difficult, dangerous, and expensive lifting and installation operations, as described above.

[0016] Accordingly, there exists a continuing need for systems and methods for efficiently preparing slurries for re-injection at a drilling location.

SUMMARY OF INVENTION

[0017] In one aspect, embodiments disclosed herein relate to a system for preparing slurry on a rig including a first cuttings storage vessel, a module, and a fluid supply line in fluid communication with the first cuttings storage vessel, the module including a grinding device configured to facilitate the transfer of fluids, an inlet connection configured to connect to an outlet of the first cuttings storage vessel, and an outlet connection configured to connect to an inlet of the first cuttings storage vessel.

- [0018] In another aspect, embodiments disclosed herein relate to a module including a grinding device configured to facilitate the transfer of fluids, an inlet connection configured to connect to an outlet of a first cuttings storage vessel disposed on a rig, and an outlet connection configured to connect to an inlet of the first cuttings storage vessel.
- [0019] In another aspect, embodiments disclosed herein relate to a method of operating a slurrification system including using a first vessel for cuttings storage and operating the first vessel in a slurrification process.
- [0020] In yet another embodiment, embodiments disclosed herein relate to a method of transferring material from a work site to a transport vehicle, the method including transferring a first material from a first cuttings storage vessel disposed at the work site to a cuttings storage assembly disposed on the transport vehicle, and transferring a second material from a second cuttings storage vessel disposed at the work site to the cuttings storage assembly disposed on the transport vehicle, wherein the transferring of the first material and the transferring of the second material occurs contemporaneously, and wherein the first material comprises dry cuttings and the second material comprises a fluid.
- [0021] Other aspects and advantages of embodiments disclosed herein will be apparent from the following description and the appended claims.

BRIEF DESCRIPTION OF DRAWINGS

- [0022] Figure 1 shows a method of offloading drill cuttings from an off-shore rig in accordance with an embodiment of the present disclosure.
- [0023] Figure 2 shows a top view of a system for transferring material from an off-shore rig in accordance with an embodiment of the present disclosure.
- [0024] Figure 3 shows a slurrification system in accordance with embodiments of the present disclosure.
- [0025] Figure 4 shows a grinding device in accordance with embodiments of the present disclosure.

[0026] Figure 5 shows a slurrification system in accordance with embodiments of the present disclosure.

[0027] Figure 6 shows a slurrification system in accordance with embodiments of the present disclosure.

DETAILED DESCRIPTION

[0028] In one aspect, embodiments of the present disclosure relate to a system for preparing a slurry on a rig, including a module configured to be connected to at least one cuttings storage vessel on the rig. In another aspect, embodiments of the present disclosure relate to a module that includes a grinding device and inlet and outlet connections configured to connect to an outlet and an inlet of a cuttings storage vessel disposed on the rig. In another aspect, embodiments of the present disclosure relate to a method of operating a slurrification system that includes using a vessel for cutting storage, and using the same vessel for a slurrification process. In yet another aspect, embodiments disclosed herein relate to a method of converting a cuttings storage vessel for use in a slurrification process by connecting a module, as disclosed in embodiments herein, to the cuttings storage vessel.

[0029] Referring initially to Figure 1, a method of offloading drill cuttings from an off-shore drilling rig according to one embodiment of the present disclosure is shown. In this embodiment, an offshore oil rig 1 may have one or more cuttings storage vessels 2 located on its platform. Cuttings storage vessels 2 may include raw material storage tanks, waste storage tanks, or any other vessels commonly used in association with drilling processes. Specifically, cuttings storage vessels 2 may include cuttings boxes, ISO-tanks, and pneumatic conveying vessels. In some embodiments, cuttings storage vessels 2 may include several individual vessels connected to allow the transference of cuttings therebetween. Such cuttings storage vessels 2 may be located within a support framework (not shown), such as an ISO container frame. As such, those of ordinary skill in the art will appreciate that cuttings storage vessels 2 may be used for both drill cuttings storage and transport.

[0030] As described above with respect to prior art methods, when cuttings storage vessels 2 are no longer needed during a drilling operation, or temporarily not required for operations taking place on the drilling rig, cuttings storage vessels 2 may be

offloaded to a transport vehicle, for example, a supply boat 3. Other systems and vessels for performing different operations may then be lifted onto the rig via crane 11, and placed where vessels 2 were previously located. In this manner, valuable rig space may be saved; however, conserving space in this manner may require many dangerous and costly crane lifts.

[0031] In contrast to the prior art methods describe above, embodiments disclosed herein integrate vessels 2 into two or more operations that are performed on drilling rig 1. In one aspect, embodiments disclosed herein relate to integrating cuttings storage vessels 2 to operate in at least two operations on rig 1. In some aspects, embodiments disclosed herein relate to integrating cuttings storage vessels 2 to be used for cuttings storage and/or transport, as well a second operation performed on a rig. More specifically, embodiments disclosed herein relate to using cuttings storage vessels 2 as both a storage/transfer vessel, as well as a component in a slurrification system. Although described with respect to integrating cuttings storage vessels into a slurrification system, one skilled in the art will appreciate that any vessel located on a rig platform or other drilling location for a given operation may be integrated into the systems and methods for slurrification disclosed herein.

[0032] Referring still to Figure 1, offshore oil rig 1 may include one or more cuttings storage vessels 2 located on its platform. Drill cuttings generated during the drilling process may be transferred to cuttings storage vessels 2 for storage and/or subsequent transfer in a number of different ways. One such method of transferring drill cuttings is via a pneumatic transfer system including a cuttings blower 4 and pneumatic transfer lines 5. Examples of systems using forced flow pneumatic transfer are disclosed in U.S. Patent Nos. 6,698,989, 6,702,539, and 6,709,216, all incorporated by reference herein. However, those of ordinary skill in the art will appreciate that other methods for transferring cuttings from a separatory or cleaning operation (*e.g.*, using vibratory separators) to cuttings storage vessels 2 may include augers, conveyors, and pneumatic suction or vacuum systems.

[0033] In a system using pneumatic cuttings transfer, when cuttings need to be offloaded from rig 1 to supply boat 3, cuttings may be discharged through pipe 6 to a hose connection pipe 7. Supply boat 3 is fitted with a storage assembly 8, wherein storage assembly 8 may include a number of additional cuttings storage vessels 9, including, for example, pneumatic conveying vessels. Supply boat 3 may be brought

proximate to rig 1, and a flexible hose 10 extended therebetween. In this embodiment, flexible hose 10 connects storage assembly 8 to cuttings storage vessels 2 via connection pipe 7.

[0034] In one embodiment, as shown in Figure 2, two discrete streams of materials may be transferred contemporaneously (*i.e.*, at least partially during the same time interval) to a transport vehicle, for example, supply boat 3. In this embodiment, a first supply line 20 may transfer a first material from at least a first storage vessel 29 to supply boat 3 and a second supply line 22 may transfer a second material from at least a second storage vessel 28 to supply boat 3. The first and second materials may be transferred to a cuttings storage assembly 25 disposed on supply boat 3. Alternatively, the first and second materials may be transferred to a storage tank (not shown) disposed on or below the deck of supply boat 3.

[0035] In one embodiment, the first material may include dry cuttings, while the second material includes a fluid. One of ordinary skill in the art will appreciate that a fluid may include a liquid, a slurry, or a gelatinous material. Additionally, one of ordinary skill in the art will appreciate that dry cuttings may include cuttings processed by a separatory cleaning system or thermal treatment system, and as such, may include small amounts of residual fluids, hydrocarbons, and/or other chemical additives used during the cleaning process. Pumps (not shown) may be coupled to the storage vessels 28, 29 to facilitate the transfer of material, including, for example, dry cuttings, a fluid, or a slurry, from a separatory cleaning operation or thermal treatment system on the rig to supply boat 3. Alternatively, a pneumatic transfer system 26 may be coupled to the storage vessels 28, 29 to transfer materials, including dry cuttings, fluids, and slurries, to the supply boat 3. In one embodiment, the pneumatic transfer system 26 may include a forced flow pneumatic transfer system as disclosed in U.S. Patent Nos. 6,698,989, 6,702,539, and 6,709,216. Providing contemporaneous transfer of discrete material streams (*e.g.*, dry cuttings, fluids), may reduce the transportation time between a rig and a transport vehicle, such as, supply boat 3.

[0036] In one embodiment, cuttings storage assembly 25 may include at least one cuttings storage vessel 24. As such, the first material and the second material may be transferred to a single cuttings storage vessel 24 of cuttings storage assembly 25. In another embodiment, the first material and the second material may be transferred to

separate cuttings storage vessels 24 of cuttings storage assembly 25. In one embodiment, a cutting storage vessel 24 disposed on the supply boat 3 may be used in a slurrification system, as disclosed below with reference to cuttings storage vessels disposed on a rig. In this embodiment, briefly, a module (not shown) may be operatively connected to the cuttings storage assembly 25 to incorporate existing cuttings storage vessels 24 into a slurrification system.

[0037] Integration of a cuttings storage vessel into a slurrification system is now described with respect to a cuttings storage vessel disposed on a rig. One of ordinary skill in the art, however, will appreciate that the cuttings storage vessel may be disposed at any work site, including a rig, a transport vehicle, or other treatment facility, without departing from the scope of embodiments disclosed herein. In this embodiment a module may be disposed at the work site proximate the cuttings storage vessel and operatively connected to the cuttings storage vessel, thereby converting the cuttings storage vessel from a vessel for storing cuttings to a component of a slurrification system.

[0038] As described above, previous fluid slurrification systems required the conversion of valuable drilling rig space for storing independent fluid recovery vessels and processing equipment. However, embodiments disclosed herein allow existing structural elements (*i.e.*, cuttings storage vessels 202) to be used in multiple operations. Modules in accordance with embodiments disclosed herein are relatively small compared to previous systems, thereby preserving valuable drill space, and preventing the need for costly and dangerous lifting operations. Those of ordinary skill in the art will appreciate that the system as illustrated in Figures 1-3 and 5-6 are only exemplary, and alternate systems incorporating additional components, for example, fluid cleaning components or tank cleaning components, may also be used in combination with slurrification systems disclosed herein. Illustrative examples of such systems are described in greater detail below.

[0039] Referring now to Figure 3, a slurrification system 300 incorporating a first cuttings storage vessel 302 is illustrated. Slurrification system 300 includes a module 352, or drive unit, configured to operatively connect with the first cuttings storage vessel 302, and a fluid supply line 378. Module 352 may include a containment unit,

a skid, a housing, or a moveable platform configured to house select slurrification system components, as described in more detail below.

[0040] In this embodiment, system 300 includes an independent power source 360 for providing power to components of module 352. Power source 360 is electrically connected to, for example, grinding device 354 and/or a programmable logic controller (PLC) 361. Those of ordinary skill in the art will appreciate that such a power source may provide primary or auxiliary power for powering components of module 352. In other embodiments, power source 360 may be merely an electrical conduit for connecting a power source on a rig (not shown) via an electrical cable 362, to module 352.

[0041] Module 352 includes an inlet connection 370 configured to connect with outlet 372 of first cuttings storage vessel 302, and an outlet connection 374 configured to connect with an inlet 376 of first cuttings storage vessel 302. Inlet connection 370 may be connected to outlet 372 and outlet connection 374 may be connected to inlet 376 by fluid transfer lines, for example, flexible hoses and/or new or existing piping. Module 352 further includes a grinding device 354 configured to facilitate the transfer of fluids from the first cuttings storage vessel 302, through the module 352, and back to the first cuttings storage vessel 302. Grinding device 354 is configured to reduce the particle size of solid materials of the drill cuttings transferred therethrough.

[0042] In one embodiment, grinding device 354 may include a grinding pump. The grinding pump may be, for example, a centrifugal pump, as disclosed in U.S. Patent No. 5,129,469, and incorporated by reference herein. As shown in Figure 4, a centrifugal pump 458, configured to grind or reduce the particle size of drill cuttings, may have a generally cylindrical casing 480 with an interior impeller space 482 formed therein. Centrifugal pump 458 may include an impeller 484 with backward swept blades with an open face on both sides, that is, the blades or vanes 485 are swept backward with respect to a direction of rotation of the impeller and are not provided with opposed side plates forming a closed channel between the impeller fluid inlet area 487 and the blade tips. The casing 480 has a tangential discharge passage 488 formed by a casing portion 490. The concentric casing of centrifugal pump 458 and the configuration of the impeller blades 485 provide a shearing action that reduces the particle size of drill cuttings. The blades 485 of the impeller 484 may

be coated with a material, for example, tungsten carbide, to reduce wear of the blades 485. One of ordinary skill in the art will appreciate that any grinding pump known in the art for reducing the size of solids in a slurry may be used without departing from the scope of embodiments disclosed herein.

[0043] In an alternative embodiment, as shown in Figure 5, grinding device 554 may include a pump 556 and a grinder 557, for example, a ball mill. In this embodiment, cuttings may be injected into the grinder 557, wherein the particle size of the solids is reduced. The pump 556 may then pump the slurry back to first cuttings vessel 502. In one embodiment, the pump may include a grinding pump, as disclosed above, as a second grinder, for further reduction of the particle size of solids exiting the grinder 557.

[0044] Referring back to Figure 3, in one embodiment, slurrification system 300 further includes a second cuttings storage vessel 390. Second cuttings storage vessel 390 may be configured to supply cuttings to first cuttings storage vessel 302. In one embodiment, a pump (not shown), as known in the art, may be used to transfer the cuttings. In another embodiment, a pneumatic transfer device (not shown), as disclosed above, may be used to transfer the cuttings to the first cuttings storage vessel 302. One of ordinary skill in the art will appreciate that any method for transferring the cuttings to first storage vessel 302 may be used without departing from the scope of embodiments disclosed herein.

[0045] In one embodiment, module 352 may further include a pneumatic control device (not shown) to control the flowrate of air injected into the cuttings storage vessel 302 by a pneumatic transfer device (not shown). In such an embodiment, an air line (not shown) from an air compressor (not shown) may be coupled to the pneumatic control device (not shown) in module 352 to control a flow of air into first cuttings storage vessel 302.

[0046] In another embodiment, cuttings may be supplied to first cuttings storage vessel 302 from a classifying shaker (not shown) or other cuttings separation or cleaning systems disposed on the drilling rig. Additionally, multiple cuttings storage vessels may be connected to and supply cuttings to first cuttings storage vessel 302. In one embodiment, each cuttings storage vessel may be configured to supply cuttings of predetermined sizes, for example, coarse cuttings or fines. Cuttings of a selected

size may then be provided to first cuttings storage vessel 302 to form a slurry of a predetermined density. One of ordinary skill in the art will appreciate that the cuttings may be transferred to the first cuttings storage vessel 302 by any means known in the art, for example, by a pump or a pneumatic transfer device, as described above.

[0047] During operation of slurrification system 300, fluid supply line 378 may be configured to supply a fluid to first cuttings storage vessel 302. One of ordinary skill in the art will appreciate that the fluid supply line 378 may supply water, sea water, a brine solution, chemical additives, or other fluids known in the art for preparing a slurry of drill cuttings. As the fluid is pumped into first cuttings storage vessel 302, cuttings from the second cuttings storage vessel 390, or other components of the rig's cuttings separation system, as described above, may be transferred into first cuttings storage vessel 302.

[0048] As first cuttings storage vessel 302 fills with fluid and cuttings, the mixture of fluid and cuttings is transferred to module 352 through the inlet connection 370 of the module 352. In one embodiment, the mixture may be transferred by a pneumatic transfer device, a vacuum system, a pump, or any other means known in the art. In one embodiment, the pneumatic transfer device may include a forced flow pneumatic transfer system. The mixture of fluid and cuttings is pumped through grinding device 354, wherein the cuttings are reduced in size. The mixture, or slurry, is then pumped back to first cuttings storage vessel 302 via outlet connection 374. The slurry may cycle back through module 352 one or more times as needed to produce a slurry of a predetermined density or concentration of cuttings as required for the particular application or re-injection formation.

[0049] Referring now to Figure 6, in one embodiment, module 652 further includes a valve 694 disposed downstream of grinding device 654, wherein valve 694 is configured to redirect the flow of the slurry exiting the grinding device 654. In one embodiment, a PLC 661 may be operatively coupled to module 652 and configured to close or open the valve 694, thereby redirecting the flow of the slurry. In one embodiment, the PLC 695 may control the valve 694 to move after a pre-determined amount of time of fluid transfer through module 652. In another embodiment, a sensor (not shown) may be operatively coupled to the valve 694 to open or close the

valve when a pre-determined condition of the slurry is met. For example, in one embodiment, a density sensor (not shown) may be coupled to valve 694, such that, when the density of the slurry exiting grinding device 654 reaches a pre-determined value, valve 694 moves, *i.e.*, opens or closes, and redirects the flow of the slurry from the first cuttings storage vessel 302 to another cuttings storage vessel, a slurry tank, a skip, or injection pump for injection into a formation.

[0050] In another embodiment, a conductivity sensor (not shown) may be coupled to valve 694, such that, when the density of the slurry exiting grinding device 654 reaches a pre-determined value, valve 694 moves and redirects the flow of the slurry from the first cuttings storage vessel 302 to another cuttings storage vessel, a slurry tank, a skip, or injection pump for injection into a formation. One of ordinary skill in the art will appreciate that other apparatus and methods may be used to redirect the flow of the slurry once a predetermined concentration of cuttings in suspension, density, or conductivity has been met. Commonly, a slurry with a concentration of up to 20% cuttings in suspension is used for re-injection into a formation. However, those of ordinary skill in the art will appreciate that direct injection of slurry, using embodiments of the present disclosure, may provide for increases in concentration of cuttings in the slurry.

[0051] A slurry formed by a slurrification system, as described above, may be transferred to another cuttings storage vessel, a slurry tank, a skip, or directly injected into a formation. Slurry that is transferred to a tank, vessel, skip, or other storage device, may be transferred off-site to another work site. In one embodiment, the storage device may be lifted off of a rig by a crane and transferred to a boat. Alternatively, slurry may be transferred from the storage device to a slurry tank disposed on the boat.

[0052] In one embodiment, the slurry may be transported from one work site to another work site for re-injection. For example, the slurry may be transported from an offshore rig to another offshore rig. Additionally, the slurry may be transported from an offshore rig to an on-land work site. Further the slurry may be transported from an on-land work site to an offshore work site.

[0053] Those of ordinary skill in the art will appreciate that components of systems 300, 500, and 600 may be interchanged, interconnected, and otherwise assembled in a

slurrification system. As such, to address the specific requirements of a drilling operation, in particular, for cuttings re-injection, the components of the systems and modules disclosed herein may provide for an interchangeable and adaptable system for slurrification at a drilling location.

[0054] Advantageously, embodiments disclosed herein may provide a slurrification system that reduces the amount of required space at a work site to operate the slurrification system. In another aspect, embodiments disclosed herein may provide a slurrification system that reduces the amount of equipment or number of components required to prepare a slurry for re-injection into a formation. In yet another aspect, embodiments disclosed herein may provide a safer slurrification system by reducing the number of crane lifts required to install the system.

[0055] Furthermore, embodiments disclosed herein advantageously provide a module configured to connect to a cuttings storage vessel on a drilling work site, thereby converting a cuttings storage vessel into a component of a slurrification system. As such, modules of the present disclosure may allow for existing infrastructure on an offshore platform to perform multiple functions, such as, allowing cuttings storage vessels to be used in both the storage and transfer of cuttings, as well as, being used in a slurrification system.

[0056] While the invention has been described with respect to a limited number of embodiments, those skilled in the art, having benefit of this disclosure, will appreciate that other embodiments may be devised which do not depart from the scope of the invention as disclosed herein. Accordingly, the scope of the invention should be limited only by the attached claims.

CLAIMS

What is claimed:

1. A system for preparing slurry on a rig, the system comprising:
a first cuttings storage vessel;
a module comprising:
 a grinding device configured to facilitate the transfer of fluids,
 an inlet connection configured to connect to an outlet of the first cuttings storage vessel, and
 an outlet connection configured to connect to an inlet of the first cuttings storage vessel; and
a fluid supply line in fluid communication with the first cuttings storage vessel.
2. The system of claim 1, wherein the grinding device comprises a pump and a grinder.
3. The system of claim 1, wherein the grinding device comprises a grinding pump.
4. The system of claim 1, further comprising a second cuttings storage vessel configured to supply cuttings to the first cuttings storage vessel.
5. The system of claim 4, further comprising a pneumatic transfer device configured to facilitate the transfer of cuttings from the second cuttings storage vessel to the first cuttings storage vessel.
6. A module comprising:
a grinding device configured to facilitate the transfer of fluids;
an inlet connection configured to connect to an outlet of a first cuttings storage vessel disposed on a rig; and
an outlet connection configured to connect to an inlet of the first cuttings storage vessel.
7. The module of claim 6, wherein the grinding device comprises a pump and a grinder.
8. The module of claim 6, wherein the grinding device comprises a grinding pump.

9. The module of claim 6, further comprising a programmable logic controller operatively coupled to the module.
10. A method of operating a slurrification system comprising:
 - using a first vessel for cuttings storage; and
 - operating the first vessel in a slurrification process.
11. The method of claim 10, further comprising using the first vessel for cuttings transport.
12. The method of claim 10, wherein the operating the first vessel in a slurrification process comprises:
 - connecting a module to the first vessel, the module comprising:
 - a grinding device configured to facilitate the transfer of fluids;
 - an inlet connection configured to connect to an outlet of the first vessel; and
 - an outlet connection configured to connect to an inlet of the first vessel.
13. The method of claim 12, further comprising providing a fluid to the first vessel.
14. The method of claim 13, further comprising transferring cuttings from a second vessel into the first vessel.
15. The method of claim 12, further comprising pumping a mixture of fluids and cuttings from the first vessel through the grinding device via the inlet connection of the module, and returning the mixture to the first vessel via the outlet connection.
16. A method of converting a first cuttings storage vessel for use in a slurrification system, comprising:
 - connecting the module of claim 6 to at least the first cuttings storage vessel.
17. The method of claim 16, wherein the connecting the module comprises:
 - connecting a power supply of the module to a power source; and
 - connecting at least one fluid transfer line from the module to the first cuttings storage vessel.
18. A method of transferring material from a work site to a transport vehicle, the method comprising:

transferring a first material from a first cuttings storage vessel disposed at the work-site to a cuttings storage assembly disposed on the transport vehicle; and transferring a second material from a second cuttings storage vessel disposed at the work site to the cuttings storage assembly disposed on the transport vehicle, wherein the transferring of the first material and the transferring of the second material occurs contemporaneously, and wherein the first material comprises dry cuttings and the second material comprises a fluid.

19. The method of claim 18, wherein the cuttings storage assembly comprises at least one cuttings storage vessel.
20. The method of claim 19, wherein the first material and the second material are transferred to a single cuttings storage vessel of the cuttings storage assembly.
21. The method of claim 18, further comprising slurrifying the first material and the second material in the cuttings storage assembly.
22. The method of claim 21, wherein the slurrifying comprises operatively connecting the module of claim 6 to the cuttings storage assembly.
23. The method of claim 18, wherein the second material comprises a slurry.

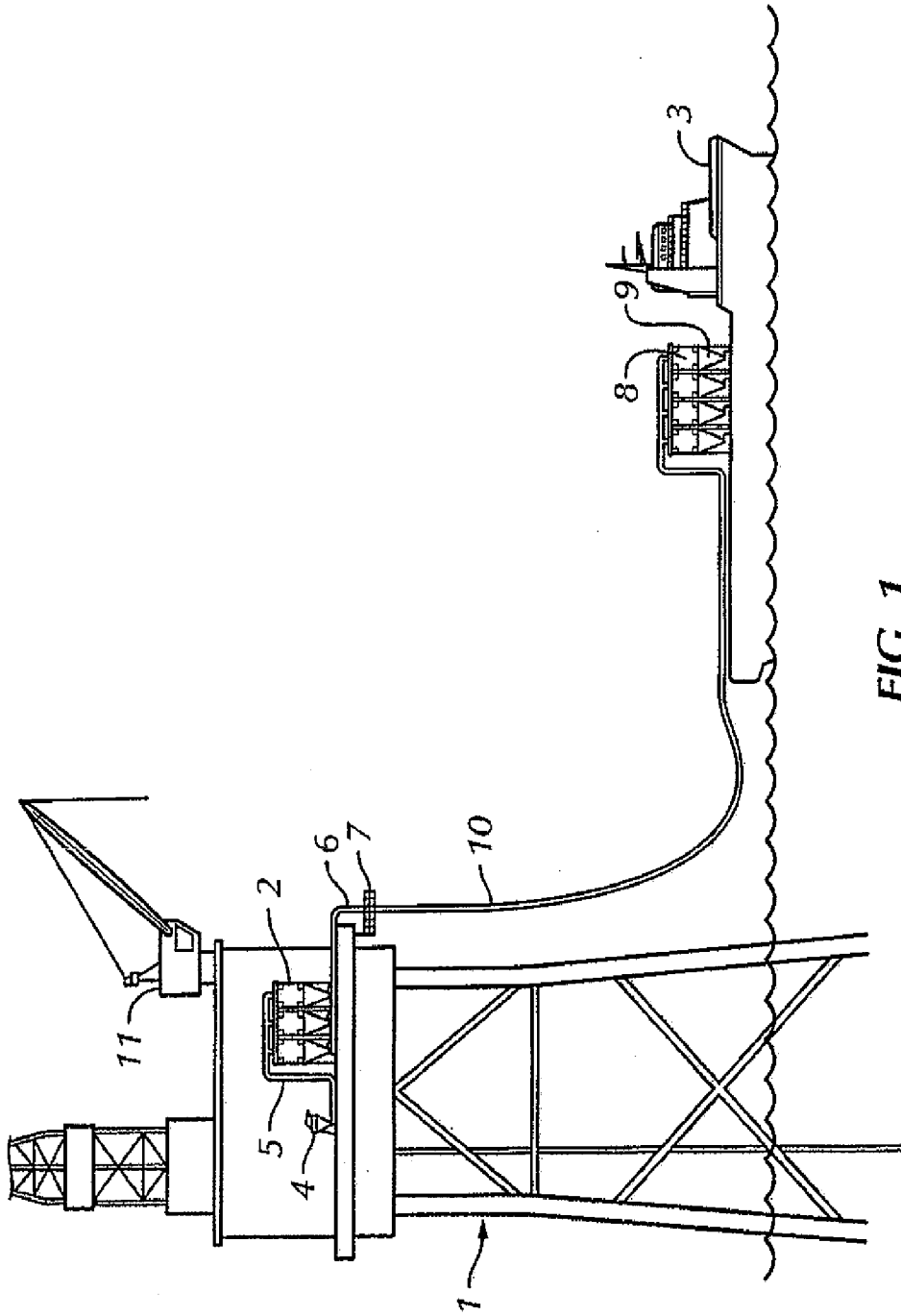

FIG. 1

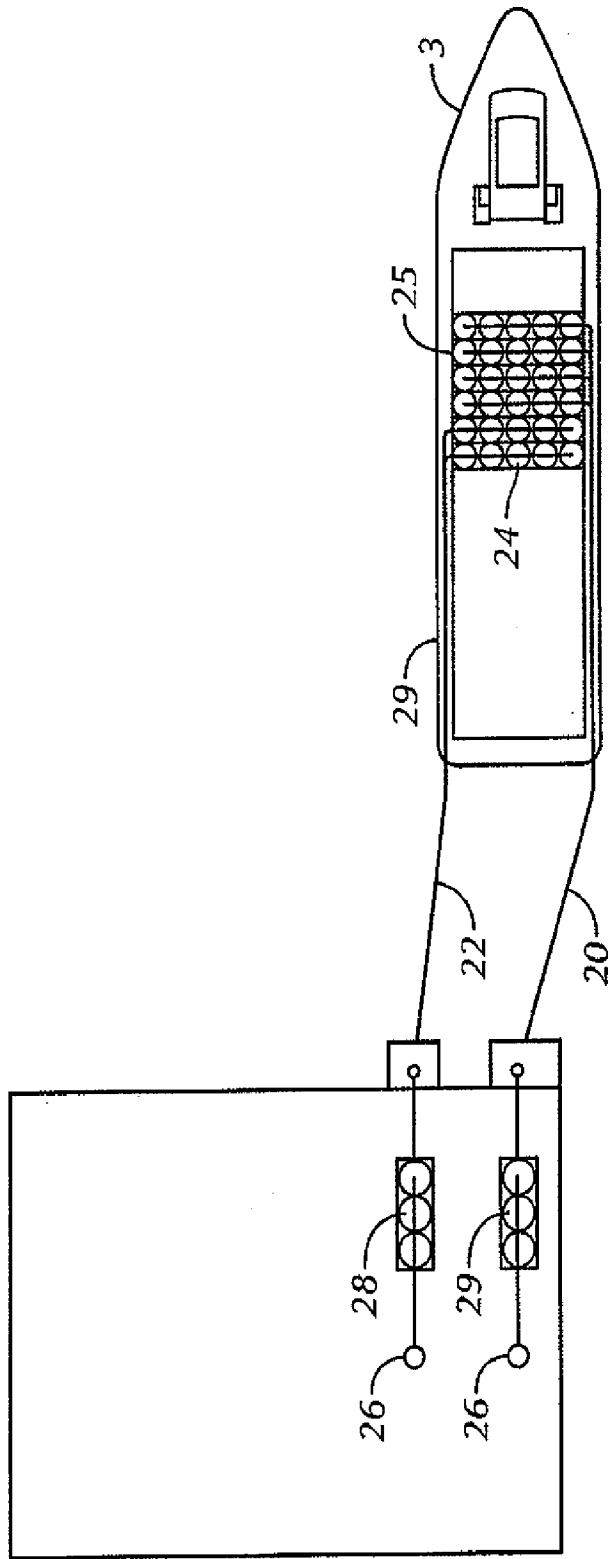

FIG. 2

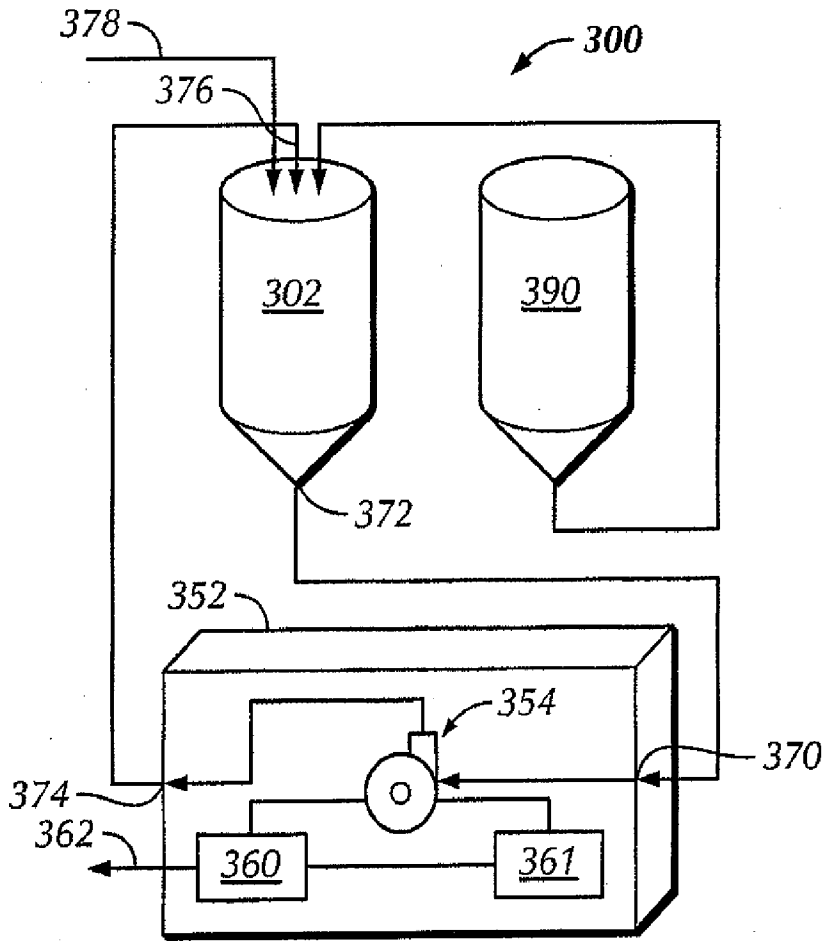

FIG. 3

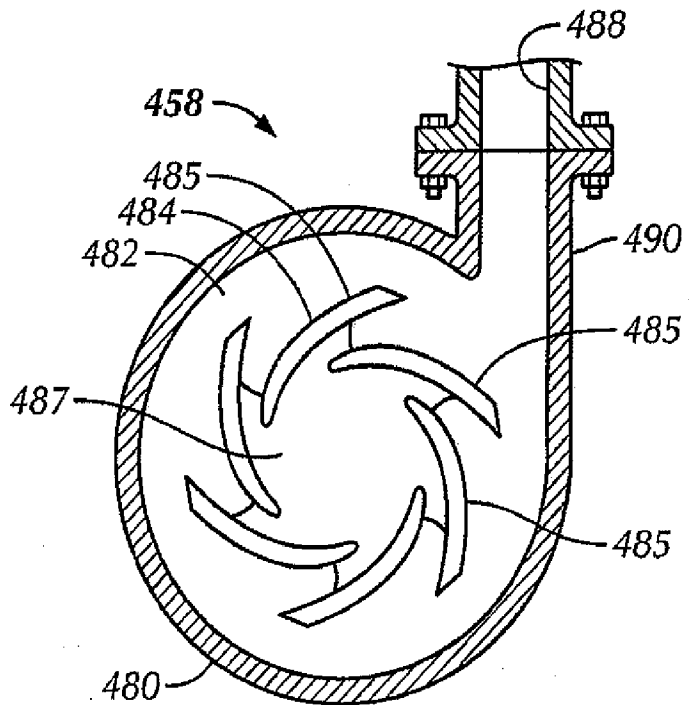

FIG. 4

