



(72) HIMES, RICKY A., US

(71) ATOTECH USA, INC., US

(51) Int.Cl.⁶ B05D 7/00

(30) 1997/01/21 (08/786,029) US

(54) **APPAREIL ET PROCÉDE DE DISTRIBUTION DE FLUIDE**

(54) **FLUID DELIVERY APPARATUS AND METHOD**

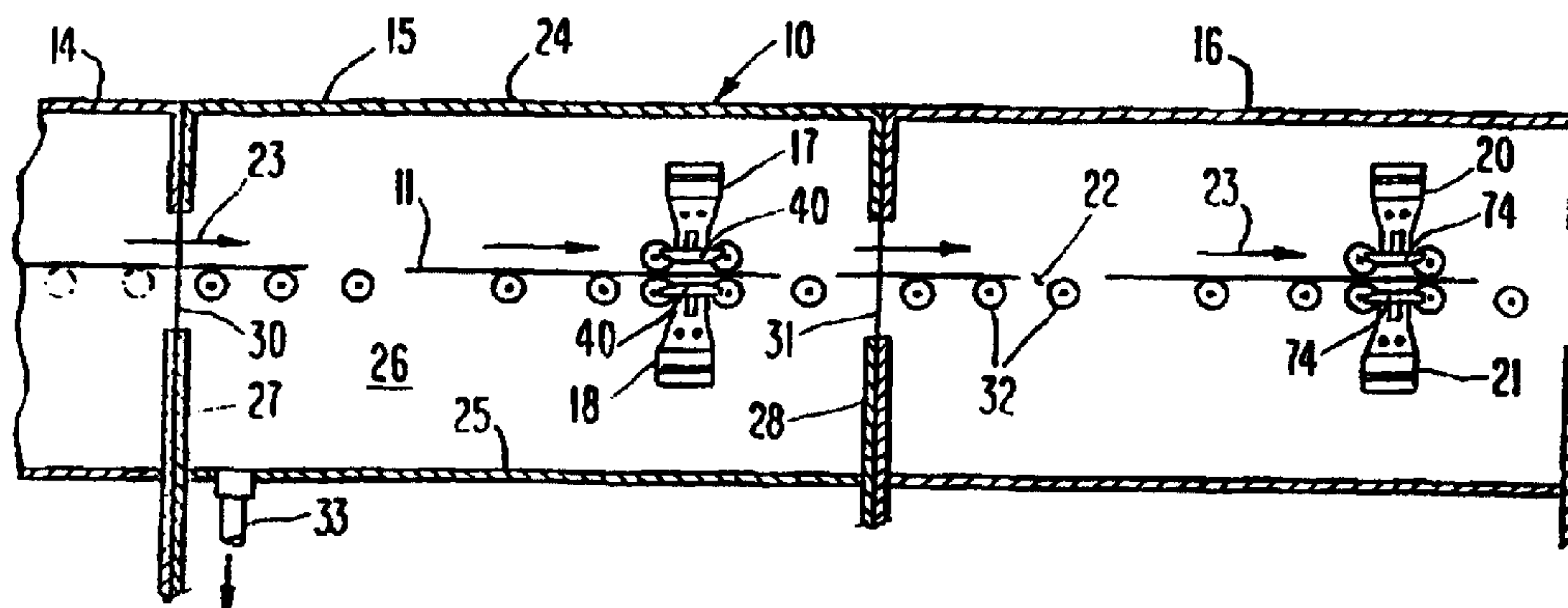

(57) Cette invention se rapporte à un appareil distributeur de fluide (10) et à un procédé correspondant, dans lesquels un liquide ou un fluide gazeux est fourni par les distributeurs de fluide (17, 18), via des plaques à ajutages (40) associées audit distributeur, sur chaque côté d'une trajectoire d'avance d'articles (11) traités par ledit fluide, les ouvertures des ajutages des plaques à ajutages coopérant avec une ou plusieurs rainures transversales (67), afin de former un flux de fluide faisant écran, qui s'étend transversalement à la trajectoire d'avance (22) des articles et qui est dirigé en direction desdits articles. Au cas où le fluide est un liquide, les ouvertures des ajutages forment des colonnes de liquide en forme de filaments cylindriques, qui sont transformées par les rainures associées en un jet pulvérisé de liquide, plat et disposé transversalement, faisant écran. Dans les cas où le fluide est un gaz, les ouvertures des ajutages et des rainures transversales coopèrent pour distribuer le gaz dans des zones planes transversales, transversalement espacées, formées par du gaz dirigé vers la trajectoire d'avance des articles.

(57) A fluid delivery apparatus (10) and method is provided wherein either liquid or gaseous fluid is provided from fluid dispensers (17, 18), via nozzle plates (40) associated therewith, on each side of a path of travel of articles (11) being treated by the fluid, and wherein nozzle openings in nozzle plates cooperate with transverse groove(s) (67) to provide a screen flow of fluid extending transversely of the path of travel (22) of articles, and directed toward the articles. In the case of the fluid being a liquid, the nozzle openings provide cylindrical filament-like columns of liquid which are rendered by the associated grooves into flat, transversely disposed screen spray of liquid. In the case of the fluid being a gas, the nozzle openings and transverse grooves cooperate to deliver the gas in transversely spaced apart, transverse, planar zones of gas directed toward the path of article travel.

PCT

WORLD INTELLECTUAL PROPERTY ORGANIZATION
International Bureau

INTERNATIONAL APPLICATION PUBLISHED UNDER THE PATENT COOPERATION TREATY (PCT)

(51) International Patent Classification ⁶ : B05D 7/00	A1	(11) International Publication Number: WO 98/31475 (43) International Publication Date: 23 July 1998 (23.07.98)
<p>(21) International Application Number: PCT/US97/21433</p> <p>(22) International Filing Date: 25 November 1997 (25.11.97)</p> <p>(30) Priority Data: 08/786,029 21 January 1997 (21.01.97) US</p> <p>(71) Applicant: ATOTECH USA, INC. [US/US]; 500 Science Park Road, State College, PA 16803-2299 (US).</p> <p>(72) Inventor: HIMES, Ricky, A.; 235 Bush Road, Boalsburg, PA 16872 (US).</p> <p>(74) Agents: McNULTY, John, F. et al.; Paul & Paul, 2900 Two Thousand Market Street, Philadelphia, PA 19103 (US).</p>	<p>(81) Designated States: CA, JP, European patent (AT, BE, CH, DE, DK, ES, FI, FR, GB, GR, IE, IT, LU, MC, NL, PT, SE).</p> <p>Published <i>With international search report.</i> <i>With amended claims.</i></p>	

(54) Title: FLUID DELIVERY APPARATUS AND METHOD

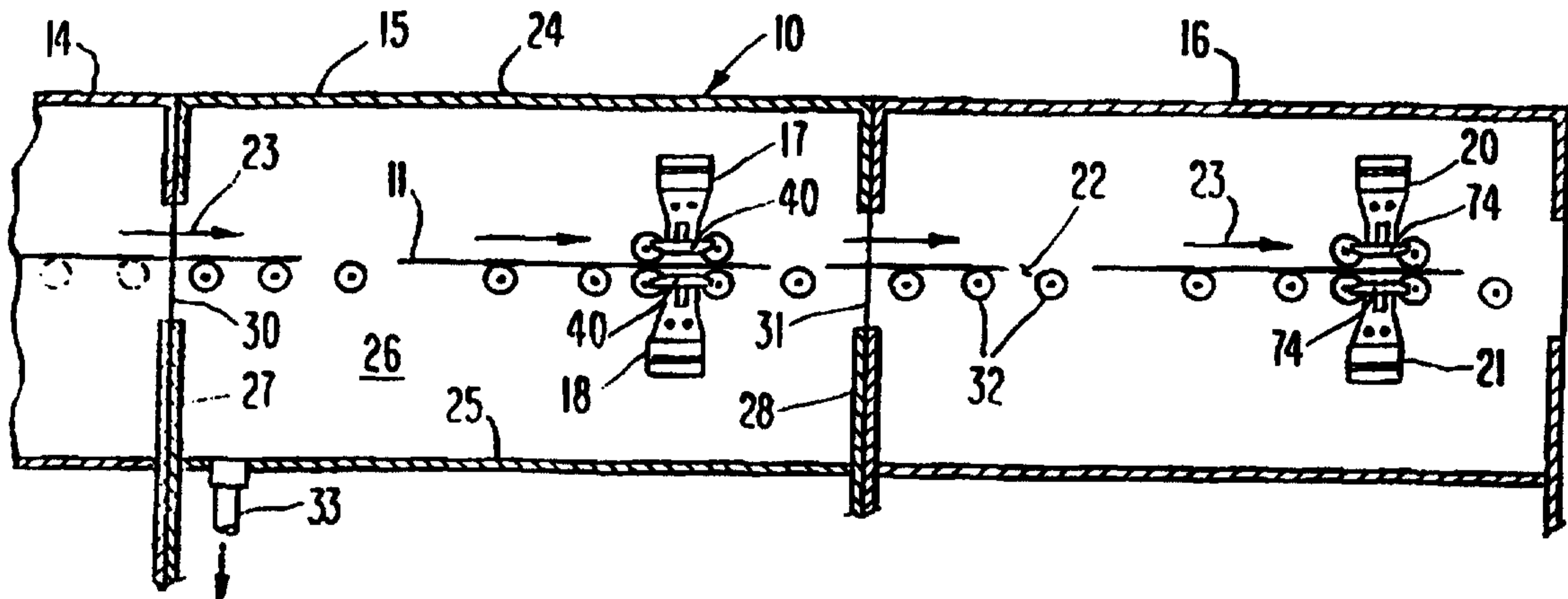

(57) Abstract

A fluid delivery apparatus (10) and method is provided wherein either liquid or gaseous fluid is provided from fluid dispensers (17, 18), via nozzle plates (40) associated therewith, on each side of a path of travel of articles (11) being treated by the fluid, and wherein nozzle openings in nozzle plates cooperate with transverse groove(s) (67) to provide a screen flow of fluid extending transversely of the path of travel (22) of articles, and directed toward the articles. In the case of the fluid being a liquid, the nozzle openings provide cylindrical filament-like columns of liquid which are rendered by the associated grooves into flat, transversely disposed screen spray of liquid. In the case of the fluid being a gas, the nozzle openings and transverse grooves cooperate to deliver the gas in transversely spaced apart, transverse, planar zones of gas directed toward the path of article travel.

-1-

Fluid Delivery Apparatus and Method

Cross-Reference to Related Applications

This a continuation-in-part of application Serial No. 08/514,313 filed August 11, 1995, now U.S. Patent 5,614,264.

5 Background of the Invention

In various wet processing arts involving chemical treatment, such as etching, electroplating and the like, it is known to deliver fluids onto surfaces of articles being treated. In many instances, the articles being treated are printed circuit boards and the like. Often such articles are being delivered along a
10 generally horizontal path and are etched, cleaned, rinsed, activated, dried, etc., at various stations along the path. Sometime the articles being treated, if they are printed circuit board, have bore holes extending therethrough and it is desired to have the treatment fluid impinge not only on upper and lower surfaces of the boards, but also on bore holes. The treatment of the articles can take place via
15 nozzle arrangements, such as that set forth in U.S. Patent 4,789,405, for example. In other instances the treatments may take the form of various other fluid delivery, spraying, drying techniques, such as those disclosed in U.S. Patents 4,576,685, 4,017,982, 3,935,041, 3,905,827, or 3,776,800. Various drive techniques for driving the printed circuit boards or other articles through the various treatment
20 stations may be used, such as those set forth in U.S. 4,046,248 or the like.

Accordingly, the technical field of this invention is directed to a method and arrangement for treating conductor substrates. Such treatment processes can include the removal of liquid from through-holes in conductors boards and from its surface, drying the boards, in addition to cleaning, coating, rinsing, etching,
25 activation and various electrolytic processes.

The present invention is directed toward efficient delivery of fluid to articles being treated, and most particularly to conductor boards and the like.

In connection with the fluid delivery, slotted tubes, for example have been used, but such are limited in development of the flow upon exiting the orifice or
30 slot, such that the flow stream may dissipate more quickly and lose some of its

-2-

momentum, even orientally, as the distance from the substrate being treated increases.

Spray nozzles are also use, but such often require large amounts of energy relative to the fluid medium being processed. Additionally, in some instances
5 spray nozzles do not provide the desired level of uniformity in terms of coverage, with a higher percentage of flow and pressure being located at the center of the nozzle spray pattern, and a lesser percentage of flow and pressure outwardly thereof, in that flow and pressure are often substantially reduced as the distance is increased perpendicular to the centerline of the nozzle.

10 Fluid jet injectors have also been used to produce tight columns of flow, but also generally fail to provide a desired level of uniform and complete coverage of the article being treated. Additionally, small injectors require substantially higher pressure to maintain a desired impact of force on the article being treated, which high force impact may not always be desirable.

15 **Summary of the Invention**

The present invention provides a method and apparatus for delivering a fluid to printed circuit boards or other articles being treated, as the articles are delivered along a path of travel, by impinging the fluid on the articles from both sides of their path of travel. During such travel fluid is dispensed from nozzles
20 and directed via the nozzles themselves and grooves that connect the nozzles, such that the fluid is provided in the form of a transverse extended screen-like fluid flow from the nozzle openings. The fluid delivered may be either liquid or gas. In the case of a liquid, the nozzle openings disseminate the flow into cylindrical filament-like columns of liquid flow, connected via the grooves into a generally flat
25 transversely disposed, planar screen spray of liquid. In the case of a gas fluid, such is provided via nozzle openings and transverse grooves connecting rows of openings, which openings are transversely spaced apart to facilitate disseminating from the openings via the grooves separate, spaced-apart, transversely aligned planar zones of gas flow directed toward the path of article travel. Optionally, a

-3-

suction effect may be created by an upstream-converging surface of the nozzle.

Various adjustments are provided for the apparatus in accordance with this invention. Additionally, various preferred parameters and structural arrangements are utilized. In some cases a row of nozzle openings is directed at an angle to the path of travel, aimed at the upstream direction of the path of travel.

Accordingly, it is a primary object of this invention to provide a novel method and apparatus for imparting fluid delivery to an article being conveyed along a predetermined path.

It is a further object of this invention to accomplish above object, wherein the fluid delivery is gas for drying an article, such as a conductor board.

It is another object of this invention to accomplish the primary object wherein the fluid delivery is a liquid fluid delivery, such as for rinsing, etching, etc.

It is another object of this invention to accomplish the above objects, wherein a readily removable nozzle section that contains the fluid discharge or orifices is provided, for ready cleaning or the like of that nozzle section.

It is a further object of this invention to accomplish the above objects, wherein variations are provided between transverse center lines of nozzles in a row and center lines of transverse grooves that connect the nozzles.

It is another object of this invention to accomplish the above objects, wherein the transverse grooves that connect the orifices of nozzles may be at acute angles to the longitudinal path of flow of articles being treated.

Other objects and advantages will be readily understood upon a reading of the following brief description of the drawings, detailed description of the preferred embodiments and the appended claims.

Brief Description of the Drawing Figures

Fig. 1 is a longitudinal sectional, schematic view, taken through a multi-station apparatus in accordance with this invention, wherein a plurality of etching, rinsing, drying, operations are illustrated, and wherein means for imparting fluid

-4-

delivery above and below articles such as circuit conductors, are illustrated.

Fig. 2 is a schematic, perspective view of a circuit board conductor being delivered along its path between upper and lower fluid dispenser manifolds in accordance with this invention, with the manifolds being of a type illustrated above and below the path of travel in Fig. 1.

Fig. 3 is an enlarged view of upper and lower fluid delivery manifolds as shown in Fig. 1, with delivery plates thereof being shown in full lines close to the path of article travel, and in phantom lines spaced more so from the path of articles travel.

Fig. 4 is a view taken generally along the line of IV-IV of Fig. 3, showing the lower end of a nozzle plate surface of an upper manifold, fragmentally illustrated.

Fig. 5 is a longitudinal section taken generally along the line V-V of Fig. 4, wherein two generally perpendicularly disposed nozzles are illustrated, with an angled nozzle being illustrated, disposed therebetween.

Fig. 5A is an enlarged detailed view of one of the nozzles and its associated groove illustrated in Fig. 5, wherein the geometric arrangement thereof is more clearly shown.

Fig. 6 is a view similar to that of the liquid dispensing nozzle plate of Fig. 4, but with the nozzle plate of Fig. 6 being specifically adapted for gas dispensing, such as drying air or the like.

Fig. 7 is a longitudinal sectional view similar to that of Fig. 5 but taken generally along the line of VII-VII of Fig. 6.

Fig. 8 is an enlarged fragmentary longitudinal sectional view taken through an alternative gas delivery pair of manifolds disposed on opposite sides of a path of travel of articles being treated, wherein the surfaces of the manifold plates closest to the path of travel are converging in an upstream direction to facilitate suction of fluid conveyed for impinging surfaces of articles being treated.

Fig. 9 is a fragmentary longitudinal, sectional view, taken through a nozzle plate in accordance with this invention, wherein a separate nozzle plate base

-5-

section and nozzle plate removable section are illustrated, with seals along transverse dovetail joints.

Fig. 10 is an enlarged, fragmentary, vertical sectional view, taken generally along the line X-X of Fig. 9, and wherein an end plate is illustrated, sealingly
5 connecting the nozzle base section and nozzle removable section.

Fig. 11 is an enlarged, fragmentary vertical, longitudinal sectional view taken through a nozzle orifice and groove in accordance with this invention.

Fig. 12 is view similar to that of Fig. 11, but wherein a cylindrical column of fluid (preferably liquid) being discharged from the nozzle is diagrammatically
10 illustrated.

Fig. 13 is a view similar to that of Fig. 12, but wherein the diagrammatically illustrated column of fluid is at an acute angle to the path of article flow (or generally horizontal surface of the nozzle plate), and wherein the transverse groove is at a center line different from that of the center line
15 connecting nozzle orifices transverse of the nozzle plate.

Detailed Descriptions of the Preferred Embodiments

Referring now to the drawings now in detail, reference is first made to Fig. 1, in which a fluid treatment system for articles being conveyed is generally designated by the numeral 10. In this embodiment, the articles being conveyed are
20 printed circuit boards or the like 11, with through-holes such as 12 extending there through, with connecting portions 13 functioning as conductors along portions of the boards, as shown in Fig. 2.

In Fig. 1, a plurality of stations 14, 15 and 16 are illustrated, with station 14 functioning perhaps as an etching chamber wherein a suitable etchant may be
25 dispensed onto appropriate surfaces of a printed circuit board or the like, followed perhaps by a rinsing station 15, in which the etchant liquid (or other treatment fluid) would be rinsed from the articles 11 by means of fluid dispensers 17,18, followed by passage of the articles into another station 16, which may for example be a gas treatment station such as an air drying station wherein air is dispensed via

-6-

dispensers 20,21 which, like the dispensers 17,18, are disposed on opposite sides of a path of travel 22 for articles being conveyed through the apparatus of the system 10, as shown, from left to right, in the direction of the arrows 23.

Each of the stations 14-16 are provided with upper and lower walls, 24,25, side walls 26, inlet and outlet walls 27,28 with appropriate inlet and outlet openings 30,31, respectively.

The path 22 of travel of the articles 11 is therefore a longitudinal path of travel through the machine and in the embodiment shown, the path 22 is generally horizontal.

Appropriate drive rollers 32 are provided, generally shaft-mounted on transversely disposed shafts, which in turn are driven by any suitable means, such as a drive means for example as shown in U.S. Patent 4,015,706.

In instances particularly where the treatment fluid in a given station is liquid, such as for the station 15, an appropriate liquid discharge line 33 may be provided, for discharge for recycling or the like, as desired.

With reference to Fig. 2, in particular, the article 11 is shown being delivered substantially horizontally in the direction of arrow 23, beneath a dispenser 17 and above a dispenser 18, it being understood that Fig. 2 could equally well represent dispensers 20,21 as desired.

With reference to Fig. 3, it will be seen that the upper dispenser 17 is disposed above the lower dispenser 18 for conveyance of articles 11 therebetween in a longitudinal, generally horizontal path of travel, as shown.

The dispenser 17 includes a manifold 35 which receives treatment liquid via a inlet tube 36 or the like, for delivery down through the manifold 35, through a manifold transition plate 37 having a large number of spaced apart transition holes 38 therein, arranged in a row, which extends transversely, substantially between sidewalls 26 of the apparatus as shown in dotted lines in Fig. 3. The fluid thus delivered via conduit 36 and manifold transition holes 38 is thus delivered to a multi-port fluid dispenser nozzle plate 40. The nozzle plate has a plurality of fluid dispenser nozzle openings 41, 42 and 43, arranged in transverse rows,

-7-

perpendicular to the longitudinal path of travel 22 for articles 11, and extending generally the transverse length of the manifold 17, substantially completely between opposed sidewalls 26 of the apparatus.

5 A pair of article-engaging rollers 44,45 are provided, carried indirectly (by means not shown) by the manifold 17, respectively shaft-mounted at 46,47, to engage against an upper surface 48 of an article 11 being treated. The purpose of the upper and lower rollers 44,45 is to resist the forces of impingement of fluid being delivered to an article 11 being treated via a manifold on the opposite side of the path of travel 22. Thus, fluid delivered via lower dispenser 18 would impart
10 an upward component of motion to the article 11 being treated as shown in Fig. 3, but for the resistance applied by the rollers 44,45 in engagement with an upper surface 48 of the article 11. Conversely, fluid delivered from upper dispenser 17 onto an upper surface 48 of the article 11, would be resisted by the presence of lower rollers (unnumbered) carried by the dispenser 18.

15 In order to accommodate different thicknesses of article 11, the dispensers 17,18, are vertically adjustable by any suitable means, such that their dispenser nozzle plates 40 may move, for example, between the full line positions therefor shown in Fig. 3, to the phantom line positions shown therefor, for accommodating, for example, a thicker article 11, while still maintaining a desired predetermined
20 small spacing between the surface of the plate 40 (for example the lower surface thereof as shown in Fig. 3) and the adjacent surface of the article 11 (for example, the upper surface 48 as shown in Fig. 3).

The means for adjusting the positions of the dispensers 17,18 toward and away from the path 22 of article travel can be any suitable means. A
25 representative means is shown whereby an adjustable positionable member 50 is threadedly mounted through a fixed plate member 51, to support transversely extending posts 52 at opposite transverse ends of the dispenser 17, whereby turning the threaded member 50 may move the dispenser 17 from the full line position shown for the post 52 in Fig. 3, to the phantom line position shown therefor also
30 in Fig. 3, for movement of the plate 40 between the full line and phantom

-8-

positions described above. It will be understood that any suitable adjustment means may be provided for changing the relative positions of the dispensers.

In the case where the path of travel 22 is a substantially horizontal path as shown, and wherein the rollers 44,45 for the upper manifold engage an upper
5 surface 48 of articles 11 being treated, the weight of the rollers 44,45 may be used to provide the hold-down of the article 11 being treated in resisting upwardly directed flow from the dispenser 18. In such an instance, the shafts, 46,47 for the rollers 44,45, respectively, may be mounted in vertical slotted holes 53,54, as shown.

10 Also, it will be noted, with reference to Fig. 4 that a plurality of spaced apart notches 55, spaced generally along the plates 40 between sidewalls 26, may accommodate rollers, 44,45, passing therethrough, as shown in Fig. 3, with clearance, so as not to engage portions of the plate 40 defined by the notches 55. Such allows close placement of the rollers 44,45 to the openings 41, 42 and 43 and
15 similar openings on the opposite (lower) side of the path of travel 22 in the nozzle plate of the dispenser 18.

It will be apparent from Fig. 3 that the construction, operation, adjustment, etc. of the dispenser 18 is substantially the same as that of 17, so the description thereof will not be duplicated herein. However, with the operation of the
20 dispensers above and below the path 22 of article travel, it would generally not be necessary to provide slotted holes such as those 53 and 54 for facilitating (upward or downward) vertical movement of the posts that mount the lower rollers therein; that the phenomena described above with respect to the upper rollers 44,45 and their ability to move upward in slotted holes 53,54, is a function of utilizing
25 gravity to assure contact of the upper rollers on the upper surface 48 of the article 11.

It will also be apparent that, except for the details of discharge of fluid through the nozzle plates, the dispensers 20,21 will generally be constructed similar to and mounted similarly to, the dispensers 17 and 18 such that the
30 description provided above for the dispenser 17 applies equally well here too.

-9-

With reference to the illustration for the nozzle plate 40 illustrated in Fig. 4, it will be seen that the plate 40 while being shown fragmentally cut-off at the lower end thereof, actually extends substantially completely between sidewalls 26 of the apparatus.

5 The plate 40 is shown to have upper and lower surfaces 55,56, with chamfered upstream and downstream lower surface portions 57 and 58, respectively. The chamfered surface portion 57 facilitates article inlet between a pair opposing plates 40, and the chamfered surface 58 facilitates air inlet into the partial vacuum created by an eduction effect caused by the forward or upstream
10 directed flow from angled nozzles 60 located in rows between straight nozzles 61, 62 as will be discussed in more detail hereinafter. Such eduction of air would be in the direction indicated by the arrow 63 in Fig. 5 to fill the partial vacuum created by liquid being discharged via angled nozzles 60, and to facilitate the flow of liquid 60 across the upper surface of a printed circuit board or other article
15 being conveyed from an upstream direction to a downstream direction, pursuant to arrow 64 in Fig. 5.

The nozzles 61, it will seen, are arranged in a row extending transversely of the longitudinal path of travel, and are oriented generally perpendicular to the longitudinal path of travel 22. Each nozzle 61 in the row is comprised of a larger
20 diameter cylindrical blind hole zone 65 at the upper end, which joins a cylindrical tapered zone 66, therebeneath, which in turn communicates with a transverse groove 67. The transverse groove runs completely along the lower surface 56 of the plate 40, connecting the nozzle openings of nozzle zone 66, as shown in Fig. 4. The cylindrical taper "a" of zone 66 is in the range of 100° to 160° across its
25 diameter, and most preferably is approximately 120°. The transverse groove 67 has an included angle "b" as shown in Fig. 5A, within the range of 30° to 90°, and most preferably is approximately 60°.

The pressure applied to the liquid being disseminated via nozzle 61 and the spacing apart of the nozzles 61 are selected to develop the flow of liquid emanating
30 from the group of nozzles 61 in the transverse row shown, to produce from the

-10-

nozzles 61 a generally cylindrical filament-like column 68 of liquid, with the groove 67 connecting a plurality of small columns of liquid into a generally flat, transversely disposed, planar screen spray of liquid, such that the groove 67 facilitates a fan spray of liquid from the individual nozzles 61 into a screen as described.

Preferably, in addition to the row of nozzles 61, there is an identical, or substantially identical row of nozzles 62 disposed downstream thereof, also downstream of angled nozzles 60 as will hereinafter be described. Each nozzle 60 is generally similar to the nozzle 61 having a blind bore like that 65 for the nozzle 61, which meets a cylindrical taper at the lower end thereof, which in turn meets a connecting groove 70, connecting a plurality of nozzles 60, except that the connecting groove 70 and the several zones of the nozzles 60 are angled for liquid discharge in an upstream direction, at an angle "c" to the horizontal as shown in Fig. 5, which angle is preferably about 75°. It will be noted that it is the upstream directed spray via nozzles 60 that create the partial vacuum for flow of air in the direction of 63, for facilitating dissemination of liquid from the nozzles 60, 61 and 62 in an upstream direction or against the direction of flow of articles along their path.

With reference now to Fig. 6 and 7, the multi-port gas dispenser nozzle plates associated with the gas dispensing (generally air) station 16 are shown. Aside from the nozzle plates 74, the rest of the dispensers of 20,21 will generally be constructed along the lines of those 17,18, as aforesaid. Each nozzle plate 74, has a plurality of notches 75 which function as aforesaid for the notches 55 of the plate of Fig. 4. Additionally, each plate 74 likewise extends transversely of the apparatus between sidewalls 26, and has upper and lower surfaces 76,77, and lower chamfered upstream and downstream surface portions 78,80, pursuant to the embodiment discussed above.

However, the plate 74 is provided with a plurality of slotted holes 81 arranged in a transverse row along the plate 74, as shown. The slotted holes are separated by a plurality of transverse spacings 82. The slotted holes 81 are

-11-

connected by a transverse groove 83 in the lower surface 77 of the plate 74. The groove 83 is perpendicular to the longitudinal path of flow of articles passing therebeneath, and is of a depth as measured upwardly from the surface 77 that is within a range of 1 to 4 times the width of the slotted holes 81 as measured in the longitudinal direction (shortest slotted hole dimension), when preferably sized.

The groove 83 facilitates maintaining the discharge of air or other gas through each of the slotted holes 81, to remain of a width that is evidenced by the dimension "d" in Fig. 6, so that air emanating downwardly therefrom as shown, in the direction of the arrow 84, perpendicular to the path 22 of flow of articles therebeneath will be in the form of a plurality of transversely spaced apart, transversely oriented, planar zones of gas flow.

A plurality of nozzles 85 are also provided in a transverse row, as shown in Figs. 6 and 7, similarly comprising slotted holes spaced apart from each other as shown, also arranged to emanate therefrom, with respect to each slotted hole, a transversely spaced apart transverse, planar zone of gas flow directed toward the path of article travel, of transverse dimension "d". However, the direction of flow of the air or other gas emanating from the nozzles 85, has an upstream component of direction, because of the orientation provided by the angled cut "e" shown in Fig. 7, whereby the groove 86 is cut into the surface 77 at an angle "e", of approximately 30°.

Additionally, it will be noted that the slotted holes 85 in their row aligned with groove 86, are "staggered", relative to the slotted holes 81 in their row aligned with their groove 83, such that the slotted holes 85 are longitudinally aligned with spacings 82, and slotted holes 81 are longitudinally aligned with spacings 89. Thus an article being treated with air or other gas flow does not initially meet an unbroken singular screen of air as it passes beneath the slotted holes 81, but rather, sees a plurality of parallel vertical planar screens of air, and next sees a plurality of screens of air via the slotted holes 85, along longitudinal imaginary ribbons 90 of areas on the surface of the article being treated (see Fig. 2).

-12-

It will also be noted that in Figs. 6 and 7, there is shown a plurality of cylindrical holes 92, connected by a groove 93 in the lower surface 77, which facilitate additional gas flow over the articles being treated. Additionally, another optional row of cylindrical holes 94 may be provided on the downstream end of the plate 94, extending perpendicular to the path of flow 22 of articles passing therebeneath, also connected by a transverse groove 95, as shown in Fig. 7. It will be noted that the holes 94 and grooves 95 are not shown in Fig. 6, in that the same are provided as an option, only.

With reference now to Fig. 8, an alternative arrangement is provided for gas or other air discharge dispensers 120,121, in the form of upper and lower nozzle plates 174 carried by associated manifolds. The rows of slotted holes 181,185 and their respective lower grooves 183,186 are essentially the same as those for the rows of slotted holes 81,85 and associated grooves described above with respect to the embodiment of Figs. 6 and 7, so the same will not be duplicated herein. However, it will be noted that the upstream orientation of air discharged via nozzle openings 185 and associated groove 186 creates a partial vacuum as shown by the arrow 190. The lower surface 177 of the plate 174 in this embodiment is sloped, rather than being parallel to the path of flow 22 of articles being conveyed therepast, such that it converges from a downstream portion 180 thereof toward an upstream portion 178 thereof. Such convergence increases the velocity of flow of air past a through-hole 200 in the article 111 being conveyed therepast. If the upper and lower slotted holes in upper and lower ones of the plates 174 are staggered transversely, such that a given hole is impinged upon by air being discharged from either an upper or lower slotted hole, but not both at the same time, a pumping action can be effected whereby air will pass either upwardly or downwardly through the slotted hole 200, but not in both directions at the same time. Such pumping action created by the relative placement of upper and lower slotted holes in upper and lower plates 174, at higher velocities caused by the converging surfaces 177, and angled discharge groove 186, facilitate moving fluid upwardly and downwardly through through-holes 200.

-13-

With reference now to Figs. 9 and 10, it will be seen that a nozzle plate 300 is provided, being illustrated in longitudinal vertical section, and being comprised of a nozzle base section 301 and a removable nozzle section 302 disposed therein, with portions of the nozzle base section overlying portions of the removable nozzle section at 303 and 304, in transverse dovetail joint arrangements as shown in Fig. 9, with the joints 305, 306, formed thereby extending in a transverse direction, and with transverse elastomeric seals 307, 308, of the O-ring type being shown, sealing removable section 302 to the base section 301, as shown. It will be seen that the nozzle orifices 310 are contained within the removable nozzle section 302. Thus, fluid, preferably liquid, may flow upwardly in the nozzle as shown in Fig. 9, in the direction of the arrows 311, out of the orifices 310, in the manner described above.

However, the removable nozzle section 302 may be removed for cleaning or the like, in the event that thin films of treatment materials, or scaling occurs, for ready cleaning of those portions of the nozzle plates that contain the orifices, without requiring substantial disassembly of major portions of the equipment.

It will be apparent that while only a lower nozzle plate 300 is illustrated, an upper nozzle plate of the same general configuration would normally be disposed thereabove, with the path of travel of articles being treated taking place therebetween, and running from left to right, or right to left, as viewed in Fig. 9.

With reference to Fig. 10, it will be seen that end plates 312 are provided at each end of the removable nozzle sections 302, generally fastened to the nozzle base section 301 by means of suitable fasteners 313, as shown, and with longitudinally disposed O-rings 314 carried by the plates 312, generally connecting seals 307 and 308, such that the plate 302 is sealed entirely about its periphery. It will be apparent that the seals 307, 308 and 314 may comprise individual seals, or the same may comprise a single endless seal, as may be desired. Also, while only one end plate 312 and seal 314 is shown in Fig. 10, it will be understood that generally a comparable plate and seal would be provided on the opposite end of the removable plate section 302.

-14-

Thus, it will be apparent that the removable plate sections may readily be removed for cleaning or the like, and they may readily be re-assembled into the equipment. Also, it will be apparent that the dovetail joints 305, 306, securely hold the removable sections 302 in opposition to the forces provided by fluid,
5 generally liquid (or although the same may be gas) flowing in the direction of the arrows 311.

With reference now to Figs. 11-13, it will be seen that a nozzle plate 400 is provided with a plurality of nozzles 401, connected by a transverse groove 402 extending into the orifices 404 at a depth 403, and having a longitudinal width D1,
10 and the angled sides of the groove 402 having an included angle "f" therebetween, as shown in Fig. 11. In Fig. 11, the center line of the groove 404 and the center line of the nozzle orifices or openings 404 are one and the same, at 405.

With reference to Fig. 12, it will be seen that the discharge of liquid from the orifices 404 of the nozzles, is along the center line 405, upwardly, as shown in
15 the direction of the arrow 406, in the form of a column 407 of fluid diagrammatically illustrated as such in Fig. 12, and would be the same for each of the many nozzle orifices 404 that are connected by the transverse groove 402. The angle of discharge for the column 407 is shown at "g", to be at 90° from the nozzle surface 408, which would be at the same angle "g" to the longitudinal path
20 of flow of articles between pairs of nozzle plates 400.

With reference now to Fig. 13, it will be seen that the nozzle plate 500 is constructed such that the transverse center line 505, connecting a plurality of discharge orifices 504 transversely of the equipment, is at a different location longitudinally of the path of flow of articles to be treated by the equipment than the
25 center line 509 of the transverse groove 502 that connects a plurality of nozzle orifices 504 transversely of the equipment. Also, with respect to Fig. 13, it will be noted that the angle "h" to the horizontal surface 508 that the diagrammatically illustrated column 507 of fluid being discharged from nozzle orifices 504, in the direction of the arrow 506, is seen to be acute, as shown in Fig. 13.

30 The distance between line 505 and 509 can vary, preferably within a range

-15-

of 0.0 inches 0.020 inches, and the angle "h" can vary generally from about 70° to about 90°.

It will be apparent from the foregoing that various modifications may be made in the details of construction, as well as in the use and operation of the apparatus and method in accordance with this invention.

5

-16-

Claims

What is claimed is:

1. Apparatus for fluid treatment of articles being conveyed along a pre-determined generally longitudinal path, comprising means for conveying articles along a pre-determined longitudinal path from an upstream direction toward a downstream direction, and:
 - (a) a first fluid dispenser manifold arranged generally transverse to said generally longitudinal path;
 - (b) a second fluid dispenser manifold arranged generally transverse to said generally longitudinal path;
 - (c) said first and second fluid dispenser manifolds being disposed generally opposite each other with the longitudinal article path therebetween;
 - (d) with said first and second fluid dispenser manifolds having respectively associated first and second multi-port fluid dispenser nozzle plates disposed generally transverse of and adjacent to said path, with one said nozzle plate on each side of said path and terminating in a nozzle plate surface nearest said path;
 - (e) with at least one of said first and second nozzle plates having at least one generally transverse row of nozzle openings for dispensing fluid from an associated said manifold therethrough, into contact with articles being conveyed along the predetermined path;
 - (f) transverse groove means extending transverse of said longitudinal path along said nozzle plate surface, connecting the nozzle openings in said nozzle plate surface nearest said path;
 - (g) with said row of nozzle openings and said transverse

- groove means cooperating to comprise means for providing a transversely extending screen of fluid flow from said nozzle openings; and
- (h) with said nozzle plate being comprised of a base section and a removable nozzle section, with said nozzle openings being disposed in said removable nozzle section.

2. Apparatus for fluid treatment of articles being conveyed along a pre-determined generally longitudinal path, comprising means for conveying articles along a pre-determined longitudinal path from an upstream direction toward a downstream direction, and:

- (a) a first fluid dispenser manifold arranged generally transverse to said generally longitudinal path;
- (b) a second fluid dispenser manifold arranged generally transverse to said generally longitudinal path;
- (c) said first and second fluid dispenser manifolds being disposed generally opposite each other with the longitudinal article path therebetween;
- (d) with said first and second fluid dispenser manifolds having respectively associated first and second fluid dispenser nozzle plates disposed generally transverse of and adjacent to said path, with one said nozzle plate on each side of said path and terminating in a nozzle plate surface nearest said path;
- (e) with at least one of said first and second nozzle plates having nozzle openings for dispensing fluid from an associated said manifold therethrough, into contact with articles being conveyed along the predetermined path; and

-18-

- (f) with said nozzle plate being comprised of a base section and a removable nozzle section, with said nozzle openings being disposed in said removable nozzle section.

3. The apparatus of any one of claims 1 and 2, wherein said base section of said nozzle plate and said removable nozzle section of said nozzle plate are disposed adjacent each other along at least one generally transverse joint.

4. The apparatus of claim 3, wherein at least one portion of said base section is in overlying relation to at least one portion of said removable nozzle section, comprising means resisting separation of said nozzle section from said base section at said joint during flow of fluid from nozzles.

5. The apparatus of claim 4, wherein an elastomeric seal is provided in said joint, in sealing engagement between said base section and said removable nozzle section.

6. The apparatus of claim 5, wherein said seal comprises an O-ring.

7. The apparatus of claim 3, wherein there are two generally transverse joints between said base section and said removable nozzle section along both sides of said removable nozzle sections, with an elastomeric seal in each said joint, in sealing engagement between said base section and said removable nozzle section.

8. The apparatus of claim 7, wherein said joints comprise dovetail sections.

9. The apparatus of claim 8, wherein at least one portion of said base section is in overlying relation to at least one portion of said removable nozzle section, comprising means resisting separation of said removable nozzle section

-19-

from said base section at said joint during flow of fluid from nozzles and wherein an elastomeric seal is provided in said joint, in sealing engagement between said base section and said removable nozzle section.

10. The apparatus of claim 7, including end plates along ends of said base section and removable nozzle section, with elastomeric seals between said end plates and adjacent portions of said removable nozzle sections.

11. Apparatus for fluid treatment of articles being conveyed along a pre-determined generally longitudinal path, comprising means for conveying articles along a pre-determined longitudinal path from an upstream direction toward a downstream direction, and:

- (a) a first fluid dispenser manifold arranged generally transverse to said generally longitudinal path;
- (b) a second fluid dispenser manifold arranged generally transverse to said generally longitudinal path;
- (c) said first and second fluid dispenser manifolds being disposed generally opposite each other with the longitudinal article path therebetween;
- (d) with said first and second fluid dispenser manifolds having respectively associated first and second multi-port fluid dispenser nozzle plates disposed generally transverse of and adjacent to said path, with one said nozzle plate on each side of said path and terminating in a nozzle plate surface nearest said path;
- (e) with at least one of said first and second nozzle plates having at least one generally transverse row of nozzle openings for dispensing fluid from an associated said manifold therethrough, into contact with articles being conveyed along the predetermined path;

- (f) transverse groove means extending transverse of said longitudinal path along said nozzle plate surface, connecting the nozzle openings in said nozzle plate surface nearest said path;
- (g) with said row of nozzle openings and said transverse groove means cooperating to comprise means for providing a transversely extending screen of fluid flow from said nozzle openings;
- (h) with the transverse groove means having a transverse center line at first location along said predetermined path;
and
- (i) with the row of nozzle openings having a transverse center line at a second location along said predetermined path, different from said first location.

12. The apparatus of claim 11, wherein the distance between said first and second locations along said predetermined path is up to about 0.020 inches.

13. Apparatus for fluid treatment of articles being conveyed along a pre-determined generally longitudinal path, comprising means for conveying articles along a pre-determined longitudinal path from an upstream direction toward a downstream direction, and:

- (a) a first fluid dispenser manifold arranged generally transverse to said generally longitudinal path;
- (b) a second fluid dispenser manifold arranged generally transverse to said generally longitudinal path;
- (c) said first and second fluid dispenser manifolds being disposed generally opposite each other with the longitudinal article path therebetween;
- (d) with said first and second fluid dispenser manifolds

having respectively associated first and second multi-port fluid dispenser nozzle plates disposed generally transverse of and adjacent to said path, with one said nozzle plate on each side of said path and terminating in a nozzle plate surface nearest said path;

- (e) with at least one of said first and second nozzle plates having at least one generally transverse row of nozzle openings for dispensing fluid from an associated said manifold therethrough, into contact with articles being conveyed along the predetermined path;
- (f) transverse groove means extending transverse of said longitudinal path along said nozzle plate surface, connecting the nozzle openings in said nozzle plate surface nearest said path;
- (g) with said row of nozzle openings and said transverse groove means cooperating to comprise means for providing a transversely extending screen of fluid flow from said nozzle openings; and
- (h) with said transverse groove means having an upstanding center line that is at an acute angle to said longitudinal path.

14. The apparatus of claim 13, wherein said acute angle is between about 70° and about 90°.

15. The apparatus of claim 11, with said transverse groove means having an upstanding center line that is at an acute angle to said longitudinal path.

16. The apparatus of claim 15, wherein the distance between said first and second locations along said predetermined path is up to about 0.020 inches and

-22-

wherein said acute angle is between about 70° and about 90°.

17. The apparatus of claim 11, with said nozzle plate being comprised of a base section and a removable nozzle section, with said nozzle openings being disposed in said removable nozzle section.

18. The apparatus of claim 17, and wherein said base section of said nozzle plate and said removable nozzle section of said nozzle plate are disposed adjacent each other along at least one generally transverse joint.

19. The apparatus of claim 18, wherein at least one portion of said base section is in overlying relation to at least one portion of said removable nozzle section, comprising means resisting separation of said removable nozzle section from said base section at said joint during flow of fluid from nozzles and wherein an elastomeric seal is provided in said joint, in sealing engagement between said base section and said removable nozzle section.

20. A method fluid treatment of articles being conveyed along a pre-determined generally longitudinal path, comprising conveying articles along a pre-determined longitudinal path from an upstream direction toward a downstream direction, and:

- (a) providing a first fluid dispenser manifold arranged generally transverse to said generally longitudinal path;
- (b) providing a second fluid dispenser manifold arranged generally transverse to said generally longitudinal path;
- (c) disposing the first and second fluid dispenser manifolds generally opposite each other with the longitudinal article path therebetween;

- (d) with first and second fluid dispenser manifolds having respectively associated first and second multi-port fluid dispenser nozzle plates; disposing the nozzle plates generally transverse of and adjacent to said path, with one said nozzle plate on each side of said path and terminating in a nozzle plate surface nearest said path;
- (e) with at least one of said first and second nozzle plates having at least one generally transverse row of nozzle openings for dispensing fluid from an associated said manifold therethrough, into contact with articles being conveyed along the predetermined path;
- (f) providing transverse groove means extending transverse of said longitudinal path along said nozzle plate surface, and connecting the nozzle openings in said nozzle plate surface nearest said path;
- (g) providing a transversely extending screen of fluid flow from said nozzle openings via the transverse groove means; and
- (h) with said nozzle plate being comprised of a base section and a removable nozzle section, with said nozzle openings being disposed in said removable nozzle section, and removing the removable nozzle section from the base section.

21. A method of fluid treatment of articles being conveyed along a pre-determined generally longitudinal path, comprising means for conveying articles along a pre-determined longitudinal path from an upstream direction toward a downstream direction, and:

- (a) providing a first fluid dispenser manifold arranged

-24-

- generally transverse to said generally longitudinal path;
- (b) providing a second fluid dispenser manifold arranged generally transverse to said generally longitudinal path;
 - (c) disposing the first and second fluid dispenser manifolds generally opposite each other with the longitudinal article path therebetween;
 - (d) with the first and second fluid dispenser manifolds having respectively associated first and second fluid dispenser nozzle plates; disposing the nozzle plates generally transverse of and adjacent to said path, with one said nozzle plate on each side of said path and terminating in a nozzle plate surface nearest said path;
 - (e) with at least one of said first and second nozzle plates having nozzle openings for dispensing fluid from an associated said manifold therethrough, into contact with articles being conveyed along the predetermined path; and
 - (f) with said nozzle plate being comprised of a base section and a removable nozzle section, with said nozzle openings being disposed in said removable nozzle section, and removing the removable nozzle section from the base section for cleaning or the like.

22. The method of any one of claims 20 and 21, wherein said base section of said nozzle plate and said removable nozzle section of said nozzle plate are disposed adjacent each other along at least one generally transverse joint.

23. The apparatus of claim 22, including providing an elastomeric seal

-25-

in said joint, in sealing engagement between said base section and said removable nozzle section.

24. The method of claim 22, including providing end plates along ends of said base section and removable nozzle section, with elastomeric seals between said end plates and adjacent portions of said removable nozzle sections.

25. A method of fluid treatment of articles being conveyed along a pre-determined generally longitudinal path, comprising conveying articles along a pre-determined longitudinal path from an upstream direction toward a downstream direction, and:

- (a) providing a first fluid dispenser manifold arranged generally transverse to said generally longitudinal path;
- (b) providing a second fluid dispenser manifold arranged generally transverse to said generally longitudinal path;
- (c) disposing the first and second fluid dispenser manifolds being disposed generally opposite each other with the longitudinal article path therebetween;
- (d) with the first and second fluid dispenser manifolds having respectively associated first and second multi-port fluid dispenser nozzle plates; disposing the nozzle plates generally transverse of and adjacent to said path, with one said nozzle plate on each side of said path and terminating in a nozzle plate surface nearest said path;
- (e) with at least one of said first and second nozzle plates having at least one generally transverse row of nozzle openings for dispensing fluid from an associated said

manifold therethrough, into contact with articles being conveyed along the predetermined path;

- (f) providing transverse groove means extending transverse of said longitudinal path along said nozzle plate surface and connecting the nozzle openings in said nozzle plate surface nearest said path;
- (g) providing a transversely extending screen of fluid flow from said nozzle openings via the transverse grooves means;
- (h) providing the transverse groove means having a transverse center line at first location along said predetermined path; and
- (i) providing the row of nozzle openings having a transverse center line at a second location along said predetermined path, different from said first location.

26. A method of fluid treatment of articles being conveyed along a predetermined generally longitudinal path, comprising conveying articles along a predetermined longitudinal path from an upstream direction toward a downstream direction, and:

- (a) providing a first fluid dispenser manifold arranged generally transverse to said generally longitudinal path;
- (b) providing a second fluid dispenser manifold arranged generally transverse to said generally longitudinal path;
- (c) disposing the first and second fluid dispenser manifolds generally opposite each other with the longitudinal article path therebetween;
- (d) with the first and second fluid dispenser manifolds

having respectively associated first and second multi-port fluid dispenser nozzle plates; disposing the nozzle plates generally transverse of and adjacent to said path, with one said nozzle plate on each side of said path and terminating in a nozzle plate surface nearest said path;

- (e) with at least one of said first and second nozzle plates having at least one generally transverse row of nozzle openings for dispensing fluid from an associated said manifold therethrough, into contact with articles being conveyed along the predetermined path;
- (f) providing transverse groove means extending transverse of said longitudinal path along said nozzle plate surface and connecting the nozzle openings in said nozzle plate surface nearest said path;
- (g) providing a transversely extending screen of fluid flow from said nozzle openings via the transverse grooves means; and
- (h) providing transverse groove means having an upstanding center line at an acute angle to said longitudinal path.

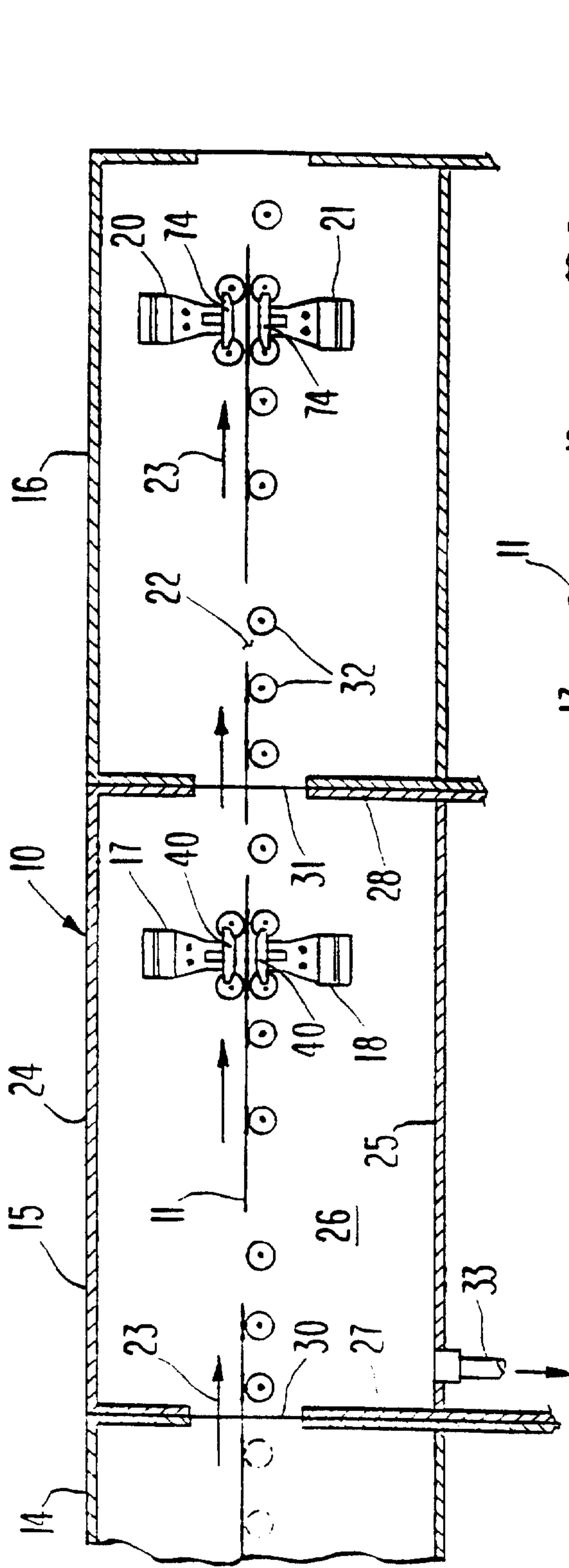

Fig. 1

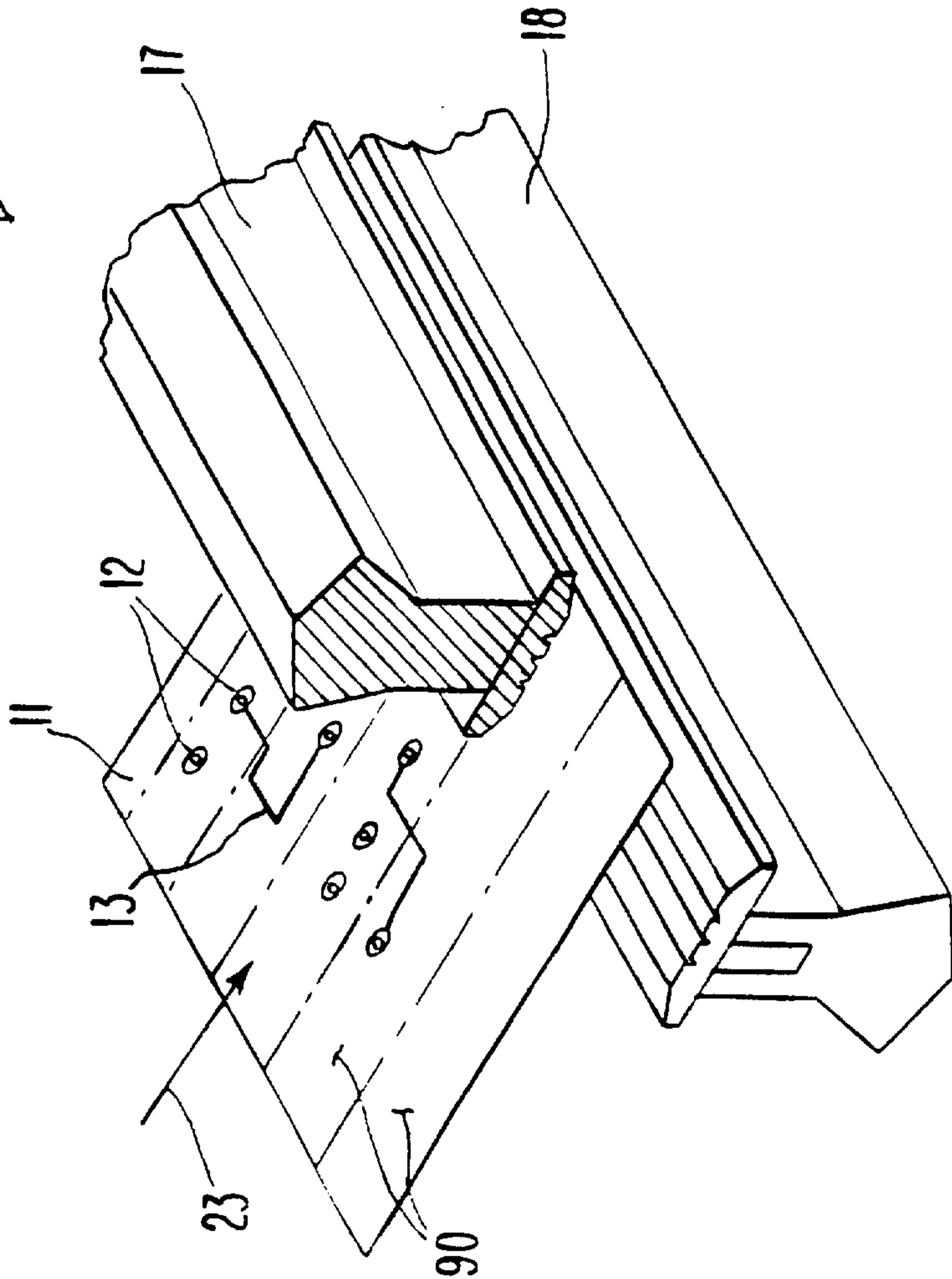

Fig. 2

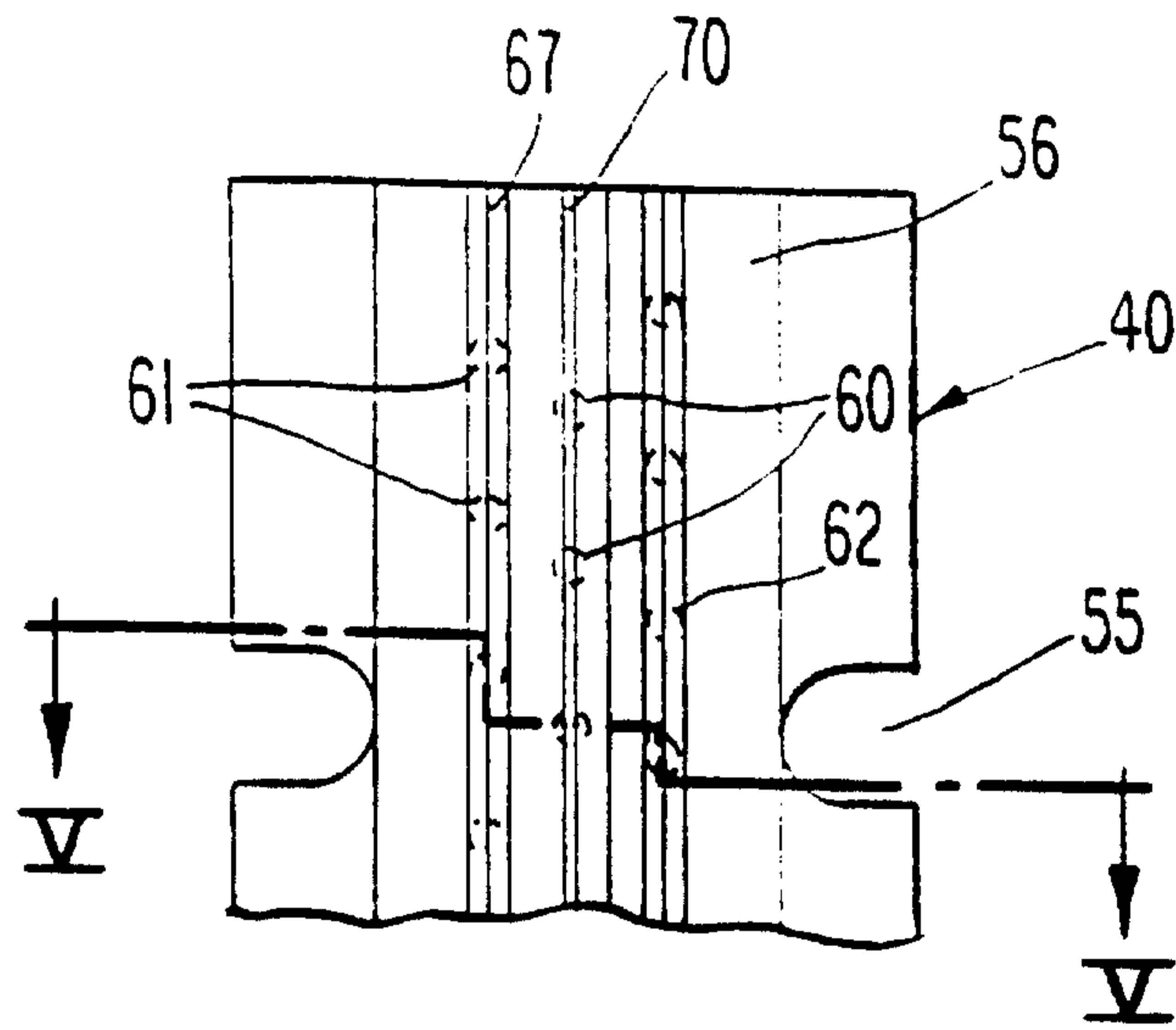

Fig. 4

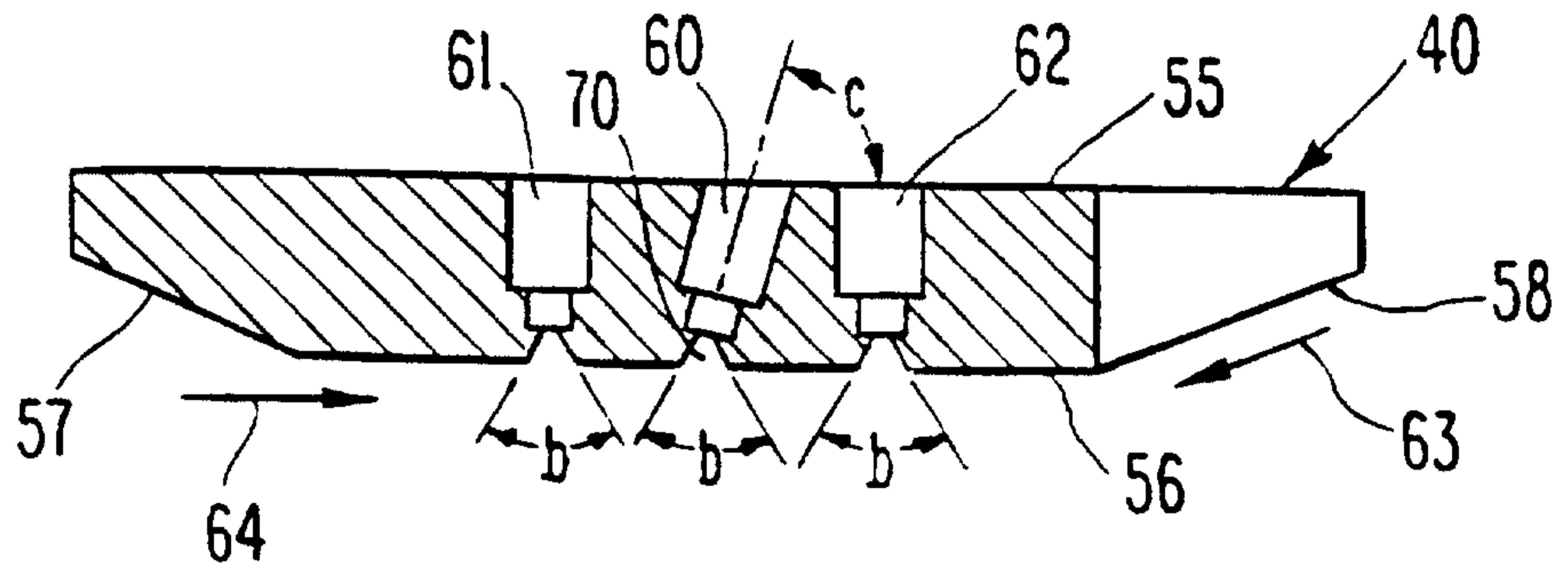

Fig. 5

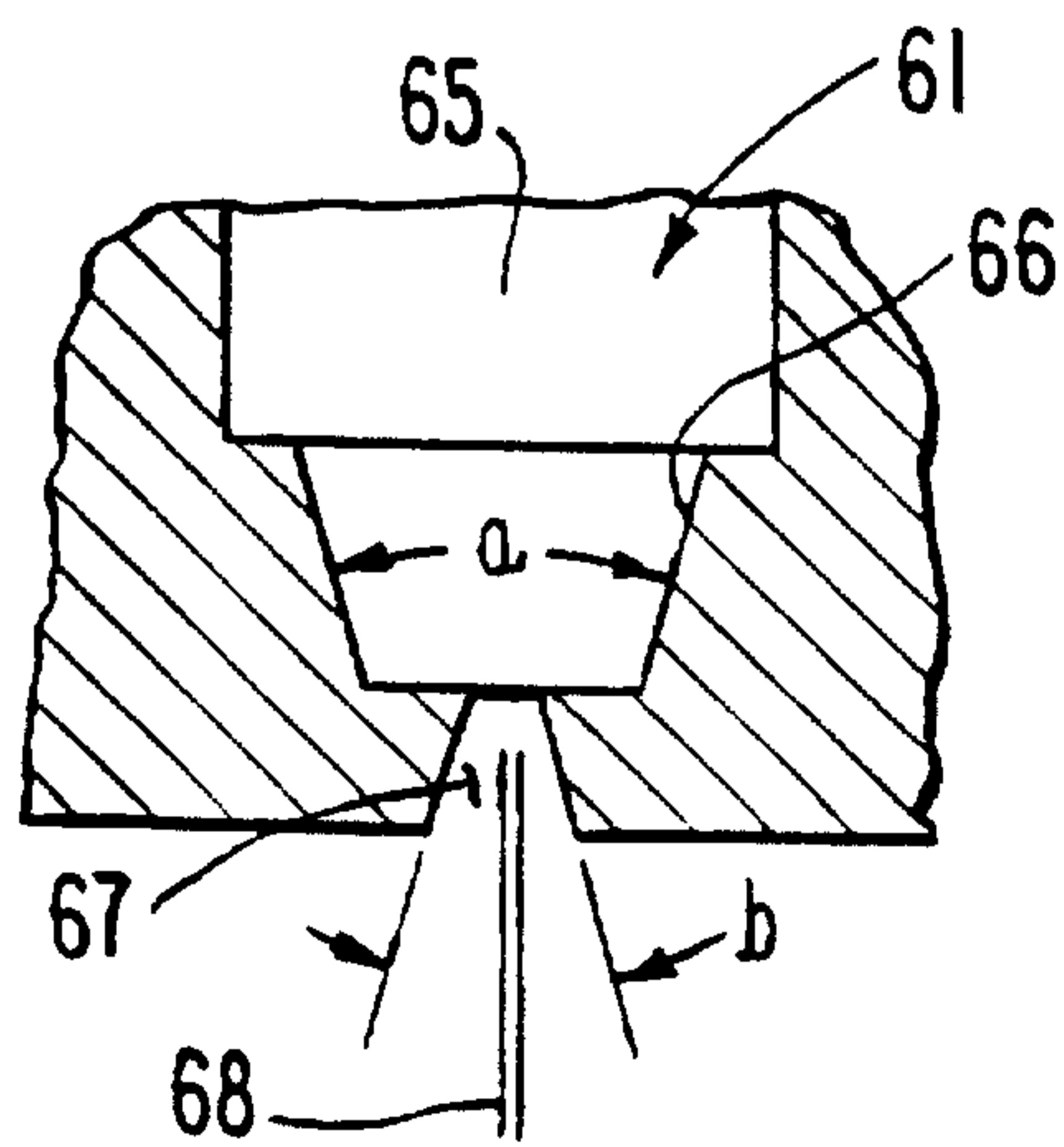

Fig. 5A

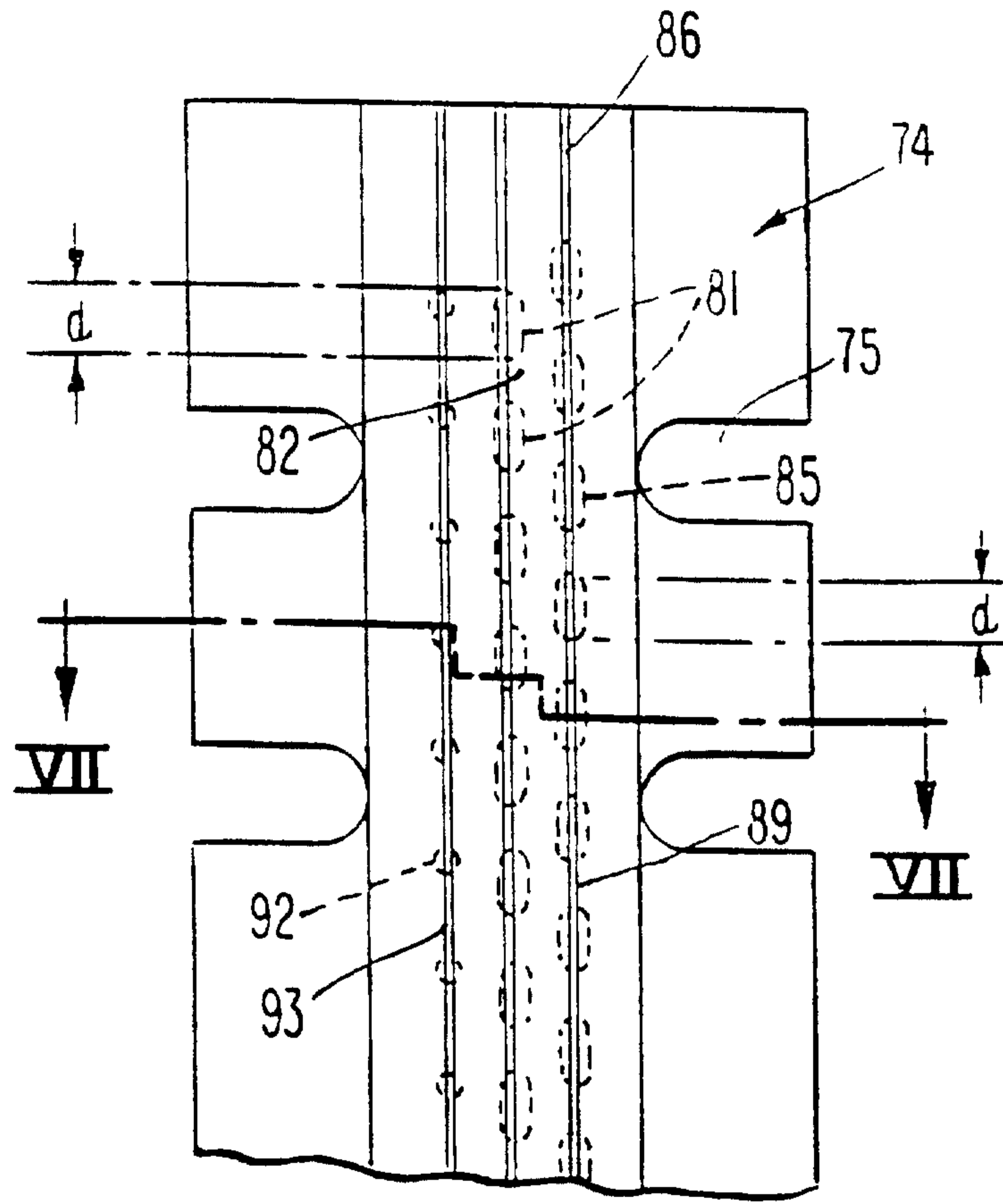

Fig. 6

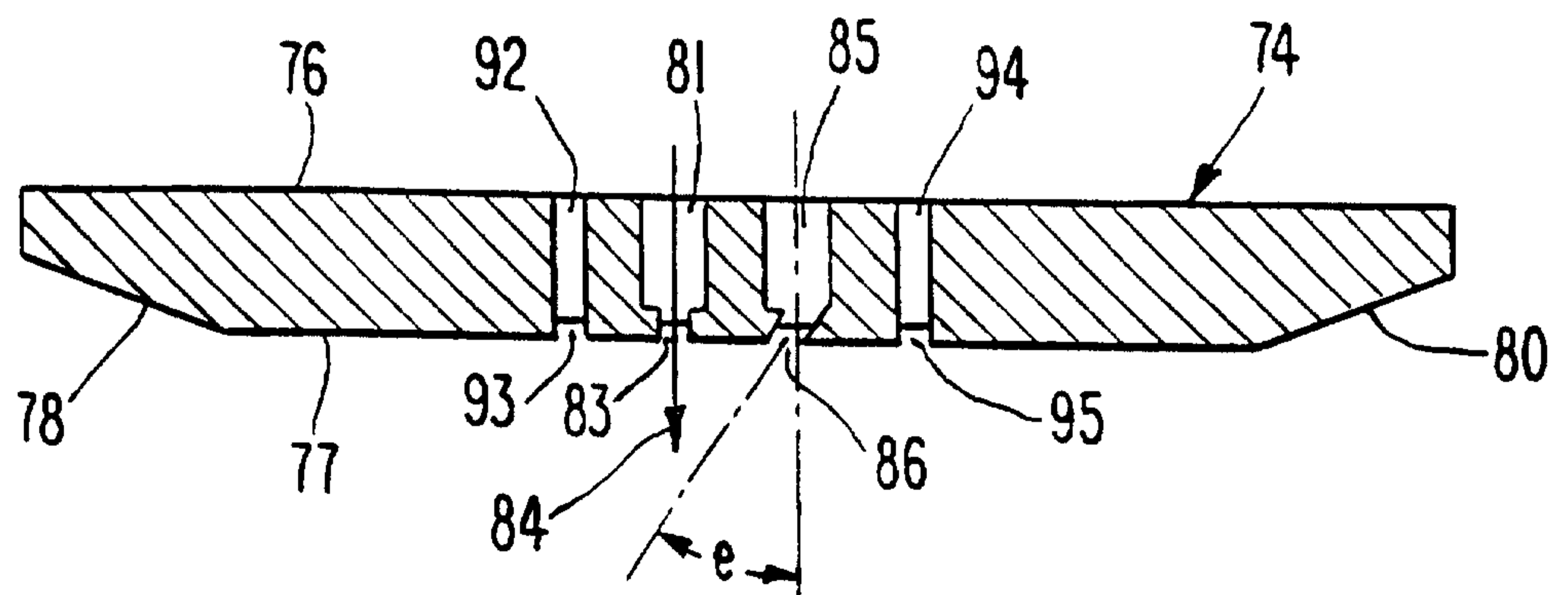

Fig. 7

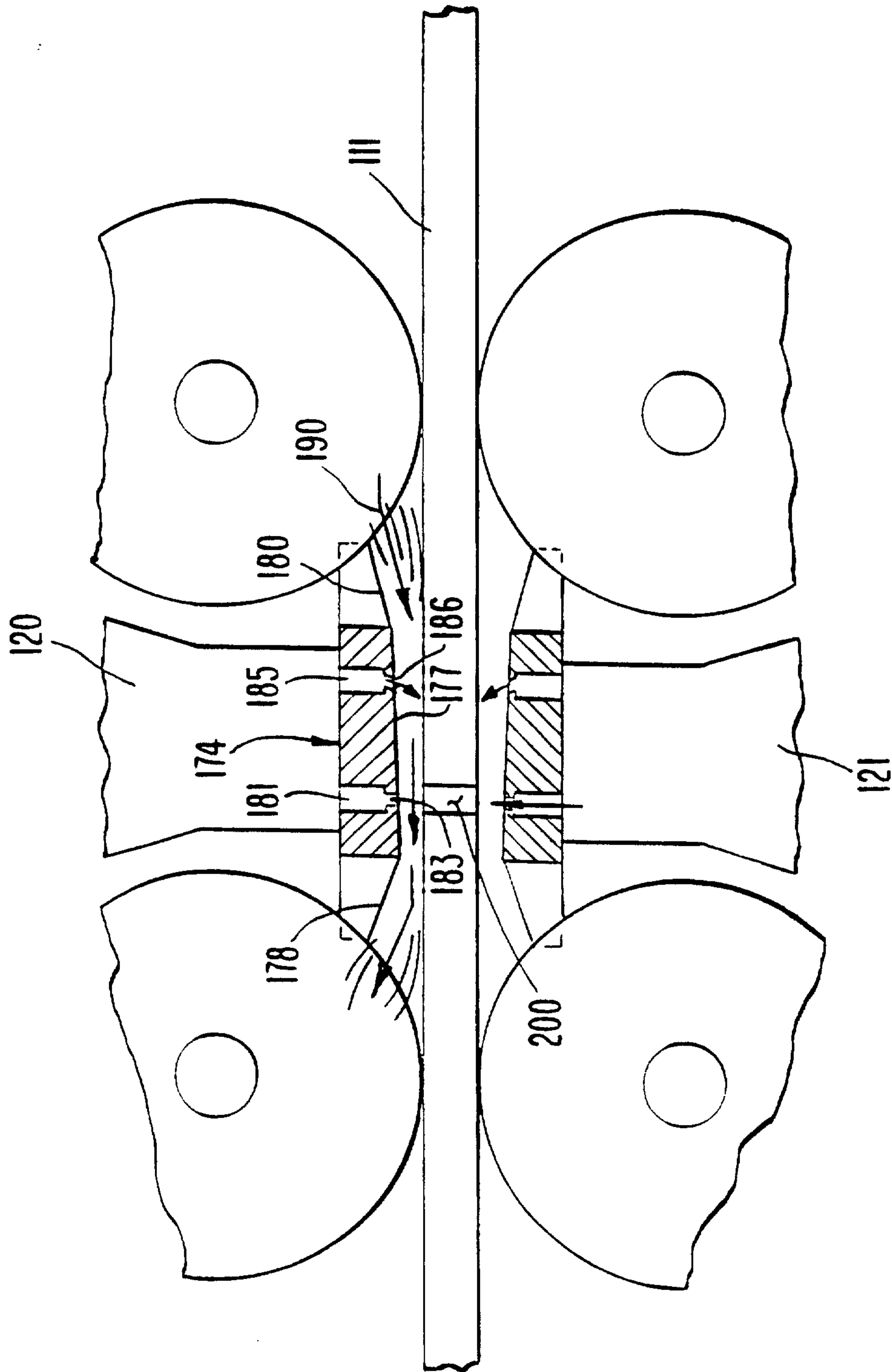

Fig. 8

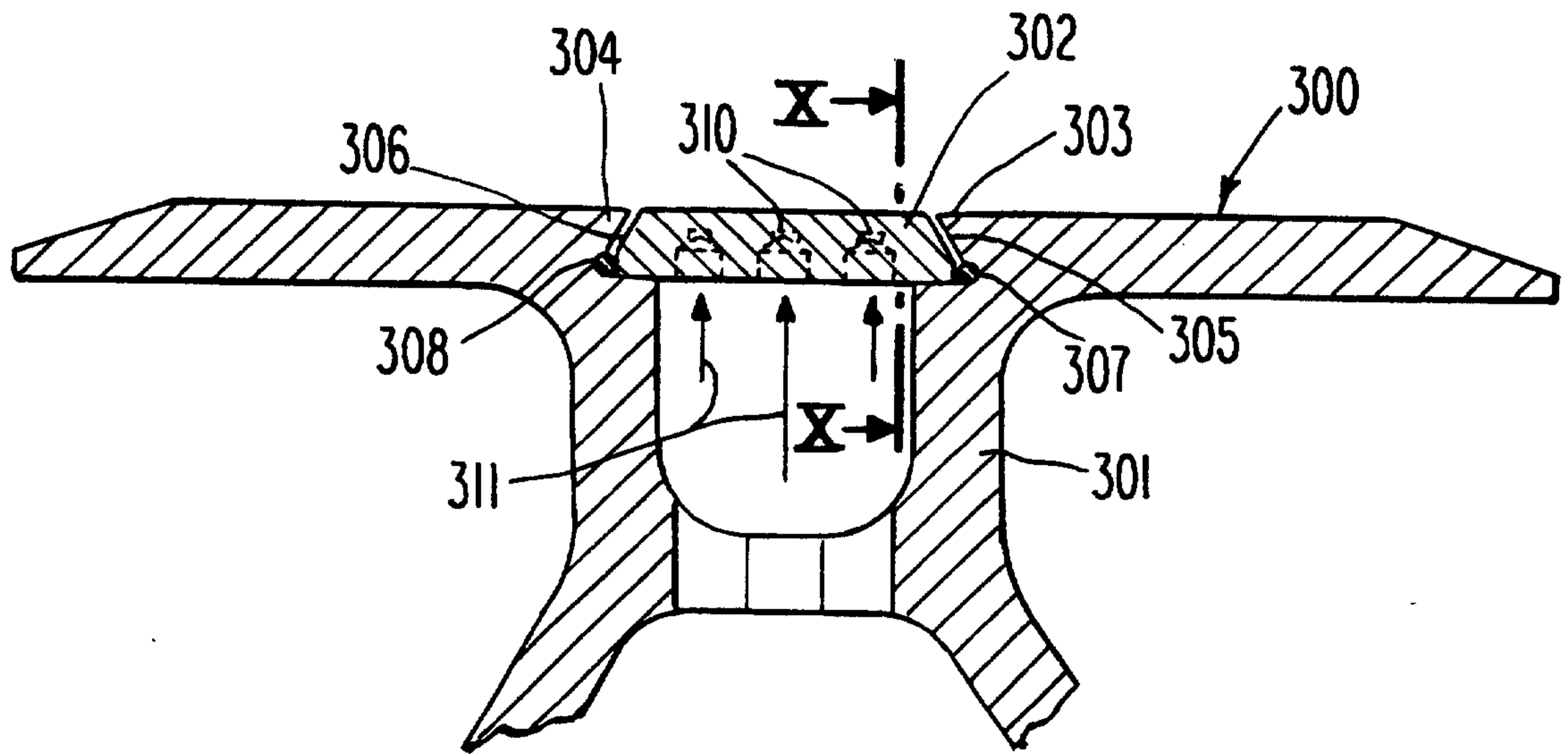

Fig. 9

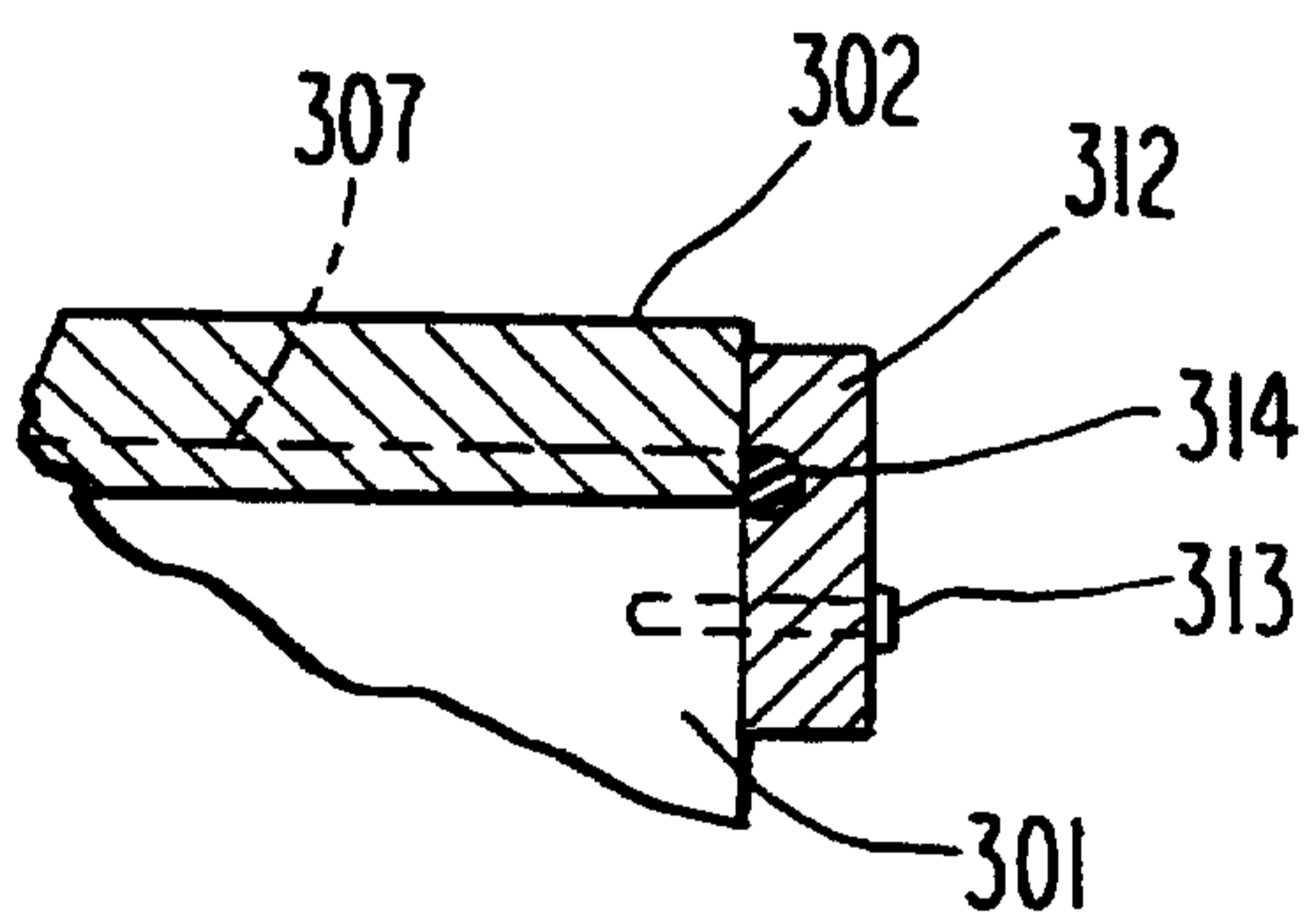

Fig. 10

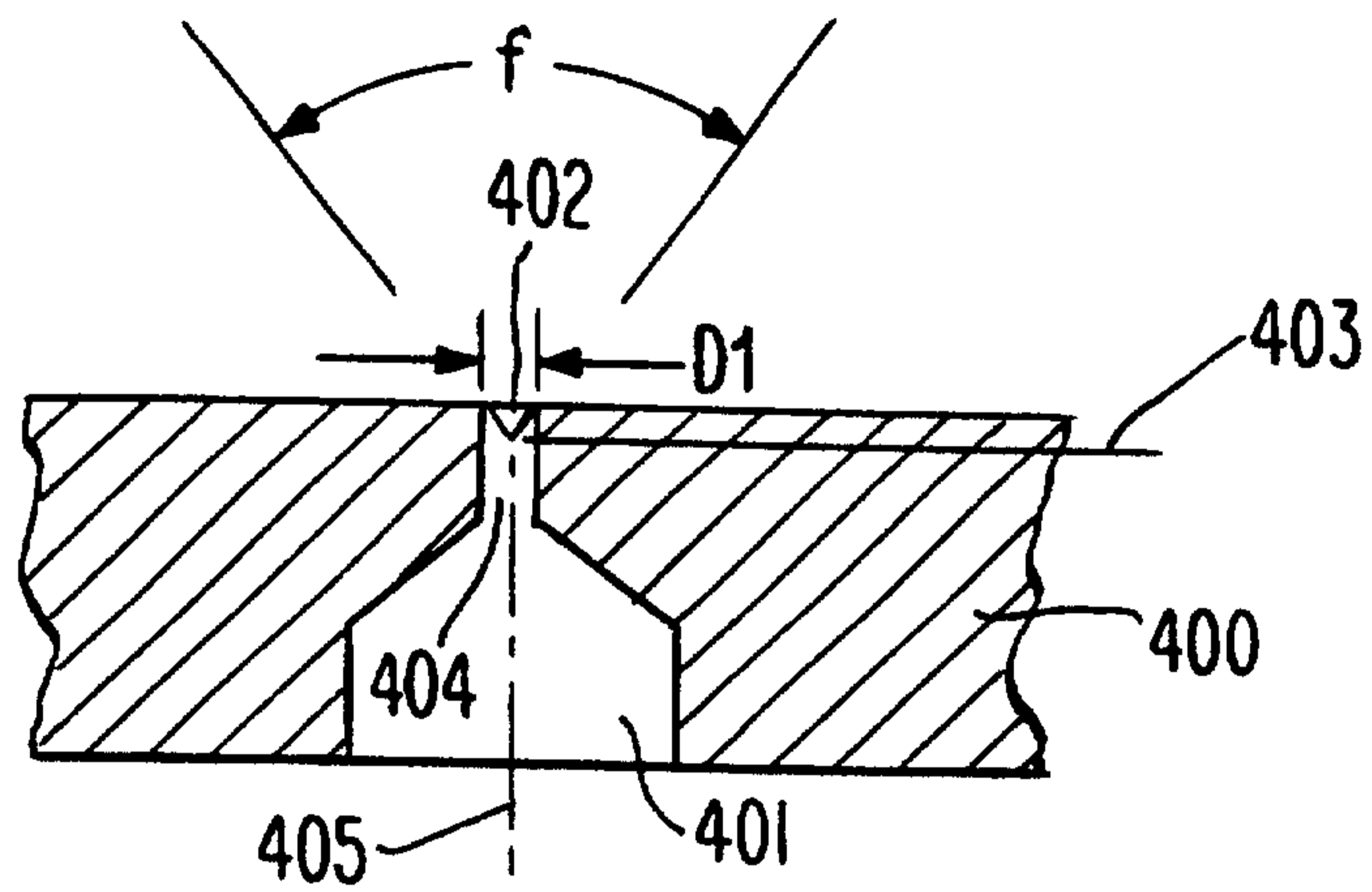

Fig. 11

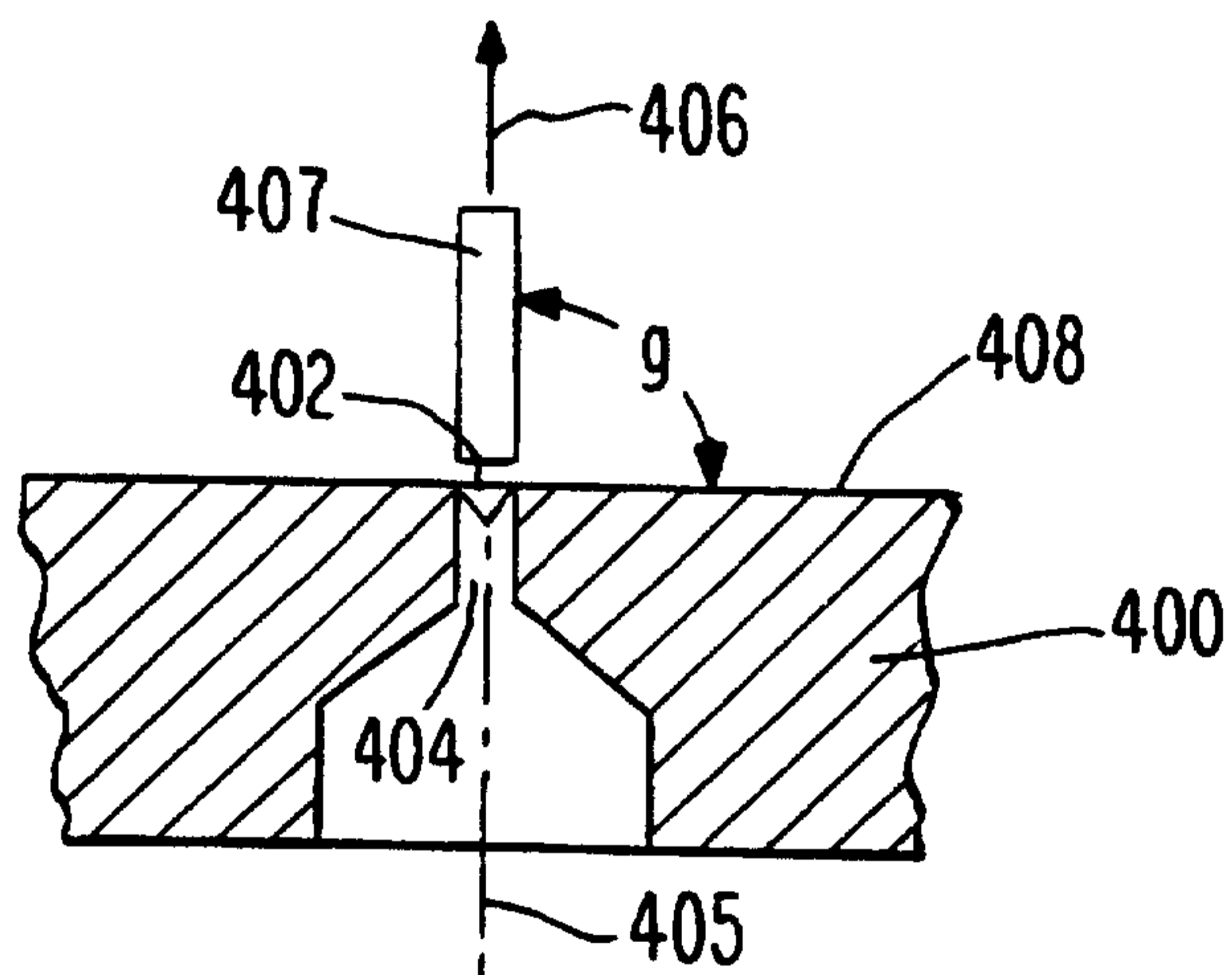

Fig. 12

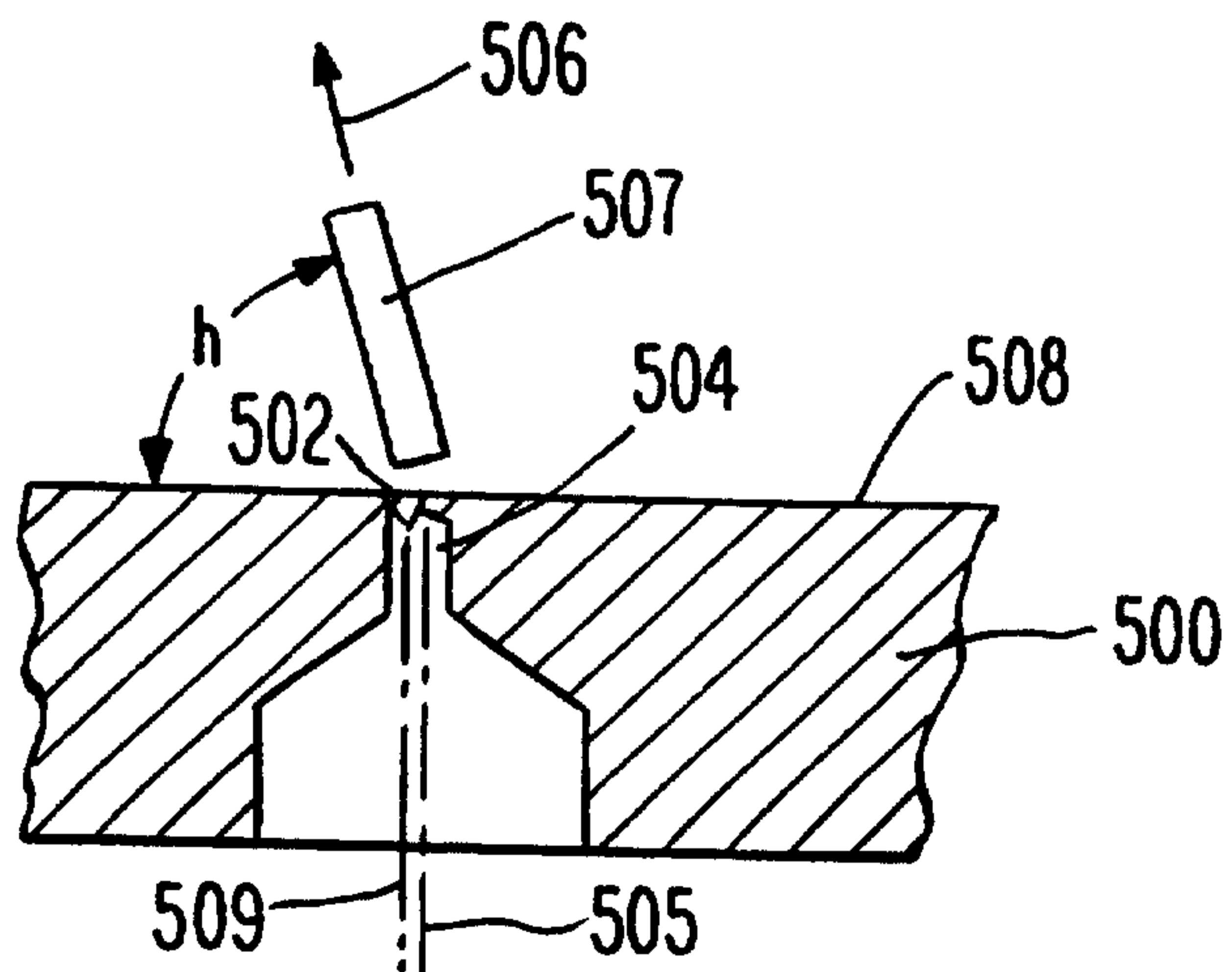

Fig. 13