

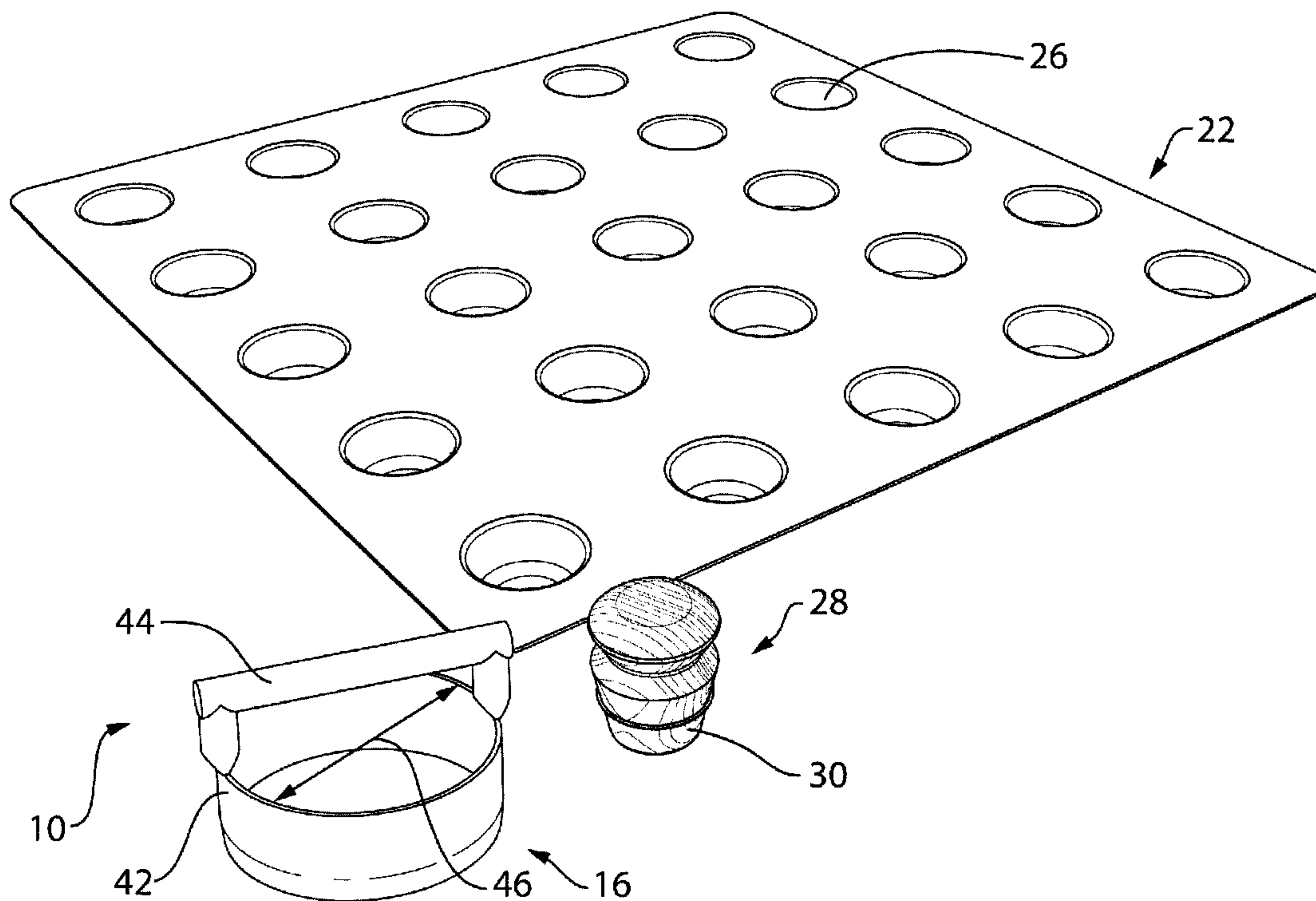

(22) Date de dépôt/Filing Date: 2007/08/20  
(41) Mise à la disp. pub./Open to Public Insp.: 2009/02/20  
(45) Date de délivrance/Issue Date: 2012/08/07

(51) Cl.Int./Int.Cl. *A21C 11/10* (2006.01),  
*A21C 11/00* (2006.01)  
(72) Inventeur/Inventor:  
CURTIS, MARTIN DALE JR., CA  
(73) Propriétaire/Owner:  
CURTIS, MARTIN DALE JR., CA

(54) Titre : DISPOSITION ET METHODE APPLICABLES A UNE PRESSE A PATISSERIE  
(54) Title: PASTRY PRESS ARRANGEMENT AND METHOD



(57) Abrégé/Abstract:

There is provided, an arrangement and a method to form a dough article having, a cutter for cutting a dough blank or sheet into dough sections; a molded pan that has at least one female depression; and a male portion, the male portion has a first indication surface to provide a fill mark on a dough section when the male portion forces the dough section into a female depression.



ABSTRACT

There is provided, an arrangement and a method to form a dough article having, a cutter for cutting a dough blank or sheet into dough sections; a molded pan that has at least one female depression; and a male portion, the male portion has a first indication surface to provide a fill mark on a dough section  
5 when the male portion forces the dough section into a female depression.

PASTRY PRESS ARRANGEMENT AND METHOD

## FIELD OF THE INVENTION

5 The present invention relates to an arrangement and method to form a dough article, more particularly but not necessarily exclusively, butter tarts.

## DESCRIPTION OF THE RELATED ART

10 Conventionally, a home baker or in small bakery a baker hand manipulates a pastry dough, by initially rolling the dough into a flat sheet or blank, cutting the dough into circular pieces then pressing with their fingers against the bottom and side wall of a shelled pan to form a pastry shell. Care must be taken to use enough pastry and evenly and adequately spread the dough to cover the entire shell cavity. That effort is time consuming because of the manual movement to the dough material, mental calculations and

15 estimations required. This process is very slow and the results are unfortunately not uniform since the thickness of the shell can vary leading to difficulties in further processing and leading to an inconsistent product. Further, there is a problem of correctly filling the pastry shells with a filler product. If too much is added there is a problem during the baking process. The filler may overflow from the pastry shell with a result that it causes burning and sticking to the pan.

20

Therefore, it would be desirable to address at least some of these problems.

## BRIEF DESCRIPTION OF THE DRAWINGS

25 Several preferred embodiments of the present invention will be provided, by way of examples only, with reference to the appended drawings, wherein,

Figure 1 is a top perspective view of an arrangement to form a dough article;

Figures 2, 3, 4a, 4b, 5a and 5b are fragmentary perspective or side operational views of a method of making a pastry article;

Figures 6 and 7 are top perspective views of kits; and

5

Figure 8 is a side view of an alternative portion of the arrangement of figure 1.

#### DESCRIPTION OF THE PREFERRED EMBODIMENTS

10 It should be understood that the invention is not limited in its application to the details of construction and the arrangement of components set forth in the following description or illustrated in the drawings. The invention is capable of other embodiments and of being practiced or of being carried out in various ways. Also, it is to be understood that the phraseology and terminology used herein is for the purpose of description and should not be regarded as limiting. The use of "including," "comprising," or "having" and  
 15 variations thereof herein is meant to encompass the items listed thereafter and equivalents thereof as well as additional items. Unless limited otherwise, the terms "connected," "coupled," and "mounted," and variations thereof herein are used broadly and encompass direct and indirect connections, couplings, and mountings. In addition, the terms "connected" and "coupled" and variations thereof are not restricted to physical or mechanical connections or couplings. Furthermore, and as described in subsequent paragraphs,  
 20 the specific mechanical configurations illustrated in the drawings are intended to exemplify embodiments of the invention. However, other alternative mechanical configurations are possible which are considered to be within the teachings of the instant disclosure. Furthermore, unless otherwise indicated, the term "or" is to be considered inclusive.

25 As will expanded upon below with reference to the figures, there is provided, in one embodiment, an arrangement to form a dough article. The arrangement comprises a cutter for cutting a dough blank into dough sections; a molded plate having at least one female depression; and a male portion. The male portion includes a lateral projection with a first indication surface. The male portion is dimensioned to fit

within the female depression. The male portion includes a lateral projection which is dimensioned relative to the female depression to provide a fill mark on a dough section when the male portion forces the dough section into the female depression.

- 5 In an embodiment, the cutter includes a sharp edged circular walled formation having an inner diameter to provide the dough section with an outer boundary to be located near a top surface of the at least one female depression.

10 In an embodiment, the at least one female depression includes a plurality of female depressions being spaced in a repeating pattern.

In an embodiment, the male portion includes a truncated cone.

15 In an embodiment, the projection includes a ring portion at least partially circumscribing the side wall of the male portion.

In an embodiment, the projection is continuous, while in an alternative embodiment, the projection is discontinuous.

20 In an embodiment, the dough section has a thickness and the male portion has an outer diameter that is smaller than an inner diameter of the at least one female depression to create a cavity equal to the thickness of the dough section.

In another embodiment, there is provided a method of forming a dough article comprising:

- 25
- providing a cutter for cutting a dough blank into dough sections;
  - providing a molded plate having at least one female depression; and

- providing a male portion, the male portion having a first indication surface to provide a fill mark on a dough section when the male portion forces the dough section into a female depression.

5 In another embodiment, there is provided a method of forming a dough article comprising:

-preparing a dough blank,

-cutting the dough blank into dough sections using a cutter;

- preparing a molded plate having at least one female depression to receive a corresponding a dough section;

10 - preparing a male portion with a first indication surface projecting laterally therefrom;  
and

- pressing a dough section into a female depression with the male portion, sufficient to cause the first indication surface to provide a fill mark on the dough section.

15 In another embodiment, there is provided a method of forming a dough article comprising:

-preparing a dough blank,

-cutting the dough blank into dough sections using a cutter;

- preparing a molded plate having at least one female depression to receive a corresponding dough section;

20 - preparing a male portion with a first indication surface projecting laterally therefrom;

- pressing a dough section into a female depression with the male portion, sufficient to cause the first indication surface to provide a fill mark on the dough section;

- preparing a flavoured mixture;

- filling the flavoured mixture into the dough section to the fill mark.

25

In another embodiment, there is provided a tart kit comprising a first package having dough mixture for making a dough blank; a cutter for cutting the dough blank into dough sections; a molded plate having at least one female depression; a male portion, the male portion having a first indication surface to provide a

fill mark on a dough section when the male portion forces the dough section into a female depression; a second package having a filling mixture for a formed dough section and an instructional description and method to use the tart kit.

5 In another embodiment, there is provided a tart kit comprising a cutter for cutting a dough blank into dough sections; a molded plate having at least one female depression; a male portion, the male portion having a first indication surface to provide a fill mark on a dough section when the male portion forces the dough section into a female depression; and an instructional description and method to use the tart kit.

10 In another embodiment, there is provided an arrangement to form a dough article comprising a cutter for cutting a dough blank into dough sections; a molded plate having at least one female depression; and a male portion, the male portion having an outer profile including a downwardly outer tapered side wall and a substantially planar outer bottom wall, the molded plate having an inner profile including a downwardly inner tapered side wall and a substantially planar inner bottom wall, the downwardly tapered outer side  
15 wall being complementary to the downwardly tapered inner side wall, the substantially planar outer bottom wall being complementary with the substantially planar inner bottom wall, in order to form a cavity between the male portion and the female portion for molding a pastry shell therein.

In still another embodiment, there is provided an arrangement to form a dough article comprising a molded  
20 plate having at least one female depression, the molded plate having an upper periphery, the arrangement further comprising a male portion, the male portion having an outer profile including a downwardly outer tapered side wall and a substantially planar outer bottom wall, the molded plate having an inner profile including a downwardly inner tapered side wall and a substantially planar inner bottom wall, the  
25 downwardly tapered outer side wall being complementary to the downwardly tapered inner side wall, the substantially planar outer bottom wall being complementary with the substantially planar inner bottom wall, in order to form a cavity between the male portion and the female portion for molding a pastry shell therein, the male portion further comprising at least one projection extending outwardly from the downwardly outer side wall and in a central region thereof, the male portion and female portions region

being arranged so that the at least one projection is operable to form a fill mark on an inner side surface of the pastry shell.

Referring now to the figures, particularly figure 1 there is provided an arrangement 10 to form a dough  
5 article such as a butter tart. The arrangement includes a cutter 16 for cutting a dough blank or sheet 18 into dough sections 20 as shown in figure 2. As seen in figure 1, there is a molded plate or pan 22 that has at least one, in this case several, female depressions 26; and a male portion 28 which has a first indication surface 30 to provide a fill mark 34 (figure 3) on a dough section 20 when the male portion 28 forces the dough section 20 into a female depression 26 as shown in figures 3 through 5b.

10

The cutter 16 includes a sharp edged circular walled formation 42, but other shaped formations may be used, as desired. In this example, the cutter 16 has a handle 44 and an inner diameter 46 corresponding to an outer diameter 48 (figure 2) of the dough section 20. The outer diameter 48 is selected so that the resulting outer boundary 20a of the dough section 20 will approximately align with, or be located near, a  
15 top surface portion 50 of the depression 26 after the male portion 28 has pressed in the dough section 20 into place, as best illustrated in figure 4b. In this case, the outer boundary 20a is slightly below the top surface 50, though it may also be at or slightly above the top surface portion 50, in some cases.

20

The molded pan 22 may be made of materials that have suitable heat conductivity and thermal capacity for its intended use. For instance, the molded pan 22 may be formed from tin, steel, cast iron, and/or food grade heat resistant plastics materials. The female depressions 26 in this example are spaced in intervals of the same uniform repeating pattern, though other configurations may be used, as desired. Also, in this example the molded pan 22 has been shown with female depressions 26 that are circular, though other shapes and configuration may be used, as desired, provided the male portion is complementary with them.

25

Thus, in this case, the outer profile, dimensions and/or shape of the male portion 28 and the inner profile, dimensions and/or shape of the female depressions 26 may be arranged to create a cavity equal to a thickness of the dough section 20 as best illustrated in figure 4b. As further illustrated in figure 4a, the first

indication surface 30 may be formed on a ring portion 62 protruding from a second side wall 64 of the male portion 28.

5 The first indication surface 30 is, in this example, provided by a continuous projection in the form of the ring portion 62. Alternatively, the indication surface 30 may be provided by a discontinuous projection or a plurality of projections as for example shown by the semispherical aligned projections 66 in figure 8.

As illustrated in figure 6, the arrangement 10 may be provided in the form of a tart kit 72 that includes a first package 74 that has dough mixture for making a dough blank; a cutter 16 for cutting the dough blank  
10 into dough sections, a molded pan 22 that includes at least one female depression 26 and a male portion 28. The male portion 28 has a first indication surface 30 to provide a fill mark 34 on a dough section when the male portion 28 forces the dough section into a corresponding female depression. There may also be provided in the tart kit 72 a second package 76 that has a filling mixture that is to be placed in the formed dough section and an instructional description and method 80 to use the tart kit 72.

15

An alternative tart kit 72 is illustrated at 72 in figure 7. In this case, the kit includes a cutter 16 for cutting a dough blank into dough sections, a molded pan 22 that has at least one female depression 26, a male portion 28 that has a first indication surface 30 to provide a fill mark on a dough section when the male portion forces the dough section into a female depression; and an instructional description and method 80  
20 to use the tart kit, but does not include the first and second packages 74, 76.

In yet another example, the kit (not shown), may be provided with a set of different sized male portions each having an indication surface to provide a fill mark on different sized dough sections. As well the molded pan may have different sized female depression within a single pan or several different molded  
25 pans each having different sized female depressions.

The arrangement 10, in this case as part of kit 72, may be used as follows, to prepare one or more tarts, such as butter tarts. The baker first prepares a dough blank or dough sheet from the first package 74. The

baker then cuts the dough blank into dough sections using the cutter 16. The baker may then prepare the molded pan so that one or more female depressions as required are able to receive a corresponding dough section, such as by the use of butter or other nonstick materials and the like. The baker then prepares the male portion and presses each dough section into a corresponding female depression. The pressing of the dough section into a corresponding female depression should be sufficient to cause the first indication surface to provide a fill mark 34 on the dough section. The baker may then prepare the filling from the second package, if provided, to be placed in the formed dough section. The baker then adds the filling into the pastry shell to the fill line 34. The so-formed pastry item may be finished as desired, which may include placing a dough cover on the filled pastry shell, icing or the like and then baked or otherwise cooked, as desired.

If desired, the kit 72 may also be used without the packages 74, 76 but instead with a pre-made dough blank for that matter a series of pre-made dough sections, which may for example be provided in frozen package form.

Figure 3 shows a simplified example of the fill line 34 formed in an inner face of the pastry shell. What figure 3 does not show are the folds and other formations or discontinuities that are sometimes necessary in order to place the relatively large dough section in the depression. For example, the dough section may have a diameter of about 4 inches to about 7 inches while the female depression may have an opening ranging from about 3 inches to about 5 inches and a depth ranging from about 1.5 inches to about 2.5 inches. Thus it will be understood that the fill line may not necessary present itself in a consistent matter around the entire circumference of the pastry shell. Rather, the fill line may be present more prominently on one side of the pastry shell than an opposite side.

Furthermore, there may be examples where the ring portion may not fully circumscribe the side face of the male portion. Rather, the ring portion may simply be provided with an included angle of 180 degrees of the full 360 degrees of the male portion circumference, or 90 degrees or for that matter, an included angle from 10 degrees to 350 degrees, for instance. What is important is that the fill line present, to the naked eye, a

level at which pastry filling should be added to provide sufficient free volume in the pastry shell above the line to permit the filling to expand as need be during the baking process without overflowing onto the pan. This is particularly important for custard-like fillings which include butter tart fillings. Such fillings include varying proportions of egg which results in a relatively greater rate of expansion than non custard -  
5 like fillings.

Thus, the arrangement 10 provides a male portion 28 with an indication surface 30 in order to provide a visual indication of a fill line for a filling material to be added to the so formed pastry shell. The male portion 28 together with the molded pan provides a combination which is beneficial because the male  
10 portion has an outer profile that is matched to the corresponding inner profile of the female portion formed in the molded pan 22 allowing for an improved manual method of forming a pastry shell with a more consistent side wall and bottom wall thickness. Thus, in one embodiment, the arrangement may include a cutter for cutting a dough blank into dough sections; a molded pan having at least one female depression; and a male portion, the male portion having an outer profile including a downwardly outer tapered side  
15 wall and a substantially planar outer bottom wall, the molded pan having an inner profile including a downwardly inner tapered side wall and a substantially planar inner bottom wall, the downwardly tapered outer side wall being complementary to the downwardly tapered inner side wall, the substantially planar outer bottom wall being complementary with the substantially planar inner bottom wall, in order to form a cavity between the male portion and the female portion for molding a pastry shell therein.

20 While the male portion has been described with reference to molded pan and an arrangement for forming a dough article, the male portion may, if desired, be provided separately, provided the purchaser otherwise has access to a suitably dimensioned molded pan or other structure providing a complementary female portion.

25 While the present invention has been described for what are presently considered the preferred embodiments, the invention is not so limited. To the contrary, the invention is intended to cover various modifications and equivalent arrangements included within the spirit and scope of the appended claims.

The scope of the following claims is to be accorded the broadest interpretation so as to encompass all such modifications and equivalent structures and functions.

## CLAIMS:

1. An arrangement to form a dough article comprising a cutter for cutting a dough blank into dough sections; a molded plate having at least one female depression; and a male portion, the male portion including a lateral projection with a first indication surface, the male portion being dimensioned to fit within the female depression, the male portion including a lateral projection which is dimensioned relative to the female depression to provide a fill mark on a dough section when the male portion forces the dough section into the female depression.  
5
2. An arrangement as defined in claim 1, the cutter including a sharp edged circular walled formation having an inner diameter to provide the dough section with an outer boundary to be located near a top surface of the at least one female depression.  
10
3. An arrangement as defined in claim 1, the at least one female depression including a plurality of female depressions being spaced in a repeating pattern.  
15
4. An arrangement as defined in claim 3, the male portion being a truncated cone.
5. An arrangement as defined in claim 4, the projection including a ring portion at least partially circumscribing the side wall of the male portion.  
20
6. An arrangement as defined in claim 5, the projection being continuous.
7. An arrangement as defined in claim 5, the projection being discontinuous.  
25
8. An arrangement as defined in claim 4, the dough section having a thickness, the male portion having an outer diameter that is smaller than an inner diameter of the at least one female depression to create a cavity equal to the thickness of the dough section.

9. A method of forming a dough article comprising:

- providing a cutter for cutting a dough blank into dough sections;
- providing a molded plate having at least one female depression; and
- providing a male portion, the male portion having a first indication surface to provide a fill mark on a dough section when the male portion forces the dough section into a female depression.

10. A method of forming a dough article comprising:

- preparing a dough blank,
- cutting the dough blank into dough sections using a cutter;
- preparing a molded plate having at least one female depression to receive a corresponding a dough section;
- preparing a male portion with a first indication surface projecting laterally therefrom; and
- pressing a dough section into a female depression with the male portion, sufficient to cause the first indication surface to provide a fill mark on the dough section.

11. A method of forming a dough article comprising:

- preparing a dough blank,
- cutting the dough blank into dough sections using a cutter;
- preparing a molded plate having at least one female depression to receive a corresponding dough section;
- preparing a male portion with a first indication surface projecting laterally therefrom;
- pressing a dough section into a female depression with the male portion, sufficient to cause the first indication surface to provide a fill mark on the dough section;
- preparing a flavoured mixture;
- filling the flavoured mixture into the dough section to the fill mark.

12. A tart kit comprising a first package having dough mixture for making a dough blank; a cutter for cutting the dough blank into dough sections; a molded plate having at least one female depression; a male portion, the male portion having a first indication surface to provide a fill mark on a dough section when the male portion forces the dough section into a female depression; a second package having a filling mixture for a formed dough section and an instructional description and method to use the tart kit.
13. A tart kit comprising a cutter for cutting a dough blank into dough sections; a molded plate having at least one female depression; a male portion, the male portion having a first indication surface to provide a fill mark on a dough section when the male portion forces the dough section into a female depression; and an instructional description and method to use the tart kit.
14. An arrangement to form a dough article comprising a molded plate having at least one female depression, the molded plate having an upper periphery, the arrangement further comprising a male portion, the male portion having an outer profile including a downwardly outer tapered side wall and a substantially planar outer bottom wall, the molded plate having an inner profile including a downwardly inner tapered side wall and a substantially planar inner bottom wall, the downwardly tapered outer side wall being complementary to the downwardly tapered inner side wall, the substantially planar outer bottom wall being complementary with the substantially planar inner bottom wall, in order to form a cavity between the male portion and the female portion for molding a pastry shell therein, the male portion further comprising at least one projection extending outwardly from the downwardly outer side wall and in a central region thereof, the male portion and female portions region being arranged so that the at least one projection is operable to form a fill mark on an inner side surface of the pastry shell.

25

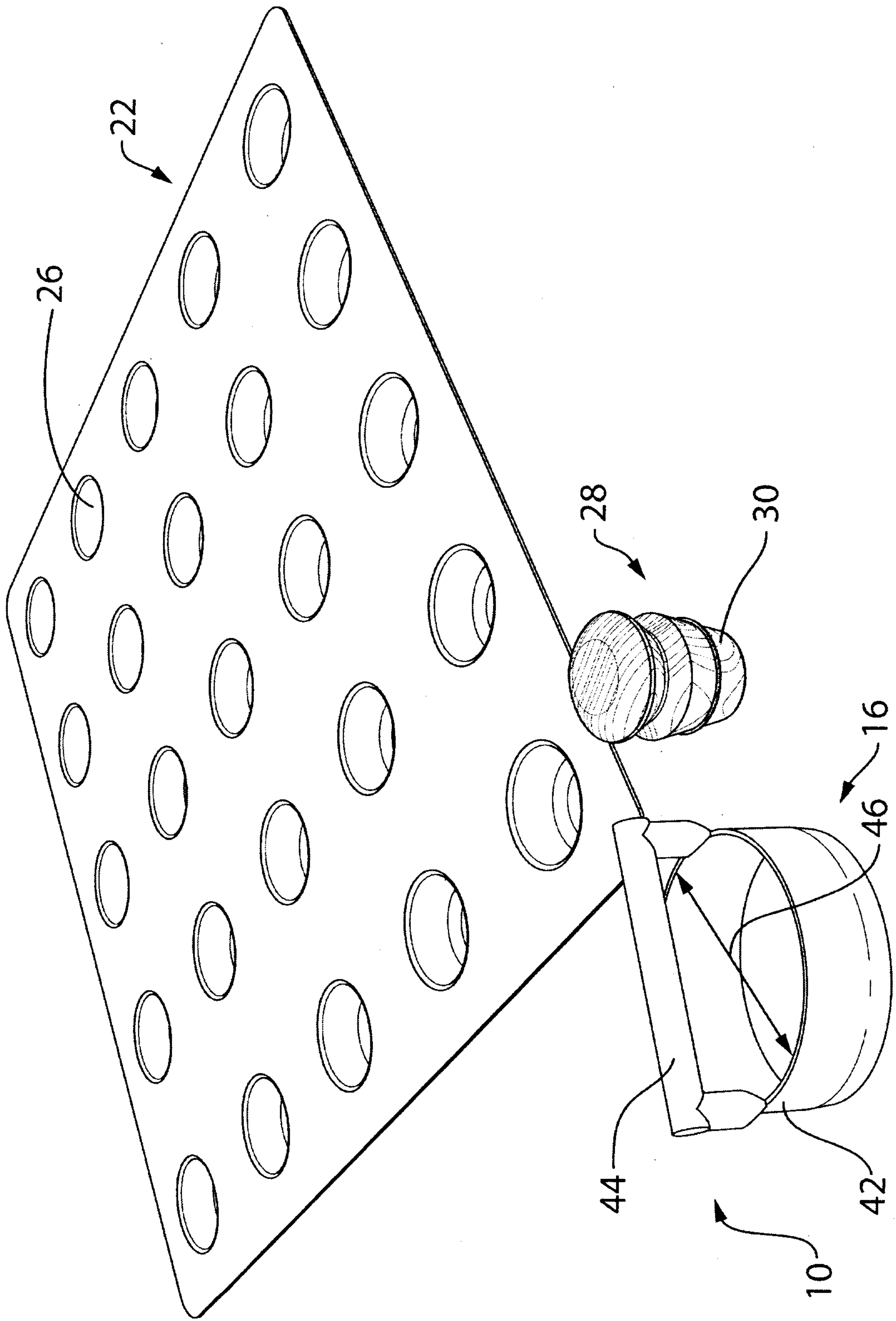

FIG. 1

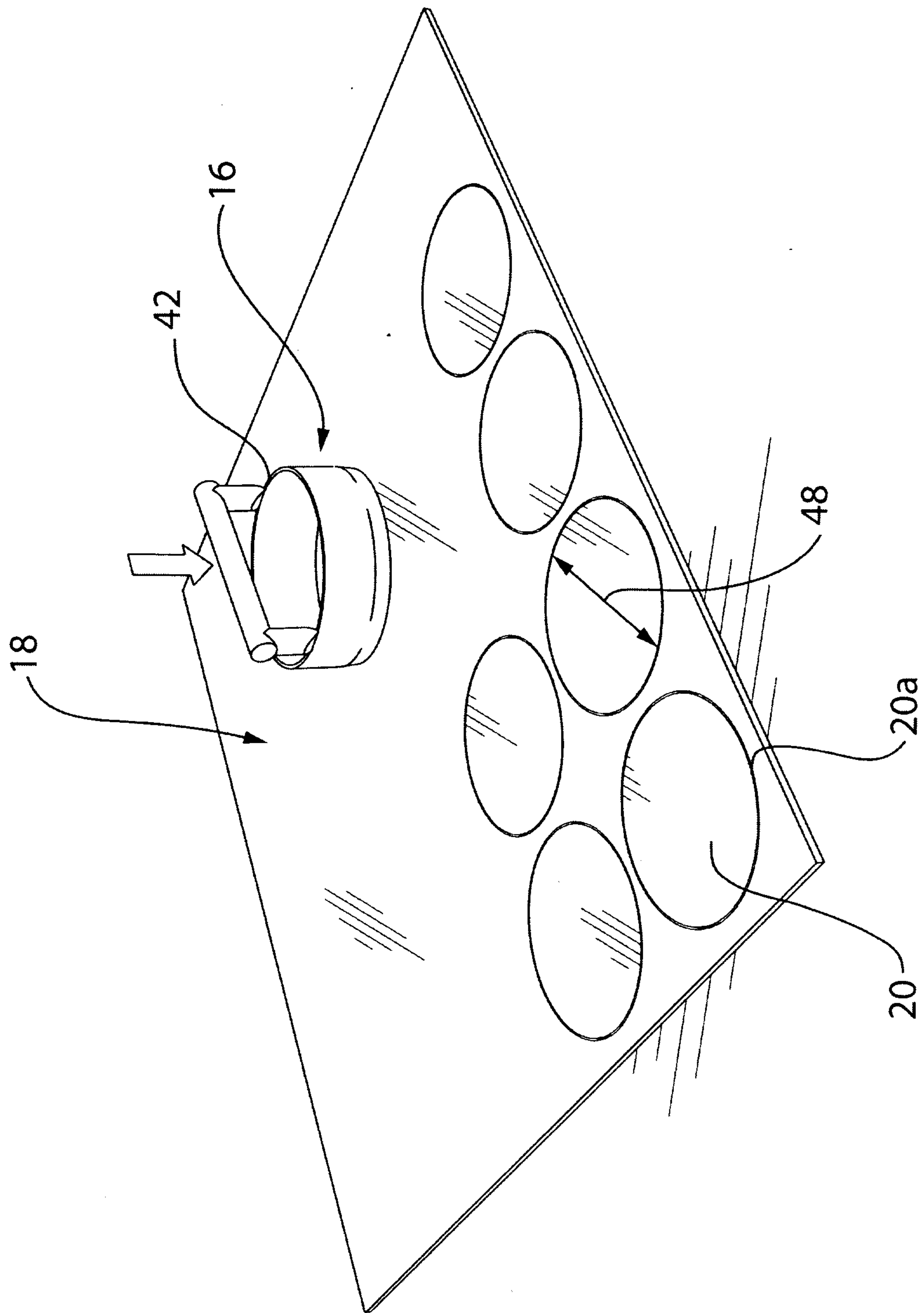

FIG. 2

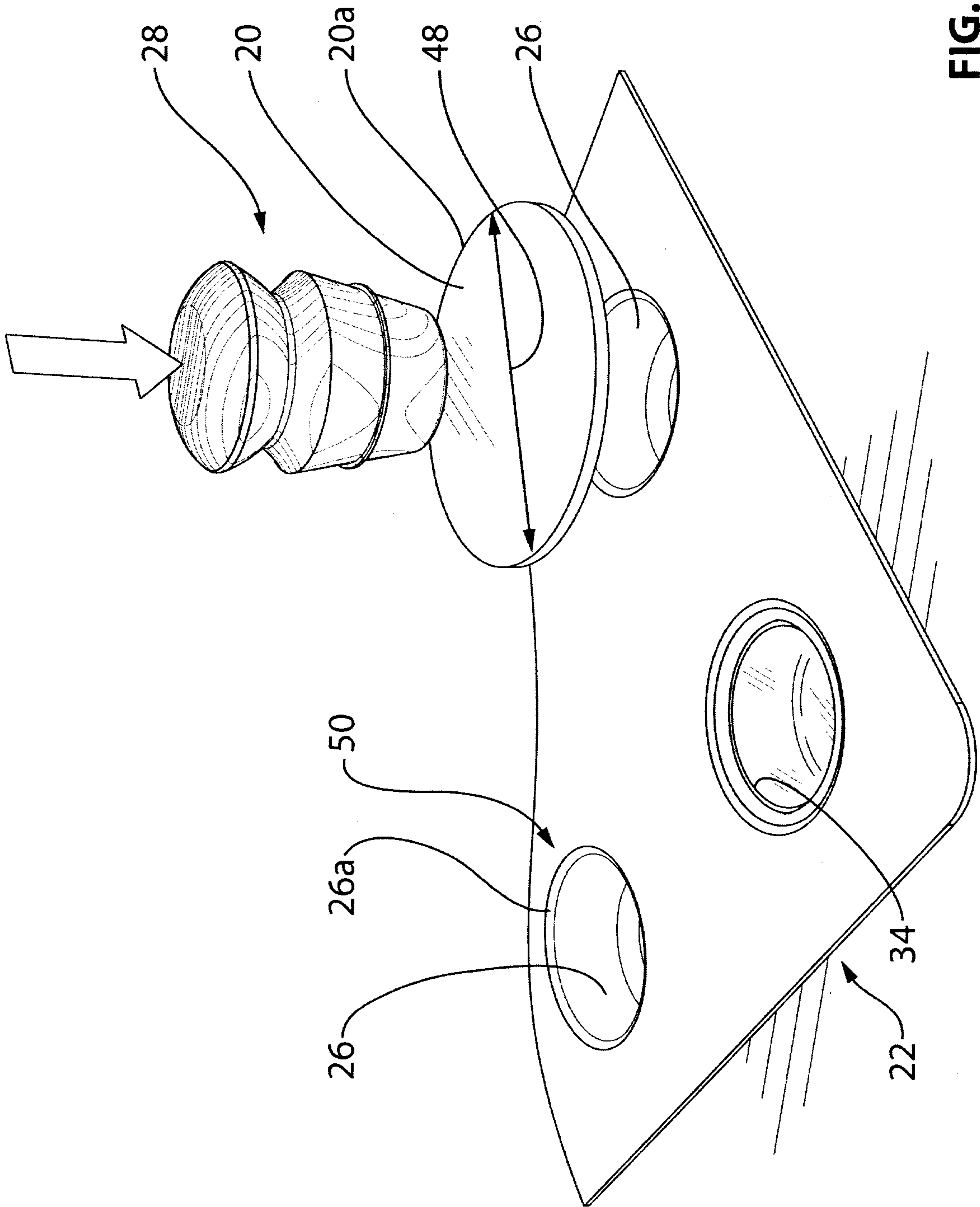

FIG. 3

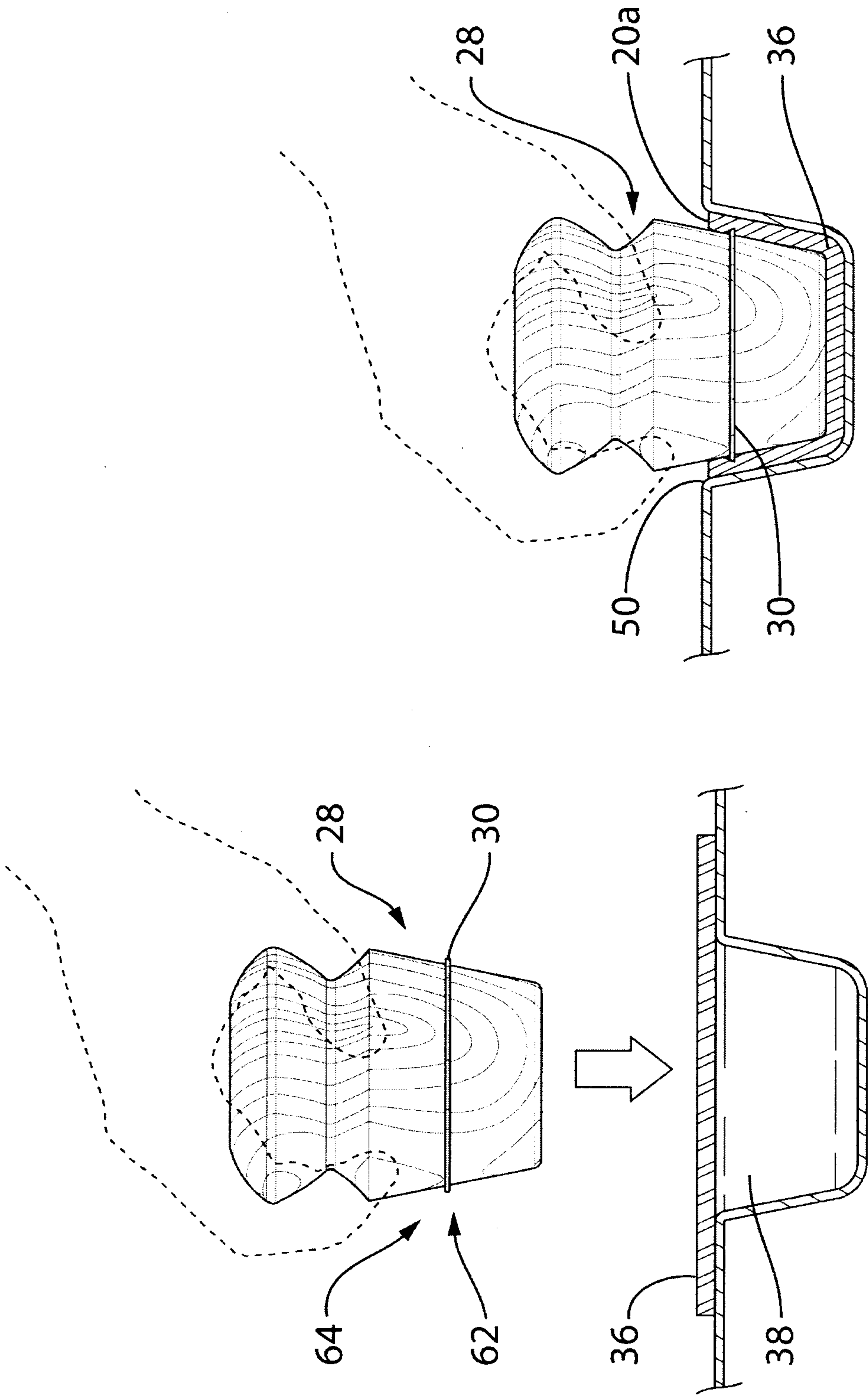

FIG. 4a

FIG. 4b

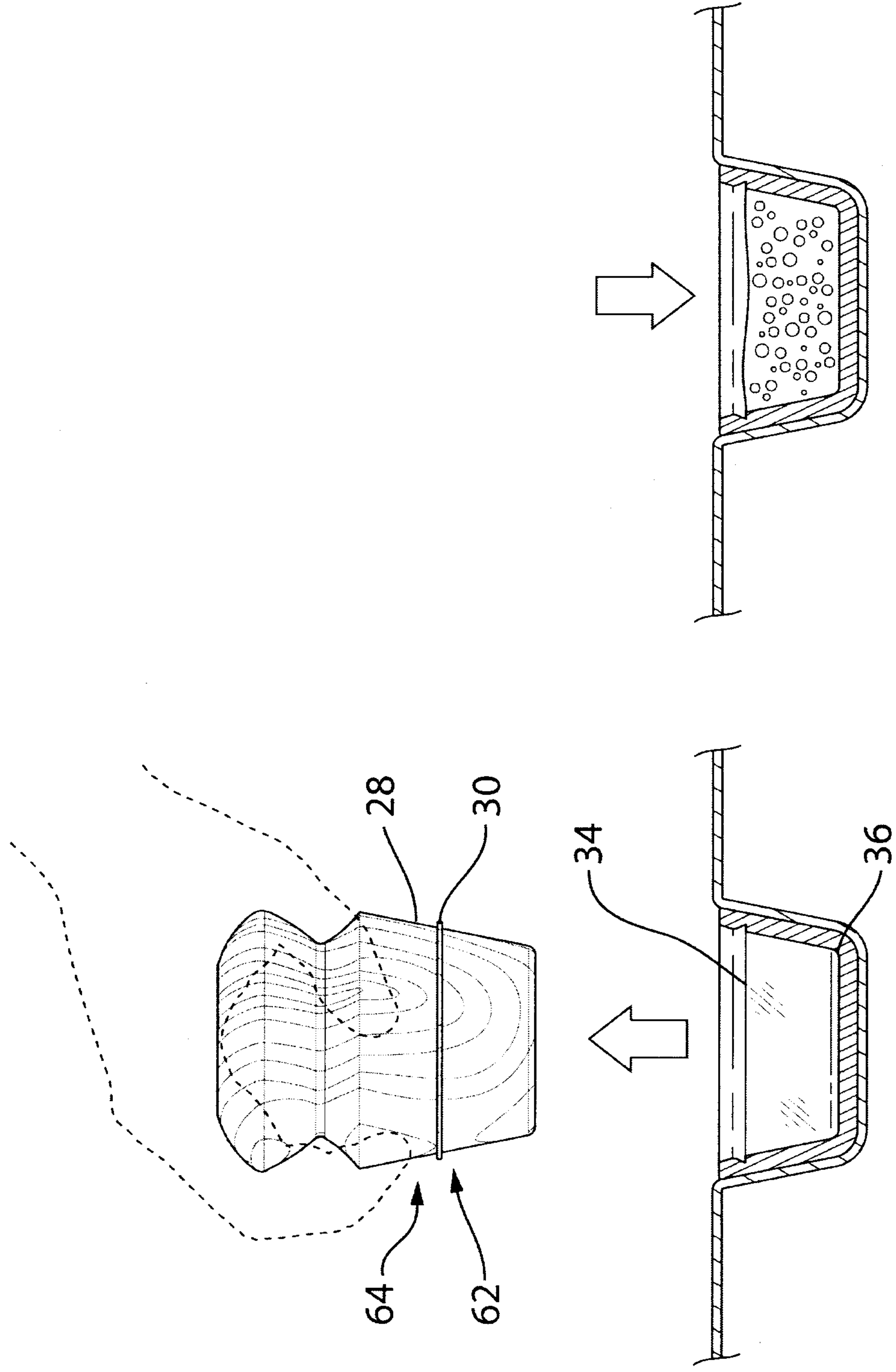

FIG. 5b

FIG. 5a

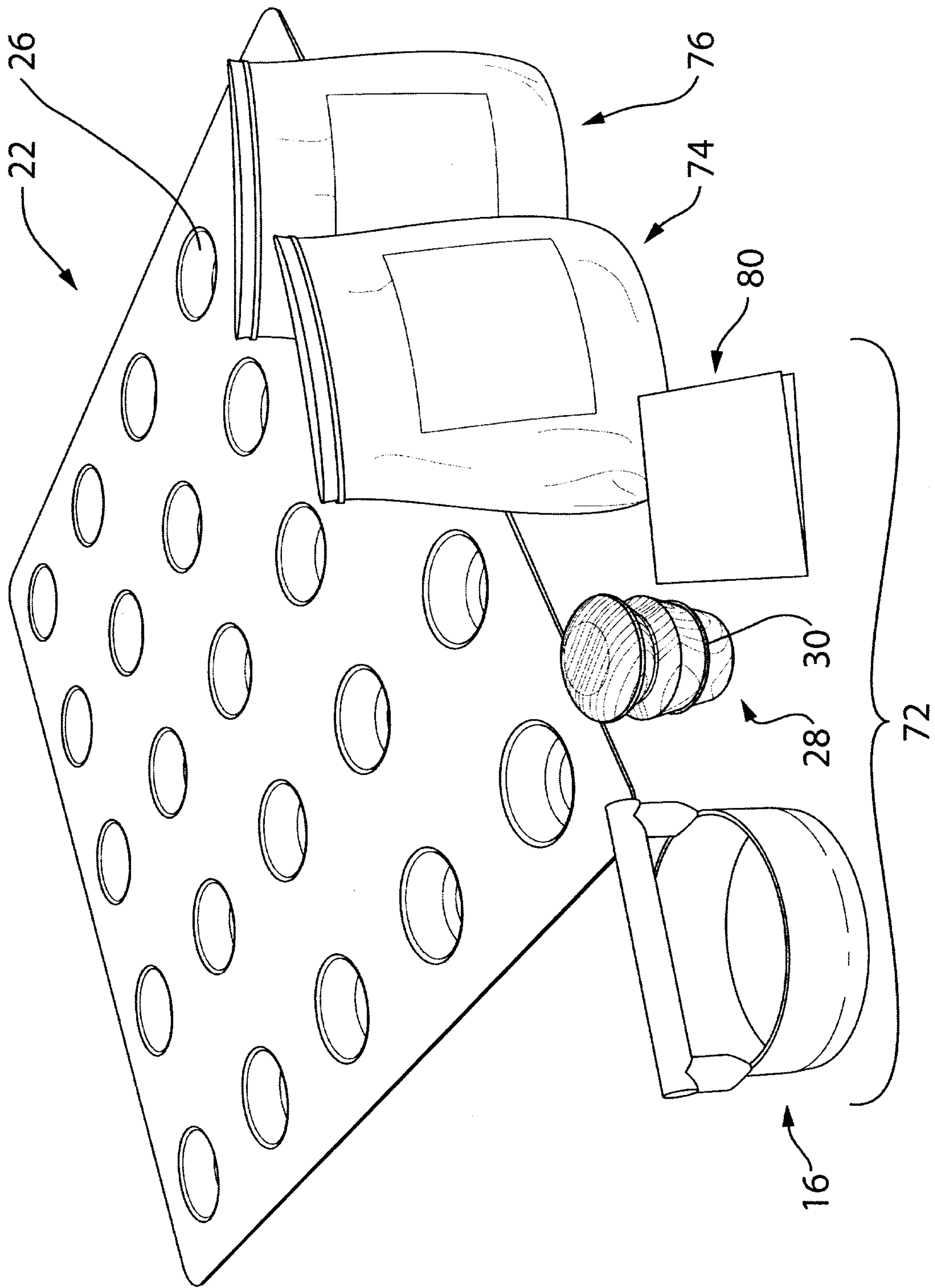

FIG. 6

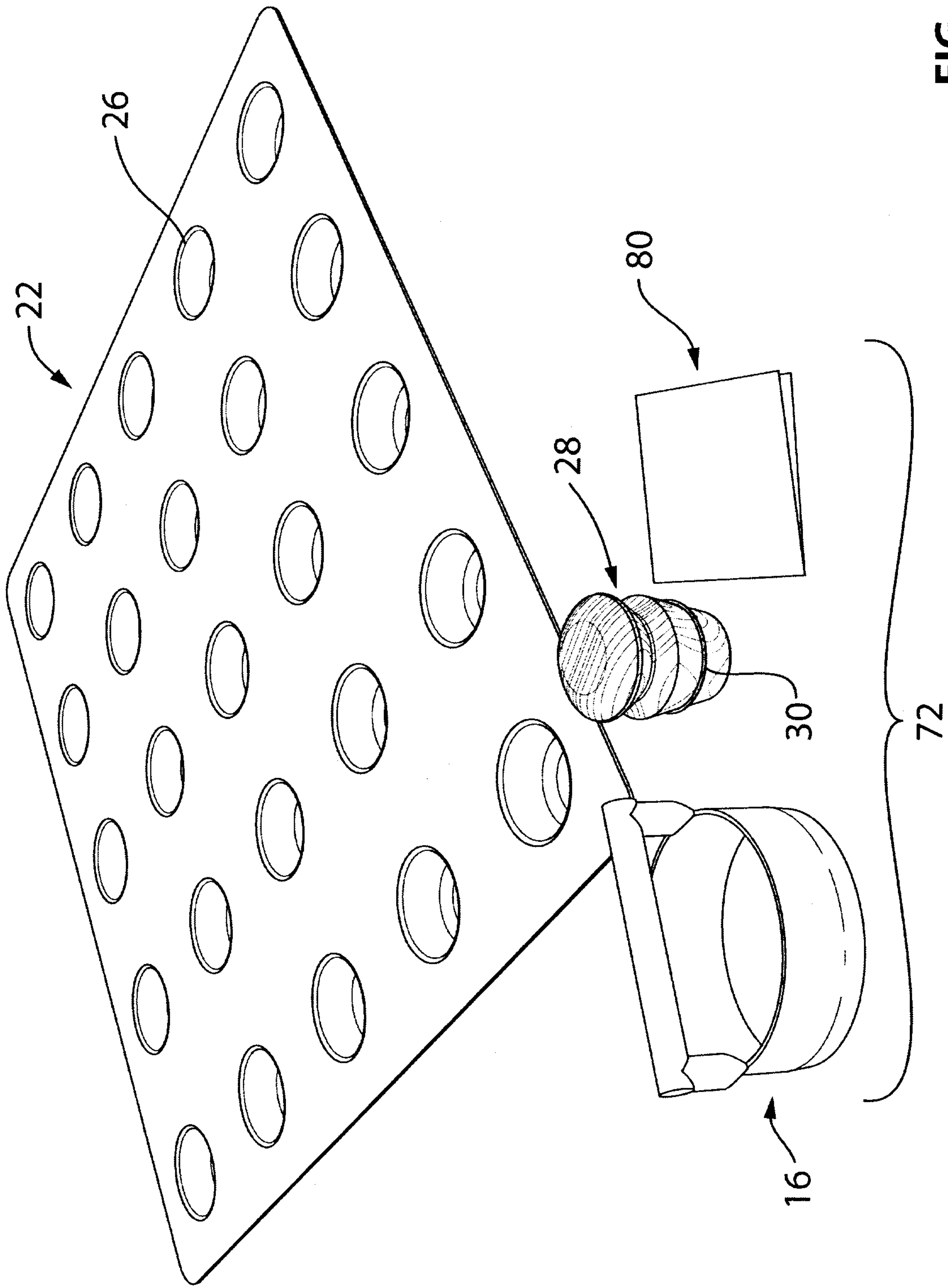

FIG. 7

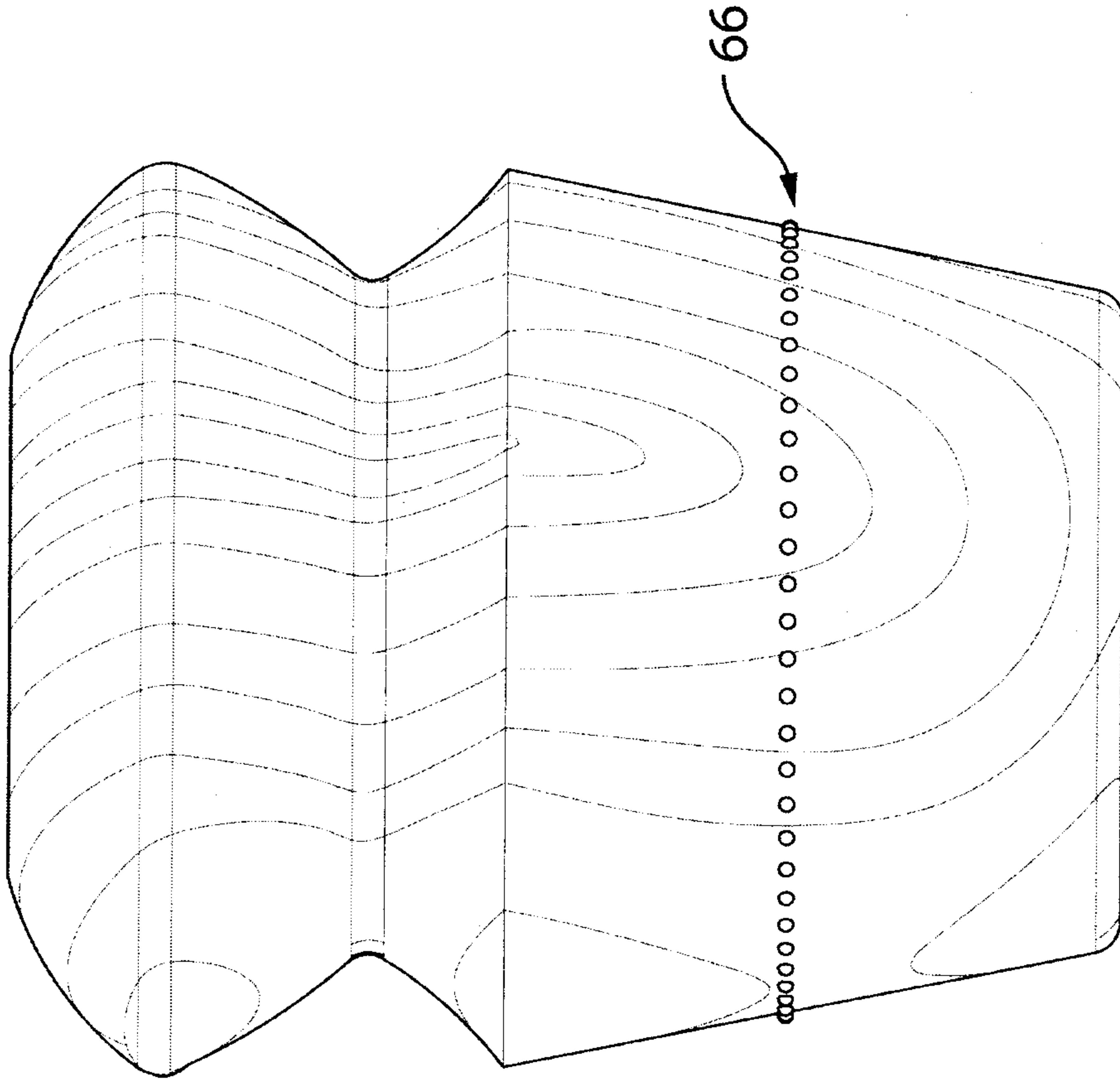

FIG. 8

