



INTERNATIONAL APPLICATION PUBLISHED UNDER THE PATENT COOPERATION TREATY (PCT)

| | | |
|--|-----------|---|
| <p>(51) International Patent Classification ⁴ : B67D 5/54, 5/62, 5/64</p> | <p>A1</p> | <p>(11) International Publication Number: WO 87/ 05283 (43) International Publication Date: 11 September 1987 (11.09.87)</p> |
| <p>(21) International Application Number: PCT/US87/00506 (22) International Filing Date: 9 March 1987 (09.03.87) (31) Priority Application Number: 838,211 (32) Priority Date: 10 March 1986 (10.03.86) (33) Priority Country: US (71)(72) Applicant and Inventor: STEIN, Andrew, M. [US/US]; 188 Harbor Lane, Massapequa Park, NY 11701 (US). (74) Agent: MARSHALL, Jonathan, A.; Pennie & Edmonds, 1155 Avenue of the Americas, New York, NY 10036 (US). (81) Designated States: AT (European patent), AU, BE (European patent), CH (European patent), DE (European patent), FR (European patent), GB (European patent), IT (European patent), JP, LU (European patent), NL (European patent),</p> | | <p>SE (European patent). Published <i>With international search report.</i></p> |

(54) Title: APPARATUS AND METHOD FOR DISPENSING WARM LIQUID FOODS

(57) Abstract

An apparatus for dispensing warm liquid food which comprises an insulating housing (16), heating coils (24) for providing heat inside the housing, a supply tank (22) for holding a predetermined amount of liquid food, the supply tank located inside the housing, flexible tubing (28) for directing the heated supply of liquid food to a control valve (34) and further to a dispensing nozzle (30), the control valve opening to allow a predetermined amount of liquid food from the pressurized tank to the dispensing nozzle to discharge the predetermined amount of food. Also, a method for dispensing warm liquid food by utilizing the apparatus.

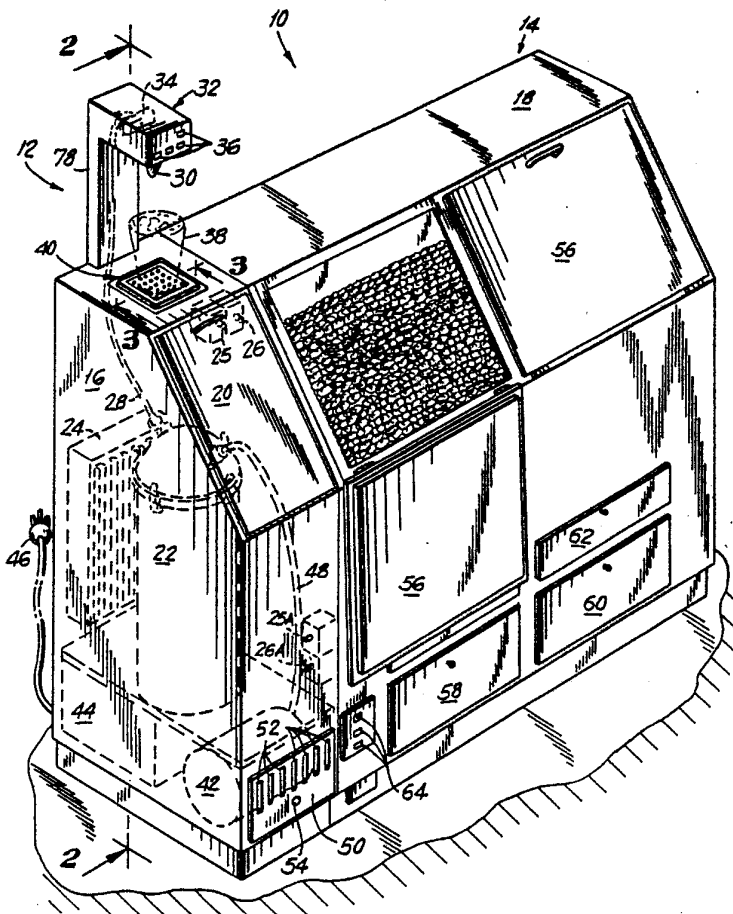

FOR THE PURPOSES OF INFORMATION ONLY

Codes used to identify States party to the PCT on the front pages of pamphlets publishing international applications under the PCT.

| | | | | | |
|-----------|------------------------------|-----------|--|-----------|--------------------------|
| AT | Austria | FR | France | ML | Mali |
| AU | Australia | GA | Gabon | MR | Mauritania |
| BB | Barbados | GB | United Kingdom | MW | Malawi |
| BE | Belgium | HU | Hungary | NL | Netherlands |
| BG | Bulgaria | IT | Italy | NO | Norway |
| BJ | Benin | JP | Japan | RO | Romania |
| BR | Brazil | KP | Democratic People's Republic of Korea | SD | Sudan |
| CF | Central African Republic | KR | Republic of Korea | SE | Sweden |
| CG | Congo | LI | Liechtenstein | SN | Senegal |
| CH | Switzerland | LK | Sri Lanka | SU | Soviet Union |
| CM | Cameroon | LU | Luxembourg | TD | Chad |
| DE | Germany, Federal Republic of | MC | Monaco | TG | Togo |
| DK | Denmark | MG | Madagascar | US | United States of America |
| FI | Finland | | | | |

APPARATUS AND METHOD FOR DISPENSING WARM LIQUID FOODSTechnical Field

5 The invention relates to a novel apparatus for dispensing warm liquid foods, such as butter, cheese, oil or the like, along with a method for dispensing such foods.

Background Art

10

 In the fast food industry, and the theatre industry, concession facilities are designed for the fast service of customers. It is also desirable to provide food portions of substantially the same sizes or quantities repeatedly and rapidly, since a high volume of customers must be served. Numerous apparatus and methods exist for dispensing food products, such as beverages, meats (i.e., hamburgers and the like) as well as for soup, coffee, or other hot foods. Such systems are generally reliable and have been extensively used throughout the United States and the world.

20

 To applicant's knowledge, however, equipment and methods for dispensing warm liquid foods such as melted butter, melted cheese, warm oil and the like, are either not available or the present units are not capable of achieving the rapid dispensing of controlled portions and large volume capacity of the warm food product in a repeatable and reproducible manner. Thus, the applicant's invention provides one such apparatus and method for resolving this need of the industry.

30

35

Summary of the Invention

The invention relates to a method for dispensing heated liquid food which comprises placing a supply of liquid food in holding means, providing heat into the housing means so as to heat the liquid supply of food to a predetermined temperature, directing the heated liquid food to dispenser means, and dispensing predetermined amounts of the heated liquid food as desired. The method may also include automatically controlling the amount of liquid food to be dispensed.

Preferably, the directing step comprises pumping the heated liquid food to the dispenser means, or pressurizing the holding means so as to force the heated liquid food to the dispensing means. The dispensing step comprises spraying the heated liquid food in a predetermined manner.

In a preferred arrangement, the method includes providing means for holding a predetermined amount of solid food product adjacent the heated liquid food dispenser means. Also, the means for holding solid food may be heated. Thus, a preferred solid food product is popcorn and a preferred liquid food is butter, oil or butter substitute. Also, the solid food product may be chips or crackers and the liquid food may be melted cheese.

The invention also relates to an apparatus for dispensing warm liquid food which comprises housing means, means for providing heat inside the housing means, means for holding a predetermined supply of liquid food, the holding means located in the housing means, means for directing the heated liquid food to dispensing means, means for controlling

the dispensing means to dispense a predetermined amount of heated liquid food, and means for dispensing said heated liquid supply of food.

5 Preferably, the housing means is insulated. Also, the means for heating the housing is located inside the housing, and comprises a heating coil and thermostat pre-set or adjustable. The means for directing the heated supply of food comprises either conduit means and pumping means, or the
10 supply means is pressurized so as to force the heated liquid food through the conduit means to the dispensing means. A preferred means for controlling the dispensing means is a solenoid valve or pumping means.

15 In one embodiment, the apparatus further includes means for holding a predetermined amount of solid food product adjacent to the dispensing means, the holding means preferably being heated. The preferred liquid and solid foods are as described above.

20 Brief Description of the Drawing Figures

 The nature, advantages, and various other additional features of the invention will appear more fully upon consideration of the illustrative embodiments now to be
25 described in detail in connection with the accompanying drawing figures, wherein:

 FIG. 1 is perspective view of a warm butter dispensing apparatus according to the invention, shown in combination with a popcorn warming apparatus;

30 FIG. 2 is a cross-sectional view of the warm butter dispensing apparatus of FIG. 1 taken along lines 2--2;

 FIG. 3 is a cross-sectional view of a spill plate for the warm butter dispensing apparatus of FIG. 1, taken
35 along lines 3--3;

FIG. 4 is a cross-sectional view of the warm butter dispensing apparatus of FIG. 1, taken along lines 4--4 of FIG. 2;

5 FIG. 5 is a partial cross-sectional view for an alternate embodiment of the warm butter dispensing apparatus of FIG. 2;

FIG. 6 is a schematic illustration of a wiring diagram for accurately controlling and repeatedly dispensing warm butter from the apparatus of FIG. 1; and

10 FIG. 7 is a detail of a preferred spray nozzle for use in dispensing the warm liquid food product.

Detailed Description of the Invention

15 Referring initially to FIG. 1, there is illustrated a combination warm butter dispensing/popcorn warming apparatus 10 for use by the concession industry and primarily for use in movie theaters and the like. The inventive butter dispensing apparatus 12 is located at one end of the popcorn warming apparatus 14. For convenience of assembly, the
20 butter dispensing apparatus 12 and popcorn warming apparatus 14 can share a common wall therebetween.

The butter dispensing apparatus 12 basically
25 includes a housing 16 which includes an upper portion and a lower portion. This housing 16 is dimensioned and configured to match the shape of the housing 18 of the popcorn warming apparatus 14. Access is gained into the upper portion of housing 16 through door 20. The upper portion of housing 16 includes heating coil and thermostat pre-set or adjustable 24
30 for warming the compartment. Thus, when a sealed supply of butter 22 is placed in the upper compartment, the heating coil provides heat to warm and liquify the butter. Due to

the provision of heat in this portion of the housing 16, it is preferable to insulate the wall members to conserve such heat and reduce energy costs.

5 At the top of the upper compartment, and/or lower
compartment, thermostats 25A and 26A or thermostats 25 and 26
are provided for controlling the temperature. One
thermostat, e.g. 25, is set at a predetermined minimum value
10 to maintain the temperature of the butter at just above its
solidifying point. This thermostat is on at all times and
maintains the butter in a liquid condition ready for
dispensing. Thermostat 26 is used to raise the temperature
inside the chamber during periods where the demand for the
dispensing of butter is greater, i.e. such as between movie
15 performances and the like. These higher temperatures enable
the butter to be more easily dispensed. The thermostats may
be preset to the appropriate temperatures for the food to be
dispensed. Alternately, the unit can be provided with
adjustable thermostats to allow the operator to select
20 different temperatures for various liquid food products to be
dispensed. This enables the apparatus to be used for
dispensing different types of liquid foods.

The heated butter passes through conduit 28, then
25 through the top of the unit, to dispensing means. This
dispensing means is preferably in the form of a spray nozzle
30. The amount of butter to be dispensed through the spray
nozzle 30 is controlled by electronic circuitry in the
control head 32 of the dispensing apparatus 12. In the
30 embodiment shown, control of the spray nozzle 30 is
accomplished by way of a solenoid valve 34 which is in turn
controlled and actuated by the electronic circuitry. A
preferred solenoid valve is ASCO 8260A31 which is available

from Automatic Switch Company, Florham Park, New Jersey. To operate this valve, the user merely depresses the push buttons 36 on the face of the control head 32.

5 A bucket of popcorn 38 or other solid food product is placed under the spray nozzle 30 on a spill plate/drip pan assembly 40. Then, the operator presses the appropriate button 36 which dispenses the proper amount of butter for the size of popcorn container selected. It is also possible to
10 provide appropriate indentations or guide means on the spill plate/drip pan assembly for proper location of the selected container size. This enables the butter to be dispensed properly upon the popcorn with a minimum of overspray or spillage.

15 As shown in FIG. 1 and 2, the supply of butter 22 is pressurized with a suitable gas from gas supply 42 which, for convenience, is shown as being located in the lower compartment of the apparatus housing 16. Pressure from the
20 gas supply 42 passes through conduit means 48 and into the stainless steel and or plastic butter supply tank 22. Upon an opening of the solenoid valve 34, this gas pressure forces the butter through sparge pipe 72 through the conduit means 28 and solenoid valve 34, and thereafter through spray nozzle 30 onto the popcorn 38. The lower compartment of the housing
25 16 also includes a transformer 44 which transforms the line voltage to a low operating voltage which is used to operate the electric circuitry in the control head 32. The unit can be provided with a standard plug 46 for connection to a
30 standard 110 volt electrical system. Alternately, the dispensing apparatus 12 can be hard-wired into any other electrical system in a manner well known to those skilled in the art.

35

The lower compartment of the butter dispensing apparatus 12 does not have to be insulated since it is not heated. However, a vent plate 50 is provided to vent any heat from the electrical transformer 44 or any pressure loss from gas supply 42 to the atmosphere through vent holes 52. A pilot light 54 is also provided to indicate when the heating coils are in operation and thus generating heat in the upper portion of housing 16. When the temperature in this compartment achieves the temperature set on the thermostats, the heating coil and pilot light each are shut off by the thermostat.

FIG. 1 also illustrates the popcorn warming apparatus 14 which can be used in conjunction with the butter dispensing apparatus 12 of the invention. The upper portion of the apparatus includes similar heating means with the addition of a blower motor and return ducts (chimneys) (not shown) to that used the upper portion of the butter dispensing apparatus and such heating coils are used to keep the popcorn warm (i.e. above ambient temperature). Access to the popcorn is provided through doors 56, which are of a size smaller than the overall dimension of the size of the warming apparatus 14 so that significant amounts of heat are not lost when opening one of the doors 56 to gain access to the popcorn. The electrical components and other necessary components needed for proper operation of these popcorn warming units can be found in the lower portion of the housing, access to which is gained by doors 58, 60 and 62. A series of pilot lights 64 are also provided to enable the operator to determine when the heating coils in the popcorn warming apparatus 14 are operating.

FIG. 2 shows more clearly the arrangement of the components of the butter dispensing apparatus 12 which components are shown in phantom in FIG. 1. Butter supply

tank 22 is provided with quick connect/disconnect couplings 66 and 68 for connecting to conduit 28 and 48, respectively. These conduits 28 and 48 are preferably made of stainless steel aluminum, plastic, or rubber hoses. Other suitable materials for contact with the food to be dispensed can also be used. The butter supply tank 22 is also provided with means such as snap clips 70 which enables the tank to be open for placement of the supply of butter therein. Such supply tanks are standard products which are available in a variety of sizes from Spartanburg Steel Products, Spartanburg, South Carolina. The particular size to be used, i.e. two gallons, three gallons, five gallons, ten gallons, etc., can be determined by the amount of popcorn and butter to be served over a predetermined period. Also, although not shown in the drawings, greater butter storage capacity can be achieved by connecting two or more of these tanks in series.

As shown in phantom in FIG. 2, the sparge pipe 72 is located inside the butter supply tank 22. This pipe 72 is connected to the quick connect/disconnect fitting 66 from which the conduit 28 directs the warm molten butter to the solenoid valve 34 and thereafter to spray nozzle 30. This butter supply tank 22 is designed such that the sparge pipe 72 is located near the bottom of the tank. Thus, pressure from gas supply 42 will pressurize the internal portion of butter supply tank 22, thus forcing the warm liquefied butter through sparge pipe 72, conduit 28, valve 34, and finally to spray nozzle 30. The pressure of the gas supply 22 can vary from about 30 to 130 psi, which is the suggested operating limit for the standard butter supply tank 22. With higher pressure rated butter supply tanks, higher pressures can be used, if desired.

The type of pressurized gas used in this system includes carbon dioxide, nitrogen, compressed air or any other pressurized medium which is compatible with the food products to be dispensed. Although the gas supply 42 is shown located in the lower compartment of the dispensing apparatus for convenience, it can also be a separate supply located in an adjacent fixture or even beneath the floor of the location of the dispensing unit. In a preferred embodiment of the invention, compressed air or nitrogen can be used to direct the liquid butter to the spray nozzle 30.

The temperature to be maintained in compartment 16 would be that above the solidification temperature of the food product, in this case, butter, up to a maximum of approximately 100°C. The 100°C temperature is a reasonable maximum because the unit is primarily designed to handle any food product which is liquid and served at a temperature from average indoor ambient conditions (i.e. about 23°C) up to about 65°C. Obviously, by correct selection of the heating coil and food supply components, higher temperatures or pressures can be safely utilized.

Referring now to FIG. 3, there is illustrated a spill plate/drip pan assembly 40 which is located at the top of the butter dispensing apparatus 12 and upon which the bucket of popcorn is placed for dispensing of the liquefied butter. This assembly 40 includes a perforated spill plate 74, a drip pan 76 and a lined recess portion 78. Any butter drips or spills from the spray nozzle or the outside of the popcorn container pass through the perforations of the plate 74 into the drip pan 76. At a predetermined time, such as the end of a day's operation or any other suitable time, the perforated plate and drip pan 76 can be removed for cleaning and disposal of any spilled butter. To prevent butter leaks on to the cabinet, a lined recess 78 is provided. All three

components, the plate, drip pan 76 and lined recess 78 can be made of stainless steel, aluminum, or plastic for easy cleaning and replacement.

5 Referring now to FIG. 4, there is illustrated in further detail the heating coils 24 and thermostats 25, 26 of the upper portion of housing 16. The butter supply tank 22 is removed so that the heating coils 24 may be easily viewed. The remaining numbered items correspond to those of FIGS. 1,
10 2 and 3.

The control head 32 is shown with four spray control buttons 36. These are connected to the solenoid valve 34 in a manner to allow different time periods for the
15 spray of liquid butter. For example, one button could be used for opening the valve for as long as the button is depressed. This enables a very small or a very large amount of butter to be dispensed due to the discretion of the operator. The other buttons can be connected through
20 appropriate electronic circuitry or microprocessing means to dispense predetermined amounts of butter. For example, one button could be set to a spray time of one second, a second button to a spray time of two seconds and a third button for a spray time of three seconds. The circuitry allows for a
25 degree of variation in the setting of spray times. The longer durations would of course apply to larger containers of popcorn. Those skilled in the art can best determine and set the optimum times for dispensing the appropriate amounts of butter or other liquid food. It is also possible to quite
30 accurately and repeatedly dispense the exact amount of butter for a particular size container through the arrangement described above.

35

FIG. 5 illustrates an alternate embodiment of the present invention. Components which are the same for the other figures carry the same identifying numerals, whereas the new components are identified hereinbelow. In this embodiment, rather than pressurizing the butter supply tank 22, an in-line pump 80 is provided along conduit 28. Furthermore, the electrical circuitry connected to control buttons 36 now are connected to the pump 80 to enable the pump to dispense the appropriate amounts of butter through spray nozzle 30. It is also possible for the pump to be of a submersible type and be located in the liquid supply tank 22. Other pumps can be used, and these can be placed in the heated portion of the housing, under the housing, or in any other appropriate location.

Referring now to FIG. 6 there is illustrated a preferred wiring diagram for the control head 32 which enables the appropriate amounts of butter to be dispensed as described above. By this arrangement, it is also possible to provide very low voltage in the control head 32 for optimum safety to the end user. Thus, one button may be used to dispense butter for as long as it is depressed, while the other three buttons are adjustable to predetermined spray times for the butter. Although standard electronic components are shown in the drawing, it is conceivable that various microprocessing or chip means can be used instead to accomplish the same objectives.

As mentioned above, no line voltage is present in the service head: a voltage of approximately 24 volts is all that is necessary to operate the electronic circuitry. No custom mechanical components are incorporated in this apparatus. Standard components from various manufacturers

are used and these items are usually available "off the shelf". The maximum power usage of the preferred embodiment disclosed is less than 1200 watts from the power service.

5 Although the preferred embodiment of the invention illustrates a warming apparatus containing popcorn in conjunction with a dispensing apparatus which contains a supply of solid and liquid butter, there are numerous alternate combinations of foods which can be used in
10 accordance with the invention. For example, the warming apparatus 14 can contain nacho chips, tortilla chips or corn chips, whereas the supply of liquified food can be cheese. It is also possible to use the dispensing apparatus 12 to dispense melted cheese, heated oil, or similar liquid foods
15 for various purposes wherein an adjacent warming apparatus is not needed. For example, potatoes can be baked in a conventional or microwave oven and then brought to the dispensing apparatus 12 for the addition of melted cheese. This is an example of the use of the dispensing apparatus 12
20 without the warming apparatus 14. Thus, applicant has provided an automatic, increased capacity unit for the accurate and repeated dispensing of warm liquid foods.

 It is also possible for the sides of the control head as well the control head pedestal 78 to be provided
25 with advertisements whether in the form of placards, drawings or the like. If desired, such portions of the unit can be illuminated by appropriate lighting fixtures located within the control head 32 or pedestal 78.

30 Another feature of the invention enables the rapid replacement of empty supply containers 22. As noted above, two or more of such tanks can be used in series. However, for the small user, it is very simple to open door 20 to gain
35 access to the interior of the housing 16 quickly disconnect

the two conduit lines 28, 48 and replace the empty supply tank 22 with a full one. Thus, the food supplies can be prefilled in other locations and quick-coupled in the system as necessary. Similarly, the gas supply 42 can also be rapidly and simply replaced. Furthermore, the butter supply is completely sealed from ambient contamination during operation and is only open for filling and/or cleaning before replacement of another supply of food product.

The system can be permanently installed in a fixed location or made in a mobile manner as desired by the end user. Furthermore, it is possible to clean all the internal components of the system by merely substituting a cleaning solution reservoir for the food supply 22 and running the cleaning solution through the system. Thereafter, the components can be rinsed with a warm water solution to remove any residue of cleaning solution. Thus, the actual butter dispensing apparatus is highly cosmetic in nature and can be located in a public area.

As noted previously, a number of different liquid food products may be utilized in the invention. It may be necessary, however, to interchange the spray nozzle 30 depending on the specific food product to be dispensed. For example, to dispense molten cheese, a larger diameter spray nozzle may be necessary. Also, it is possible for the spray nozzle to be designed to provide a specific spray pattern for dispensing the liquid food upon the solid food product.

Referring now to FIG. 7, there is disclosed a specific spray nozzle 30 which is preferred for the dispensing of molten liquid butter. The tip 90 of the spray nozzle 30 has a central aperture 91 and four radially displaced apertures 92, 93, 94 and 95 for spraying the butter at different angles with respect to the popcorn container.

As one skilled in the art would realize, however, it is possible to develop numerous arrangements for the optimum spray pattern of the liquid food product to be dispensed. This would include dispensing the material in a fine mist spray or, for cheeses or the like, in a glob-like fashion. 5 The end user can best determine the particular spray nozzle necessary for dispensing the food product in the predetermined manner desired.

10 While it is apparent that the invention herein disclosed is well calculated to fulfill the objects above stated, it will be appreciated that numerous modifications and embodiments may be devised by those skilled in the art, and it is intended that the appended claims cover all such 15 modifications and embodiments as fall within the true spirit and scope of the present invention.

20

25

30

35

CLAIMS

What is claimed is:

- 5 1. A method for dispensing heated liquid food
which comprises:
- placing a supply of liquid food in holding
 means located within housing means;
- providing heat into said housing means so as
10 to heat said liquid supply of food to a
predetermined temperature;
- directing said heated liquid food to dispenser
 means; and
- dispensing predetermined amounts of said
15 heated liquid food as desired.
2. The method of claim 1 which further comprises
automatically controlling the amount of liquid food to be
dispersed.
- 20 3. The method of claim 1 wherein said directing
step comprises pumping said heated liquid food to the
dispenser means.
4. The method of claim 1 wherein the directing
25 step comprises pressurizing said holding means so as to force
said heated liquid food to said dispensing means.
5. The method of claim 1 wherein said dispensing
30 step comprises spraying said liquid food in a predetermined
manner.
6. The method of claim 1 which further comprises
35 providing means for holding a predetermined amount of solid
food products adjacent said dispenser means.

7. The method of claim 6 which further comprises heating said means for holding said solid food products.

8. The method of claim 7 wherein the solid food product is popcorn and the liquid food is butter.

9. The method of claim 7 wherein the solid food is chips or crackers and the liquid food is melted cheese.

10. A method for dispensing heated butter for popcorn or the like which comprises:

placing a supply of butter in a sealed container located in housing means;

providing heat into said housing means so as to melt said supply of butter;

directing said melted butter to dispensing means; and

dispensing predetermined amounts of butter as desired upon said popcorn or the like.

11. An apparatus for dispensing warm liquid food which comprises:

housing means;

means for providing heat inside said housing means;

means for holding a predetermined supply of liquid food, said holding means located in said housing means;

means for directing the heated supply of liquid food to dispensing means;

means for controlling the dispensing means to dispense a predetermined amount of food; and

means for dispensing said heated liquid supply of food.

12. The apparatus of claim 11 wherein the housing means is insulated.

5 13. The apparatus of claim 11 wherein the means for heating the housing is located inside the housing.

14. The apparatus of claim 13 wherein the means for heating the housing comprises heating coil means.

10 15. The apparatus of claim 11 wherein the means for directing the heated supply of food comprises conduit means and pumping means.

15 16. The apparatus of claim 11 wherein the means for directing the heated supply of food comprises conduit means and said supply means is pressurized so as to force said heated supply of food through said conduit means to said dispensing means.

20 17. The apparatus of claim 11 wherein the means for controlling the dispensing means is a solenoid valve or pumping means.

25 18. The dispensing apparatus of claim 11 further comprising means for holding a predetermined amount of solid food product adjacent said dispensing means.

19. The apparatus of claim 18 wherein said holding means further comprises means for providing heat therein.

30 20. The method of claim 18 wherein said solid food product is popcorn and said liquid food is butter.

35

21. The apparatus of claim 18 wherein said solid food is crackers or chips and the liquid food comprises melted cheese.

5

10

15

20

25

30

35

FIG. 1

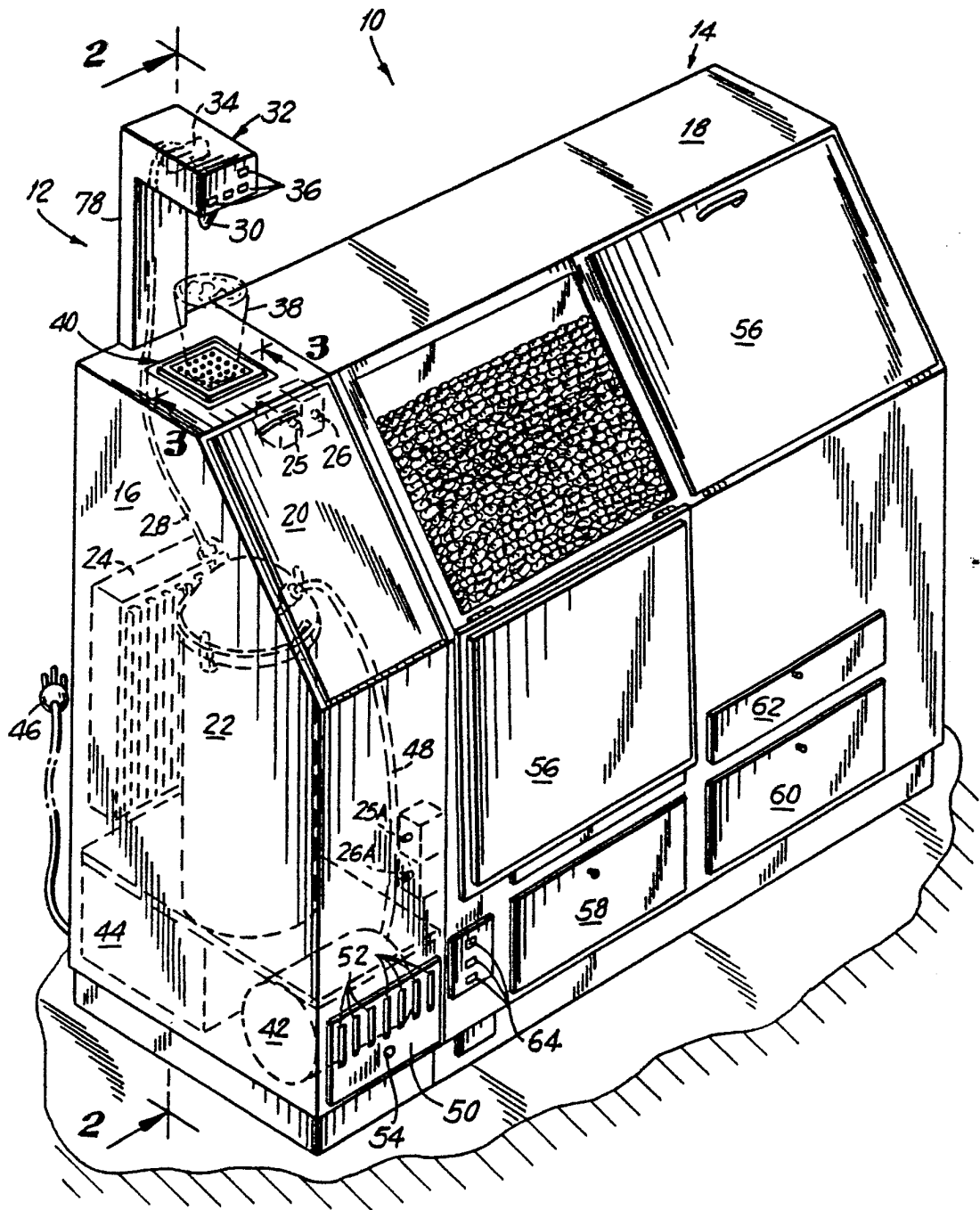

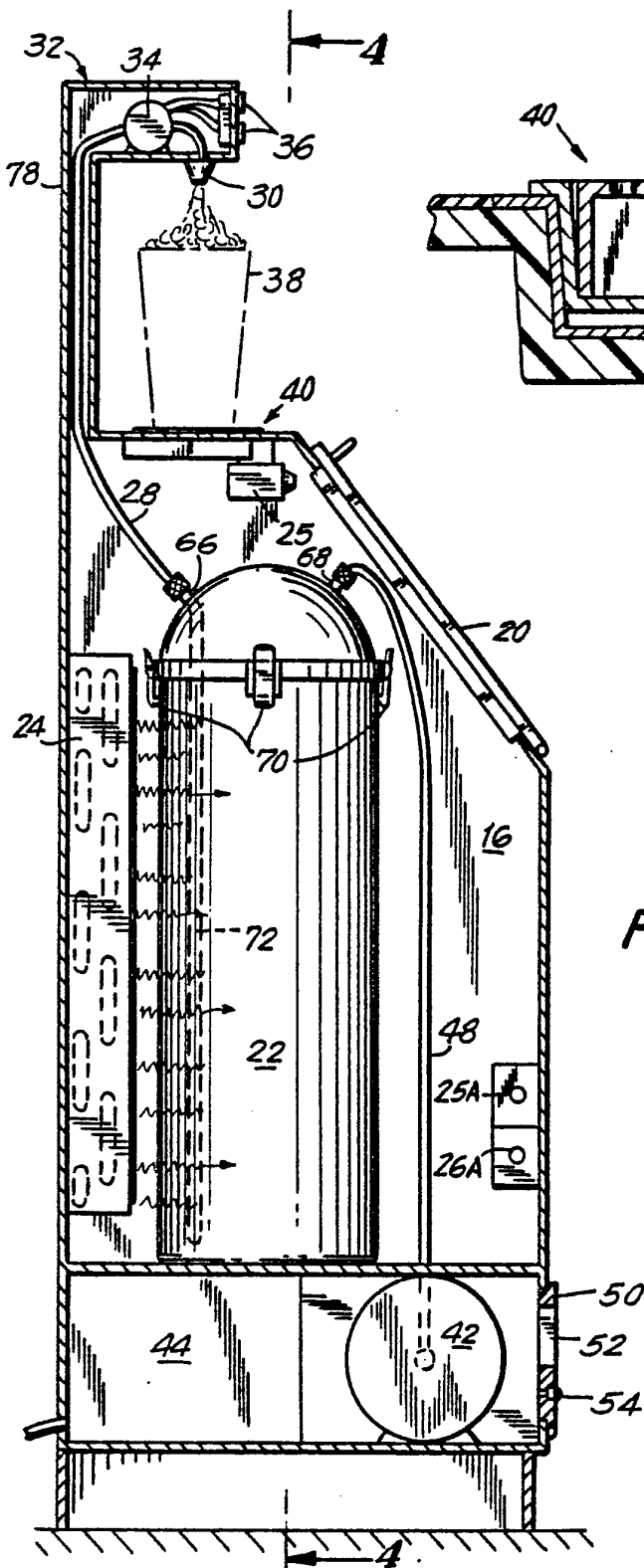

FIG. 2

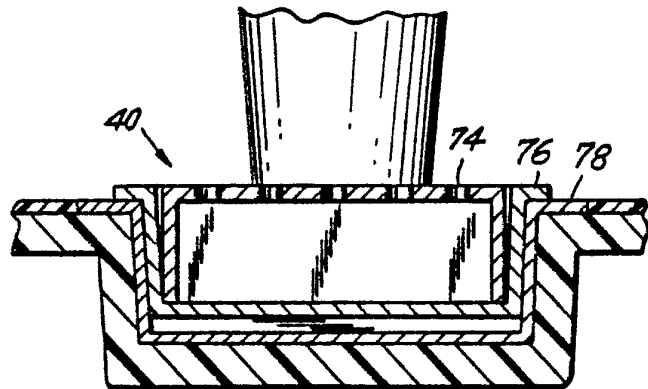

FIG. 3

FIG. 4

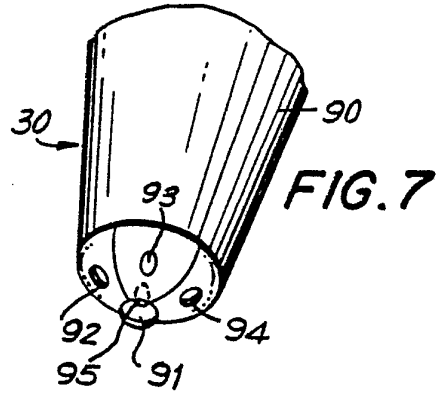
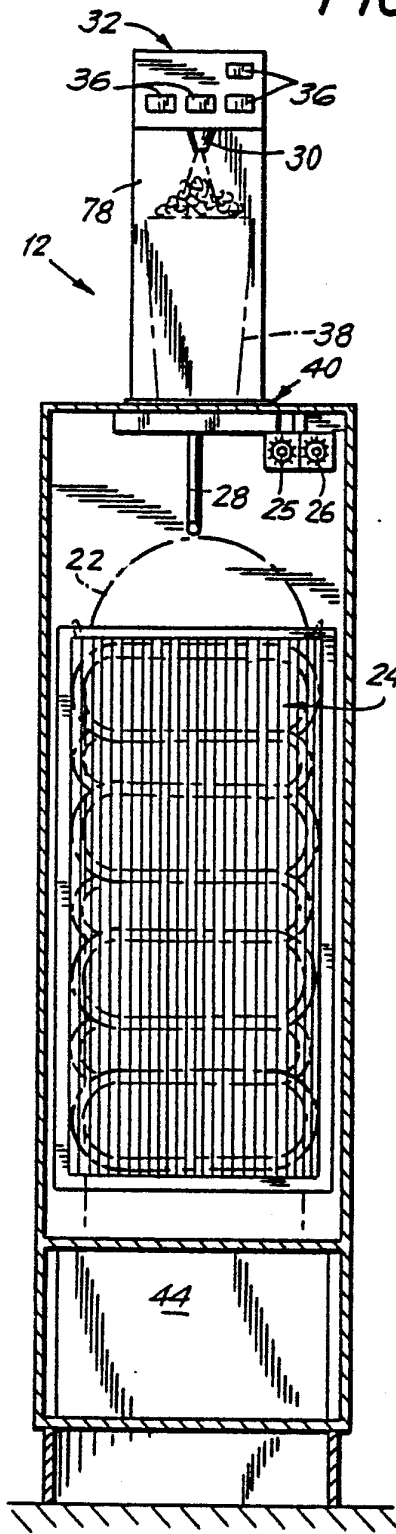
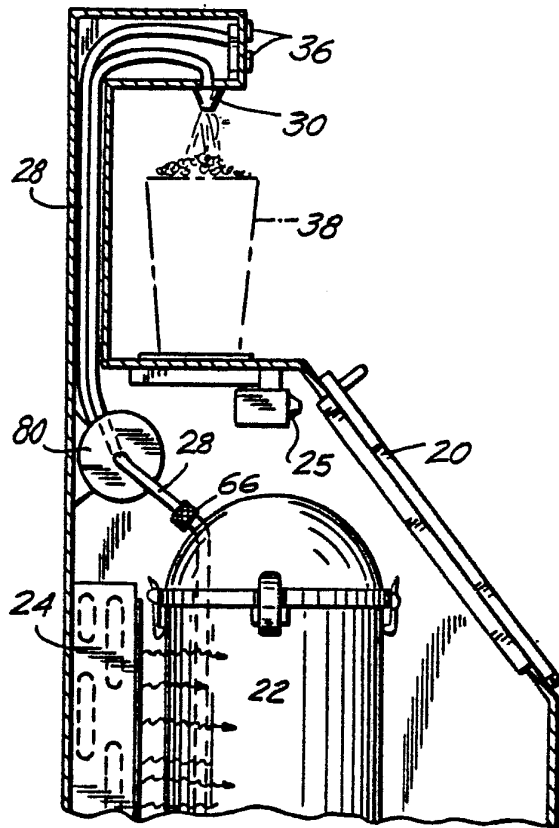

FIG. 5



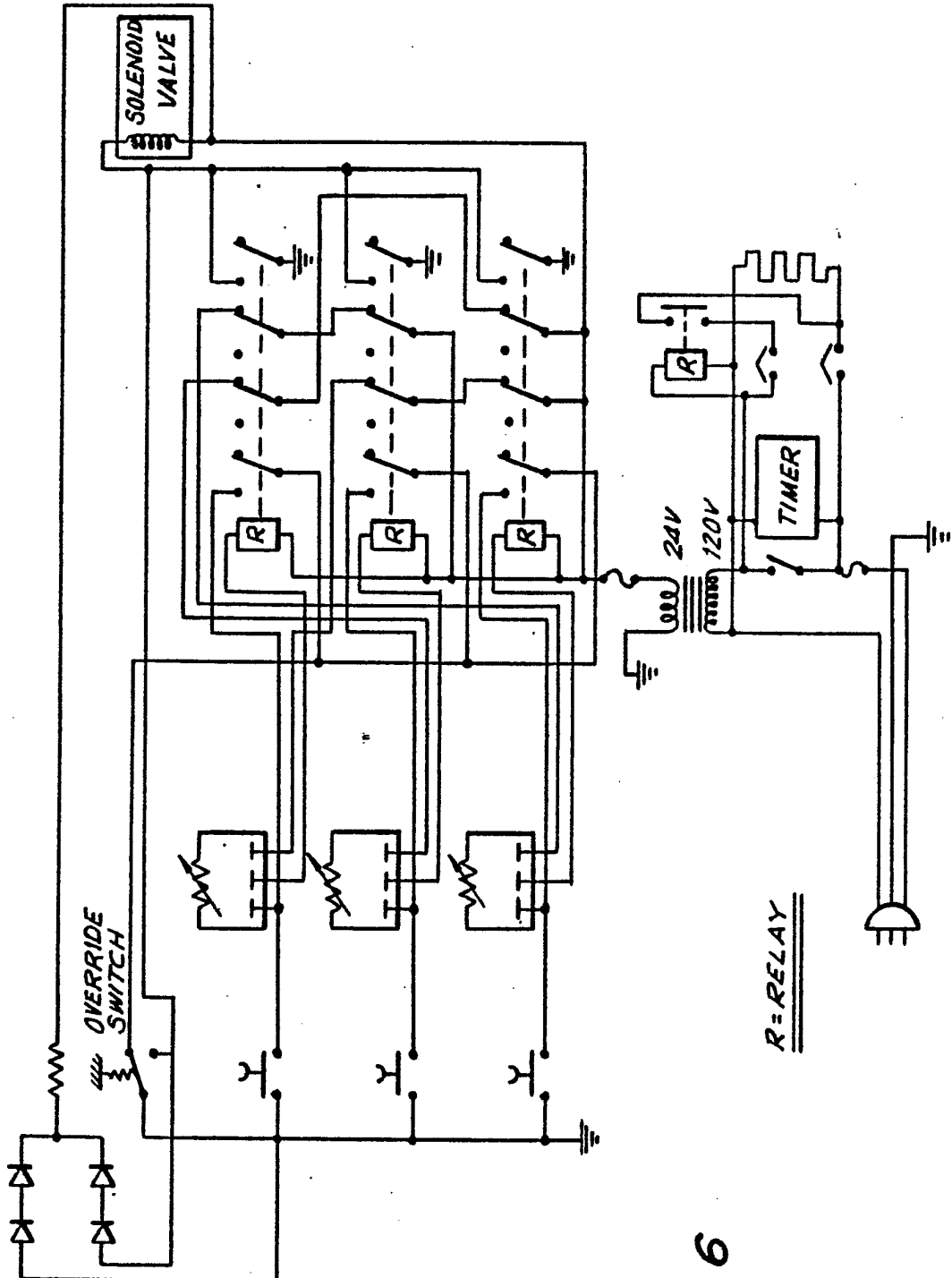

FIG. 6

INTERNATIONAL SEARCH REPORT

International Application No **PCT/US87/00506**

| | | |
|--|--|-------------------------------------|
| I. CLASSIFICATION OF SUBJECT MATTER (if several classification symbols apply, indicate all) ³ | | |
| According to International Patent Classification (IPC) or to both National Classification and IPC | | |
| IPC4: B67D 5/54, 5/62, 5/64 | | |
| US: 222/639, 146.5; 219/214; 312/236 | | |
| II. FIELDS SEARCHED | | |
| Minimum Documentation Searched ⁴ | | |
| Classification System | Classification Symbols | |
| U.S. | 222/639, 146.1, 146.2, 146.5; 219/214, 218, 421 99/323.8, 534; 239/135; 126/343.5; 312/236 | |
| Documentation Searched other than Minimum Documentation to the Extent that such Documents are Included in the Fields Searched ⁵ | | |
| III. DOCUMENTS CONSIDERED TO BE RELEVANT ¹⁴ | | |
| Category * | Citation of Document, ¹⁶ with indication, where appropriate, of the relevant passages ¹⁷ | Relevant to Claim No. ¹⁸ |
| X | US, A, 2,646,189 (Wickesberg) 21 July 1953, see the entire document. | 1-3,10-15, 17 |
| X | US, A, 2,034,484 (Pagendarm) 17 March 1936, see the entire document. | 4,5,16 |
| Y | US, A, 1,704,133 (LeClaire) 5 March 1929, see the entire document. | 6-8,18-20 |
| Y | US, A, 2,230,460 (Kleinwachter) 4 February 1941, see the entire document. | 9,21 |
| Y | US, A, 2,939,379 (Schmitt) 7 June 1960, see the entire document. | 1-21 |
| <p>* Special categories of cited documents: ¹⁵</p> <p>"A" document defining the general state of the art which is not considered to be of particular relevance</p> <p>"E" earlier document but published on or after the international filing date</p> <p>"L" document which may throw doubts on priority claim(s) or which is cited to establish the publication date of another citation or other special reason (as specified)</p> <p>"O" document referring to an oral disclosure, use, exhibition or other means</p> <p>"P" document published prior to the international filing date but later than the priority date claimed</p> <p>"T" later document published after the international filing date or priority date and not in conflict with the application but cited to understand the principle or theory underlying the invention</p> <p>"X" document of particular relevance; the claimed invention cannot be considered novel or cannot be considered to involve an inventive step</p> <p>"Y" document of particular relevance; the claimed invention cannot be considered to involve an inventive step when the document is combined with one or more other such documents, such combination being obvious to a person skilled in the art.</p> <p>"&" document member of the same patent family</p> | | |
| IV. CERTIFICATION | | |
| Date of the Actual Completion of the International Search ² | Date of Mailing of this International Search Report ² | |
| 20 May 1987 | 09 JUN 1987 | |
| International Searching Authority ¹ | Signature of Authorized Officer ²⁰ | |
| ISA/US | <i>Frederick R. Handren</i> Frederick R. Handren | |

| III. DOCUMENTS CONSIDERED TO BE RELEVANT (CONTINUED FROM THE SECOND SHEET) | | |
|--|--|------------------------------------|
| Category * | Citation of Document, ¹⁶ with indication, where appropriate, of the relevant passages ¹⁷ | Relevant to Claim No ¹⁸ |
| Y | US, A, 3,253,532 (Jones) 31 May 1966, see the entire document. | 1-3, 10-15 |
| Y | US, A, 3,783,820 (Hautly) 8 January 1974, see the entire document. | 1-21 |
| Y | US, A, 3,197,076 (Chamblee) 27 July 1965, see the entire document. | 1,4, 10-14 |