

E. F. BEUGLER.  
MACHINE FOR MAKING BARRELS.  
APPLICATION FILED JAN. 23, 1913.

1,154,684.

Patented Sept. 28, 1915.

3 SHEETS—SHEET 1.

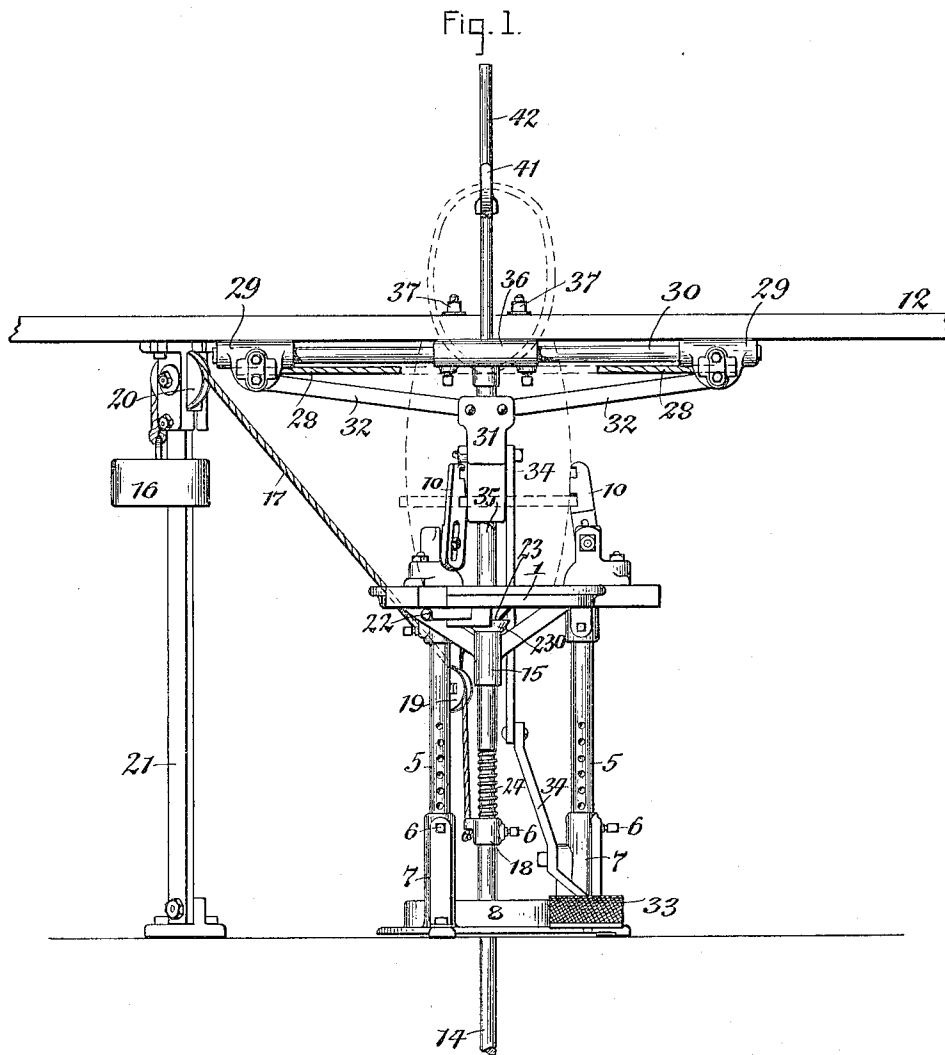

WITNESSES  
Walter P. Geyer.  
Anna Heigis

INVENTOR  
Edwin F. Beugler  
BY Geyer & Tobb  
ATTORNEYS

E. F. BEUGLER.  
MACHINE FOR MAKING BARRELS.  
APPLICATION FILED JAN. 23, 1913.

1,154,684.

Patented Sept. 28, 1915.

3 SHEETS—SHEET 2.

Fig. 2.

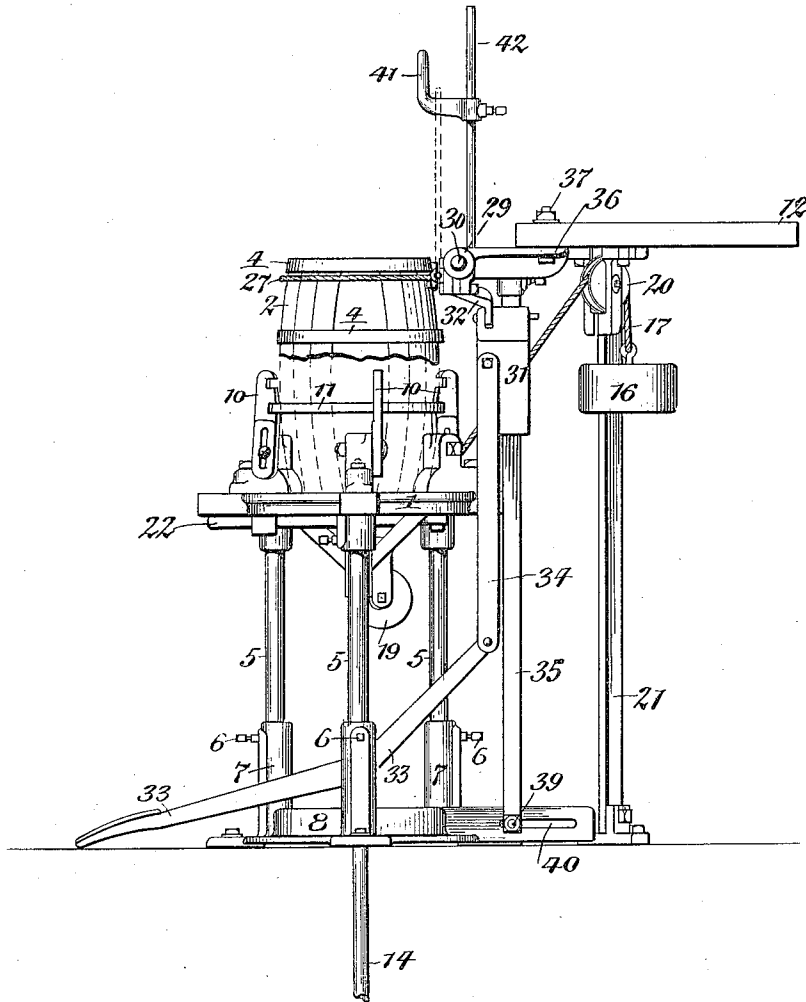

WITNESSES  
Walter P. Kaysers.  
Anna Heigis

INVENTOR  
Edwin F. Beugler  
BY *Super & Sopp*  
ATTORNEYS.

E. F. BEUGLER.  
 MACHINE FOR MAKING BARRELS.  
 APPLICATION FILED JAN. 23, 1913.

1,154,684.

Patented Sept. 28, 1915.

3 SHEETS—SHEET 3.

Fig. 3.

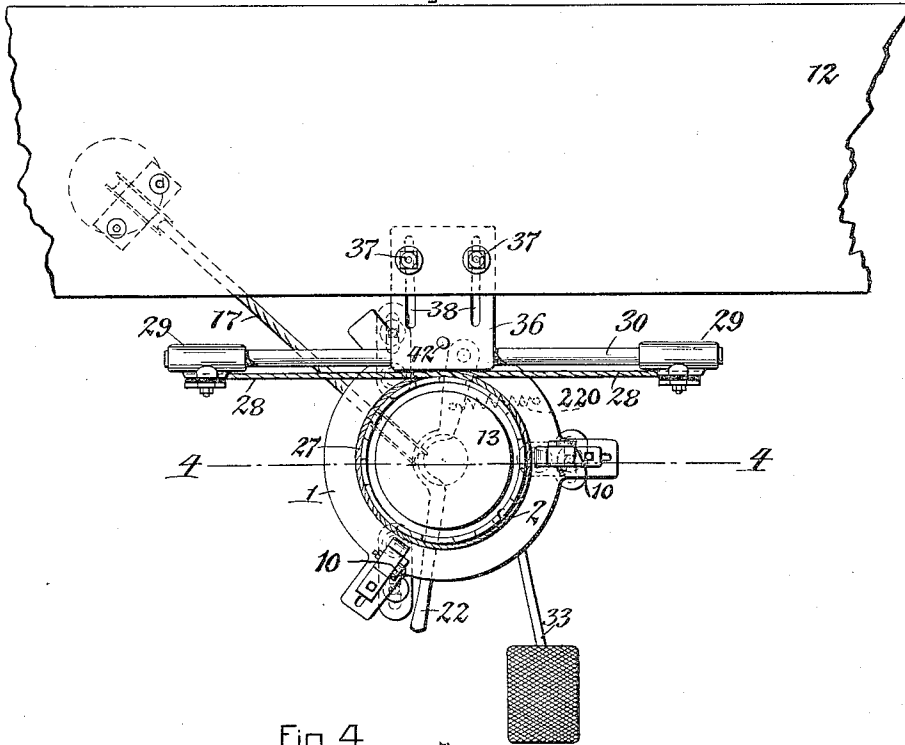
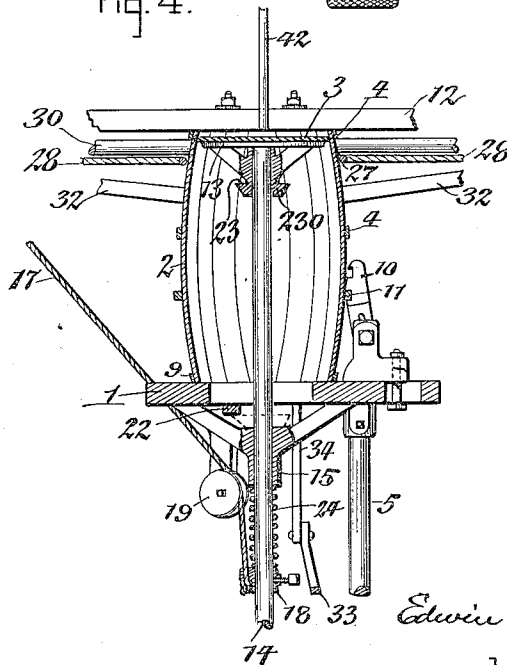

Fig. 4.



WITNESSES  
 Walter P. Seiper.  
 Anna Heigie

INVENTOR  
 Edwin F. Beugler  
 BY Seiper & Seiper  
 ATTORNEYS.

# UNITED STATES PATENT OFFICE.

EDWIN F. BEUGLER, OF BUFFALO, NEW YORK, ASSIGNOR TO E. & B. HOLMES  
MACHINERY COMPANY, OF BUFFALO, NEW YORK, A CORPORATION OF NEW  
YORK.

MACHINE FOR MAKING BARRELS.

1,154,684.

Specification of Letters Patent. Patented Sept. 28, 1915.

Application filed January 23, 1913. Serial No. 743,695.

*To all whom it may concern:*

Be it known that I, EDWIN F. BEUGLER, a citizen of the United States, residing at Buffalo, in the county of Erie and State of New York, have invented new and useful Improvements in Machines for Making Barrels, of which the following is a specification.

This invention relates to a machine for making barrels and more particularly to a machine for this purpose in which the staves are first assembled loosely upon a suitable support and then drawn together for securing the head and permitting the hoops to be applied thereto.

It is the object of this invention to provide an improved machine of this character in which the head may be reliably and conveniently raised and supported preparatory to contracting a set of staves about the same and to provide simple and efficient means whereby the barrel supporting and stave contracting means may be quickly adjusted to suit barrels of different sizes.

In the accompanying drawings consisting of 3 sheets: Figure 1 is a front elevation of a barrel making machine embodying my improvements. Fig. 2 is a side elevation thereof. Fig. 3 is a top plan view thereof. Fig. 4 is a fragmentary vertical transverse section taken in line 4-4, Fig. 3.

Similar characters of reference indicate corresponding parts throughout the several views.

1 represents a horizontal table which is adapted to support the lower end of a set of staves 2 of a barrel in a loosely assembled condition preparatory to securing the head 3 between the upper ends of the staves and applying the upper hoops 4 to the outer sides thereof. This table is mounted for vertical adjustment so as to adapt the same for making barrels which vary in length or height, the preferred means for this purpose comprising a plurality of upright supporting rods or legs 5 secured at a suitable distance apart at their upper ends to the underside of the table while their lower ends are adjustably secured by means of set screws 6 in vertical sockets 7 formed on a base 8 which rests on the floor. The barrel staves are assembled vertically in an annular row upon this table with their lower ends arranged within a lower end hoop 9 resting on the table and the same are held in the

central position on the table by means of a plurality of supporting dogs 10 arranged around the staves and each adjustably connected at its lower end with the table while its upper end engages with a lower bilge hoop 11 surrounding the staves at a distance from the lower ends thereof.

The upper head of the barrel is adapted to be secured at its edge in the usual chines at the upper ends of the several staves. This head is supported in line with the chines of the staves preparatory to contracting the latter into engagement with the barrel head by means of a vertically movable support 13 which is preferably constructed in the form of a horizontal disk. The head supporting disk is mounted on the upper end of an upright lifting rod 14 which is arranged centrally with reference to the supporting table and slides vertically with its lower part in a tubular guideway 15 mounted on the underside of the table. This supporting disk and the head resting thereon together with its lifting rod are raised when free by means which preferably comprise a weight 16, and a rope 17 or similar flexible member connected at one end with said weight and at its opposite end with a lifting collar 18 secured to the lifting rod while its intermediate part passes around a guide roller or wheel 19 mounted on the underside of the supporting table and a guide roller or wheel 20 mounted on the underside of a horizontal top plate 12. This supporting plate forms part of a stationary bench or frame which is arranged in rear of the barrel support and is provided with legs or standards 21 whereby the same is mounted on the floor.

While assembling the staves in an annular row on the supporting table the head supporting disk with the head resting thereon is held in its depressed position by a catch, lock or detent 22 mounted on the stave supporting table and releasably engaging with a shoulder 23 on the head supporting disk. Upon withdrawing this catch the head supporting disk is raised by the action of the weight 16.

The catch 22 is preferably constructed in the form of a lever pivoted to swing horizontally on the underside of the supporting table and is yieldingly held in its operative position by a spring 220, see Fig. 3, the shoulder 22 is formed at the upper end of a downwardly tapering cone 230 so that upon

depressing this cone with the head supporting disk the cone will deflect the catch lever and the latter when arranged in line with the shoulder 23 will be moved automatically over the same by the spring 220.

For the purpose of cushioning the upward movement of the lifting rod and preventing this movement from being arrested suddenly at the upper end of the stroke a cushioning device is provided which preferably consists of a spring 24 surrounding the lifting rod and bearing at its lower end against the lifting collar 18 and at its upper end against the guideway 15, as shown in Fig. 4. The head is preferably carried slightly above the chines in the staves and then depressed slightly by hand in line with the chines preparatory to contracting the upper ends of the staves so that the chines thereof engage with the edge of the barrel head and secure the latter between the same.

The contraction of the upper ends of the set of staves for engaging the chines thereof with the edge of the upper barrel head preparatory to applying the upper hoops 4 thereto is effected by means which preferably comprise a flexible line or cable which has its central part doubled to form a loop or noose 27 which is placed around the outer side of the barrel staves while the ends 28 thereof are connected with means whereby the same are drawn in opposite directions for tightening the loop around the staves and causing the latter to be contracted into engagement with the barrel head. The preferred means for thus drawing out the ends of the cable comprise two horizontally movable slides or carriages 29, 29 which are connected with opposite ends respectively of the cable and which are adapted to slide on opposite ends of a horizontal guide rod 30 arranged transversely above the rear part of the stave supporting table. These cable slides are caused to move toward and from each other for either loosening or tightening the loop of the cable by means which comprise a vertically movable toggle slide 31, two toggle bars or links 32 connecting opposite sides of the toggle slide with the cable carriages 29 respectively, a treadle or foot lever 33 pivotally mounted on the base of the supporting table, and an upright lifting link 34 connecting the rear arm of this foot lever with the toggle slide. The latter is sufficiently heavy so that its weight together with the parts associated therewith tend normally to hold the same in a depressed position so that the cable slides are arranged close together and the loop of the cable is expanded or enlarged.

During its vertical movement the toggle slide is guided on an upright guide bar 35 arranged in rear of the supporting table.

After the staves of the barrel have been assembled on the supporting table and the

head has been raised within the same to the proper position the loop of the cable is placed about the upper ends of the staves after which the front arm of the treadle is depressed, thereby causing the toggle slide to rise and the cable slides to move in opposite directions away from each other, whereby the loop of the cable is contracted and the upper ends of the several staves are bent inwardly into engagement with the edge of the barrel head. While the staves are in this position the upper hoops are applied thereto for completing this end of the barrel.

It has been found in practice that the pull on the end of the cable should be tangential to the periphery of the circular row of barrel staves in order to avoid any lateral strain or displacement upon the staves at this time. In order therefore to adapt the operating mechanism of the cable to suit barrels of different diameters this operating mechanism is adjustably supported so that it can be moved bodily toward and from the stave supporting table and head supporting disk to suit the different sizes of barrels which may be made. The preferred means for this purpose which are shown in the drawings comprise—a bracket 36 the front end of which carries the central part of the horizontal guide rod 30 while the rear end thereof is capable of horizontal adjustment forwardly and backwardly relatively to the center of the stave and head supports by means of bolts 37 passing through the top plate of the stationary frame or bench and through horizontal longitudinal slots 38 in the supporting bracket. The upper end of the guide rod or bar 35 of the toggle slide is secured to the underside of this adjusting bracket 36 so that the guides for the cable slides and the toggle slide can be adjusted simultaneously forwardly and backwardly to suit the size of barrel which is being made. The lower end of the guide rod 35 for the toggle slide is adjustably secured to the base of the supporting table by means of a bolt 39 secured in the lower end of this vertical guide bar and passing through a horizontal longitudinal slot 40 in the base, as shown in Fig. 2. During this adjustment fore and aft of the guide for the cable slides and the toggle slide no adjustment of the treadle is necessary inasmuch as the link 34 permits of such adjustment without affecting the operation of the treadle. By thus adjusting these guides the machine may be quickly adapted for making barrels of different sizes or diameters and after the adjustment has been effected all of the parts are again held rigidly in position relatively to each other.

While the staves of the barrel are being assembled on the supporting table the loop of the cable is preferably hung upon a hook 41 which is carried by a rod 42 on the ad-

justable bracket 36 so that this loop at this time is out of the way, as shown by dotted lines in Figs. 1 and 2 and does not interfere with the assembling of the staves.

5 If desired the stave contracting mechanism may be employed without using the head lifting device in which case the latter is held in its lowered inoperative position by the catch 22.

10 This machine is exceedingly simple and durable in construction and permits of making barrels of good workmanship expeditiously and economically and with a minimum expenditure of manual labor.

15 I claim as my invention:

20 A barrel making machine comprising a support for the assembled staves, a draw cable having a central loop shaped part adapted to surround the staves, and means for drawing apart the ends of the cable com-

prising two cable slides, a guide rod on which said slides are guided, a bracket carrying said guide rod and adjustable toward and from said stave support, a vertically movable toggle slide, toggle links connecting said toggle slide with said cable slides, an upright guide rod on which said toggle slide is guided and which is connected with said adjustable bracket, a base on which said stave support is mounted and with which the upright guide rod is adjustably connected, a treadle pivotally mounted on said base, and a link connecting said treadle with said toggle slide.

Witness my hand this 16th day of January, 1913.

EDWIN F. BEUGLER.

Witnesses:

LEON M. WOOSTER,  
IDA J. VISHION.

Copies of this patent may be obtained for five cents each, by addressing the "Commissioner of Patents, Washington, D. C."