



(22) Date de dépôt/Filing Date: 2005/10/13

(41) Mise à la disp. pub./Open to Public Insp.: 2006/04/15

(30) Priorités/Priorities: 2004/10/15 (UD 2004 A 000192) IT;
2004/11/26 (PCT/IT2004/000655) IT;
2005/04/06 (UD 2005 A 000053) IT;
2005/10/03 (US 2005 A 000164) IT

(51) Cl.Int./Int.Cl. *E04F 19/04* (2006.01)

(71) Demandeur/Applicant:
L.I.C.A.R. SPA, IT

(72) Inventeur/Inventor:
ROSSETTI, GUERRINO, IT

(74) Agent: GOUDREAU GAGE DUBUC

(54) Titre : PLINTHE

(54) Title: SKIRTING BOARD

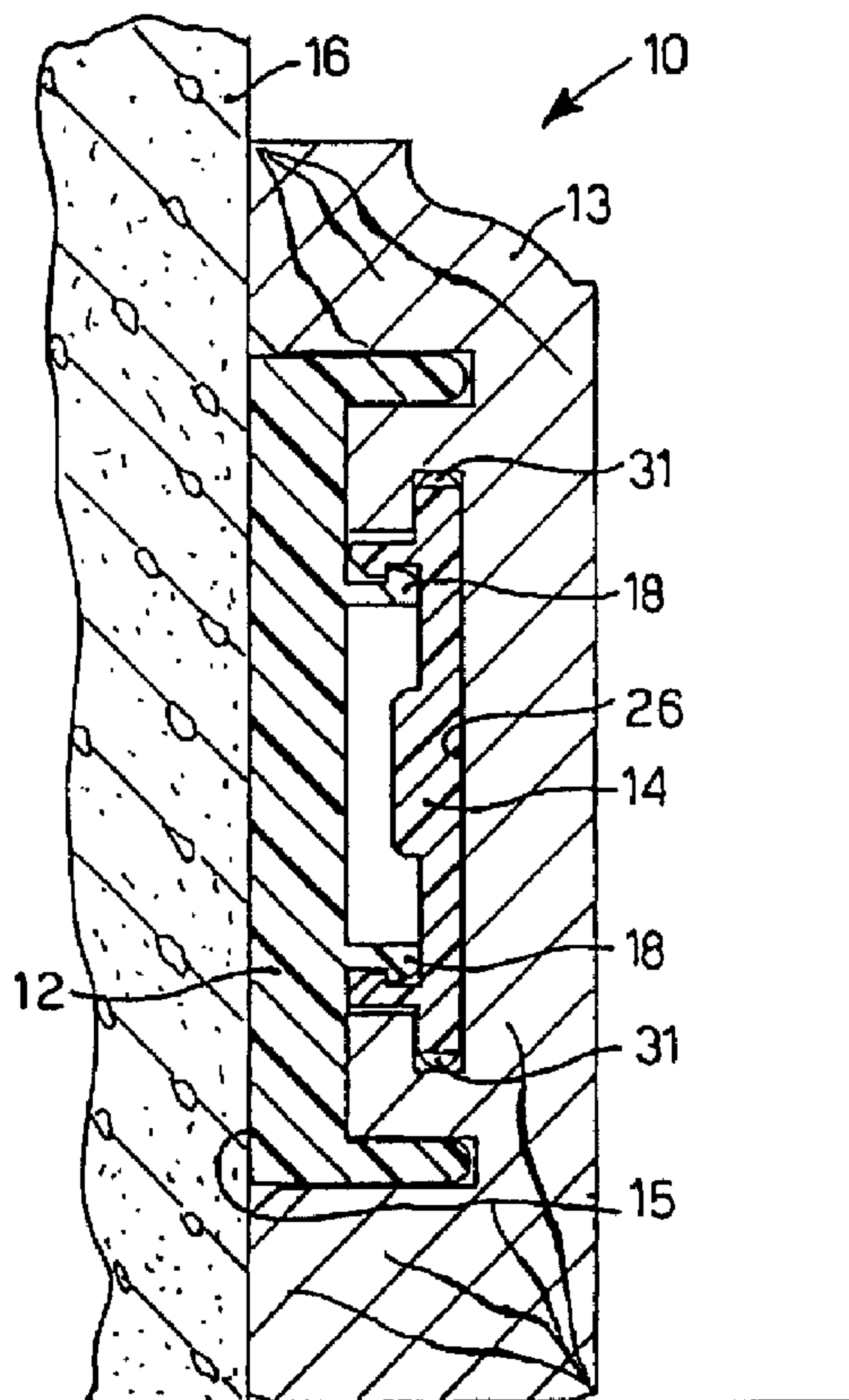

(57) Abrégé/Abstract:

Skirting board comprising at least a support able to be attached to a wall, and a covering able to be coupled with the support by the interposition of an intermediate element. The support comprises a base plate and at least a first guide, rectilinear and perpendicular to the base plate, and is provided with first attachment elements able to couple in snap-in manner with second attachment

(57) **Abrégé(suite)/Abstract(continued):**

elements made on the intermediate element, so that the intermediate element is free to slide along the first guide, maintaining itself parallel to the base plate. The covering comprises a substantially rectilinear groove parallel to the base plate and able to couple with pads of the intermediate element, so that the covering and the intermediate element are able to slide freely one with respect to the other, maintaining the covering parallel to the base plate.

- 17 -

ABSTRACT

Skirting board comprising at least a support able to be attached to a wall, and a covering able to be coupled with the support by the interposition of an intermediate
5 element. The support comprises a base plate and at least a first guide, rectilinear and perpendicular to the base plate, and is provided with first attachment elements able to couple in snap-in manner with second attachment elements made on the intermediate element, so that the intermediate
10 element is free to slide along the first guide, maintaining itself parallel to the base plate. The covering comprises a substantially rectilinear groove parallel to the base plate and able to couple with pads of the intermediate element, so that the covering and the intermediate element are able
15 to slide freely one with respect to the other, maintaining the covering parallel to the base plate.

- 1 -

"SKIRTING BOARD"

* * * * *

FIELD OF THE INVENTION

The present invention concerns a skirting board
5 comprising a base support attachable to a wall and a
covering able to be coupled with the base support by means
of an intermediate element. In general, the invention can
be applied to any furnishing element whatsoever provided
with a base support and a covering, and able to be used,
10 for example, for framing, or molding for walls or ceilings.

BACKGROUND OF THE INVENTION

Skirting boards are known, which comprise a base support,
attachable to a wall, for example with screws, and at least
a covering made for example of wood, which is coupled with
15 the base support with screws or by gluing.

Known skirting boards have the disadvantage that, during
the installation steps, centering the covering with respect
to the support is a long and often imprecise operation.
Moreover, removing the covering from the support, for
20 example for subsequent maintenance, is a difficult
operation which also entails the danger of detaching the
support from the wall and of causing damage to the latter.

A connection element for floors is also known, provided
with an intermediate element connectable on one side to a
25 first U-shaped element made in the base support, and on the
opposite side to a second U-shaped element made in the
covering. The U-shaped elements and the intermediate
element have a relatively high development in height in
order to adapt to the thickness of the floor equal to some
30 centimeters: consequently, the covering is in a very
distant position from the support and does not rest on the
wall. This solution does not therefore guarantee a
sufficiently stable coupling between the support and the

- 2 -

covering, which can therefore easily become detached.

One purpose of the present invention is to achieve a skirting board, of the type having a covering able to be coupled by means of an intermediate element to a support
5 fixed to the wall, which ensures a secure and long-lasting coupling between the covering and the support.

Another purpose of the present invention is to achieve a skirting board that can be installed quickly and precisely, that can be positioned and adjusted easily, and that can be
10 adapted simply in order to cover the corners formed by two walls.

Another purpose of the present invention is to achieve a skirting board in which the covering can be removed from the support simply, quickly and without causing damage to
15 the wall or unwanted detachments of the support from the latter.

The Applicant has devised, tested and embodied the present invention to overcome the shortcomings of the state of the art and to obtain these and other purposes and
20 advantages.

SUMMARY OF THE INVENTION

The present invention is set forth and characterized in the main claim, while the dependent claims describe other characteristics of the invention or variants to the main
25 inventive idea.

In accordance with the above purposes, a skirting board according to the present invention is of the type comprising at least a supporting element, able to be attached to a wall, and a covering element able to be
30 coupled with the supporting element by the interposition of at least an intermediate element.

The supporting element is made for example of a plastic material comprising at least nylon, or a polyamide resin,

- 3 -

or of metal, while the covering element can be made of plastic material, metal, wood, MDF or a wood substitute materials.

It is also provided that the covering element is of the
5 type comprising an inner body made for example of plastic material or metal, and an outer covering layer made of wood, MDF or wood substitute materials.

The supporting element comprises a base plate, able to be positioned near said wall, and at least a first guide,
10 substantially rectilinear and perpendicular to the base plate and provided with first coupling means able to selectively couple with the intermediate element.

The covering element comprises second coupling means able to selectively couple with the intermediate element.

15 According to a characteristic of the present invention, the second coupling means comprise a groove, substantially rectilinear and parallel to the base plate. Moreover, the intermediate element comprises both third coupling means able to couple in snap-in manner with the first coupling
20 means, so that the intermediate element is free to slide along the first guide, keeping itself substantially parallel to the base plate, and also fourth coupling means able to couple with the groove, so that the covering element and the intermediate element can slide freely one
25 with respect to the other, keeping the covering element substantially parallel to the base plate.

In this way, once the supporting element has been attached to the wall, the covering element of the skirting board according to the present invention can be coupled
30 with the supporting element quickly and precisely thanks to the snap-in coupling of the first coupling means and the third coupling means.

Thanks to the invention, given that the intermediate

- 4 -

element is free to slide substantially parallel to the base plate along the first guide, the covering can be positioned and regulated with respect to the supporting element, and to other possible adjacent covering elements, with great
5 precision.

According to one embodiment of the invention, the intermediate element also comprises a frame able to be inserted into the groove in sliding manner. In this way, the overall height of the intermediate element and the
10 first guide, in their coupled condition, is extremely reduced, guaranteeing great stability to the coupling between the covering element and the supporting element.

The fourth coupling means comprise two pad elements made on two opposite sides of the frame and able to contact
15 respectively two opposite walls of the groove in order to maintain the intermediate element constrained to the groove in a direction substantially orthogonal to the rectilinear development of the groove.

In this way, the invention allows to position the
20 intermediate element in any one desired position with respect to the groove of the covering.

The covering element comprises a shaped notch able to contain the groove and to accommodate the supporting element and the intermediate element inside it, so that the
25 covering element contacts the wall on which the supporting element is attached, further improving its stability.

According to one embodiment, the supporting element also comprises at least a second guide having a greater height with respect to that of the first guide. Advantageously,
30 the second guide has a greater height than the overall height of the first guide and the intermediate element in their coupled condition.

The notch on the covering element is shaped so as to also

- 5 -

contain at least a slit able to accommodate the second guide; the slit functions as a lead-in to center the covering element with respect to the supporting element during the operations to assemble the skirting board.

5 Advantageously, the slit extends inside the covering element more than the groove extends.

According to another advantageous embodiment, the supporting element laterally comprises first connection means able to be coupled with corresponding second
10 connection means of a second supporting element, in order to connect the two supporting elements defining a hinge-type connection.

The skirting board according to the invention can therefore be installed and adapted simply, quickly and
15 economically, also to cover the corners formed by two walls.

According to another advantageous embodiment, the skirting board according to the present invention also comprises hook means able to be constrained to the
20 supporting element and to support at least electric feed cables, signal cables or pipes. The hook means are able to be contained in at least a longitudinal groove made in the covering element, and are thus hidden from sight.

According to another advantageous embodiment, the
25 covering element is provided with at least a cavity, for example through, thanks to which the covering element can be selectively removed from the supporting element, for example using a screwdriver, simply, quickly and without causing damage to the wall or detaching the support from
30 the latter.

BRIEF DESCRIPTION OF THE DRAWINGS

These and other characteristics of the present invention will become apparent from the following description of a

- 6 -

preferential form of embodiment, given as a non-restrictive example with reference to the attached drawings wherein:

- fig. 1 is a lateral section of a skirting board according to the present invention attached to a wall;
- 5 - fig. 2 is a lateral section of a support of the skirting board in fig. 1;
- fig. 3 is a plane view of the support in fig. 2;
- fig. 4 is a plane view of two supports of the skirting board connected with each other;
- 10 - fig. 5 is a lateral section of a covering of the skirting board in fig. 1;
- fig. 6 is a lateral section of a connection element of the skirting board in fig. 1;
- fig. 7 is a plane view of the connection element in fig. 15 6;
- fig. 8 is an enlarged detail of fig. 1;
- fig. 9 is a lateral view, partly in section, of a variant of the skirting board in fig. 1;
- fig. 10 is a plane view of a support of the variant of 20 the skirting board in fig. 9;
- fig. 11 is a section from XI to XI of fig. 10;
- fig. 12 is a front view of a covering of a variant of the skirting board in fig. 1;
- fig. 13 is a lateral view of another variant of the 25 skirting board in fig. 1;
- fig. 14 is an enlarged detail of another variant of the skirting board in fig. 1.

DETAILED DESCRIPTION OF A PREFERENTIAL FORM OF EMBODIMENT

With reference to fig. 1, a skirting board 10 according 30 to the present invention comprises a support 12, a covering 13 and an intermediate element 14, able to connect the support 12 and the covering 13.

The support 12 (figs. 1, 2 and 3) is made for example of

- 7 -

plastic material, such as nylon, polyamide resin, or other, and is attached to a wall 16 by means of screws.

The support 12 comprises a base plate 15 and two inner guides 18 which extend longitudinally with respect to the support 12 and perpendicular to the base plate 15 and are substantially parallel with respect to each other.

The inner guides 18 are also provided with respective protrusions 19 facing towards the outside of the support 12 and defining an attachment plane inclined by an angle of about 90° with respect to a respective axis X (fig. 8) passing through each inner guide 18 and substantially orthogonal to the base plate 15.

The support 12 (figs. 1, 2 and 3) also comprises a pair of outer guides 21 made along the two outer edges, upper and lower, of the support 12. The outer guides 21 extend longitudinally, substantially parallel to each other and substantially parallel to the inner guides 18, and are also provided with a rounded head.

The height of the outer guides 21 with respect to the surface of the base of the support 12, is greater than the height of the inner guides 18.

With reference to fig. 4, two supports, respectively 12a and 12b, can be positioned adjacent laterally to each other, and able to be reciprocally connected by means of hinging. To this purpose, each support 12a and 12b is provided at a respective lateral end with a male element 23 and a female element 24, staggered with respect to each other so that, when the two supports 12a and 12b are positioned laterally adjacent, the male element 23 of the first support 12a can be connected to the female element 24 of the second support 12b and the female element 24 of the first support 12a can be connected to the male element 23 of the second support 12b.

- 8 -

The male element 23 comprises a pin disposed substantially orthogonal to the inner guides 18 and parallel to the base plate 15 and slightly distanced from the lateral edge of the respective support 12a, 12b, while
5 the female element 24 comprises three little hooks reciprocally staggered so as to accommodate between them the corresponding pin in snap-in manner.

The two supports 12a and 12b can thus rotate reciprocally around the hinging axis for almost a whole turn, so that
10 the skirting board 10 can be installed simply even in correspondence with edges or corners between adjacent walls.

The covering 13 (figs. 1 and 5) made for example of wood or wood substitute materials, comprises a notch 25 shaped
15 so as to include an undercut groove 26 and a pair of slits 27.

The groove 26 and the slits 27 have a substantially longitudinal development and extend substantially parallel to the longitudinal axis of the covering 13. To be more
20 exact, the slits 27 are able to accommodate the outer guides 21 of the support 12 (fig. 1).

The intermediate element 14 (figs. 1, 6 and 7) is made of a material similar to that of the support 12 and comprises two central cross-pieces 29 lying on a plane P parallel to
25 the base plate 15 and substantially parallel to each other.

The intermediate element 14 also comprises two substantially parallel lateral cross-pieces 30, lying on the plane P joined orthogonally to the two central cross-pieces 29 and protruding with respect to the latter so as
30 to define an H-shaped frame.

Each lateral cross-piece 29 is provided on two of its opposite sides, in correspondence with its protruding parts, with two pads 31 lying on the plane P and facing

- 9 -

towards the outside of the H; the two lateral cross-pieces 29 are able to be inserted into the respective grooves 26 of the covering 13 and to contact respectively two opposite walls 26a, 26b (fig. 5) of the groove 26, constraining the intermediate element 14 to the covering 13 in a direction substantially orthogonal to the longitudinal axis of the groove 26.

Moreover, from each lateral cross-piece 30 a respective hook 32 protrudes with respect to an axis Y substantially orthogonal to the plane P. Each hook 32 is provided with a tooth 33 (figs. 6 and 8), the attachment plane of which defines an angle of about 90° with respect to the axis Y. The two hooks 32 are disposed so that the respective teeth 33 are facing towards the inside of the H.

The hooks 32 (fig. 8) of the two lateral cross-pieces 30 are able to be connected in snap-in and univocal manner to the protrusions 19 of each inner guide 18 of the support 12, so as to constrain the intermediate element 14 in sliding manner, and hence the covering 13, to the support 12.

We shall now describe the method to assemble the skirting board 10 according to the present invention.

In a first step, the support 12 is attached to the wall 16 by means of screws, gluing, or other known manner. In this step, it is also provided to hinge together two or more supports 12, 12a, 12b by coupling the respective male and female elements 23, 24, for example to allow to install the skirting board 10 in correspondence with the edge between two walls.

In a second step, the intermediate element 14 is constrained to the covering 13 by inserting the two lateral cross-pieces 30 into the groove 26.

In a third step, the covering 13, together with the

- 10 -

intermediate element 14, is brought near the support 12. Given that the outer guides 21 protrude more from the surface of the support 12 with respect to the inner guides 18, the inner surface of the covering 13 contacts first the
5 outer guides 21 which, thanks to their rounded head, facilitate their insertion into the respective slits 27.

When the outer guides 21 are inserted into the respective slits 27, the covering 13 is aligned with respect to the support 12 so as to allow the snap-in coupling of the hooks
10 32 of the intermediate element 14 and the inner guides 18 of the support 12.

According to the variant shown in figs. 9-11, the skirting board 10 comprises hooks 35 able to be clamped in snap-in manner to the outer edge of the support 12 so as to
15 protrude below and above with respect to the relative support 12 and able to support electric feed cables, signal cables, pipes or other. The covering 13 comprises two longitudinal seatings 38 made inside and able to accommodate the hooks 35 and the cables or pipes, which
20 thus remain completely hidden from view.

According to a variant, the hooks 35 are able to support raceways in which the cables or pipes are inserted.

According to the variant shown in fig. 12, the skirting board 10 comprises a covering 113 provided with a hole 40,
25 for example made at the front. To release the covering 113 from the support 12, a tool, for example a screwdriver, is inserted into the hole 40, and leverage applied on the support 12 below.

In this way, the operation of inserting the screwdriver
30 between the covering 13 and the wall 16 is avoided, and also the risk of causing damage both to the covering 13 and also to the wall 16.

Advantageously the covering 113 is associated with a

- 11 -

limited number of intermediate elements 14, for example one, in order to facilitate the removal thereof from the support 12.

Moreover, the covering 113 has a width smaller than that of the other coverings 13, for example equal to about 2-5 cm.

According to the variant shown in fig. 13, the skirting board 10 comprises a support 112 provided with two pairs of inner guides 18, distanced from each other and substantially parallel, on which respective intermediate elements 14 are attached. The skirting board 10 also comprises a covering 213 which is shaped inside so as to include two grooves 26, substantially parallel to each other, in which the lateral cross-pieces 30 of the respective intermediate elements 14 are inserted. In this way, the invention can also be applied to coverings 213 having a great height.

According to the variant shown in fig. 14, the attachment plane defined by each protrusion 19 is inclined by an angle of about 120° , in general by an angle comprised between about 110° and about 140° , with respect to the axis X, and the attachment plane defined by each tooth 33 is inclined by an equal angle with respect to the respective axis Y. In this way, the reciprocal attachment of each protrusion 19 and the respective teeth 33 is not univocal as in the case shown in fig. 8, but allows a relative movement, for example to compensate possible heat dilations, while still guaranteeing a secure attachment between the support 12 and the intermediate element 14.

It is clear that modifications and/or additions of parts may be made to the skirting board 10 as described heretofore, without departing from the field and scope of the present invention.

- 12 -

It is also clear that, although the present invention has been described with reference to some specific examples, a person of skill in the art shall certainly be able to achieve many other equivalent forms of skirting board, 5 having the characteristics as set forth in the claims and hence all coming within the field of protection defined thereby.

- 13 -

CLAIMS

1. Skirting board comprising at least a supporting element able to be attached to a wall, and a covering element able to be coupled with said supporting element by the interposition of at least an intermediate element, wherein said supporting element comprises a base plate and at least a first guide, substantially rectilinear and perpendicular to said base plate, wherein said supporting element is provided with first coupling means able to selectively couple with said intermediate element, wherein said covering element comprises second coupling means able to selectively couple with said intermediate element, wherein said second coupling means comprise a groove, substantially rectilinear and parallel to said base plate, and wherein said intermediate element comprises both third coupling means, able to couple in snap-in manner with said first coupling means, so that said intermediate element is free to slide along said first guide, maintaining itself substantially parallel to said base plate, and also fourth coupling means, able to couple with said groove, so that said covering element and said intermediate element are able to slide freely one with respect to the other, maintaining said covering element substantially parallel to said base plate.
2. Skirting board as in claim 1, wherein said intermediate element further comprises a frame, substantially flattened in shape, able to be inserted in sliding manner into said groove.
3. Skirting board as in claim 2, wherein said fourth coupling means comprise at least two pad elements made on two opposite sides of said frame.
4. Skirting board as in claim 3, wherein said pad elements are able to contact respectively two opposite walls of said

- 14 -

groove in order to maintain said intermediate element constrained to said groove in a direction substantially orthogonal to the rectilinear development of said groove.

5. Skirting board as in claim 2, wherein said first
5 coupling means comprise first attachment elements made on said first guide, and wherein said third coupling means comprise second attachment elements made on said frame and protruding towards said supporting element in a direction substantially orthogonal to said base plate, and able to be
10 coupled with said first attachment elements.

6. Skirting board as in claim 2, wherein said frame is formed by two lateral cross-pieces joined together by at least a central cross-piece disposed perpendicular to said lateral cross-pieces.

15 7. Skirting board as in claim 1, wherein said supporting element extends in a longitudinal direction and defines the path along which said covering element and said intermediate element are able to slide.

8. Skirting board as in claim 1, wherein said groove is
20 made as an undercut.

9. Skirting board as in claim 1, wherein said supporting element further comprises at least a second guide having a greater height than that of said first guide.

10. Skirting board as in claim 9, wherein the height of
25 said second guide is greater than the overall height of said first guide and of said intermediate element in their coupled condition.

11. Skirting board as in claim 9, wherein said covering element comprises a notch shaped so as to contain said
30 groove and to accommodate inside it said supporting element and said intermediate element.

12. Skirting board as in claim 11, wherein said notch is shaped so as to contain at least a slit able to accommodate

- 15 -

said second guide.

13. Skirting board as in claim 12, wherein said slit extends substantially parallel to said groove.

14. Skirting board as in claim 12, wherein said slit
5 extends inside the covering element more than said groove extends.

15. Skirting board as in claim 1, wherein said supporting element laterally comprises first connection means able to be connected to corresponding second connection means of a
10 second supporting element in order to connect said supporting elements with each other.

16. Skirting board as in claim 15, wherein said first and second connection means comprise male elements and respective female elements able to be coupled together so
15 as to define a hinge-type connection.

17. Skirting board as in claim 1, wherein it also comprises hook means, able to be constrained to said supporting element and to support at least electric feed cables, signal cables, or pipes.

20 18. Skirting board as in claim 17, wherein said covering element comprises at least a longitudinal seating able to accommodate said hook means and said electric feed cables, signal cables or pipes.

25 19. Skirting board as in claim 1, wherein said covering element is provided with at least a cavity for the selective removal of said covering element from said supporting element.

20. Skirting board as in claim 19, wherein said cavity is through.

30 21. Skirting board as in claim 1, wherein said supporting element is made of plastic material comprising at least nylon or a polyamide resin.

22. Skirting board as in claim 1, wherein said supporting

element is made of metal.

23. Skirting board as in claim 1, wherein said covering element is made of wood, MDF or wood substitute materials.

24. Skirting board as in claim 1, wherein said covering
5 element is made of plastic material.

25. Skirting board as in claim 1, wherein said covering element is made of metal.

26. Skirting board as in claim 24, wherein said covering
10 element comprises an outer covering layer made of wood, MDF
or wood substitute materials.

1/5

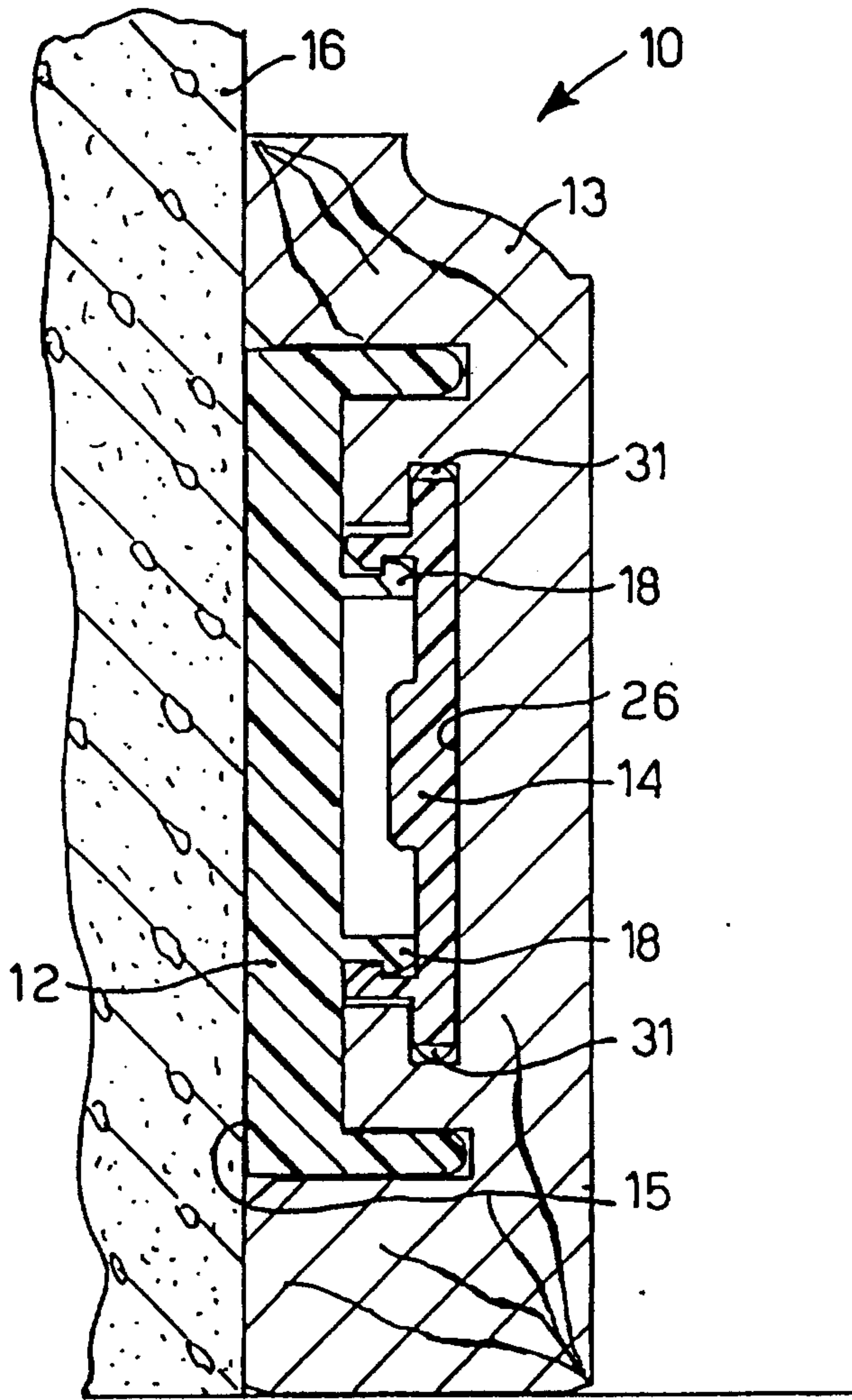

fig. 1

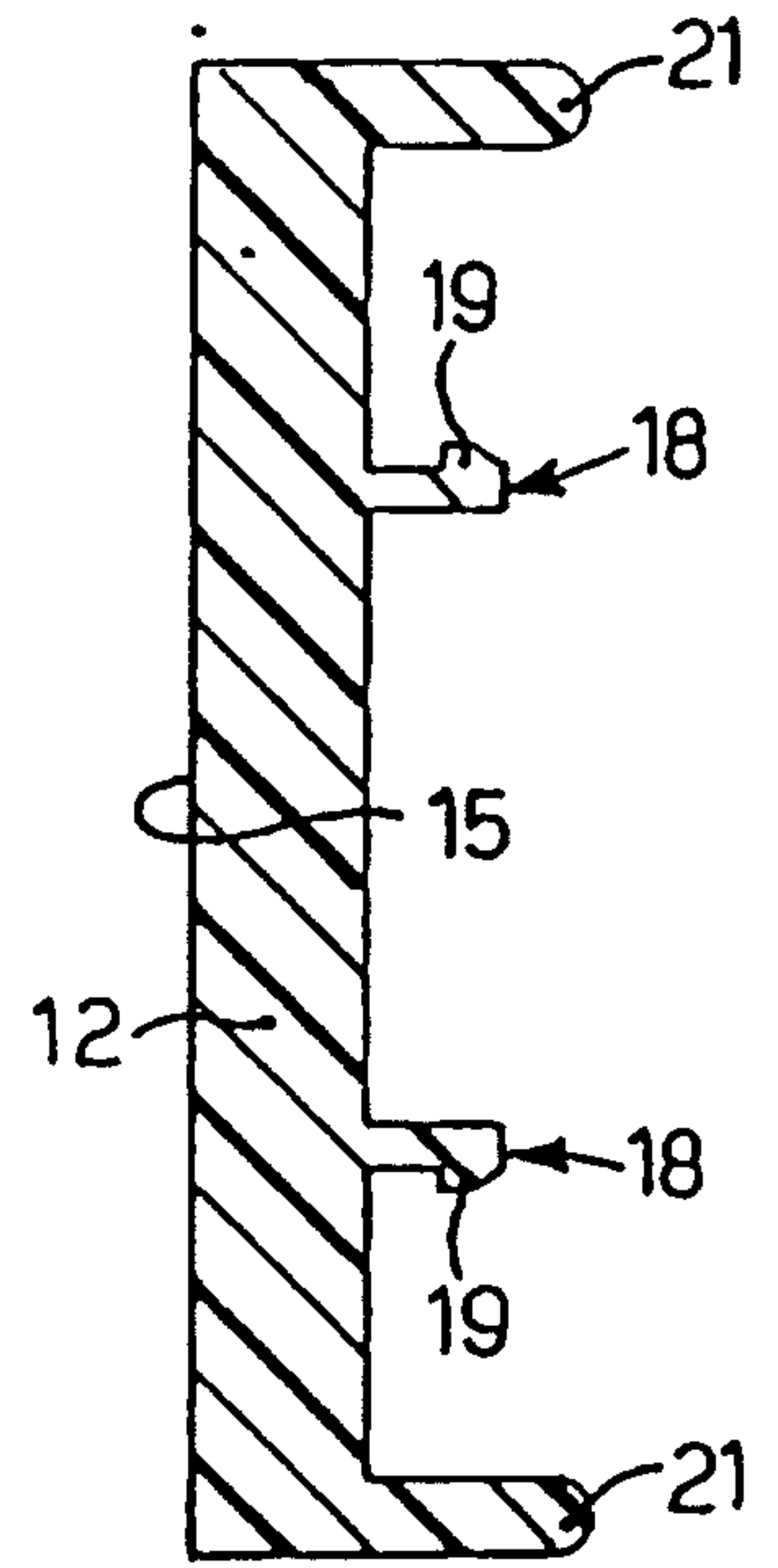

fig. 2

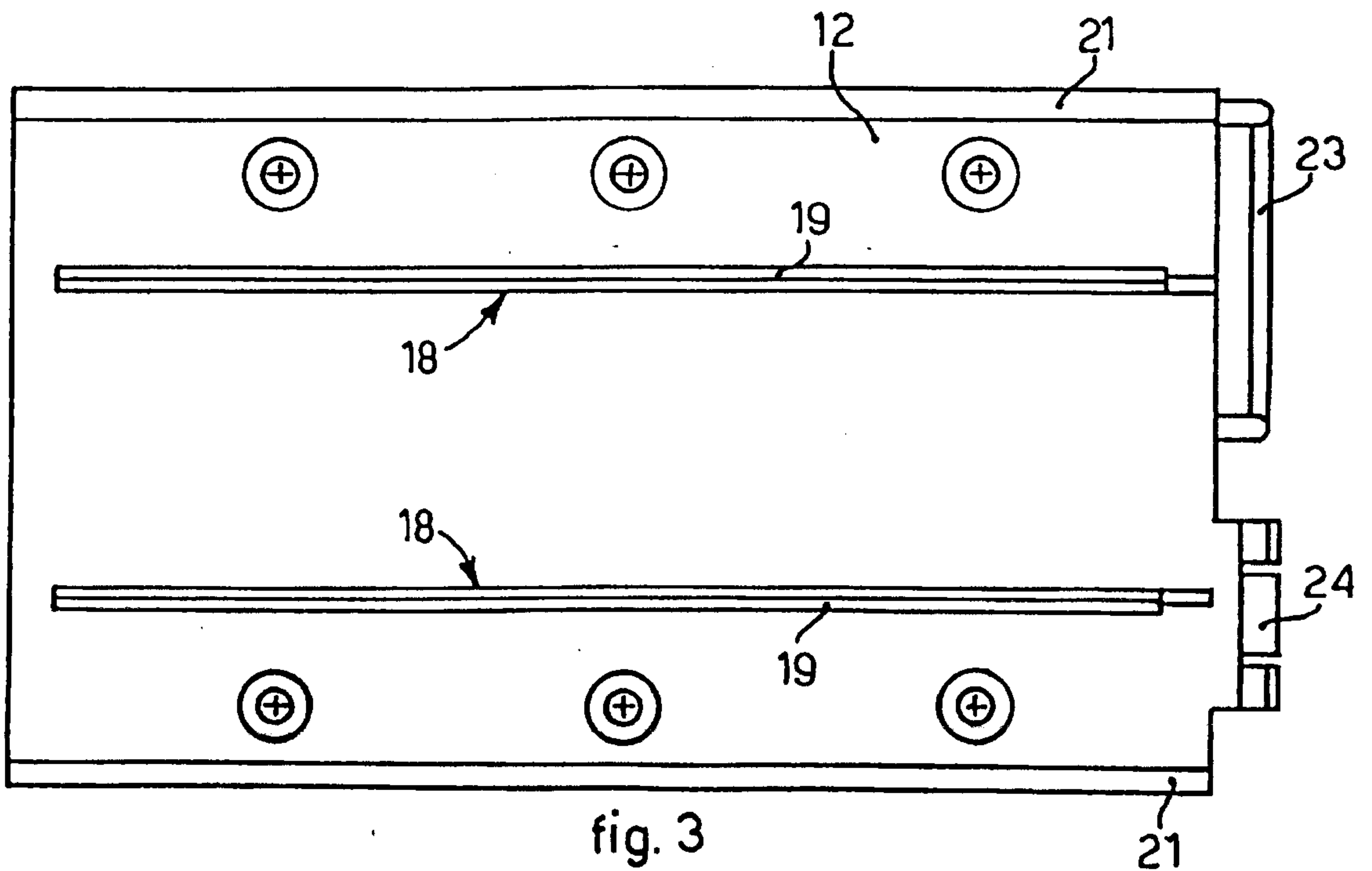

fig. 3

2/5

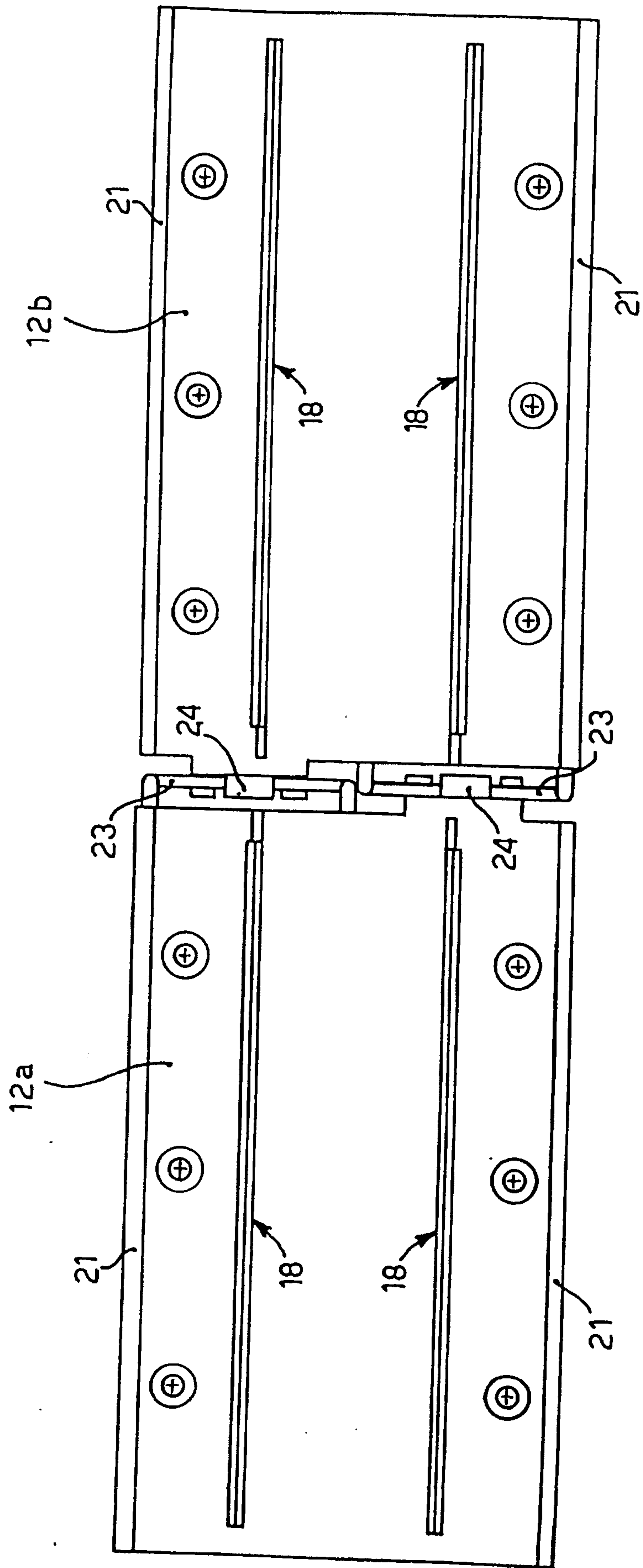

fig. 4

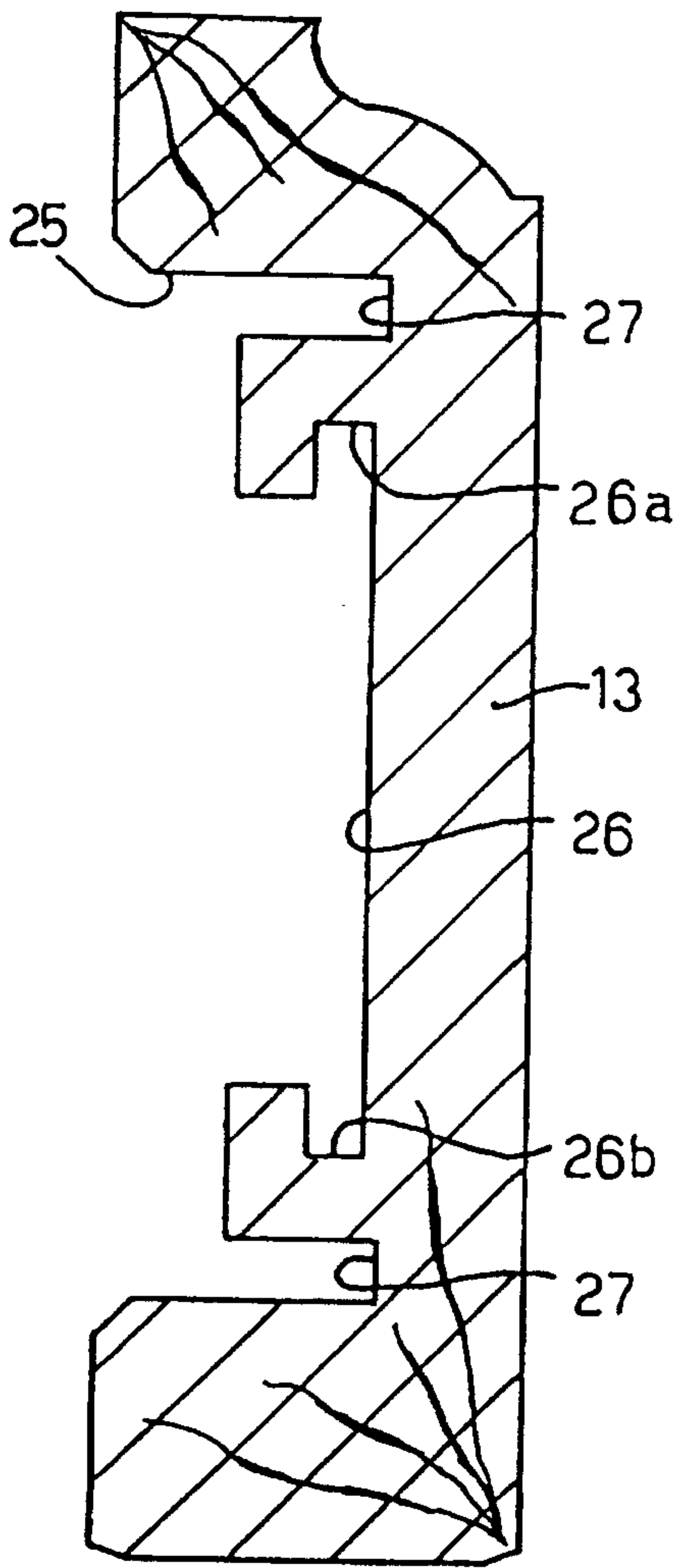

fig. 5

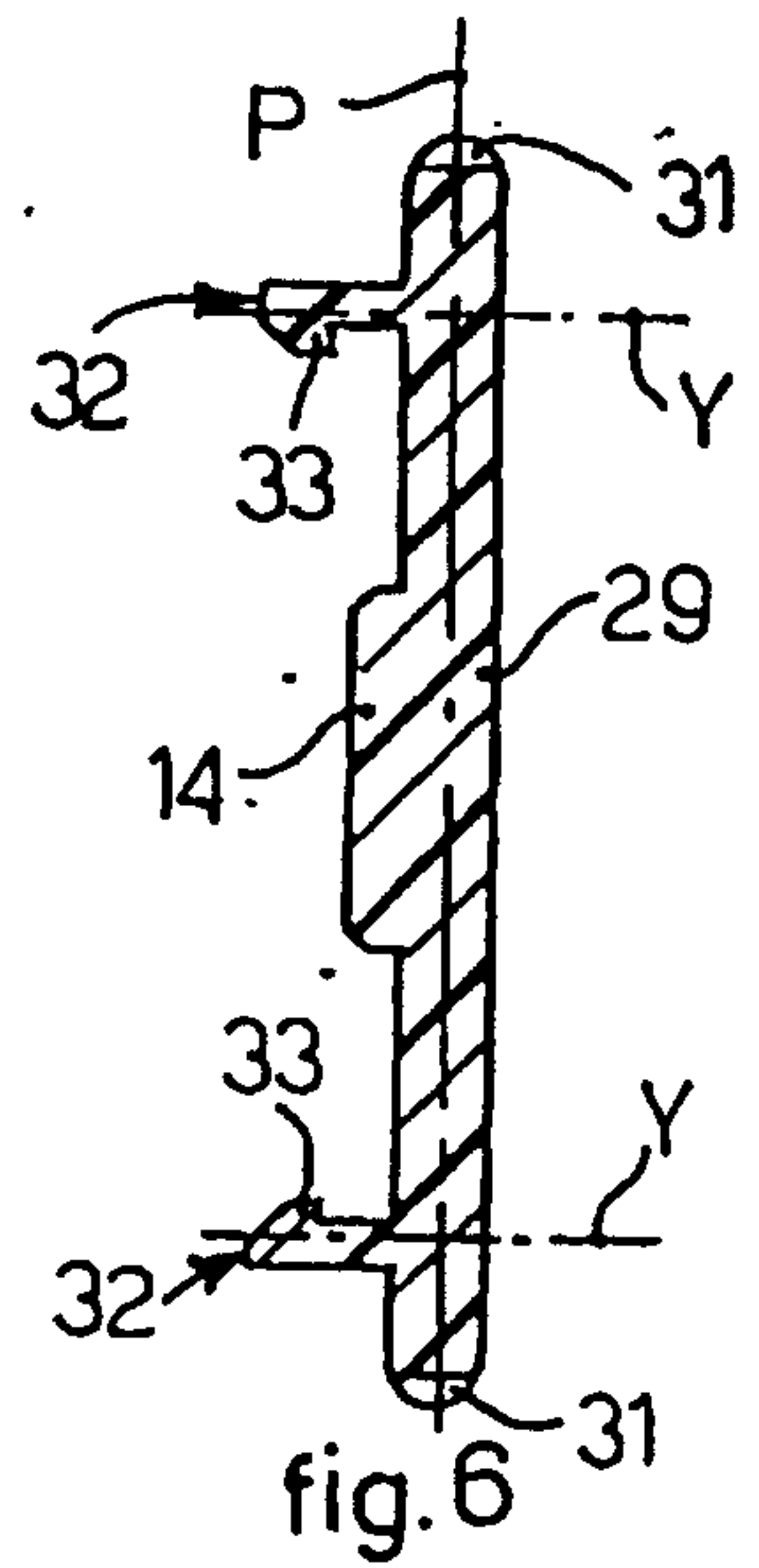

fig. 6

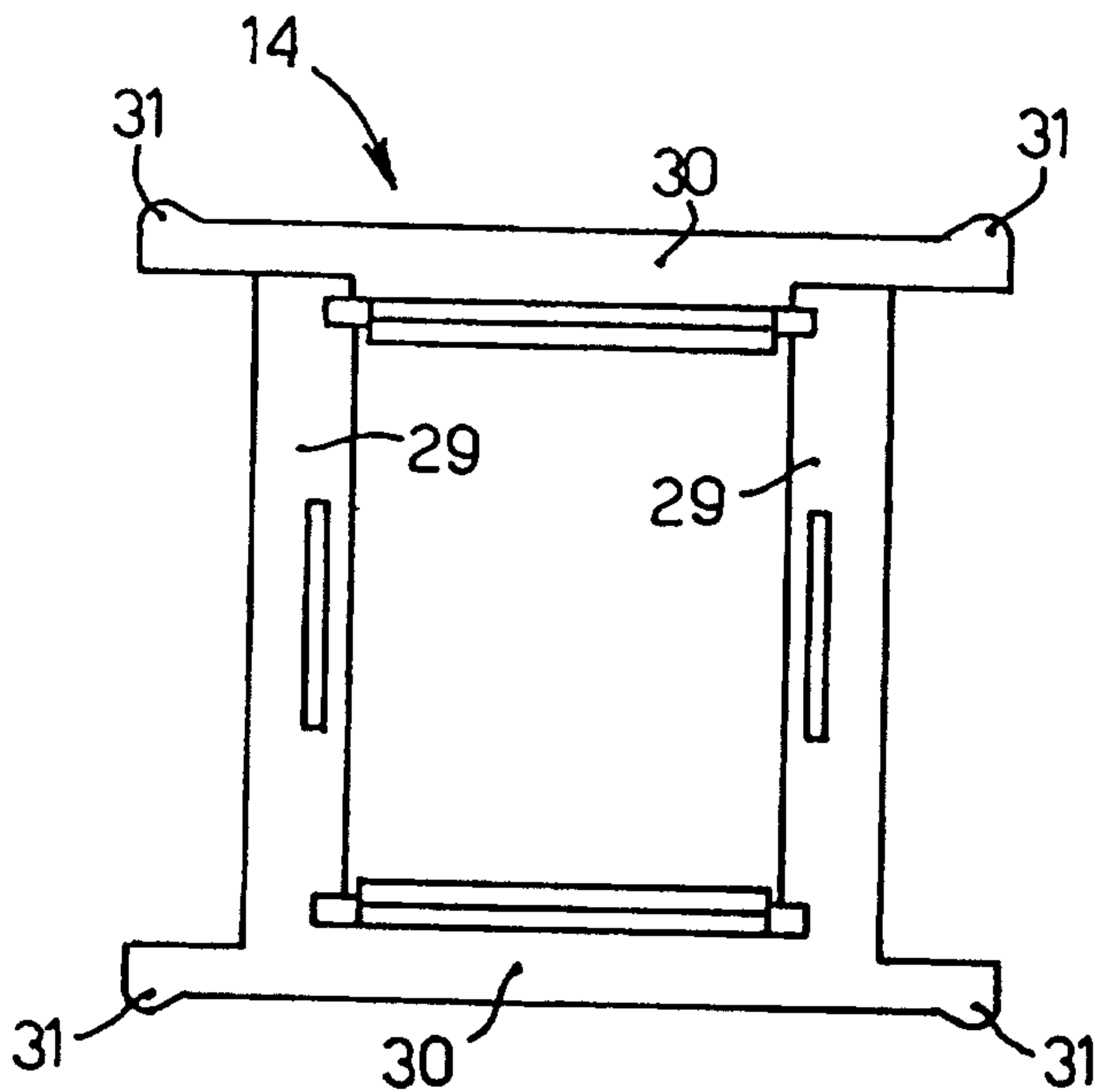

fig. 7

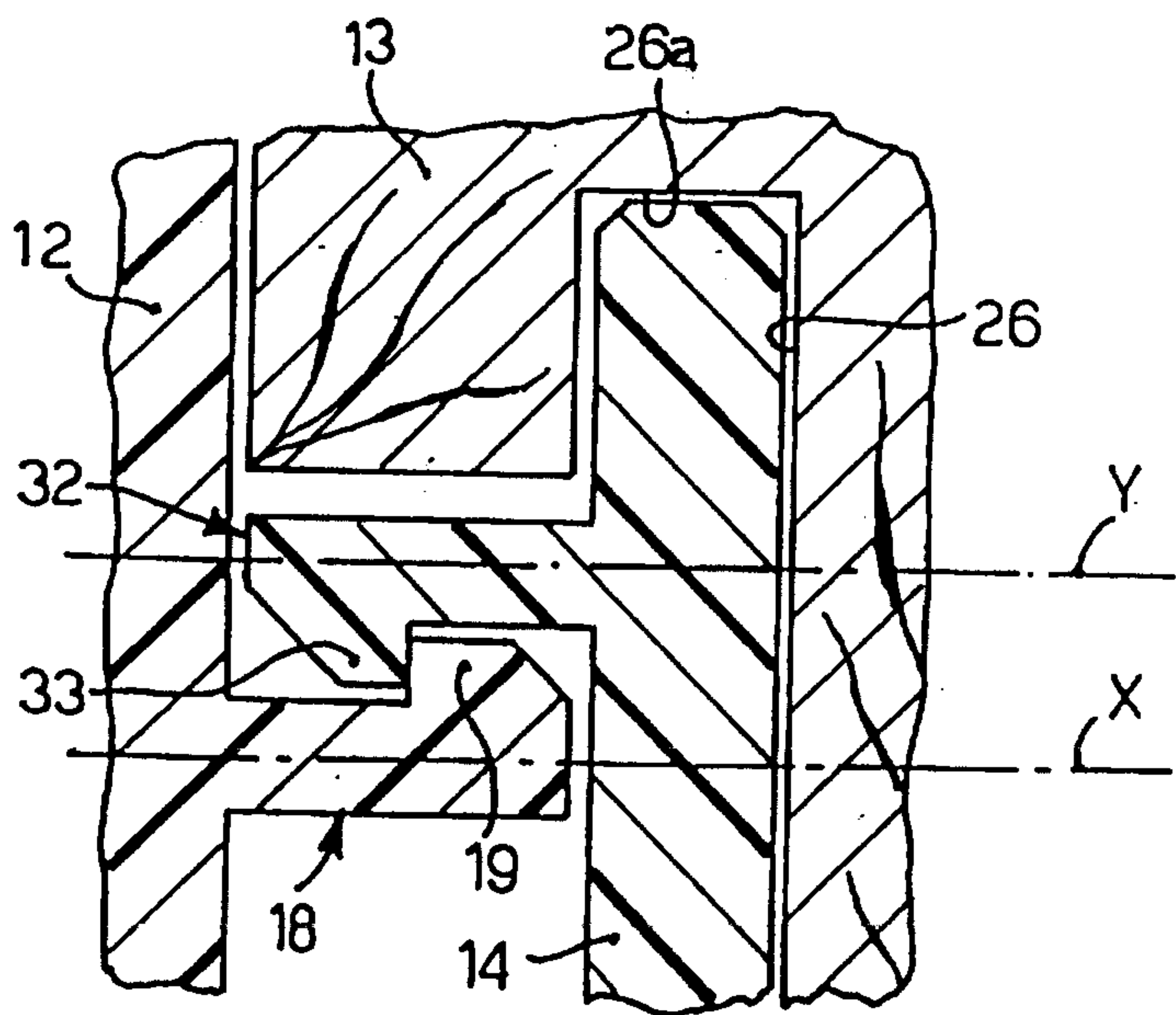

fig. 8

4/5

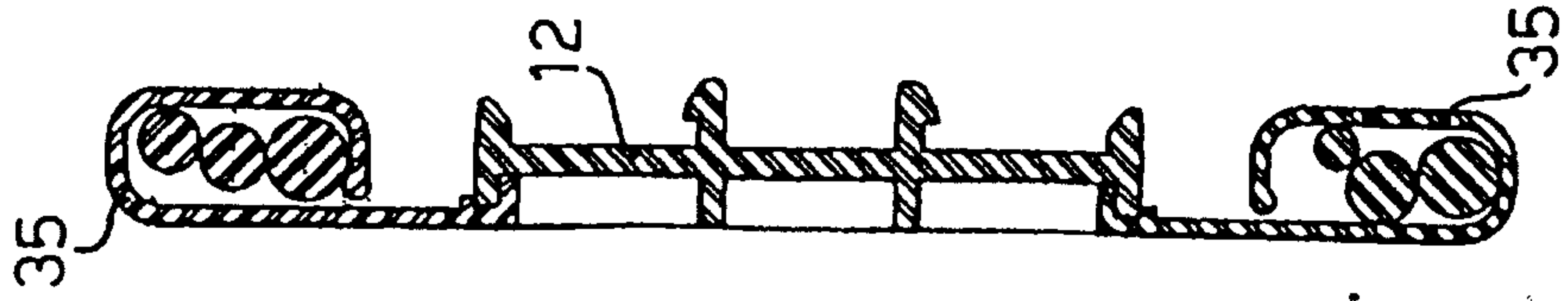

fig. 11

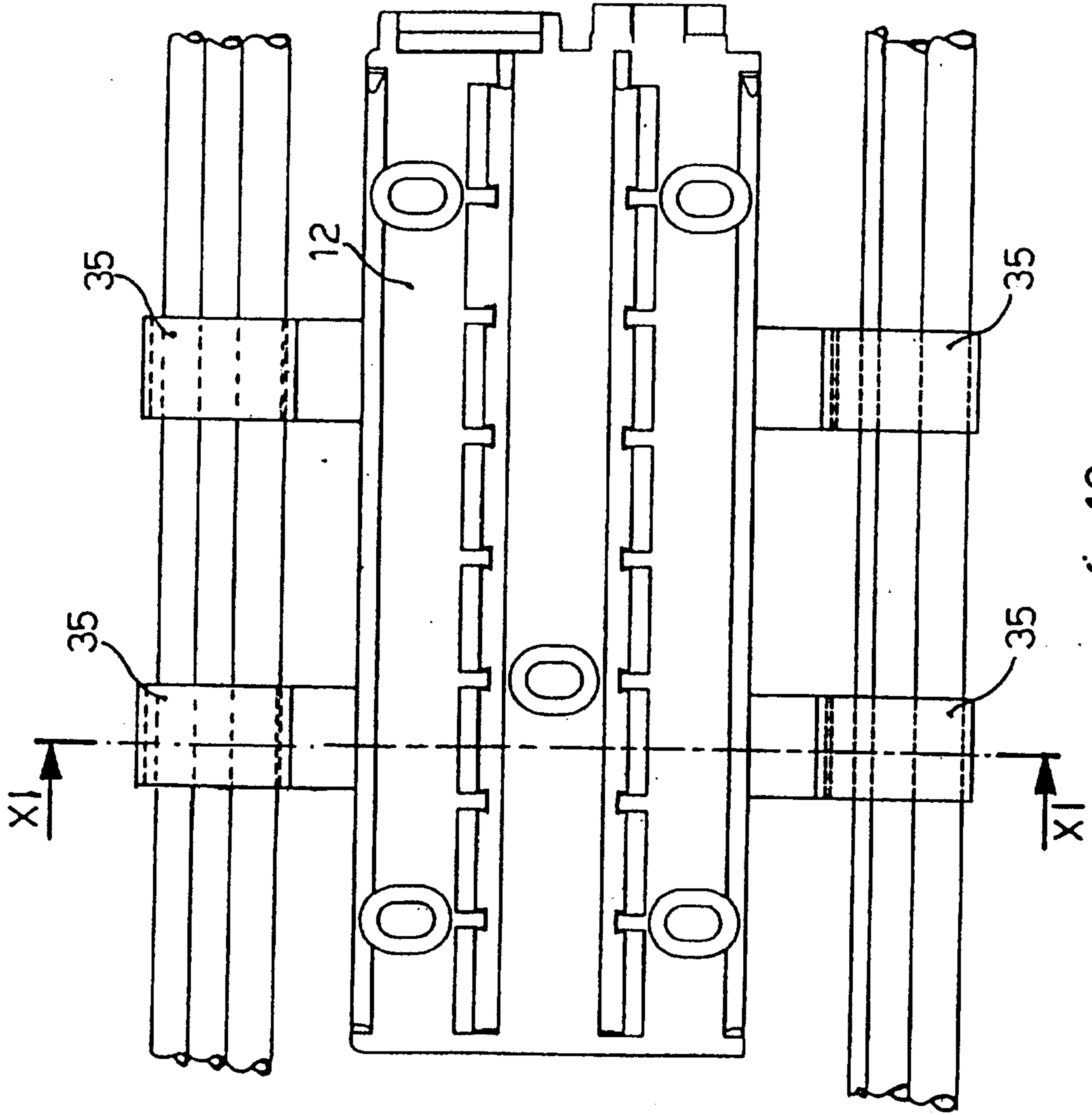

fig. 10

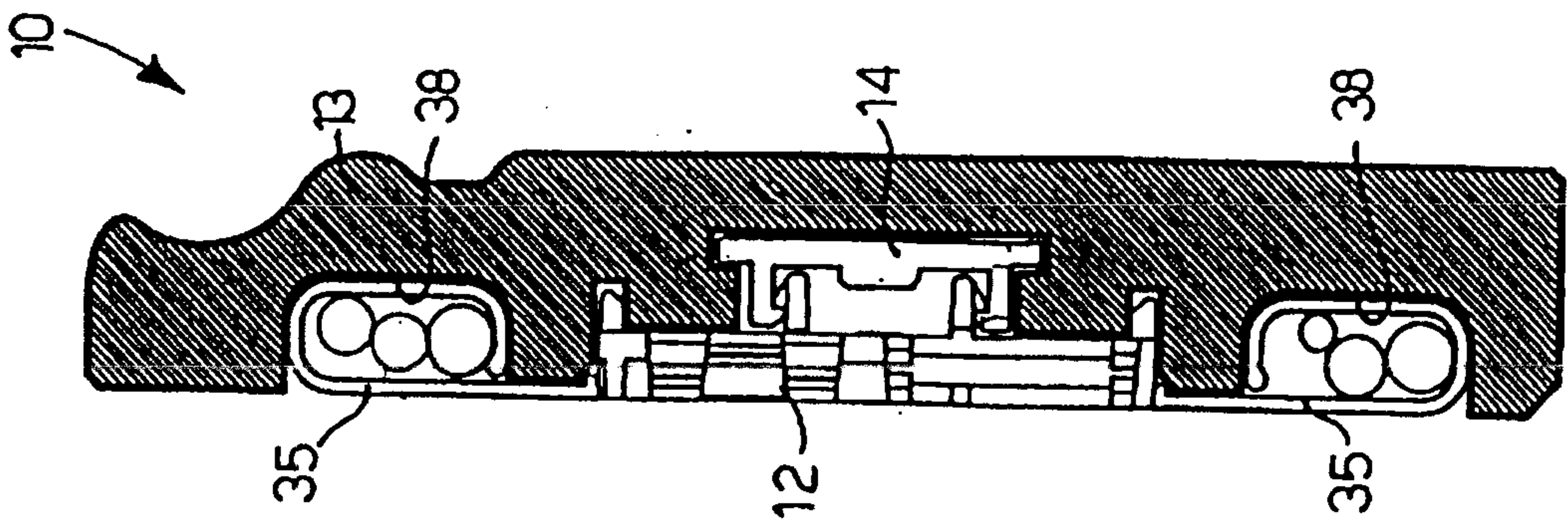

fig. 9

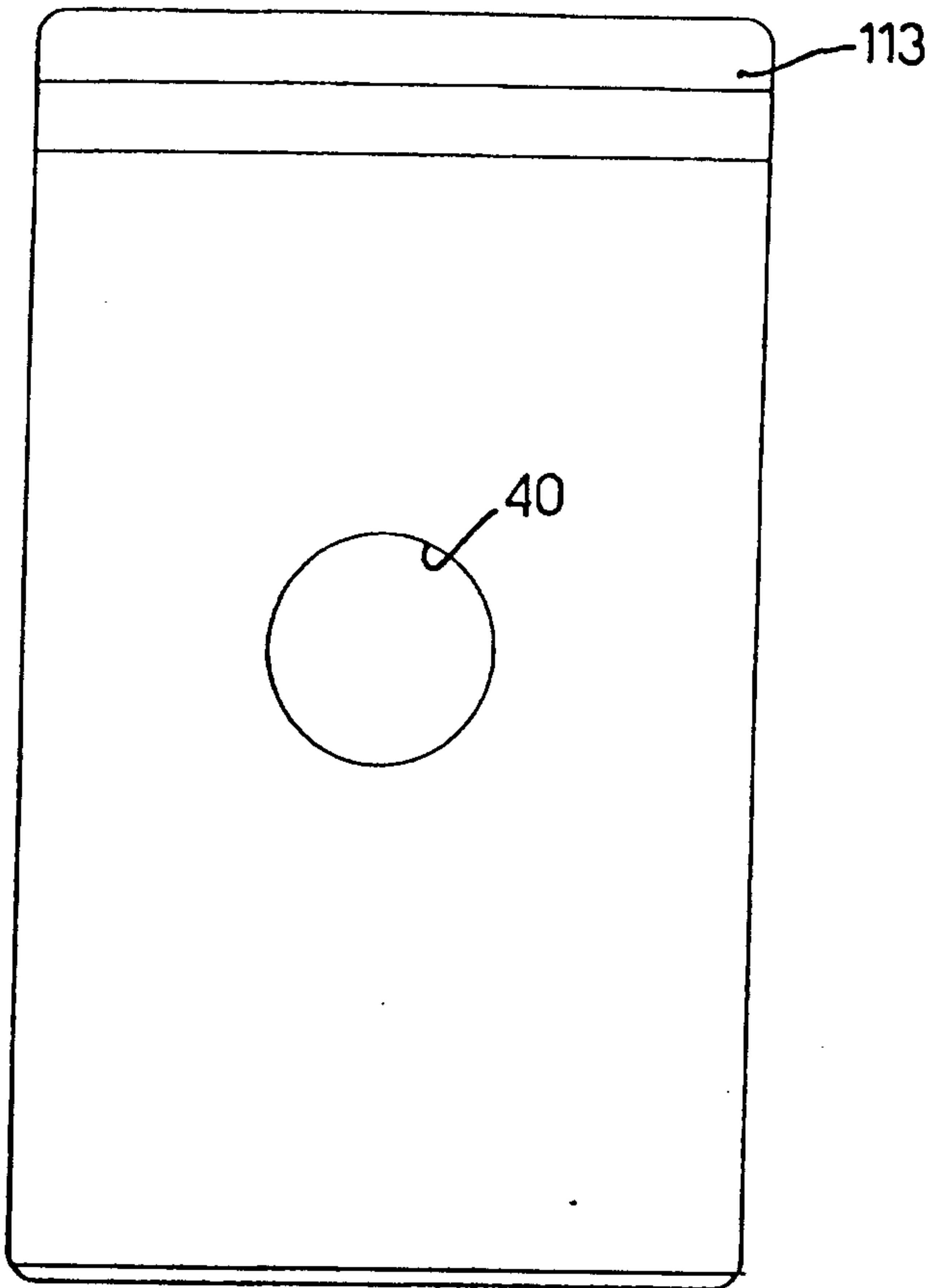

fig. 12

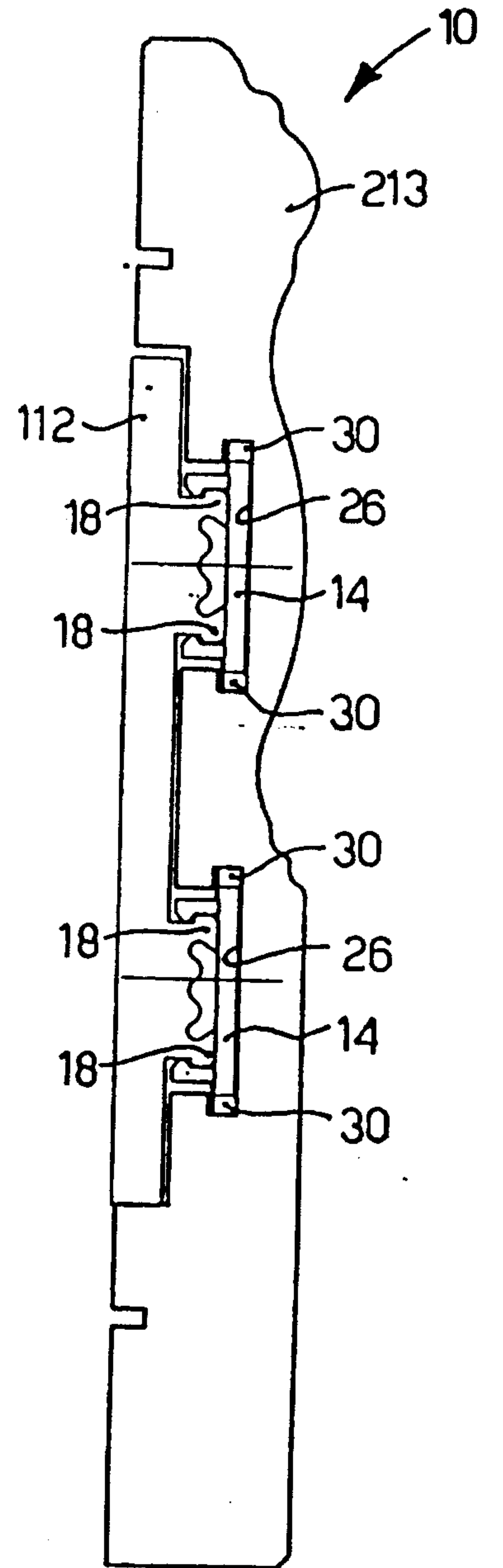

fig. 13

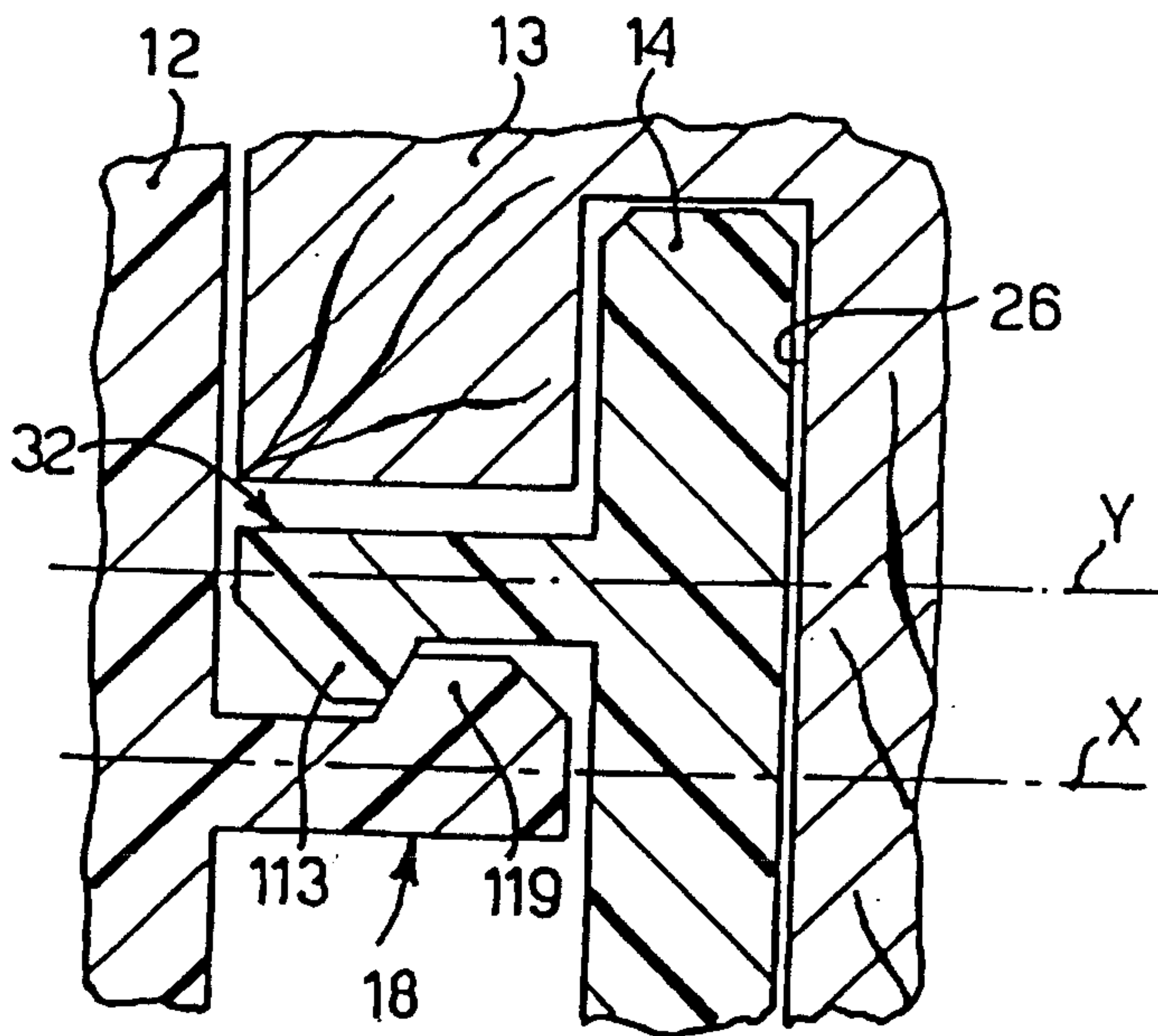

fig. 14

