

(No Model.)

3 Sheets—Sheet 1.

G. E. WARNKE.
PNEUMATIC STRAW STACKER.

No. 526,423.

Patented Sept. 25, 1894.

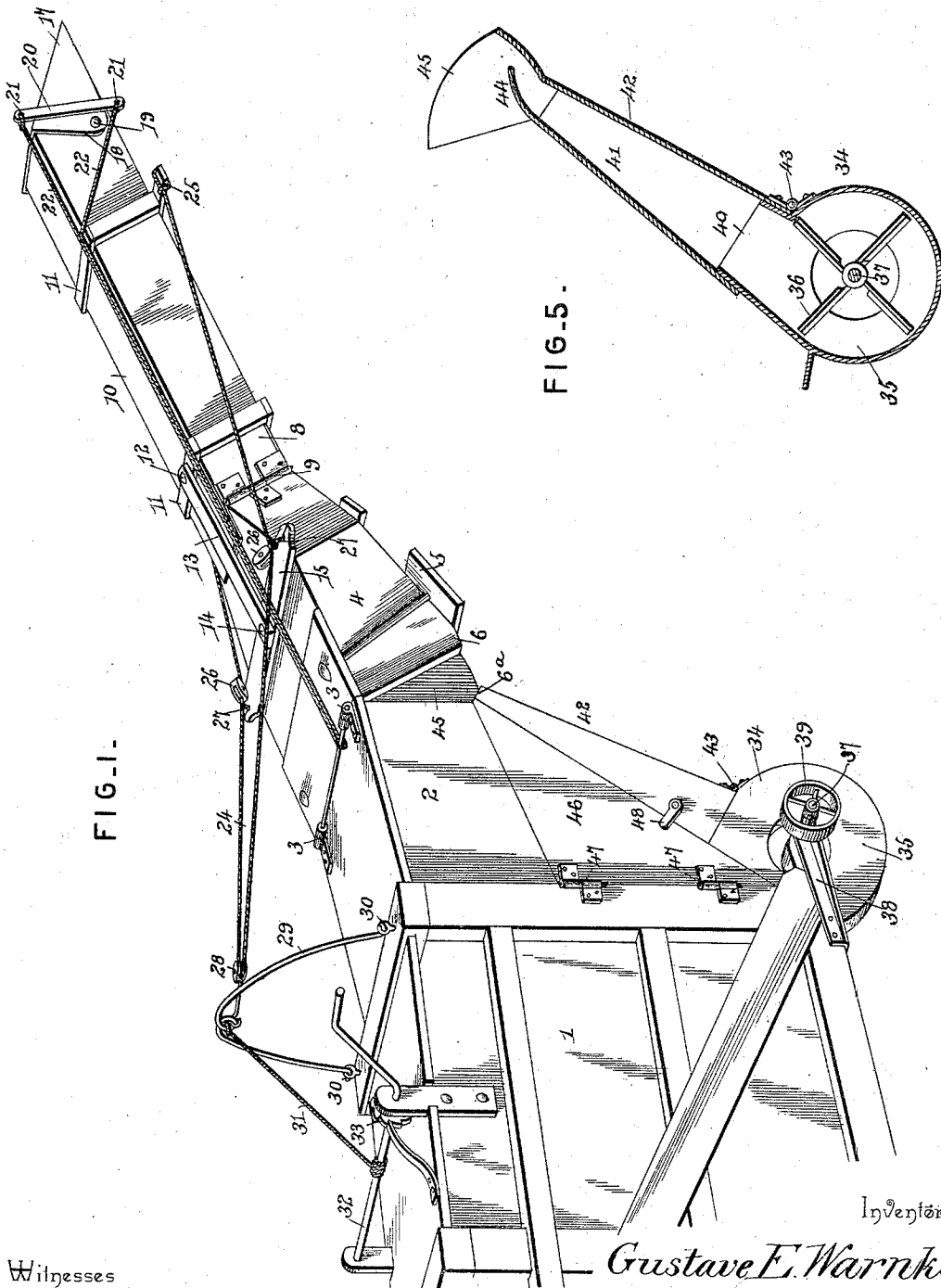

FIG. 1.

FIG. 5.

Inventor

Gustave E. Warnke

By His Attorneys.

Witnesses

Jas. K. McLaughlin
S. P. Halhaupter.

C. A. Snow & Co.

(No Model.)

3 Sheets—Sheet 2.

G. E. WARNKE.
PNEUMATIC STRAW STACKER.

No. 526,423.

Patented Sept. 25, 1894.

FIG. 2.-

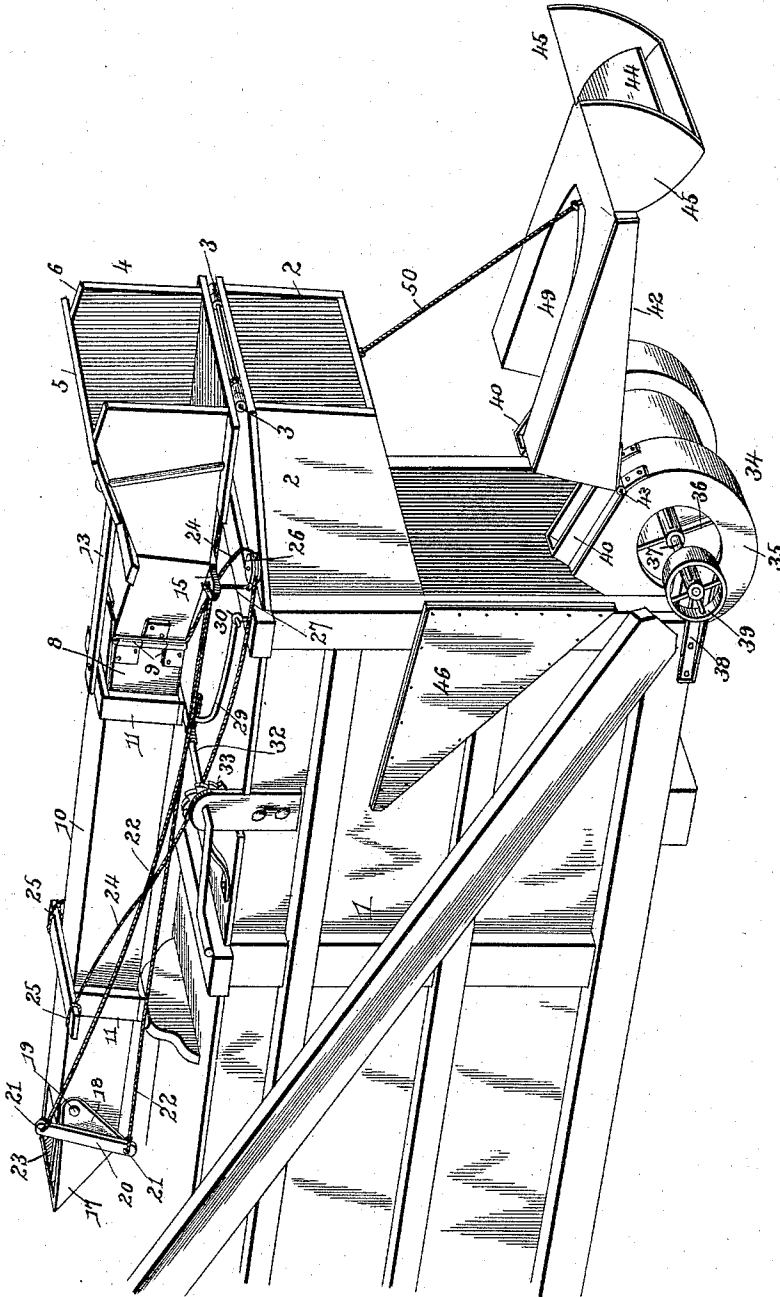

Inventor

Gustave E. Warnke

Witnesses

Jas. K. McCracken
D. P. Hochhauser

By *his* Attorneys.

C. A. Snow & Co.

(No Model.)

3 Sheets—Sheet 3.

G. E. WARNKE. PNEUMATIC STRAW STACKER.

No. 526,423.

Patented Sept. 25, 1894.

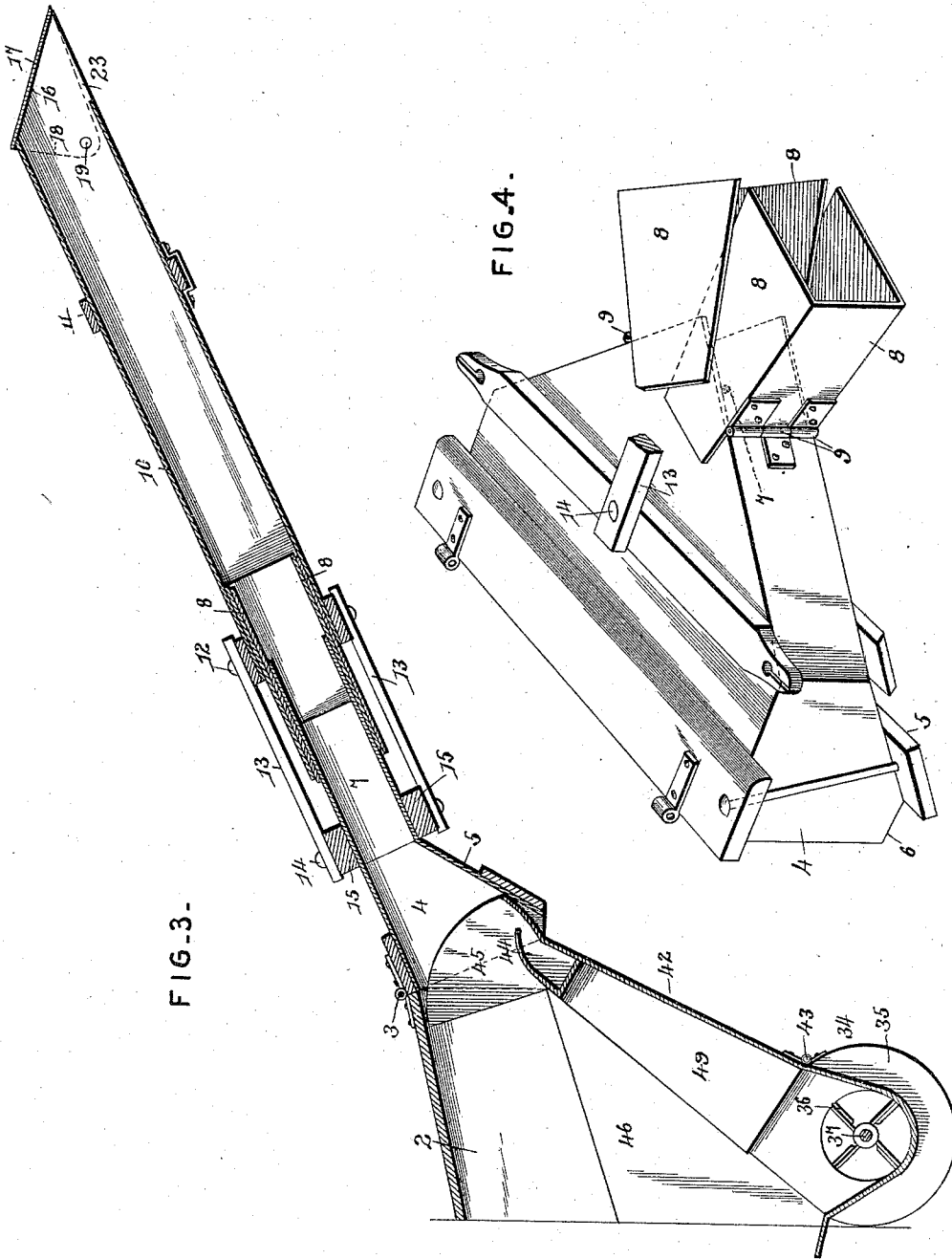

FIG. 3.

FIG. 4.

Inventor

Gustave E. Warnke

By his Attorneys.

C. Snow & Co.

Witnesses

Jas. K. McLaughlin
J. P. H. H. H. H.

UNITED STATES PATENT OFFICE.

GUSTAVE E. WARNKE, OF WOOD LAKE, MINNESOTA.

PNEUMATIC STRAW-STACKER.

SPECIFICATION forming part of Letters Patent No. 526,423, dated September 25, 1894.

Application filed April 9, 1894. Serial No. 506,905. (No model.)

To all whom it may concern:

Be it known that I, GUSTAVE E. WARNKE, a citizen of the United States, residing at Wood Lake, in the county of Yellow Medicine and State of Minnesota, have invented a new and useful Pneumatic Straw-Stacker Attachment for Thrashers, of which the following is a specification.

This invention relates to pneumatic straw stacker attachments for thrashers; and it has for its object to provide a new and useful attachment of this character that can be readily attached to the rear discharging end of an ordinary thrashing machine to provide for elevating the straw to and arranging the same on the stack.

To this end the main and primary object of the present invention is to construct a pneumatic stacker attachment which shall be provided with all necessary adjustments for evenly distributing the straw onto the stack while at the same time being capable of being folded up out of the way to provide for the easy transportation of the thrasher and also for gaining ready access to the interior working parts thereof.

With these and other objects in view which will readily appear as the nature of the invention is better understood, the same consists in the novel construction, combination and arrangement of parts hereinafter more fully described, illustrated and claimed.

In the accompanying drawings: Figure 1 is a perspective view of a portion of a thrashing machine equipped with the herein-described pneumatic stacker attachment. Fig. 2 is a similar view showing the several parts of the stacker attachment separated and folded out of the way. Fig. 3 is a central vertical longitudinal sectional view of the stacker attachment the parts being connected as in use. Fig. 4 is a detail in perspective of the conveyer box and spout plates. Fig. 5 is a detail sectional view including the connection of the air trunk and fan casing.

Referring to the accompanying drawings, 1 designates an ordinary thrashing machine provided at its upper rear end with the discharge flue 2, through which the straw from the separating devices within the thrasher is adapted to be drawn and discharged by the suction created by the suction devices to be

hereinafter more particularly described. The rear off standing discharge flue 2, of the thrashing machine, is adapted to have hinged to the upper outer edge thereof on the hinges 3, the inner upper edge of the flared conveyer box 4. By reason of the hinge connections 3, the flared conveyer box 4, may be thrown back over the top of the thrasher or adjusted in substantial alignment with the discharge flue 2, in order to receive and convey away the straw to the stack.

The flared conveyer box 4, is preferably constructed in a substantial triangular shape and consists of suitably connected top, bottom, and side pieces, and at its inner flared end the said box is provided with the inclined bottom board 5, extending to the opposite inner side shoulders 6, the function of which will be hereinafter noted, and at its outer contracted end the said conveyer box is provided with a discharge opening 7, at each side of which are hinged the overlapping forwardly projected spout plates 8.

The forwardly projecting spout plates 8, are hinged at their inner ends on the hinges 9, to directly opposite sides of the outer contracted end of the conveyer box 4, and said spout plates are of a U-shape having their top and bottom sides overlapping each other and the top and bottom sides of the flared conveyer box, so as to close in a tubular spout through which the blast of air and straw may be discharged without leaving any openings for the escape of the air or straw, while at the same time this arrangement provides for a wide simultaneous lateral movement or adjustment of these spout plates without affecting the tubular space inclosed thereby. The said overlapping spout plates 8, form a flexible tubular connection for the inner end of the conveyer spout 10, with the outer contracted end of the conveyer box 4. The conveyer spout 10, consists of a rectangular or circular tube of wood or metal provided at proper points thereon with suitable strengthening bands or rings 11, encircling the same, and the inner open end of the conveyer spout 10, loosely fits over the outer end of the flexible spout connection formed by the plates 8, and has pivotally connected to the upper and lower sides of its inner end above and below the spout plates, as at 12,

the outer ends of the upper and lower connecting link arms 13, the inner ends of which are pivoted at 14, to the upper and lower cross bars 15, attached to the upper and lower sides of the conveyer box 4, thereby completing a flexible connection for the inner end of the spout with the conveyer box, whereby the said spout may be laterally adjusted to evenly distribute the straw at different points on the stack, in order to make an even and uniform stack which is highly desirable.

The outer discharging end of the tubular conveyer spout 10, that conveys or elevates the discharged straw from the thrashing machine is provided with the opposite inclined sides 16, over which sides is arranged to work the U-shaped spout cap 17, the opposite side flanges 18, of which are pivoted at their inner ends on the pivots 19, to opposite sides of the outer end of the conveyer spout, and to one side of the spout cap 18, is attached the operating arm 20, extending above and below the same and provided with upper and lower perforated ends 21, to which are connected the outer ends of the adjusting cord 22, which leads to a convenient point at the inner end of the conveyer such as at the hinge 3, of the conveyer box 4, so as to be conveniently and readily controlled by the operator for raising and lowering the cap according to the height of the stack or the point to where it is desired to discharge the straw. When closed down onto the opposite inclined sides 16, at the outer end of the conveyer spout, the spout cap 17, closes in the outer end of the spout and serves as a deflector to discharge the straw through the outer bottom discharge opening 23, formed between the projected outer inclined sides of the conveyer, and the spout is worked with the cap in this position when the stack is first started, or reaches a height where it is not convenient to expel the straw out through the conveyer box in a direct line with the disposition thereof.

The conveyer spout 10, by reason of the connections 3 and 8, is capable of a vertical and lateral or swing adjustment, and to secure this adjustment the opposite side adjustment cords or ropes 24 are connected at their outer ends, as at 25, to opposite sides of the conveyer spout near its outer end, and said opposite side guide pulleys 26, that are flexibly connected by the connections 27 to opposite extremities of the upper one of the cross bars 15, and the inner portion of the adjusting cords 24 passes loosely through the adjusting pulley 28, connected to the upper end of the swinging adjusting bail 29. The swinging adjusting bail 29, is substantially U-shaped and is pivotally connected at its extremities, as at 30, to the top rear end of the thrashing machine, and a main adjusting cord or rope 31, is connected at its upper end to the upper end of the bail 29, and winds and unwinds at its other end on the windlass

32, journaled on top of the thrashing machine and provided with a pawl and ratchet check device 33 to provide for holding the conveyer spout in any adjusted position. By manipulating the windlass 32, the conveyer spout may be raised and lowered to secure the proper vertical adjustment thereof, and by reason of the side cords 24, and the pulley supports 26 and 28, therefor, the conveyer spout may also be easily swung sidewise in order to secure the proper lateral adjustment of the spout, and therefore the proper distribution of the straw onto the stack.

In connection with the herein-described attachment a casing frame 34, is adapted to be suitably secured in a stationary position at the rear lower end of the thrashing machine, and said casing frame is provided at opposite ends or sides thereof with the opposite circular fan casings 35, in which are arranged the blast fans 36, mounted on the transverse fan shaft 37, journaled at its opposite ends in bearing brackets 38, secured to opposite sides of the thrashing machine, and carrying at one end a band wheel or pulley 39, to receive a belt for transmitting motion to the fan. The opposite fan casings 35, are provided at their upper sides with the off-standing rectangular or tubular discharge neck 40, over which are adapted to removably fit the opposite tubular air spouts 41, of the double air trunk 42.

The double air-trunk 42, is hinged at its inner lower edge at 43, to one edge of the casing frame 34, so that the trunk may be raised and lowered to its operative and inoperative positions, and said air trunk mainly comprises the opposite tubular air spouts 41, that are tapered toward their upper discharging ends, and communicate at their upper ends with the upper transverse distributing trunk portion 44. The upper transverse distributing trunk portion 44 projects at a slight angle off from the upper ends of the air spouts 41, and is provided at opposite sides thereof with the upwardly disposed joint flanges 45, that are adapted to be received within opposite inner sides of the conveyer box 4, to close in the opposite side joints between the same and the thrasher discharge tube 2, as the conveyer spout is being adjusted up and down.

In operation, the air trunk 42, is adjusted up against the under side of the discharge flue 2, with the distributing trunk portion 44 projecting beyond the flue so as to be received within, and to fit on the inclined bottom board, 5, of the conveyer box 4, when the same is adjusted down over the outer end of the flue 2, thereby providing a connection with the air blast that discharges into the conveyer box, and therefore sucks in the straw from the thrashing machine and discharges it out through the conveyer box. This connection does not interfere with the vertical adjustment of the conveyer box, which when in its lowest adjusted position is adapted to have the inner side shoulders 6, thereof rest on the corresponding

upper outer side shoulders 6^a, formed at the upper outer ends of the air trunk. When adjusted to its upright position in connection with the conveyer box 4, the air trunk does not completely close in the space at the rear end of the thrasher under the flue 2, and to provide for closing in this space, the opposite triangular side wings 46, are employed. The side wings 46 are hinged at their inner edges, as at 47, to opposite sides of the thrashing machine, and are adapted to fit close against the opposite sides of the trunk 42, and the flue 2, and are retained in position by the turn buckles 48, pivoted to opposite sides of the trunk 42, for engagement with the outer edges of said side wings. These side wings 46, serve together with the trunk 42, to entirely close in the rear end of the thrashing machine so as to leave a free communication with the interior of the fan casing through the collector recess 49. The recess 49 is formed in the inner side of the air trunk and the casing frame 34 and opens into the inner inlets of the fans, in order to admit of the fans collecting and discharging accumulations of chaff and dust so as to relieve the interior of the machine therefrom.

When not in use the several parts of the apparatus are disconnected as shown in Fig. 2, of the drawings, the conveyer spout and box being folded back over the thrashing machine, the side wings folded against the opposite sides of the machine, and the air trunk lowered out of engagement with the fan casings, in which lowered position the trunk is supported by the stop cord 50, secured thereto and to the under side of the flue 2.

Changes in the form, proportion and the minor details of construction may be resorted to without departing from the principle or sacrificing any of the advantages of this invention.

Having thus described the invention, what is claimed, and desired to be secured by Letters Patent, is—

1. In a pneumatic straw stacker, the combination of an adjustable conveyer spout adapted to be connected with an ordinary thrashing machine, a fan, and a hinged air trunk adapted to separably connect said fan with the conveyer spout, substantially as set forth.

2. In a pneumatic straw stacker, the combination of a conveyer spout supported for vertical and horizontal adjustment, a pair of suitably arranged fans, and a double air trunk connecting said fans and having opposite tubular air spouts adapted to connect with the fans, and an upper transverse distributing trunk portion adapted to loosely fit within said conveyer spout, substantially as set forth.

3. In a pneumatic straw stacker attachment for thrashers; an elongated conveyer spout adapted to be adjustably connected with the rear discharging end of a thrashing machine, means for vertically and laterally adjusting said spout, a blast fan, and an adjustable air

trunk hinged to said fan and adapted to loosely connect at its upper end with the conveyer spout, substantially as set forth. 70

4. In an attachment for thrashing machines, an elongated closed conveyer spout provided with a conveyer box having a hinge connection with the inner end thereof and adapted to be also hinged to one end of a thrashing machine, a suitably arranged fan, and an air conveying trunk hinged to said fan and adapted to loosely project into said conveyer box, substantially as set forth. 75

5. In a pneumatic straw stacker attachment, a flared conveyer box adapted to be hinged to the rear discharging end of a thrashing machine, an elongated laterally adjustable conveyer spout, a sectional tubular spout connection between the inner end of the conveyer spout and the outer end of the conveyer box to provide for the lateral adjustment of the former, and a suitably arranged air blast discharging into said conveyer box, substantially as set forth. 80 85

6. In a pneumatic straw stacker attachment, a flared conveyer box adapted to be hinged to the rear discharging end of a thrashing machine, U-shaped overlapping spout plates hinged to opposite sides of the conveyer box at the outer end thereof, an elongated closed conveyer spout loosely fitted at its inner end over said spout plates, and a suitable blast discharging into said conveyer box, substantially as set forth. 90 95

7. In a pneumatic straw stacker attachment, the combination with the rear discharge flue of a thrashing machine, of a flared conveyer box adapted to be hinged to said discharge flue, forwardly projecting and overlapping U-shaped spout plates hinged at their inner ends to opposite sides of the conveyer box at the outer end thereof, an elongated closed conveyer spout loosely fitted at its inner end over said spout plates, upper and lower link arms pivotally connected to the upper and lower sides of the conveyer box and to the inner end of said conveyer spout, an adjustable spout cap for the outer end of the spout, a suitably arranged air blast discharging into said conveyer box, and means for adjusting the conveyer box and the spout, substantially as set forth. 100 105 110 115

8. In a pneumatic straw stacker attachment the combination with the rear discharge flue of a thrashing machine; of a conveyer box adapted to be hinged to said discharge flue, a laterally adjustable conveyer spout hinged at its inner end to the conveyer box for lateral adjustment, a swinging adjusting bail adapted to be arranged at a convenient point in rear of the conveyer box, means for adjusting said bail, pulleys flexibly connected to the upper end of said bail and to upper opposite sides of the conveyer box, opposite side adjustment cords or ropes passed around said pulleys and connected to opposite sides of the spout near its outer end, and a suitably arranged air blast adapted to discharge 120 125 130

into said conveyer box, substantially as set forth.

9. In a pneumatic straw stacker attachment, the combination with a suitably arranged air blast; of a vertically and laterally adjustable closed conveyer spout provided with opposite inclined sides at its outer end, a U-shaped spout cap pivotally supported at the outer end of the spout and arranged to work over said inclined sides, and means for opening and closing the spout cap, substantially as set forth.

10. In a pneumatic straw stacker attachment, the combination of an adjustable conveyer spout having a flared conveyer box at its inner end adapted to be hinged to the discharging end of a thrashing machine and provided with an inclined bottom board, oppositely arranged stationary fan casings having off-standing discharge necks, and a double air trunk hinged at one edge to said fan casings and comprising opposite tubular air spouts adapted to fit over the casing discharge necks, an upper transverse distributing trunk portion disposed at an angle to loosely engage within said conveyer box on its inclined bottom board, and opposite upwardly disposed joint flange adapted to be received within opposite inner sides of the conveyer box, substantially as set forth.

11. In a pneumatic straw stacker attach-

ment, the combination with the rear discharge flue of a thrashing machine; of a conveyer spout adapted to be adjustably connected with said discharge flue, a stationary fan casing, an adjustable air trunk hinged to said fan casing and arranged to be adjusted under said discharge flue and to project into the inner end of the conveyer spout, and side wings adapted to be hinged to opposite sides of the thrashing machine and to be folded against the outer sides of the air trunk and said discharge flue, substantially as set forth.

12. In a pneumatic straw stacker, a closed conveyer box adapted to be hinged to the discharging end of a thrashing machine, an elongated closed conveyer spout loosely connected to said conveyer box and communicating therewith, a fan casing, a double fan, and a double air trunk adapted to connect the fans with the conveyer box, and provided at its inner side with a collector recess communicating with the fans, substantially as set forth.

In testimony that I claim the foregoing as my own I have hereto affixed my signature in the presence of two witnesses.

GUSTAVE E. WARNKE.

Witnesses:

HENRY WERNER,
H. E. HOUSTON.