

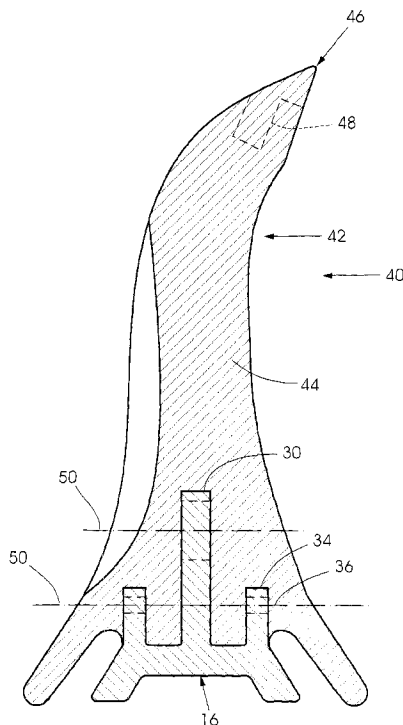

(86) Date de dépôt PCT/PCT Filing Date: 2016/06/14
 (87) Date publication PCT/PCT Publication Date: 2017/02/09
 (45) Date de délivrance/Issue Date: 2020/11/10
 (85) Entrée phase nationale/National Entry: 2018/02/02
 (86) N° demande PCT/PCT Application No.: ZA 2016/050020
 (87) N° publication PCT/PCT Publication No.: 2017/024324
 (30) Priorité/Priority: 2015/08/04 (ZA2015/05594)

(51) Cl.Int./Int.Cl. *B65G 45/12* (2006.01)
 (72) Inventeur/Inventor:
CHRISTIAN, PAUL, ZA
 (73) Propriétaire/Owner:
BRELKO PATENTS (PTY) LTD, ZA
 (74) Agent: GOWLING WLG (CANADA) LLP

(54) Titre : BASE POUR RACLOIR DE COURROIE TRANSPORTEUSE
 (54) Title: BASE FOR CONVEYOR BELT SCRAPER



(57) **Abrégé/Abstract:**

A conveyor belt scraper (40) which includes a base (10) and a scraper element (42) which is moulded to the base (10).

(12) INTERNATIONAL APPLICATION PUBLISHED UNDER THE PATENT COOPERATION TREATY (PCT)

(19) World Intellectual Property
Organization
International Bureau(10) International Publication Number
WO 2017/024324 A1(43) International Publication Date
9 February 2017 (09.02.2017)

- (51) International Patent Classification: *B65G 45/12* (2006.01)
- (21) International Application Number: PCT/ZA2016/050020
- (22) International Filing Date: 14 June 2016 (14.06.2016)
- (25) Filing Language: English
- (26) Publication Language: English
- (30) Priority Data: 2015/05594 4 August 2015 (04.08.2015) ZA
- (71) Applicant: **BRELKO PATENTS (PTY) LTD** [ZA/ZA]; No. 16 Harries Street, Reuven Extension 1, Booysens, 2091 Johannesburg (ZA).
- (72) Inventor: **CHRISTIAN, Paul**; c/o 16 Harries Street, Reuven Extension 1, Booysens, 2091 Johannesburg (ZA).
- (74) Agents: **MCCALLUM RADEMEYER & FREIMOND** et al.; 390 Kent Avenue, Ferndale (P.O. Box 1130, Randburg), 2125 Johannesburg (ZA).
- (81) Designated States (unless otherwise indicated, for every kind of national protection available): AE, AG, AL, AM, AO, AT, AU, AZ, BA, BB, BG, BH, BN, BR, BW, BY, BZ, CA, CH, CL, CN, CO, CR, CU, CZ, DE, DK, DM, DO, DZ, EC, EE, EG, ES, FI, GB, GD, GE, GH, GM, GT, HN, HR, HU, ID, IL, IN, IR, IS, JP, KE, KG, KN, KP, KR,

[Continued on next page]

(54) Title: BASE FOR CONVEYOR BELT SCRAPER

(57) Abstract: A conveyor belt scraper (40) which includes a base (10) and a scraper element (42) which is moulded to the base (10).

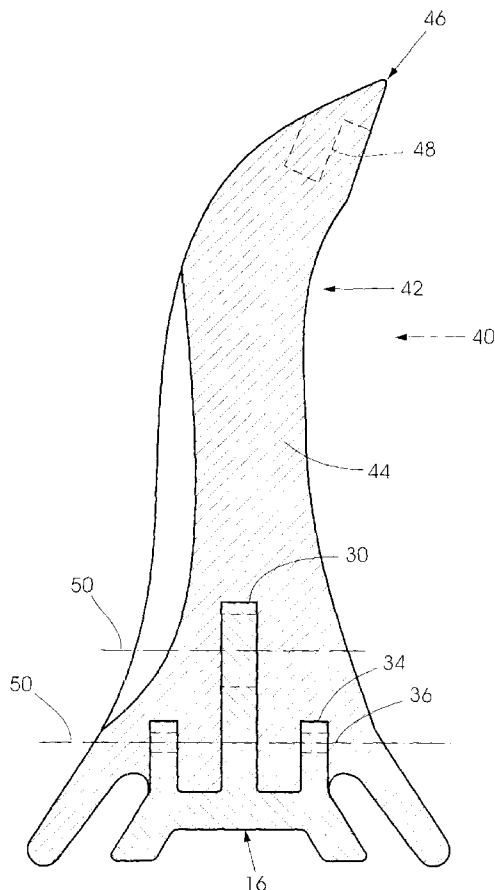

FIGURE 3

 WO 2017/024324 A1

WO 2017/024324 A1 

KZ, LA, LC, LK, LR, LS, LU, LY, MA, MD, ME, MG, MK, MN, MW, MX, MY, MZ, NA, NG, NI, NO, NZ, OM, PA, PE, PG, PH, PL, PT, QA, RO, RS, RU, RW, SA, SC, SD, SE, SG, SK, SL, SM, ST, SV, SY, TH, TJ, TM, TN, TR, TT, TZ, UA, UG, US, UZ, VC, VN, ZA, ZM, ZW.

DK, EE, ES, FI, FR, GB, GR, HR, HU, IE, IS, IT, LT, LU, LV, MC, MK, MT, NL, NO, PL, PT, RO, RS, SE, SI, SK, SM, TR), OAPI (BF, BJ, CF, CG, CI, CM, GA, GN, GQ, GW, KM, ML, MR, NE, SN, TD, TG).

Published:

(84) Designated States (unless otherwise indicated, for every kind of regional protection available): ARIPO (BW, GH, GM, KE, LR, LS, MW, MZ, NA, RW, SD, SL, ST, SZ, TZ, UG, ZM, ZW), Eurasian (AM, AZ, BY, KG, KZ, RU, TJ, TM), European (AL, AT, BE, BG, CH, CY, CZ, DE,

- with international search report (Art. 21(3))
- before the expiration of the time limit for amending the claims and to be republished in the event of receipt of amendments (Rule 48.2(h))

BASE FOR CONVEYOR BELT SCRAPERBACKGROUND OF THE INVENTION

[0001] This invention relates generally to a conveyor belt scraper and more particularly to a base for use with a conveyor belt scraper.

5 [0002] One type of conveyor belt scraper is made from a tough, resiliently deformable, material such as polyurethane. Typically, this type of belt scraper, which is integrally moulded, has a retention formation which is engageable with a sliding action with a suitable channel in a holder. Some properties which make polyurethane suitable for use as a scraper can however, present problems during installation and recovery of the scraper, when worn. This is because the
10 polyurethane is "sticky" and tends to cling to a holder, resisting relative sliding movement.

[0003] Another type of scraper has a base which is square in cross-section and which is positioned inside a tubular holder which is also of square cross-section. There is an offset between the base and the holder so that, inside the holder, four triangular voids are formed at respective corners of the holder. Each void is occupied by a compressible rubber insert. The
15 positioning of each rubber insert can be arduous for, usually, it is necessary to freeze each insert, using liquid nitrogen, so that the insert can be placed in position. The use of liquid nitrogen is expensive, and assembly of the base requires a fair amount of labour.

[0004] An object of the present invention is to address, at least to some extent, the aforementioned factors.

SUMMARY OF THE INVENTION

[0005] The invention provides a base for a conveyor belt scraper, wherein the base has an elongate body of uniform cross-section which includes a bridging piece with a first side and a second side which is opposed to the first side, first and second spaced apart legs on the first side of the bridging piece and at least two spaced apart retention sections on the second side of the bridging piece.

[0006] Each retention section may, in cross-section, be of rectangular form. This is preferred but non-limiting. The retention sections may differ in size or shape. A first retention section on the second side of the bridging piece may be flanked by second and third retention sections which are respectively spaced from the first retention section and which extend from the second side. The second and third retention sections may be smaller than the first retention section.

[0007] At least one retention section may include a number of keying formations. In one form of the invention each keying formation is a respective hole which extends through the retention section. Alternatively each keying formation may respectively comprise a recess in, or an enlarged portion of, the retention section. The invention is not limited in this respect.

[0008] The keying formations may be adapted to bond to a material which, in use, is moulded to the body.

[0009] The body may be made from a suitable material, e.g. a hard material which allows the base to be slid into engagement with a holder, or to be slid out of engagement with a holder, with relative ease. The body may, for example, be made from a non-ferrous material (to counter the effects of corrosion) or from a plastics material, e.g. a suitable nylon which is reinforced with glass or the like. This is exemplary only and non-limiting.

[0010] The body may be formed from an elongate extrusion which is cut, as appropriate, to a suitable length. Alternatively the body may be formed in a moulding or other process.

[0011] If the keying formations are holes then these may be formed in a drilling or punching step or the like.

5 [0012] The invention further extends to a conveyor belt scraper which includes a base of the aforementioned kind and, fixed to the body of the base, and thereby adhering to the body, a scraper element which comprises a scraper member which terminates in a scraping end or which has provision for a scraping blade to be attached to it.

[0013] The scraper member may be moulded to the body.

10 [0014] The scraper member may be made from a material which is more flexible than a material (typically polyurethane) used to make the body. Preferably, the construction of the conveyor belt scraper is such that the scraper member is integrally moulded over the base so that, for all practical purposes, a conveyor belt scraper of unitary construction is provided.

[0015] In a different form of the invention the scraper member is secured to the body using
15 appropriate fasteners which engage with the scraper member and with the keying formations.

BRIEF DESCRIPTION OF THE DRAWINGS

[0016] The invention is further described, by way of example, with reference to the accompanying drawings in which:

Figure 1 is a view in cross-section of a base for a conveyor belt scraper according to the
20 invention;

Figure 2 is a perspective view of the base shown in Figure 1; and

Figure 3 illustrates in cross-section a conveyor belt scraper made using the base shown in Figure 1.

DESCRIPTION OF PREFERRED EMBODIMENT

[0017] Figure 1 and Figure 2 are a view in cross-section and a perspective view, respectively,
5 of a base 10 for a conveyor belt scraper according to the invention.

[0018] The base 10 includes a body 12 with a bridging piece 14 which has a first side 16 and a second, opposed side 18. First and second, spaced apart, diverging legs 20 and 22 respectively, which define a gap 24 between them, project from the first side 16.

[0019] Three retention sections 30, 32 and 34 respectively extend from the second side 18,
10 away from the legs 20 and 22. Each retention section, in outline as shown in Figure 2, is generally rectangular. The section 30 is centrally positioned on the second side 18 and is the largest of the three sections. The sections 32 and 34 are spaced from the section 30 and are, in effect, at respective opposed extremities of the bridging piece 14.

[0020] Each retention section is formed with a respective number of keying formations in the
15 form of holes 36 which extend transversely through the respective section. The holes 36 in the section 30 are larger than the holes 36 in the sections 32 and 34. The holes 36 are formed in any appropriate manner, e.g. by means of a drilling process. Alternatively the holes 36 can be formed during a moulding process, if the body 12 is moulded. The invention is not limited in this respect.

[0021] The body 12 can be formed in any suitable way, e.g. in a moulding process or from a suitable extrusion which is cut to length as required. The body has a length 38 (see Figure 2) which is determined to accommodate the dimensions of an existing scraper holder.

[0022] The body 12 is preferably made from a corrosion-resistant metal, or from a hard plastics material.

[0023] Figure 3 illustrates a conveyor belt scraper 40 which is made using the body 12 shown in Figures 1 and 2. The body 12 is inserted into a suitable mould and, using an injection moulding process, a scraper element 42 is formed by over-moulding a scraper member 44 onto the body 12. The member 44 typically is made from a polyurethane material which has properties which make it highly suitable for use as a scraping element. A leading edge 46 of the scraper member 44 defines a scraping surface. Alternatively, the leading edge 46 is shaped, eg. with an elongate slot 48, shown in dotted outline, to receive a scraper blade (not shown).

[0024] The material which makes up the member 44 penetrates the holes 36 during the moulding process. The scraper member 44 is thereby secured to the body 12 in a manner which ensures that, for practical purposes, the member 44 cannot be detached from the body 12. The base 10 and the scraper element 42 thereby form an integral, composite conveyor belt scraper.

[0025] In a different form of the invention a scraper element, similar to that shown in Figure 3, is attached to the body using fasteners, notionally indicated by dotted lines 50 in Figure 3 which pass through holes in the scraper member 44 which are brought into register with corresponding holes 36 in the body.

[0026] The arrangement shown in Figure 3 means that the use of the square base and holder described in the preamble hereof, and the use of liquid nitrogen to enable rubber inserts to be located into the triangular voids referred to, are not required.

CLAIMS

1. A conveyor belt scraper comprising: a base comprising an elongate body of uniform cross-section having a bridging piece with a first side and a second side opposed to the first side, first and second spaced apart legs on the first side of the bridging piece; and at least two spaced apart retention sections on the second side of the bridging piece in such that the first and second legs project from the first side and are divergent and in that the retaining formations extend from the second side, away from the legs; and a scraper element formed by over-moulding the same onto the body and over the at least two spaced apart retention sections of the body.
2. The conveyor belt scraper according to claim 1, wherein the at least two spaced apart retention sections comprise a first retention section, a second retention section, and a third retention section, and wherein the first retention section on the second side of the bridging piece is flanked by the second and third retention sections which are respectively spaced from the first retention section and which extend from the second side at respective opposed extremities of the bridging piece.
3. The conveyor belt scraper according to claim 2, wherein the second and third retention sections are shorter than the first retention section in the direction of extension from the second side.
4. The conveyor belt scraper according to claim 2, wherein only the retention sections are over-moulded by the scraper member.

5. The conveyor belt scraper according to claim 1, wherein at least one retention section includes a number of keying formations which are adapted to bond to a material used to form and being over-moulded onto the base.
6. A conveyor belt scraper comprising: a base comprising an elongate body of uniform cross-section having a bridging piece with a first side and a second side opposed to the first side, first and second spaced apart legs on the first side of the bridging piece; and a first retention section, a second retention section, and a third retention section, and wherein the first retention section on the second side of the bridging piece-is flanked by the second and third retention sections which are respectively spaced from the first retention section and which extend upward from the second side of the bridging piece; and a scraper element formed by over-moulding the same onto the body and over the first, second and third retention sections of the body, wherein at least one of said first second and third retention sections includes a number of keying formations which are adapted to bond to a material used to form the scraper element.
7. A conveyor belt scraper comprising: a base comprising an elongate body of uniform cross-section having a bridging piece with a first side and a second side opposed to the first side, first and second spaced apart legs on the first side of the bridging piece; and a first retention section, a second retention section, and a third retention section, all of which extend upward from the second side of the bridging piece; and a scraper element formed by over-moulding the same onto the body and over the first, second and third retention

sections such that no portion of any of the retention sections is exposed after the scraper element is formed.

8. The conveyor belt scraper according to claim 6, wherein the second and third retention sections are straight and entirely enclosed within the scraper after the same is formed by over-moulding.

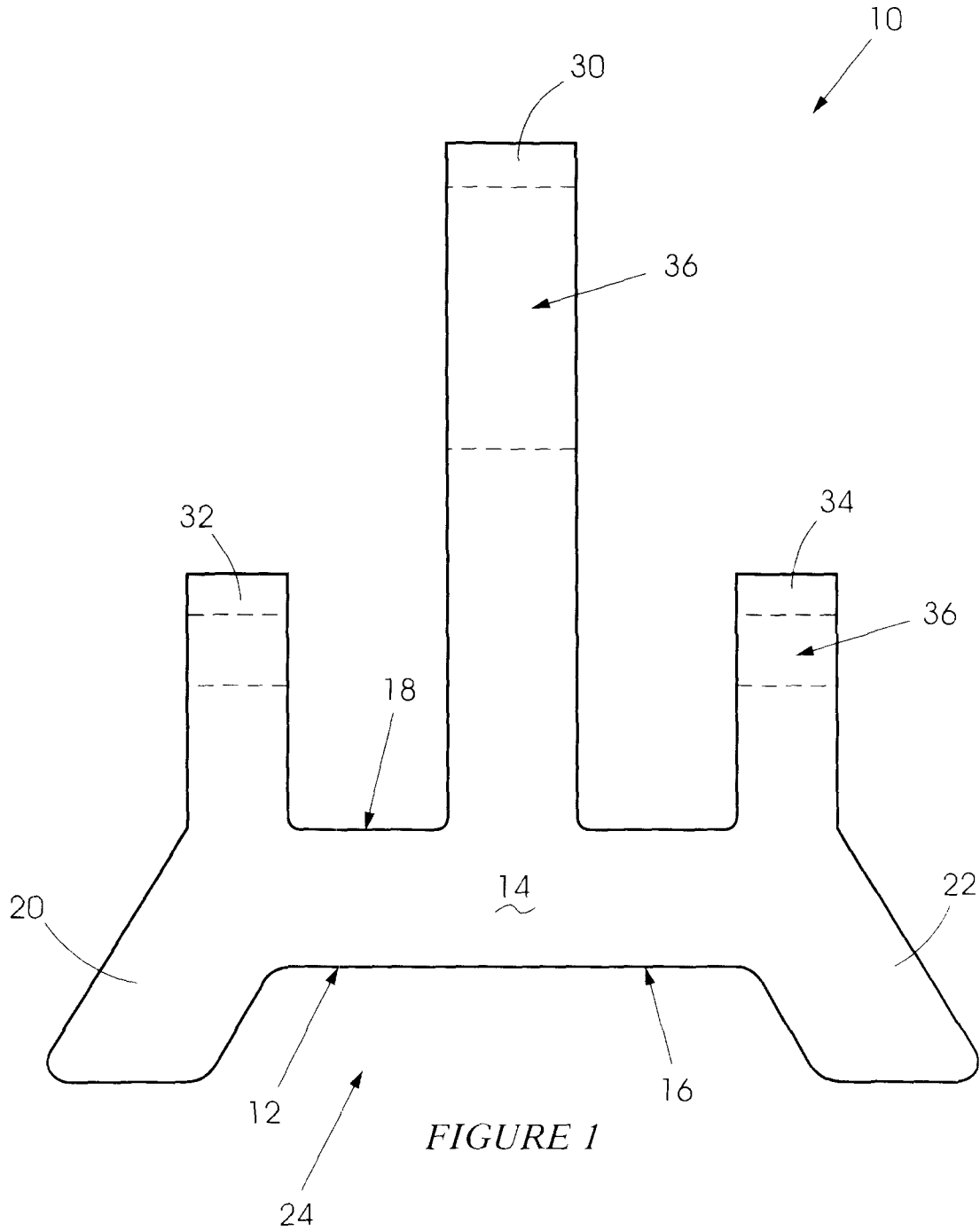

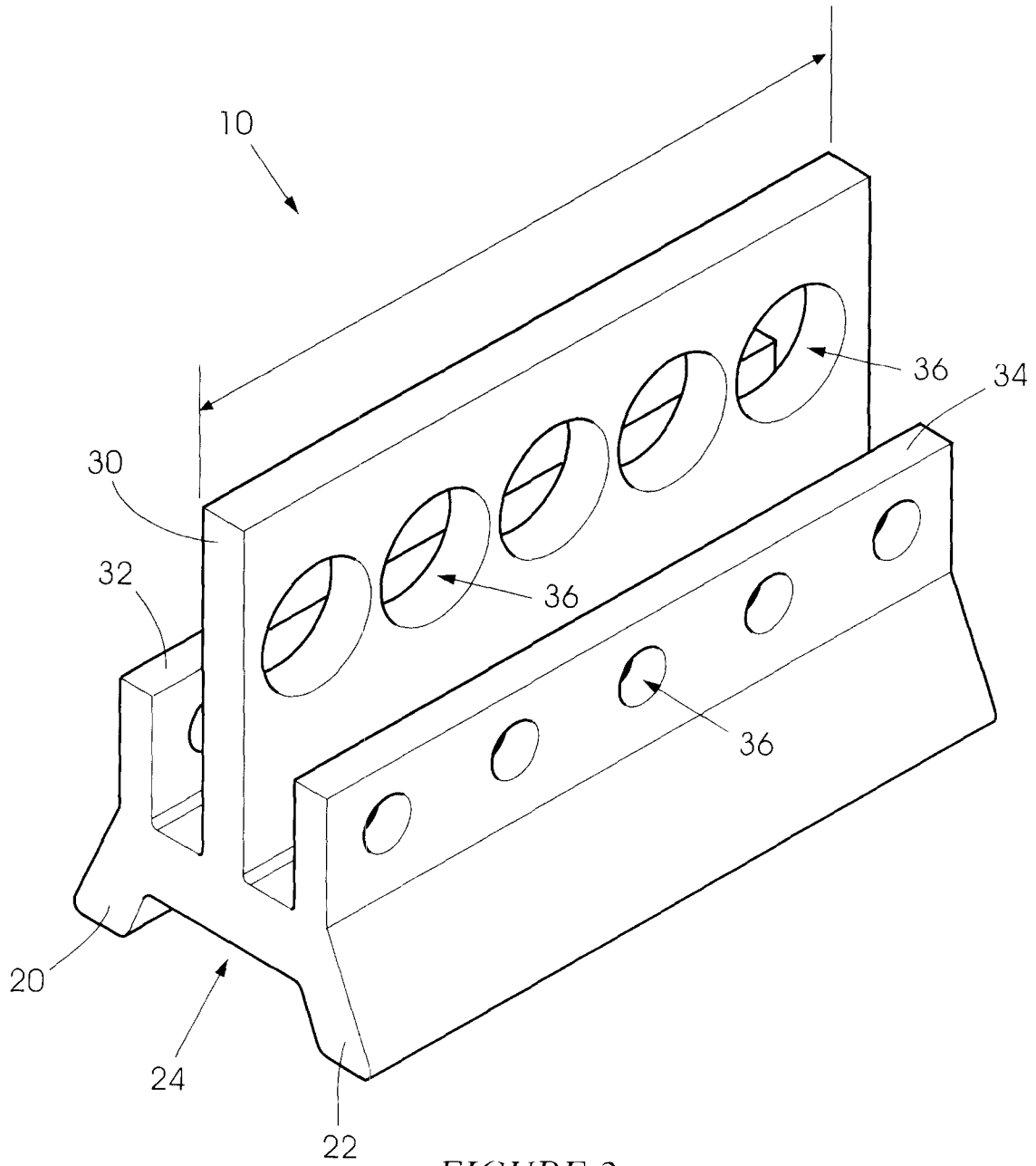

FIGURE 2

3/3

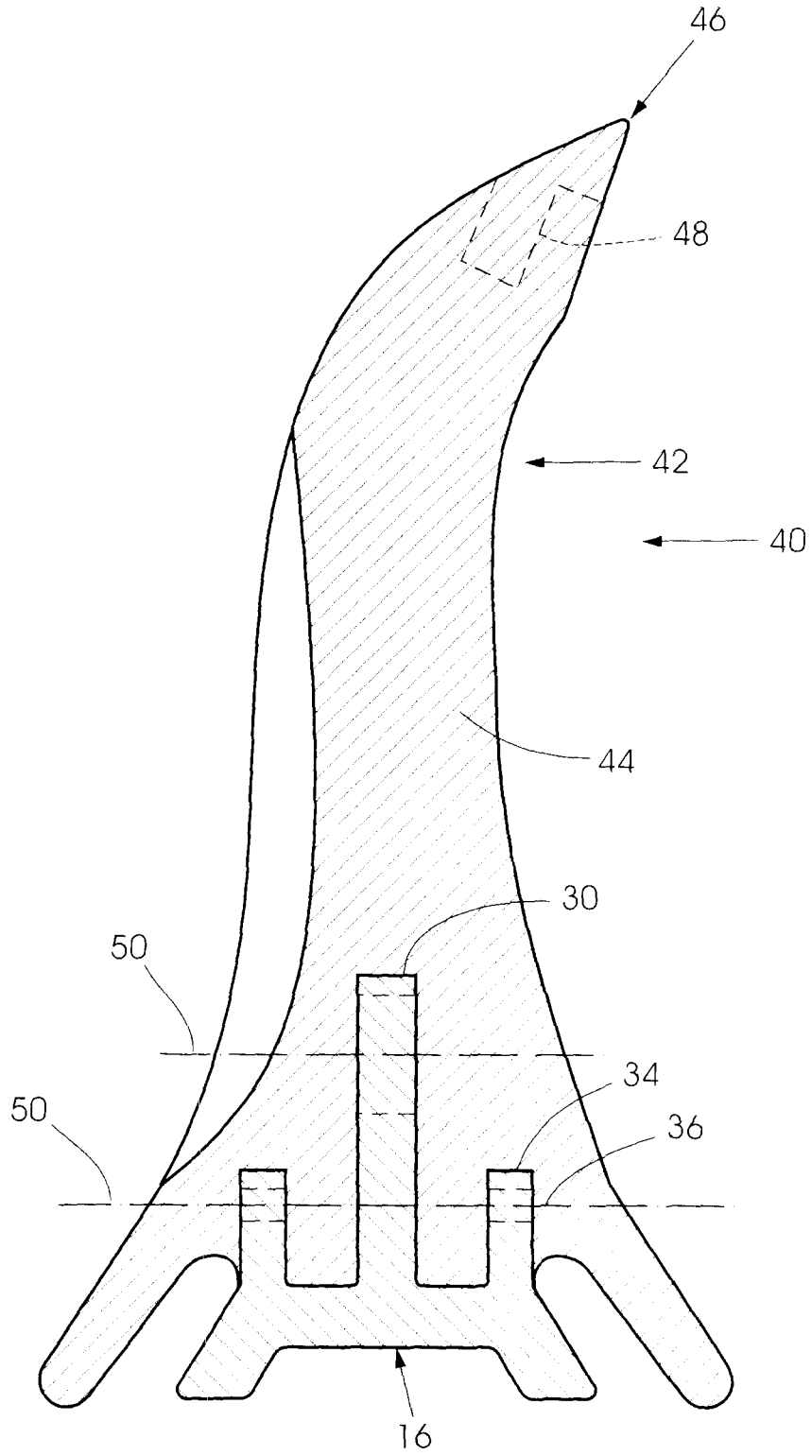

FIGURE 3

