

Aug. 8, 1961

W. HRYNISZAK

2,995,344

PLATE TYPE HEAT EXCHANGERS

Filed Feb. 12, 1959

5 Sheets-Sheet 1

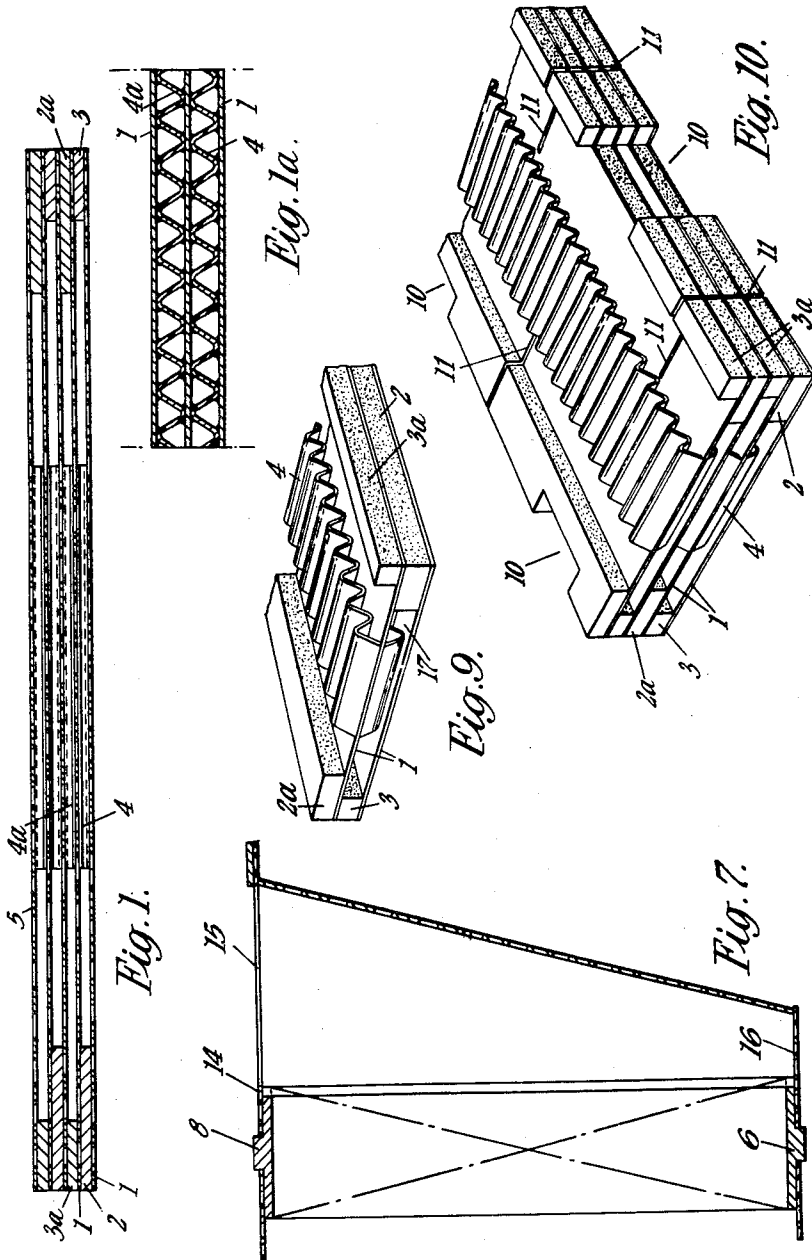

Aug. 8, 1961

W. HRYNISZAK

2,995,344

PLATE TYPE HEAT EXCHANGERS

Filed Feb. 12, 1959

5 Sheets-Sheet 2

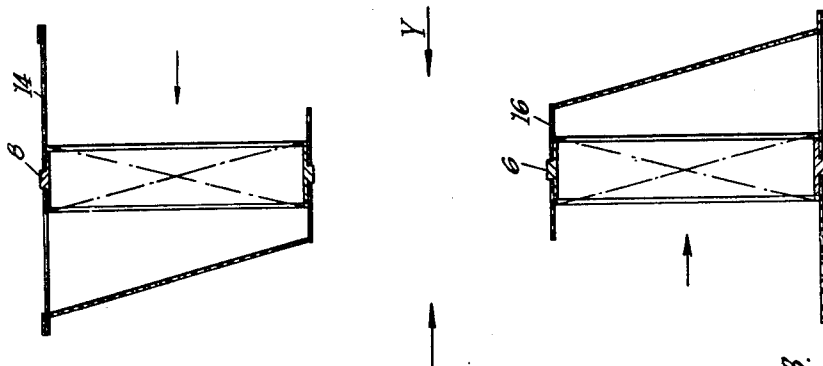

Fig. 3.

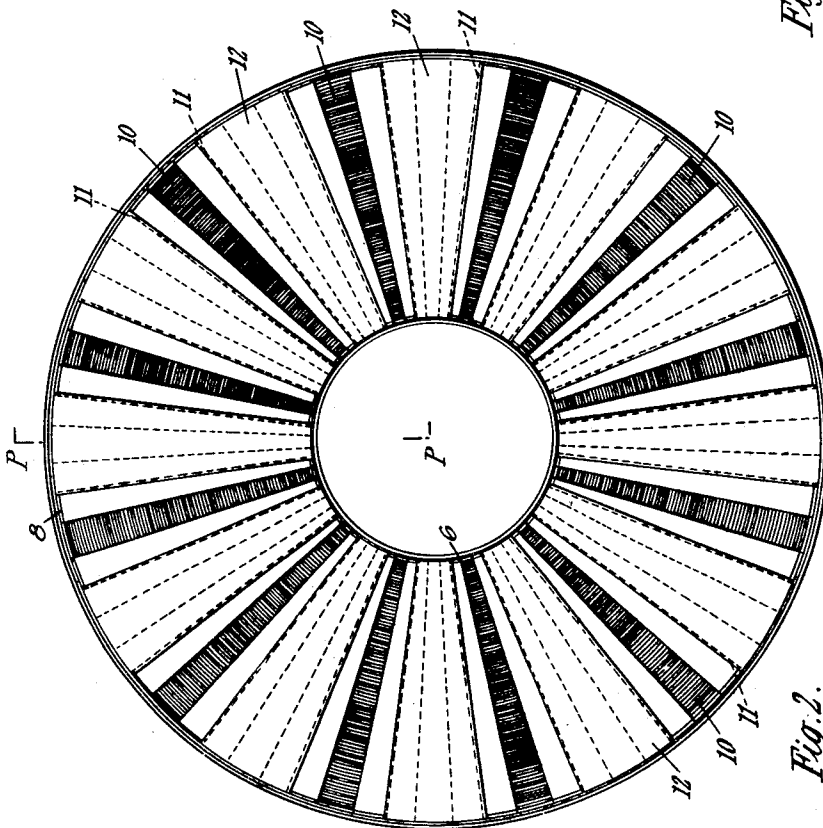

Fig. 2.

Aug. 8, 1961

W. HRYNISZAK

2,995,344

PLATE TYPE HEAT EXCHANGERS

Filed Feb. 12, 1959

5 Sheets-Sheet 3

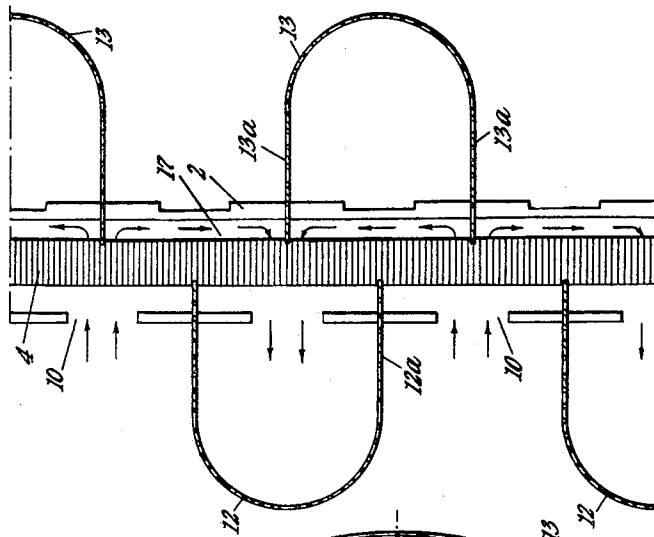

Fig. 6.

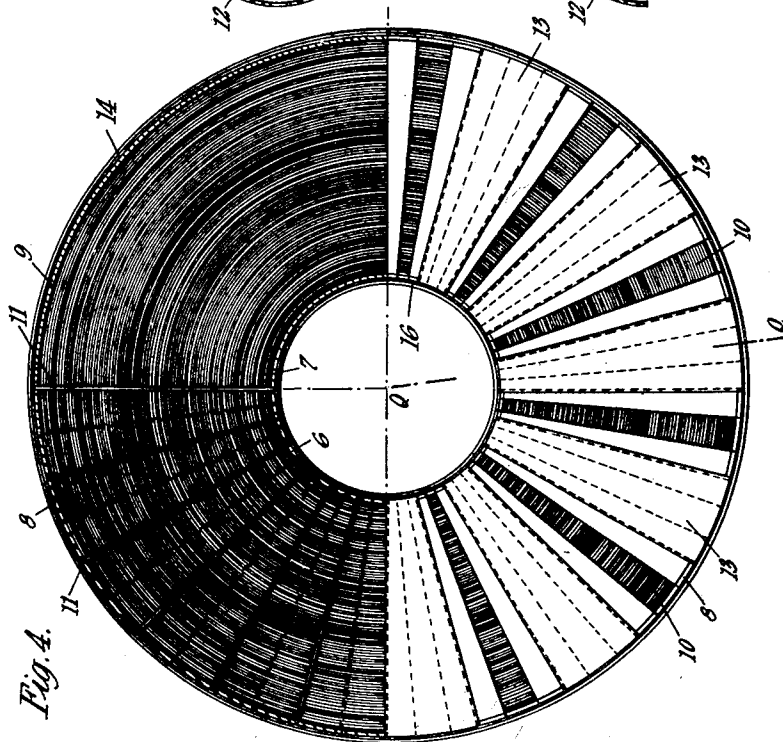

Fig. 4.

Aug. 8, 1961

W. HRYNISZAK

2,995,344

PLATE TYPE HEAT EXCHANGERS

Filed Feb. 12, 1959

5 Sheets-Sheet 4

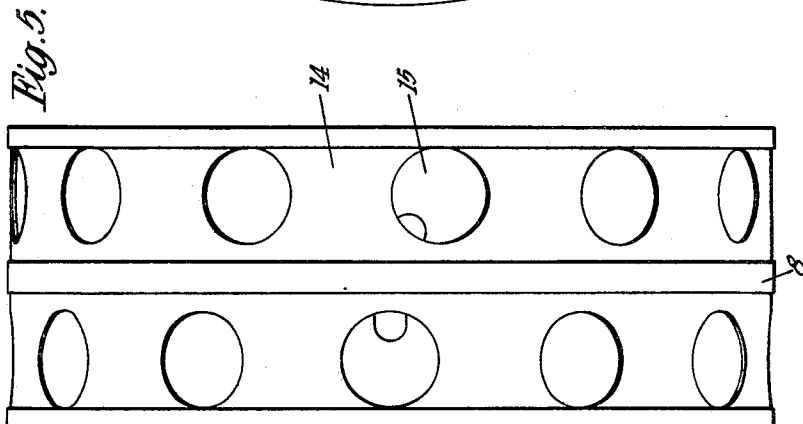
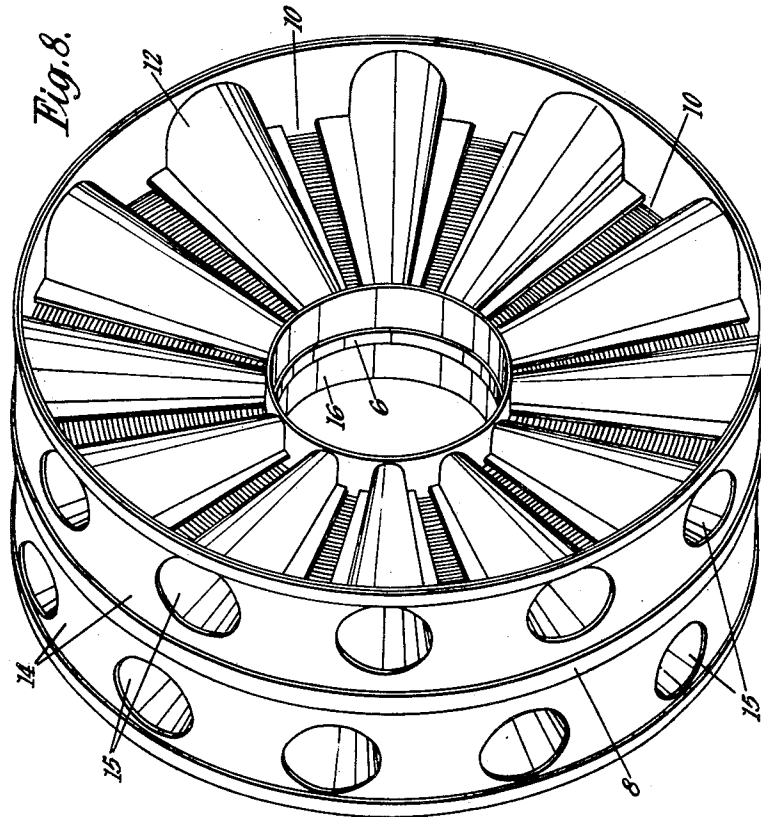

Aug. 8, 1961

W. HRYNISZAK

2,995,344

PLATE TYPE HEAT EXCHANGERS

Filed Feb. 12, 1959

5 Sheets-Sheet 5

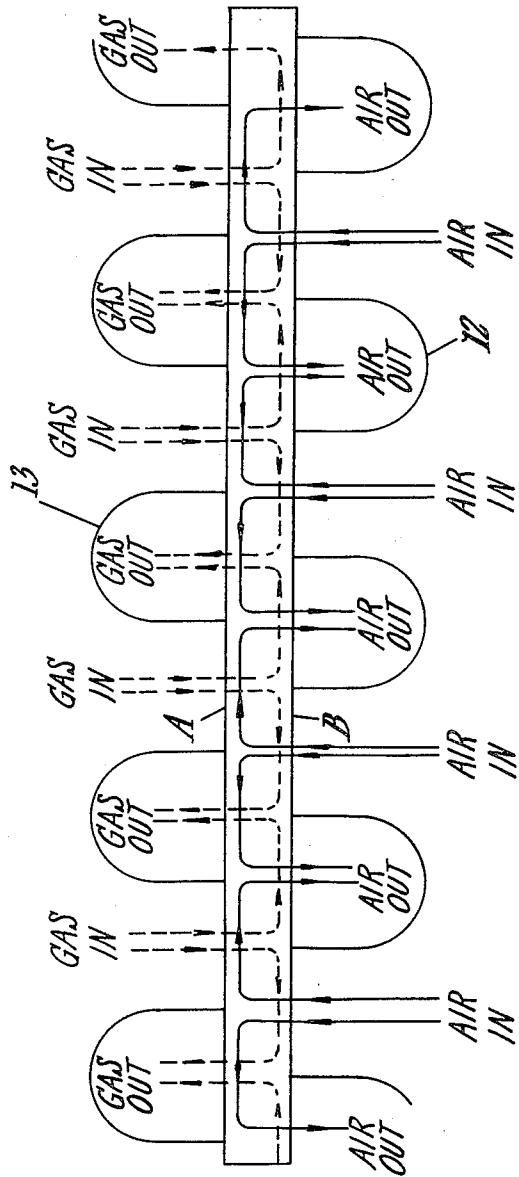

Fig. 11.

1

2,995,344

## PLATE TYPE HEAT EXCHANGERS

Waldemar Hryniszak, Newcastle-upon-Tyne, England, assignor to C. A. Parsons & Company Limited, Newcastle-upon-Tyne, England

Filed Feb. 12, 1959, Ser. No. 792,746

3 Claims. (Cl. 257-245)

This invention relates to plate type heat exchangers, that is to say heat exchangers which consist of a series of plates spaced from each other, heat exchanging fluid flowing between the plates and heat being transferred through the plates.

It is customary in such heat exchangers to stack the plates one above the other and parallel to each other, but the stacking and requisite brazing of the plates constitute a difficult operation.

In co-pending application No. 653,095 we described a plate type heat exchanger comprising a plurality of pairs of spaced sheets having side walls at the peripheral edges thereof forming flow channels of rectangular form, the spaces between the sheets being interrupted by corrugated inserts or by corrugating the sheets themselves, the length of said corrugations being such that spaces are formed between their ends and the side walls, and inlet and outlet openings being formed in said side walls said openings in one wall being in staggered relationship to the openings in the other wall, the arrangement being that hot fluid channels alternate with cold fluid channels. In one example in that specification each pair of plates was formed from continuous strips of metal and two such pairs arranged one above the other were wound round a spool the heat exchanging fluids flowing through the space between each pair of sheets in a direction parallel to the axis of the spool, so that process of assembly was considerably simplified.

The pairs of plates were separated by side walls and as the pairs of plates passed to the spool openings were milled in the side walls for the ingress and egress of the heat exchanging fluids.

The object of the present invention is to provide a plate type heat exchanger as defined above which can be assembled by winding a continuous strip on to a spool or cylinder and in which milling of ingress and egress openings can be effected when the whole of the heat exchanger has been wound on the spool and is stationary.

The invention comprises a plate heat exchanger as defined above in the form of a cylinder in which flow channels are formed between successive rings of plates. There are flow channels for hot fluid which alternate in a radial direction with other channels for a cold fluid. The peripheral edges of all of these channels are spaced by side walls with the edges of each lying on the end faces of the cylinder. There is a corrugated sheet which is positioned between the side walls in each flow channel, but also spaced therefrom. Ingress and egress openings are provided for the heat exchanging fluids which are formed in a plurality of sector shaped portions spaced over the end faces and the portions on one end face are displaced in the peripheral direction from those on the other end face. With this arrangement the ingress and egress openings for hot fluid are in one end face and the ingress and egress openings for cold fluid are in the other end face and such that hot fluid enters one end face flows axially of the cylinder is reversed in direction and leaves via outlets in the same face and cold fluid enters via the opposite face of the cylinder flows axially in the reverse direction to the hot fluid, is reversed and leaves via outlet openings in the same end face.

The invention also includes a plate type heat exchanger in accordance with the preceding paragraph in which the cylinder is built up by forming a basic element compris-

2

ing two plates spaced from each other by two side walls also spaced from each other having a corrugated strip intermediate said side walls, but spaced therefrom and two further side walls along the edges of the upper surface of the uppermost plate. There is also another corrugated strip located between but spaced from said further side walls with the side walls used being of two different widths. As illustrated, the side walls between the plates and the further side walls on the upper surface of the uppermost plate are disposed so that the narrower side wall of the said further side walls is above the wider side wall of the side walls between the plates. In addition the aforesaid basic element takes the form of a continuous strip which is coiled around a cylinder and regularly spaced radially extending portions in each face of the cylinder are cut away to a depth in an axial direction of the cylinder equal to the width of the narrower of the side walls. A plurality of grooves are formed in the end faces intermediate the cut away portions with the grooves arranged to extend to the edge of said corrugated sheets and adapted to receive outlet ducts.

The invention also consists in a plate type heat exchanger substantially as described herein.

Referring to the accompanying drawings:

FIGURE 1 shows a cross section through a number of flow channels of heat exchanger in accordance with one form of the invention;

FIGURE 1a is an enlarged section through part of FIGURE 1;

FIGURE 2 shows an end view of a heat exchanger;

FIGURE 3 shows in its upper half a section on line P—P of FIGURE 2 and in its lower half a section on line Q—Q of FIGURE 4;

FIGURE 4 is a view partly in section of the heat exchanger looking in the direction of the arrow Y in FIGURE 3;

FIGURE 5 is a side elevation;

FIGURE 6 is a developed plan view of a portion of the heat exchanger and shows inlets and outlet ducts and flow paths for heat exchange fluids;

FIGURE 7 is an enlarged section through one of the outlet ducts;

FIGURE 8 shows a pictorial or sketch view of the complete heat exchanger;

FIGURE 9 shows an enlarged portion of the basic element;

FIGURE 10 shows an enlarged view of a portion of the heat exchanger structure; and

FIGURE 11 is a schematic showing of the flow pattern of the heat exchanger.

In carrying the invention into effect in one form by way of example and referring first of all to FIGURE 1, the heat exchanger is constructed using a basic element in the form of a continuous strip which is wound on a spool or cylinder.

The basic element comprises two flat plates or sheets 1 which are spaced from one another by side walls 2 and 3. Side wall 2 is wider than side wall 3. Between plates 1 is a corrugated sheet 4 which is spaced from the side walls 2, 3. On the top surface of the uppermost plate 1 rest further side walls 2a and 3a and a further corrugated sheet 4a. The side walls 2a and 3a are arranged so that side wall 3a is immediately above side wall 2 and side wall 2a is above side wall 3.

The side walls 2, 3, plates 1 and corrugated sheets 4 may be spot welded or otherwise joined together before winding onto the spool or cylinder.

Whilst in FIGURE 1 a closing plate 5 identical with plate 1 is shown this can take the form of an outer closing ring fitted round the completed heat exchanger and thicker than the plates 1 as will be described below.

Four flow channels for heat exchanging fluid are shown

3

in FIGURE 1 by having one basic element super-imposed upon another and in the completed heat exchanger hot fluid and cold fluid flow through alternate flow channels heat transfer taking place through the plate 1.

FIGURE 1a which shows an enlarged section of FIGURE 1 is taken through the part in which the corrugated sheets 4 are located.

The thickness of the plates 1 and the side walls 2 and 3 are chosen according to the circumstances, but a typical thickness for plates 1 would be .0048" and the side walls .032". The overall thickness of the basic element is therefore 0.0736", and its width would be about 3". These figures are by way of example only and the invention is not limited thereto.

When the dimensions of the heat exchanger have been decided upon and the thickness of basic element is known, then the length of the element in continuous strip form can be calculated.

Referring to FIGURES 2-4 an inner cylindrical ring 6 having an outside diameter conforming to the desired inner diameter of the heat exchanger is mounted on a mandrel and a wedge shaped member 7 (FIGURE 4) which tapers from zero thickness to a thickness equal to the overall thickness of the basic element is welded or otherwise joined to the outer surface of the ring 6.

The basic element is then mounted on the inner ring 6 with its foremost edge abutting the end of the wedge shaped member 7 and is securely brazed or welded in position.

The basic element strip is then wound on the inner ring 6 by rotating the mandrel and winding is continued until the final required diameter is reached. Any remaining strip is then cut off and the end welded or brazed in position so that the strip is maintained in the coiled position.

An outer cylindrical ring 8 is then shrunk in position to surround the wound element and like the inner ring has a wedge shaped member 9, but in this case the member is on the inner periphery of the ring and abuts the trailing edge of the strip.

The heat exchanger is then removed from the mandrel and at regular intervals radially extending portions 10 are removed by milling. A depth of cut equal to the width of the side walls 3 is made such that alternate spaces between the plates are opened for the passage of heat exchange fluid.

In addition, grooves 11 are milled in the portion between the cut away parts 10 and these grooves 11 accommodate the outlet headers.

The plates 1 are preferably coated on each side with brazing material so that when the heat exchanger is assembled it can be brazed together by heating it to a sufficiently high temperature. Brazing foil is also inserted in the groove 11 which hold the outlet ducts.

FIGURES 2-4 show the completed heat exchanger in a form which is suitable for application in a gas turbine plant where air which is to be heated in a combustion chamber is preheated by exhaust gas from the turbine outlet.

The end face containing the air inlets and outlets is shown in FIGURE 2 whilst the end face containing the gas inlets and outlets is shown in FIGURE 4.

The milled radially extending portions 10 on the gas inlet face of the heat exchanger are displaced around the periphery from those on the air inlet face.

Outlet ducts 12 for the air are located intermediate the milled portions 10 the air passing to these outlets after it has been heated and its direction reversed by means which will be described with reference to FIGURE 6 below.

Outlet ducts 13 for the gas are located in the opposite end face as can be seen in FIGURE 4.

The outlet ducts extend for the full radial extent between inner and outer rings 6 and 8 respectively as shown

4

in FIGURE 3 and taper from the outer ring 8 towards the inner ring 6.

Around the outer and inner rings are fitted sealing bands. Outer sealing band 14 shown in FIGURE 5 contains circular apertures 15 which coincide with the tops of both air and gas outlet ducts 12 and 13 respectively. Inner sealing band 16 seals the innermost ends of the ducts 12 and 13.

The upper half of FIGURE 4 shows a section on the upper half of FIGURE 3 and the milled grooves 11 on which the ducts 13 are located are shown.

The milled grooves 11 for the ducts 12 on the opposite face are shown dotted.

The flow path for the air is illustrated in FIGURE 6. Air enters through milled radially extending inlet portion 10 and can enter spaces between alternate pairs of plates 1 from which it flows through the corrugations 4 into the space 17 between the corrugated sheet 4 and the side wall 2 which deflects it in a circumferential direction until it is again deflected by the walls 13a of duct 13 which penetrates the end face of the heat exchanger to contact the corrugated sheet. The walls 12a of ducts 12 penetrate for a similar distance on the opposite face.

On being deflected by the walls 13a the air flows in the reverse direction through the corrugated sheet to enter outlet ducts 12.

On either side of each air flow channel in a radial direction is a gas flow channel and in each gas flow channel the flow pattern is similar to that of the air.

The gas enters the side of the heat exchanger containing the gas outlet ducts 13 flows through the corrugated sheet then is deflected by a side wall 2 and then flows in reverse into the ducts 13.

Various changes and modifications are considered to be within the principle of the invention and the scope of the following claims.

I claim:

1. A plate type heat exchanger, comprising a cylindrical series of plates spaced from each other, said cylindrical series having flow channels formed between successive rings of plates, said channels defining a flow path for hot fluid alternating in a radial direction with channels for a cold fluid, side walls the edges of which lie on the end faces of the plates of a cylinder formed by the cylindrical series of plates defining the peripheral edges of said channels, a corrugated sheet positioned between said side walls in each flow channel lying in spaced relation to said walls, ducts radially spaced over both end faces of the cylinder having ingress and egress openings for the heat exchanging fluids, said end faces defining the ingress and egress openings for fluid flow in one end face and the ingress and egress openings for fluid flow in the other end face whereby hot fluid enters one end face flows axially of the cylinder is reversed in direction and leaves outlets in the same face and cold fluid enters the opposite end face of the cylinder and flows axially in the reverse direction to the hot fluid, is reversed and leaves outlet openings in the same end face.

2. A plate type heat exchanger as claimed in claim 1, wherein grooves in the side walls extend to the edge of said corrugated sheet and are adapted to receive said outlet ducts.

3. A plate type heat exchanger as claimed in claim 2, wherein said outlet ducts are arranged in staggered relation on said side walls and the egress openings thereof are peripherally positioned relative to said cylinder.

References Cited in the file of this patent

UNITED STATES PATENTS

Re. 19,140	Frankl	Apr. 17, 1934
2,368,732	Wallgren	Feb. 6, 1945
2,874,940	Ahlen	Feb. 24, 1959