



INTERNATIONAL APPLICATION PUBLISHED UNDER THE PATENT COOPERATION TREATY (PCT)

<p>(51) International Patent Classification ⁶ : A61B 17/39, 5/0424, A61N 1/08</p>	<p>A1</p>	<p>(11) International Publication Number: WO 99/11187 (43) International Publication Date: 11 March 1999 (11.03.99)</p>
<p>(21) International Application Number: PCT/US97/24106 (22) International Filing Date: 30 December 1997 (30.12.97) (30) Priority Data: 08/924,037 29 August 1997 (29.08.97) US (71) Applicant: MINNESOTA MINING AND MANUFACTURING COMPANY [US/US]; 3M Center, P.O. Box 33427, Saint Paul, MN 55133-3427 (US). (72) Inventor: NETHERLY, Samuel, G.; P.O. Box 33427, Saint Paul, MN 55133-3427 (US). (74) Agents: HORNICKEL, John, H. et al.; Minnesota Mining and Manufacturing Company, Office of Intellectual Property Counsel, P.O. Box 33427, Saint Paul, MN 55133-3427 (US).</p>	<p>(81) Designated States: AL, AM, AT, AU, AZ, BA, BB, BG, BR, BY, CA, CH, CN, CU, CZ, DE, DK, EE, ES, FI, GB, GE, GH, GM, GW, HU, ID, IL, IS, JP, KE, KG, KP, KR, KZ, LC, LK, LR, LS, LT, LU, LV, MD, MG, MK, MN, MW, MX, NO, NZ, PL, PT, RO, RU, SD, SE, SG, SI, SK, SL, TJ, TM, TR, TT, UA, UG, UZ, VN, YU, ZW, ARIPO patent (GH, GM, KE, LS, MW, SD, SZ, UG, ZW), Eurasian patent (AM, AZ, BY, KG, KZ, MD, RU, TJ, TM), European patent (AT, BE, CH, DE, DK, ES, FI, FR, GB, GR, IE, IT, LU, MC, NL, PT, SE), OAPI patent (BF, BJ, CF, CG, CI, CM, GA, GN, ML, MR, NE, SN, TD, TG).</p> <p>Published <i>With international search report.</i></p>	

(54) Title: METHOD AND APPARATUS FOR DETECTING LOSS OF CONTACT OF BIOMEDICAL ELECTRODES WITH PATIENT SKIN

(57) Abstract

A method of monitoring the contact of a biomedical electrode to skin of a patient is disclosed, where at least two different frequencies are employed to periodically monitor total contact impedance of the electrode. The ratio of the change of the total contact impedances over time can then be monitored to indicate the amount of lift of the biomedical electrode from human skin to which it is supposed to be adhered. Lift of any portion of the electrode from contact with skin of a patient can be monitored more easily than using conventional Contact Quality Monitoring circuitry and "split plate patient plates".

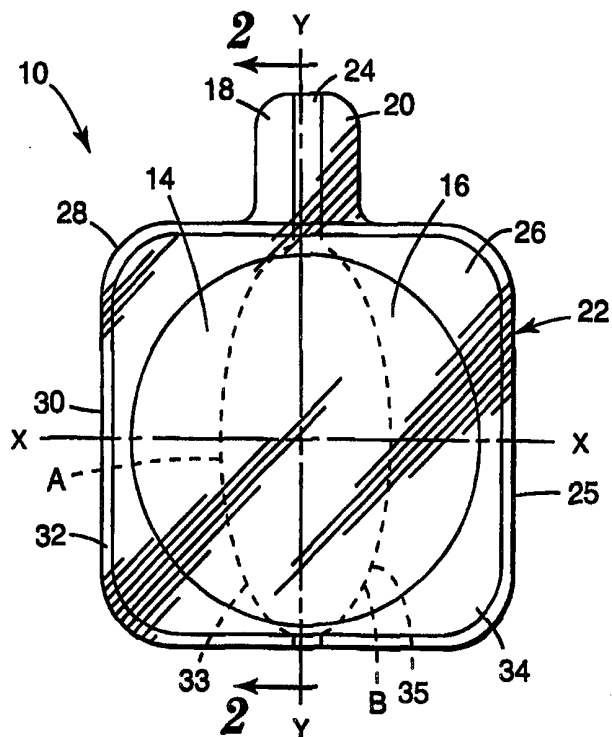

FOR THE PURPOSES OF INFORMATION ONLY

Codes used to identify States party to the PCT on the front pages of pamphlets publishing international applications under the PCT.

AL	Albania	ES	Spain	LS	Lesotho	SI	Slovenia
AM	Armenia	FI	Finland	LT	Lithuania	SK	Slovakia
AT	Austria	FR	France	LU	Luxembourg	SN	Senegal
AU	Australia	GA	Gabon	LV	Latvia	SZ	Swaziland
AZ	Azerbaijan	GB	United Kingdom	MC	Monaco	TD	Chad
BA	Bosnia and Herzegovina	GE	Georgia	MD	Republic of Moldova	TG	Togo
BB	Barbados	GH	Ghana	MG	Madagascar	TJ	Tajikistan
BE	Belgium	GN	Guinea	MK	The former Yugoslav Republic of Macedonia	TM	Turkmenistan
BF	Burkina Faso	GR	Greece	ML	Mali	TR	Turkey
BG	Bulgaria	HU	Hungary	MN	Mongolia	TT	Trinidad and Tobago
BJ	Benin	IE	Ireland	MR	Mauritania	UA	Ukraine
BR	Brazil	IL	Israel	MW	Malawi	UG	Uganda
BY	Belarus	IS	Iceland	MX	Mexico	US	United States of America
CA	Canada	IT	Italy	NE	Niger	UZ	Uzbekistan
CF	Central African Republic	JP	Japan	NL	Netherlands	VN	Viet Nam
CG	Congo	KE	Kenya	NO	Norway	YU	Yugoslavia
CH	Switzerland	KG	Kyrgyzstan	NZ	New Zealand	ZW	Zimbabwe
CI	Côte d'Ivoire	KP	Democratic People's Republic of Korea	PL	Poland		
CM	Cameroon	KR	Republic of Korea	PT	Portugal		
CN	China	KZ	Kazakistan	RO	Romania		
CU	Cuba	LC	Saint Lucia	RU	Russian Federation		
CZ	Czech Republic	LI	Liechtenstein	SD	Sudan		
DE	Germany	LK	Sri Lanka	SE	Sweden		
DK	Denmark	LR	Liberia	SG	Singapore		
EE	Estonia						

Method and Apparatus for Detecting Loss of Contact of Biomedical Electrodes With Patient Skin

5 Field of Invention

This invention concerns a method and apparatus for detecting loss of contact with patient skin of biomedical electrodes, particularly dispersive return electrodes or “patient plates” having lossy dielectric properties, during delivery of electrical current to a patient, particularly during electrosurgery. More particularly,
10 the invention concerns a method of determining whether an electrosurgical patient plate has accidentally lifted in any location from a patient’s skin.

Background of Invention

Biomedical electrodes are used in a variety of applications and are
15 configured to operate according to the size, type, and direction of current flowing into or out of a body of a patient.

Dispersive electrodes are used in electrosurgery. In modern surgical practice, there are many times when electrosurgery is more preferable than the use of the traditional scalpel. In electrosurgery, cutting is performed by an intense electrical
20 current passing through a cutting electrode. The surgeon directs this current to exactly where cutting is required by wielding the cutting electrode, which because of its cylindrical shape and the way it is held in the hand is commonly called an “electrosurgical pencil”. By activating controls which change the characteristics of the electrical current being sent to the pencil by an electrosurgical generator, the
25 surgeon can use the pencil either to cut or to coagulate areas of bleeding. This makes electrosurgery particularly convenient when surgery requiring extra control of blood loss is being performed. Because of concerns to minimize the transmissions of blood-borne illnesses between health care patients and health care providers, in both directions, electrosurgery is becoming increasingly important.

30 In electrosurgery, as in all situations where electrical current is flowing, a complete circuit must be provided to and from the current source. In this

case, the current that enters the body at the pencil must leave it in another place and return to the generator. It will readily be appreciated that when current enough to deliberately cut is brought to the body of a patient in one place, great care must be taken that unintentional damage is not also done to the patient at the location where
5 that current is leaving the body. The task of collecting the return current safely is performed by a dispersive electrode.

A dispersive electrode performs this task by providing a large surface area through which the current can pass; the same current which was at cutting intensity when focused at the small surface area at the tip of the pencil is relatively
10 harmless, with the goal of being painless to the patient, when spread out over the large surface area of the dispersive electrode.

Unfortunately, any geometry of the large surface area has an edge and perhaps distinct corners or junctions where "edge effects", caused by increased current density at those locations, can have a maximum temperature rise during usage
15 by the patient making such dispersive electrode or cardiac stimulating electrode most uncomfortable to the patient.

The same difficulties concerning edge effect also are present in cardiac stimulating electrodes, such as those used for defibrillation, external pacing, or cardioversion. For a patient already in some discomfort or ill health, pain sensed
20 by the very medical device intended to treat the patient is disconcerting at best.

Safety systems for the electrosurgical patient plates use "Contact Quality Monitor" ("CQM") circuits. All CQM systems currently in use are based on a single design, involving the use of a split patient plate. The reason that the plate must be split is to create two separate conductors that are not electrically
25 joined, unless the electrode is placed on the skin of a patient. If it is indeed properly placed, then a small current can be passed by the generator down one wire of the cable connecting the generator to one of the conductors on the split plate. From there, the current then passes into the flesh of the patient, crosses over to the other conductor of the split plate, and then back through the other wire of the
30 connecting cable to the generator. By analyzing this current, the generator is able

to measure an impedance for the combined circuit of the cable, both halves of the split plate, and the patient.

This impedance must be within a certain pre-determined range which assures that the plate has been placed on the patient and that it is in full or
5 nearly full contact with the skin of the patient.

One other point should be made about these CQM systems, and the current that is used by them to determine when the plate is in good contact with the patient: The CQM current should not be confused with the surgical current, which does all the cutting and coagulating. The CQM current is a lower frequency
10 (typically about 39-350 KHz) than the surgical current frequency (typically about 500-1000 KHz), and is hundreds of times smaller in both voltage and amperage than the surgical current (about 1 mV and 1 mA vs. about 500 V and 2 A, respectively).

It is also important to note that the CQM system is only active when
15 the surgical current is not flowing, since the surgical current is so powerful that it would burn out the CQM circuit if the CQM circuit were active while the surgical current was flowing.

The CQM system, first introduced in 1984, has become the industrial safety standard for electrosurgery. Further disclosure of the CQM
20 system is found in U.S. Pat. Nos. 4,200,104 (Harris); 4,231,372 (Newton); 4,416,277 (Newton et al.) ; 4,416,276 (Newton et al.); and 4,848,335 (Manes).

In addition to the CQM system, additional systems have been developed. One of them is the "NESSY" system sold by Erbe, Inc. of Tübingen, Germany. The system has two separate circuits, with the first circuit being the
25 standard CQM type described above. The second circuit, however, is unique to the Erbe generator and actually measures the surgical current that is flowing through both halves of the split plate. The amperage flowing in the two halves of the plate is compared, and if there is too great a difference between the current levels the generator will alarm and shut down.

30 Another attempt to provide protection for an electrosurgery patient is disclosed in U.S. Pat. No. 5,080,099 (Way et al.). In these patents are disclosed

a triple plate electrode in order to provide a measure of “peel back” of the patient plate from the patient. But these electrodes disclosed in the Way et al. patent were quite complex to manufacture and use.

5 Summary of Invention

The present invention determines whether an electrosurgical patient plate has accidentally lifted from a patient’s skin. This method is an unexpected and significant improvement over the sensitivity and accuracy of any Contact Quality Monitoring or “NESSY” system used in an electrosurgical generator today.

10 The present invention does not necessarily require the use of a split patient plate.

However, the present invention does require the use of a patient plate with a lossy dielectric region at its periphery and is not applicable to standard resistive or capacitive plates. Nonlimiting examples of a patient plate with a lossy dielectric region at its periphery include those biomedical electrodes disclosed in
15 PCT Publication WO 97/37719.

One aspect of the present invention is the use of a lossy dielectric plate in conjunction with electronic circuitry that is uncomplicated to initiate and employ. The method and apparatus of the present invention utilizes the Netherly patient plate, which is unique in that it does not pass current through its surface in
20 the same way at all points.

At the corners and the very outer border of the lossy dielectric surface, the current emerging from the patient (or introduced to a patient in the case of a stimulating or pacing electrode) is forced to pass through the lossy dielectric layer in a “more capacitive than resistive” way.

25 Another aspect of the invention is a method of determining small amounts of lift of a biomedical electrode from a patient’s skin, provided that biomedical electrode has at least part of its conductor area coated with a lossy dielectric material. The method of determining lift comprises measuring the contact impedance of the biomedical electrode on the patient at two substantially
30 different frequencies upon initial application, and then comparing later pairs of readings with the first pair of impedances measured, wherein a greater change of

impedance at the lower frequency point as compared to the upper frequency point indicates that a part of the biomedical electrode coated with lossy dielectric has become detached from the patient's skin.

Another aspect of the present invention is to use the following
 5 Equation I to determine the degree of lift of the biomedical electrode:

$$\text{Degree of Lift} = (Z_{f1t0} - Z_{f1t1}) / (Z_{f2t0} - Z_{f2t1}) \quad \text{I}$$

where Z denotes the total contact impedance of the biomedical electrode, f1 denotes the first impedance measurement frequency, f2 denotes the second
 10 impedance measurement frequency, t0 denotes the first (or initial) impedance measurement time, and t1 denotes the impedance measurement at some later time. This degree of lift may be represented by digital or analog means on a display on the electrosurgical generator to indicate the relative amount of the biomedical electrode that has lifted since the initial application, and in addition, if this degree
 15 of lift exceeds a certain set value, an alarm can be made to sound to audibly alert the user to the degree of lift. In addition to a simple auditory alarm, an increase of the degree of lift beyond a threshold value can also trigger an alarm condition which will disable the generator until the lift of the biomedical electrode from the patient's skin has been corrected.

20 When such materials are used in the Netherly plate disclosed in PCT Publication WO 97/37719, one can use Equation I with at least two different frequencies to determine whether changes in impedances occur at different times of measurement: initially and at least one time later.

Preferably, the method and apparatus of the present invention can be
 25 used in conjunction with another method that determines the total phase angle (Θ_{Total}) of current flow, which is equal to the sum of the phase angle of the current flow passing through the lossy dielectric area and the phase angle of the current passing through the bare metal area of the electrode surface near the center of the plate, as seen in Equation II.

30

$$\Theta_{\text{Total}} = [\Theta_{\text{Lossy Dielectric}} * (\text{Area}_{\text{Lossy Dielectric}} / \text{Area}_{\text{Total}})] + [\Theta_{\text{Bare Metal}} * (\text{Area}_{\text{Bare Metal}} / \text{Area}_{\text{Total}})] \quad \text{II}$$

Thus, if the relative area of the bare metal and lossy dielectric
 5 contacting the patient changed, there would be a net change of the phase angle of
 the total current flow.

Using the Netherly Patient Plate with coverage of lossy dielectric
 material from portions of the perimeter inward, and preferably at the corners and
 edges of the electrical conductor, there is no way that the plate can be peeled up
 10 from any direction while keeping the ratio of bare metal area to lossy dielectric
 area the same. The ratio of lossy dielectric area to bare metal area is significant to
 both Equations I and II, as seen above.

In relation to Equation I, as the ratio changes, such as lifting off of
 an edge of a biomedical electrode, the total contact impedance changes. The
 15 present invention has found that the change in total contact impedance differs at
 different frequencies.

With the ability to establish initial, customized values of total
 contact impedance at two different frequencies and then measure such total contact
 impedances at those two different frequencies at a later time, then one can monitor
 20 if and when the edge or corner of a biomedical electrode begins to lift off the skin
 of a patient, and preferably how much lift has occurred.

The ratio of change of total contact impedance values at two
 different frequencies, over time, is independent of any other parameter or property
 of the biomedical electrode. Further biomedical instrumentation can be calibrated
 25 to measure any determined ratio of change of total contact impedances at two
 different frequencies before an alarm is sounded.

In relation to Equation II, the measure of change of phase angle over
 change in time is independent of any other parameter or property of the biomedical
 electrode, because electronic circuitry in the biomedical instrumentation can
 30 measure $\delta\Theta / \delta t$ without regard to any other function, property, or parameter of the

patient plate. Further the biomedical instrumentation can be calibrated to measure any amount of $\delta\Theta/\delta t$ before an alarm is sounded.

Therefore, by monitoring the ratio of change of the total contact impedances at two different frequencies through any biomedical electrode over
5 time, one can determine whether contact between the biomedical electrode and skin of a patient has changed. While any change in direct contact is not as critical for monitoring biomedical electrodes where any contact could be enough to receive faint electrical signals from the patient, any change in direct contact is critical for any biomedical electrode that requires the delivery of electrical current to a patient
10 or receives from the patient electrical current delivered to the patient in another location.

Another aspect of the present invention is the use of any geometric configuration of electrical conductor on a biomedical electrode, so long as a portion of the electrical conductor is covered with a lossy dielectric material. Thus,
15 using Equation I above, one need not configure a biomedical electrode to have two or more electrical conductors nor need one use either a CQM or NESSY system that relies on differences in current flow between two or more electrical conductors on the surface of the biomedical electrode. The method of the present invention pertains to a split conductor patient plate or a solid conductor patient plate equally
20 well, so manufacturing and performance economies of scale can be achieved regardless of the electrical conductor geometry, but a solid conductor patient plate is easier to make and use.

A feature of the present invention is that, if one were to pass a stream of current through a lossy dielectric Netherly patient plate and monitor the
25 total contact impedances at two different frequencies, the rate of change of the total contact impedances over time should vary relative to each other's value if any portion of the periphery of the plate were lifted. In all cases presently contemplated, a decrease in total contact impedances at two different frequencies should be observed because the area being lifted from any edge would always have
30 more lossy dielectric coating than bare metal lifted.

The two different frequencies can be selected to accommodate a discernible divergence in total contact impedances when measured after initial values are determined. One frequency can range from about 2 MHz to about 100 KHz and preferably from about 1 MHz to about 300 KHz. The second frequency
5 can range from about 100 KHz to about 1 KHz and preferably from about 5 KHz to about 50 KHz. While at least two different frequencies are required, the present invention can use more than two frequencies, particularly if more than type of alarm condition is desired. Also, selection of the frequencies for the method of the present invention should accommodate the ability to quantify the amount of lift of
10 an electrode from a patient's skin. Such quantification can take the form of a series of audible alarms increasing in urgency with increasing edge lift, a digital or analog display of numerical quantity or graphic information, or the like used to provide to health care professionals clear indications of an undesirable condition for the patient.

15 An advantage of the present invention is that a clearly superior method is provided to measure biomedical electrode lift from skin of a patient, because the most likely source for lift to start would be at the corners of the electrode, and this is precisely where the lossy dielectric coating on an electrical conductor of a Netherly patient plate is located.

20 Moreover, another advantage of the present invention is the ability of monitoring lift of a solid, single conductor biomedical electrode, and that this lift could be detected regardless of which way the electrode begins to lift.

Yet another advantage of the present invention is the ability to combine the method and apparatus of the present invention with the other method
25 of monitoring edge lift as disclosed above.

Thus, the invention can be expressed in a variety of ways:

The invention includes a method of detecting loss of contact between a biomedical electrode and skin of a patient, comprising the steps of
30 (a) detecting total contact impedance of the electrode at two different frequencies to establish two initial contact impedances; (b) detecting the total contact impedances of the electrode at the same frequencies as in step (a) at at least one

later time to establish two differences in total contact impedance, one difference for each frequency; and (c) sounding an alarm when the ratio of the two differences exceeds a predetermined amount.

The invention also includes a method of quantifying lift off of a biomedical electrode from skin of a patient, by the use of the equation:

$$\text{Degree of Lift} = (Z_{f1t0} - Z_{f1t1}) / (Z_{f2t0} - Z_{f2t1})$$

where Z denotes a total contact impedance of the biomedical electrode, f1 denotes a first impedance measurement frequency, f2 denotes a second impedance measurement frequency, t0 denotes a first (or initial) impedance measurement time, and t1 denotes a impedance measurement at some later time, comprising the steps of (a) measuring two initial total contact impedances using two different frequencies, (b) measuring two later time total contact impedances using the same two frequencies as in step (a) and using the equation to obtain a ratio of change of the two total contact impedances; and (c) sounding an alarm when the ratio of change of the two total contact impedances exceeds a certain set value.

The invention also includes a method of determining the amount of skin contact between a biomedical electrode and skin of a patient, comprising the steps of (a) measuring the ratio of the change of two total contact impedances, measured at different frequencies, over time for an energized biomedical electrode; and (b) sounding an alarm when the ratio of the change of the difference in total contact impedances over time exceeds a predetermined amount.

The invention further includes an apparatus for detecting loss of contact between a biomedical electrode and skin of a patient, comprising (a) a biomedical electrode having an electrical conductor having at least a portion thereof having lossy dielectric properties; and (b) means for detecting when a change in the ratio of the change of two total contact impedances measured at two different frequencies over time exceeds a predetermined amount.

Further features and advantages of the invention become apparent using the following drawings to describe the embodiments.

Brief Description of the Drawing

The reference numerals refer to like parts in the several views, wherein:

Fig. 1 is bottom perspective view according to one presently preferred embodiment of the dispersive electrode of the present invention;

Fig. 2 is a cross-section view which is taken along section lines 2-2 in Fig. 1;

Fig. 3 is a graph showing total contact impedance vs. area of electrode surface for a conventional biomedical electrode using three different frequencies, demonstrating little change for total contact impedances of the various frequencies as the amount of electrode surface area was reduced;

Fig. 4 is a graph showing total contact impedance vs. area of electrode surface for a lossy dielectric biomedical electrode, both actual and theoretical data, using three different frequencies, demonstrating the differing rate of decrease in the total contact impedances at the various frequencies, as the amount of electrode surface area was reduced.

Embodiments of the Invention

Fig. 1 shows a bottom perspective view of the dispersive biomedical electrode "patient plate" 10. The upper surface of the electrode 10, which is on the far side in this bottom view, can be a flexible and conformable electrically non-conductive backing 12. At least one conductor plate is needed for electrical contact with the body of a patient. In this embodiment, two conductor plates 14 and 16 are present along a longitudinal axis Y-Y matching Section line 2-2, adjacent to, and can be adhered to, the electrically non-conductive backing 12. Two separate conductor plates can be employed because of their usefulness with contact quality monitoring ("CQM") circuitry because the impedance between the conductor plates 14 and 16 is measured by the above mentioned CQM circuits. However, one can also preferably use a single conductor plate that combines conductor plates 14 and 16, the more traditional style of dispersive electrode before CQM circuitry became available.

Each of the two conductor plates 14 and 16 has an extended tab 18 and 20, respectively, extending away from the body contact portion 22 of the electrode 10 for attachment of a cable assembly which connects the electrode 10 to an electrosurgical generator (not shown). When only one conductor plate is present on backing 12, there is only one extended tab. In order to provide more support for the conductor plates 14 and 16, and especially for their respective tabs 18 and 20, a non-conductive support layer 24 can be laminated to the conductor plates. More preferably, the support layer is not needed if manufacturing techniques can be refined.

The region adjacent the exterior edge 25 of the body contact portion 22 of the electrode 10 is covered with a layer 26 of a lossy dielectric material. In the embodiment of Figure 1, the width of the layer 26 of a lossy dielectric material is widest at the corners 28, and narrowest along the edge 30 midway between the corners. As presently understood, this arrangement of the layer 26 serves best to reduce edge effect at the corners 28 of the dispersive electrode. Further explanation of the use of a lossy dielectric material can be found in PCT Publication WO 97/37719.

Preferably, the entire body contact portion 22 of electrode 10 is covered with a field 32 of hydrophilic, ionically conductive, pressure sensitive adhesive for simplicity of manufacturing. Many compositions suitable for use for the field 32 of conductive adhesive are transparent, or at least translucent, and have been depicted that way in Fig. 1 for convenience in providing an explanatory drawing. The field 32 of adhesive serves the purpose of adhering the electrode 10 to the body of the patient. When the field 32 is adhesive that is ionically conductive, as it should be for those portions of field 32 contacting plates 14 and 16, the field also has the purpose of transferring the electrosurgical current between the body of the patient and the electrode for electrosurgical currents and between the electrode and the body for total contact impedance analysis according to the present invention.

Each of conductor plates 14 and 16 has an interior edge, 33 and 35 respectively, along the longitudinal axis Y-Y as seen in Figure 1. Each of edges 33

and 35, or one of them, can be parallel, curvilinear or otherwise non-parallel to the opposing edge in a manner which creates a concave-inward indent relative to the longitudinal axis Y-Y. Preferably, both edges 33 and 35 have curvilinear geometries relative to the longitudinal axis, resulting in a double concave-inward indent symmetrical about the longitudinal axis. More preferably, the double concave-inward indent is also symmetrical about an axis orthogonal to the longitudinal axis, where the second axis is a latitudinal axis X-X substantially equidistant from edges of the body contact portion 22 orthogonal to the longitudinal axis. Most preferably, as seen in Fig. 1, at the point where longitudinal axis Y-Y and latitudinal axis X-X cross orthogonally, the non-conductive gap between edges 33 and 35 is maximal.

It will be seen that at point A which is away from the outside edge of the body contact portion 22 of biomedical electrode 10, the minimum distance separating the conductive plates 14 and 16 is substantially greater than the minimum distance separating the conductive plates at a point B nearer the outside edge of the body contact portion.

Fig. 2 shows a cross-section view of the electrode shown in Fig. 1, taken along section lines 2-2. In this view, a release liner 34 is shown adhered to the field 32 of hydrophilic adhesive. In those portions of electrode 10 where adhesive field 32 contacts one or more conductive plates 14 and 16, the adhesive field 32 is also ionically conductive. This release liner 34 protects the adhesive during shipping and handling and is removed just prior to use. In this view a layer of adhesive 36 is seen adhering the support layer 24 to conductor plate 14 and its extended tab 18. Another layer of adhesive 38 is provided for adhering the electrically non-conductive backing 12 to the other side of the support layer 24.

Electrically non-conductive backing

Electrically non-conductive backing 12 can be electrically insulative, and preferably is very conformable to the various contours of the mammalian body. Many materials can be used for this purpose, as will be apparent to those skilled in the art. In one presently preferred embodiment, a closed-cell

foam is considered particularly suitable. One such material is commercially available as Volara brand foam from Voltek, Inc. of Massachusetts. Another is commercially available as a laminate of nonwoven polypropylene and low density polyethylene backing from Milliken of Spartanburg, South Carolina. The
5 electrically non-conductive backing can have a thickness ranging from about 0.75 mm (0.03 inch) to about 1.5 mm (0.06 inch), and preferably 1.0 mm (0.04 inch).

Conductor plates and support layer

The conductor plates 14 and 16 are conveniently made from metal,
10 preferably in the form of a foil, a metal-containing or graphite-containing coated ink or paint, or a vapor coated metal, and most preferably, aluminum foil. If a support layer 24 is not being used, a thickness of about 0.08 mm (0.0003 inch) is considered preferred. If a support layer 24 is being used, the metal foil or vapor coated metal can be thinner because of the support provided by the support layer.
15 A suitable support layer 24 can be made from polyethylene terephthalate (PET) film, conveniently approximately 0.05 mm (0.002 inch) thick. This allows the aluminum layer to range in thickness between about 0.0075 mm (0.0003 inch) to about 0.025 mm (0.001 inch) and preferably 0.012 mm (0.0005 inch) or allows vapor coated metal to have a minimum thickness of about 1000 Angstroms. An
20 example of vapor coated metal on a substrate is found in PCT Publication No. WO 94/26950.

Hydrophilic adhesive

Each of the hydrophilic adhesives useful in the present invention
25 should be biocompatible with mammalian skin and can be formulated in both ionically conductive and non-conductive embodiments. The ionically conductive adhesives are useful in contact with both mammalian skin and conductor plates 14 and 16. The non-conductive adhesives can be used beyond the perimeter of the conductor plates 14 and 16.

30 Preferably, if expense of a single field 32 of hydrophilic, ionically conductive, biocompatible, pressure sensitive adhesive is not greater than the

expense during manufacturing of applying two different types of adhesive to comprise field 32, then a single field is used even if ionic conductivity is not required to be present in the perimeter section of field 32 not contacting conductor plates 14 and 16.

5 Nonlimiting examples of hydrophilic adhesives useful in connection with the present invention include those compositions disclosed in U.S. Patent Nos. 4,524,087 (Engel); 4,539,996 (Engel); 4,848,353 (Engel) and 5,133,356 (Bryan et al), ; 5,225,473 (Duan); 5,276,079 (Duan et al); 5,338,490 (Dietz et al); 5,362,420 (Itoh et al); 5,385,679 (Uy et al); PCT Publication Nos. WO 95/20634; 10 WO 94/12585; WO 97/24376; WO 97/24149; and WO 97/24378. Further nonlimiting examples of hydrophilic adhesives that do not have ionically conductive properties but would be useful for the perimeter section of field 32 include U.S.Pat. Nos. 4,871,812 and 5,407,717 (both Lucast et al.); 4,981,903 and Re 34,958 (both Garbe et al.); 5,009,224 (Cole); 5,232,838 (Nelson et al.); and 15 5,270,358 (Asmus); PCT Publication WO 95/27016; and adhesives commercially available from the Medical Specialties Department of 3M Health Care, 3M Company, St. Paul.

Release liner

20 Release liner 34 can be any construction suitable for protecting the conductive adhesive 32 during shipping and handling while still releasing easily from the conductive adhesive at the time of use. One suitable liner is a 0.05 mm (0.002 inch) thick sheet of biaxially oriented polypropylene liner, commercially available as Daubert 164Z from Daubert Co. of Dixon, IL.

25

Adhesive layers

In some presently preferred embodiments, adhesive layers 36 and 38 may be used for holding other components of the electrode 10 together. Nonlimiting examples suitable adhesives 36 and 38 include acrylate ester 30 adhesives, and more particularly acrylate ester copolymer adhesives. Such adhesives are generally described in U.S. Patent Nos. 2,973,826; Re 24,906; Re

33,353; 3,389,827; 4,112,213; 4,310,509; 4,323,557; 4,732,808; 4,917,928; 4,917,929; and European Patent Publication 0 051 935.

Lossy dielectric layer

5 The layer 26 of lossy dielectric material has the performance parameters identified above in association with the ultimate performance of electrode 10 to minimize the maximum rise in temperature of tissue of a patient during electrosurgical procedures.

10 The lossy dielectric layer 26 can occupy an area of the body contact portion 22 ranging from about 5% to about 70% and preferably from about 40% to about 60%.

15 The lossy dielectric layer 26 can be made from a material and be applied in a non-uniform thickness to result in an electrical impedance gradient from the center of the body contact portion 22 to the exterior edge 25 ranging from about 30% to about 90% of the maximum impedance at exterior edge 25, and preferably from about 50% to about 70% of the maximum impedance at exterior edge of body contact portion 22.

20 The layer 26 can have a maximum impedance/area at the exterior edge 25 of the body contact portion 22 of the electrode 10 ranging from about $0.387 \Omega / 129 \text{ cm}^2$ to about $20 \Omega / 129 \text{ cm}^2$ and preferably ranging from about $1 \Omega / 129 \text{ cm}^2$ to about $8 \Omega / 129 \text{ cm}^2$, as determined by use of a Schlumberger 1260 spectrum impedance analyzer, operating at a frequency of 500 KHz and a constant voltage of 60 mV (RMS), and subjected to a nulling file to subtract out the effects of leadwires, connecting clips, and test fixture. A dispersive electrode of 25 approximately 129 cm^2 (20 in^2) is the approximate size of most commercially available dispersive electrodes.

30 The layer 26 can have a resistance component per unit area (R/area) of the complex impedance Z of from about $0.4 \Omega / 129 \text{ cm}^2$ to about $5 \Omega / 129 \text{ cm}^2$ at exterior edge 25 on the dispersive electrode 10. Preferably, the layer 26 can have a resistance component per unit area ranging from about $0.5 \Omega / 129 \text{ cm}^2$ to

about $1.4 \Omega / 129 \text{ cm}^2$. These values were determined as done for the maximum impedance per unit area.

The layer 26 can have a reactance component per unit area (X / area) of the complex impedance of from about $-0.5 \Omega / 129 \text{ cm}^2$ to about $-16 \Omega / 129 \text{ cm}^2$ at exterior edge 25 on the dispersive electrode 10. Preferably, the layer 26 can have a reactance component per unit area ranging from about $-2 \Omega / 129 \text{ cm}^2$ to about $-10 \Omega / 129 \text{ cm}^2$, using the same testing method as above for resistance per unit area and impedance per unit area.

The layer 26 can have a $\tan \delta$ ranging from about 0.14 to about 1.7 at exterior edge 25 on the electrode 10, when measured at 500 KHz and a signal amplitude of 60 mV (RMS). Desirably, the $\tan \delta$ can range from about 0.2 to about 1.0 at exterior edge 25 on the electrode 10, when measured at 500 Hz and a signal amplitude of 60 mV (RMS). Preferably, the $\tan \delta$ ranging from about 0.2 to about 0.7 at exterior edge 25 on the electrode 10, when measured at 500 Hz and a signal amplitude of 60 mV (RMS).

Layer 26 can be made from any lossy dielectric material that can be applied to body contact portion 22 and provide the performance parameters identified above for layer 26.

Layer 26 can be formed from an ink or paint on body contact portion 22 according to electrode manufacturing techniques known to those skilled in the art. It has been found particularly convenient to provide this material in the form of a paint, which can then be screen printed or sprayed in an appropriately shaped pattern onto the electrode 10 at the proper time during its fabrication. Oil-based enamels, commercially available as Cat. nos. 7776, 7790, 7730, 7727, and 7715 from Rust-oleum Corp. of Vernon Hills, IL are considered particularly suitable. Inks such as Summit UVII 300, UVII 800, and UVII 801 white inks, from Summit, Inc. of North Kansas City, MO and Werneke Ultrafuse UFR Green, # UFGUB0008 from Werneke, Inc. of Plymouth, MN can also be used. Additional information on the use of a lossy dielectric layer to reduce the heating caused by edge effect can be found in PCT Publication WO 97/37719.

Method of Making Electrodes

Electrode 10 can be made using conventional tab/pad style electrodes as described in U.S. Pat. Nos. 4,352,359 (Larimore); 4,524,087 (Engel); 4,539,996 (Engel); 4,554,924 (Engel); 4,848,348 (Carim); 4,848,353 (Engel); 5,012,810 (Strand et al.); 5,133,356 (Bryan et al.); 5,215,087 (Anderson et al.); and 5,296,079 (Duan et al). Generally, multiple layered electrode 10 can be assembled from rolls of starting materials for insulative electrically non-conductive backing 12, upon which is applied conductor plates 14 and 16, upon which is coated paints or inks to form lossy dielectric layer 26, upon which is coated or cured field 32 of hydrophilic, ionically conductive pressure sensitive adhesive. Alternatively, a sheet of lossy dielectric material of a desired geometrical shape can be laminated onto conductor plates 14 and 16.

Automated machinery can be employed to make electrode 10. One skilled in the art of making electrodes can select from a variety of machinery manufacturers and manufacturing techniques to minimize manufacturing expense and waste. Some types of machinery are disclosed in U.S. Pat. Nos. 4,715,382 (Strand); 5,133,356 (Bryan et al.); PCT Publication WO 96/15715; and U.S. Pat. No. 5,352,315 (Carrier et al.).

Method of Monitoring Total Contact Impedances

Any electronic method suitable for "real time" monitoring of total contact impedances at two different frequencies in an electrical circuit is acceptable for use in the present invention. Because of the constant advances in electronics, no one manner of monitoring of total contact impedances can be identified as clearly superior to another. However, several known methods can be outlined as presently suitable for use in the present invention.

Electronics for the present invention can rely on software, hardware, or both to achieve a multi-frequency monitoring of total contact impedances of a biomedical electrode connected to both biomedical instrumentation and the skin of a patient.

Nonlimiting examples of ways to monitor total contact impedances of current flows can include electronic circuitry disclosed in the following U.S. Patents, but adapted by one skilled in the art for the purposes of this invention to monitor two different frequencies at various times: U.S. Pat. Nos. 5,422,567
5 (Matsunaga); 4,922,210 (Flachenecker et al.); 3,601,126 (Estes); 4,092,986 (Schneiderman); 4,281,373 (Mabille); 4,321,926 (Roge); 4,658,819 (Harris et al.); 4,727,874 (Bowers et al.); 4,860,745 (Farin et al.); 4,969,885 (Farin); and 4,102,341 (Ikuno et al.).

10 Usefulness of the Invention

Beyond the immediate utility to monitor lift of patient plates from skin of patients, this invention has a much broader application in other biomedical electrodes, or even beyond in other areas where additional information is desired about conduction across an interface.

15 For example, a biomedical electrode may be manufactured with a lossy dielectric coating located in certain areas that will “signal” whether those areas are effectively conducting electricity or have become disconnected in some way. The purpose of the lossy dielectric coating in such a biomedical electrode may not be to alter the current distribution in any way, but may simply serve as a
20 way of “signaling” that certain areas of the electrode are indeed conducting electricity.

Because this invention employs the special properties of lossy dielectric components in an electrical interface, the invention uses a material that inhabits a curious “no man’s zone” in that lossy dielectric surfaces are generally
25 regarded as having the properties of a badly defective resistor or capacitor that is totally unusable for the purpose that either component is designed for. As such, this invention can be a novel adaptation of an electrical phenomena that had up until now been regarded as a failure mode of other common devices.

Biomedical electrodes of the present invention can be electrically
30 connected to electrosurgical generators or cardiac stimulation devices to provide dispersive electrode connection or cardiac stimulation electrode connection,

respectively. Electrosurgical generators are commonly available and known to those skilled in the art, such as devices marketed by Birtcher Medical Systems, Inc. of Irvine, California; Aspen Surgical Systems, Inc. of Utica, New York; and Valleylab, Inc. of Boulder, Colorado. Cardiac stimulation devices for

5 cardioversion, external pacing, and defibrillation are commonly available and known to those skilled in the art, such as devices marketed by Hewlett-Packard Corporation of McMinnville, Oregon; Zoll Medical Corporation of Newton, Massachusetts; and Physiocontrol Corporation of Redmond, Washington. Any of these medical devices can be modified to include hardware and software

10 embodiments of this invention to provide a measurement of the difference of phase angle to advantage according to this invention.

While not being limited to particular theory, the following explanation provides evidence of the unexpectedness of the present invention.

For a plain biomedical electrode comprising a conductor surface and

15 a skin contacting agent such as a conductive adhesive, the total contact impedance is defined as the impedance between the conductor surface and the skin and/or tissues of the patient for the entire electrode as it is applied to the patient. This impedance is measured in ohms, rather than ohms/cm², because the contact impedance is always for the whole electrode surface, whatever that surface area

20 might be.

Total contact impedance for an electrode can be approximated in terms of finite element analysis by a series of resistors wired together in parallel, with each resistor representing the resistance of a small, discrete area of the total conductor surface. For a biomedical electrode with a surface area of 100 cm², the

25 total contact impedance could be represented by the sum of the resistances of 100 resistors wired in parallel, with each resistor representing the resistance of one unique and discrete square centimeter of the electrode's surface. The general equation for calculating the total impedance of a group of resistors wired in parallel is shown in Equation III:

30

$$1/R_{\text{total}} = 1/R_1 + 1/R_2 + 1/R_3 + 1/R_4 + \dots + 1/R_n \quad \text{III}$$

For a conventional, plain biomedical electrode without any lossy dielectric coating, the impedance value for each R_n will be equal, assuming that the conductor layer and adhesive layers are both of equal caliper and homogenous composition. For a plain biomedical electrode, the total contact impedance is inversely proportional to the number of elements of equal area used in the equation. Table 1 shows the calculation above done for a series of 1 - 10 finite elements, with each element having an resistance of 2 ohms. As can be seen, as the number of elements (of a fixed size) increases, the total contact impedance R_{TOTAL} goes down. Conversely, as the number of elements is decreased, the total contact impedance will rise. The number of elements in this hypothetical example can be made smaller in one of two ways:

- One can start out with an electrode of smaller surface area, or
- One could partially peel back the current electrode to create a smaller contact area with the patient's skin.

Table 1

Total No. of Elements	Resistance per Element	R_{TOTAL}
1	2	2.000
2	2	1.000
3	2	0.667
4	2	0.500
5	2	0.400
6	2	0.333
7	2	0.286
8	2	0.250
9	2	0.222
10	2	0.200

To demonstrate this hypothetical example in actual practice, a plain resistive electrode was made as follows: An electrode was constructed from a 99 cm² (15 square inches) of Aluminum foil having corners with a radius of 2.54 cm.

5 A layer of conductive adhesive was prepared according to the following procedure. Into a 300 gallon kettle equipped with overhead stirrer and a cooling jacket was charged 562.8 pounds (255.5 kg) acrylic acid, 1.4 pounds (636 grams) 2,2-dimethoxy-2-phenyl acetophenone, 2.8 pounds (1273 grams) 4-(2-hydroxyethoxy)phenyl-(2-hydroxy-2-methylpropyl)ketone, 1.12 pounds (508

10 grams) methylene bis(acrylamide), 1251.6 pounds (568.2 kg) glycerin, 2.8 pounds (1273 grams) guar gum, and 459.6 pounds (208.7 kg) deionized water. To the well stirred solution was charged 499.8 pounds (226.9 kg) 50% aqueous NaOH portionwise maintaining the batch temperature below 38°C. The hydroxide line was rinsed into the kettle with an additional 18 pounds (8.2 kg) deionized water and

15 stirred for 30 minutes to yield coater-ready precursor. The precursor was coated onto the foil side of a polyester/aluminum foil laminate at 23 mil (0.6 mm) thick, overlaminated with a siliconized polyester liner, and passed through a curing chamber consisting of banks of fluorescent "black" lights, exposing the material to an intensity of 1.9 mW/sqcm and a total dose of 315 mJ/sqcm. The layer of

20 conductive adhesive so prepared was then placed over the whole square of the electrically conductive surface.

Next, a series of four 45° diagonal lines was scribed on the back of two corners of the plate, starting 5mm in from the corner and repeating every 5mm. This electrode was placed on a human right anterior thigh. For comparison, a

25 commercial patient plate (3M No. 7149 Minnesota Mining and Manufacturing Company, St. Paul, MN) was placed on the human's left anterior thigh to act as a source of electricity flowing from another site to the location on the body where the dispersive electrode was located. An impedance scan utilizing a voltage of 60mV was then made from a frequency of 1 MHz down to 1 Hz using a

30 Schlumberger 1260 spectrum impedance analyzer. Next, the corner of the plate outside of the farthest line was cut off to simulate peeling the electrode back a very

precise distance (of 5mm or .197"), and another impedance scan was run. Then the remaining corner of the plate outboard of the second line was cut off, and another scan was run. This process was repeated a total of 8 times until a total of 2 cm. of material was cut off two corners of the plate. Next, a calculation was made of how much surface area was removed each time more of one of the corners was cut off. Table 2 shows the results.

Table 2

	Area in single cut	% of total area in single cut	Cumulative % of total plate cut off
1st cut	0.153	1.010	1.010
2nd cut	0.276	1.823	2.833
3rd cut	0.353	2.331	5.164
4th cut	0.429	2.833	7.998
5th cut	0.153	1.010	9.008
6th cut	0.276	1.823	10.831
7th cut	0.353	2.331	13.162
8th cut	0.429	2.833	15.995

10

Finally, a chart was drawn for the contact impedance of the plate at 1 MHz, 100 KHz, and 10 KHz, and was plotted against the cumulative % of surface area lost as the plate was progressively cut down. Fig. 3 shows the results, and as can be seen, there is an increase in the impedance at all three frequencies as the size of the plate is reduced. For convenient comparison to some trend lines calculated later on more significant data, 2nd order polynomial fits of the data are also shown on Fig. 3.

15

To further correlate this data with a theoretical model, the impedance of a 15 square inch plain Al foil plate was measured on a metal ground plane, and found to be 0.57 ohms. A calculation was then made based on dividing this 15 square inch area up into 200 elements (i.e., unit area) of 0.075 square inches each, and by use of back calculation with the equation for the sum of parallel resistive elements, the impedance for each element was found to be 114 ohms. The appropriate number of resistive elements were then subtracted to correspond to the

20

surface area that was actually cut off in the laboratory experiment, and the impedance was calculated for the finite element model with this smaller number of elements. Finally, this data was “aligned” on Fig. 3 with the 1 MHz data by adding 67.1 ohms to each calculated impedance so that the contact impedance of the 15 square inch plate on the metal ground plane would be the same as the impedance of that plate on the human. (In other words, the impedance of the human was assumed to be 67.1 ohms.)

The calculated data is shown below in tabular form of Table 3. The finite element model and the actual data agreed as the plain metal foil plate was progressively cut away. This fit was just as good if the intercept values of the other two lines (80.27 or 116.00) were added to the calculated data.

Table 3

Total # of Elements	Resistance per Element	R_{TOTAL}	$R_{TOTAL} + 67.1$
200	114	0.57000	67.670
198	114	0.57576	67.676
194	114	0.58763	67.688
190	114	0.60000	67.700
184	114	0.61957	67.720
182	114	0.62637	67.726
178	114	0.64045	67.740
174	114	0.65517	67.755
168	114	0.67857	67.779

This meant that the slight increase in impedance with decreasing surface area was not dependent on frequency. This was consistent with the fact that conventional plates using only Al foil and conductive adhesive are totally resistive in nature, since for an impedance value which is made up totally of resistance, (rather than resistance and reactance as is present with lossy dielectric material) there is no change in impedance as the frequency is varied.

The reason for the differences in total contact impedance between the three frequencies is due to the fact that human tissue is not purely a resistive conductor, so as the frequency of the current becomes lower the impedance of human tissue rises proportionately. This is partly why the contact impedance of a

patient plate may be less than 100 ohms at 1 MHz, while the contact impedance of an ECG electrode may be 500 Kilohms at 10 Hertz.

Next, this experiment was repeated for a Netherly patient plate prepared according to Example 56 of PCT Publication WO 97/37719 except that
5 the lossy dielectric material was Werneke Ultrafuse UFR Green, # UFGUB0008 from Werneke, Inc. of Plymouth, MN with a coating in three ring concentric stepped (0.10 inch wide) shading construction within the perimeter of the plate, and the data was plotted the same way and shown in Fig. 4. Fig. 4 demonstrates shows there is a drop in impedance as the corners of the patient plate are removed.

10 Moreover, it is evident that this decrease is not the same for the three frequencies shown. Thus, the method of present invention employs impedance measurements with interrogation at at least two different frequencies. The data in Fig. 4 shows three different frequencies used and total contact impedance as the percentage of the patient plate being removed from contact with a
15 patient's skin was increased.

To explain this performance, it must first be understood that not all points on a Netherly plate (which has a coating of lossy dielectric material at its
corners and edges) have the same impedance. As a matter of fact, the entire point of the Netherly plate is to create a higher impedance at the corners and edges of the
20 plate in order to lower the naturally high current densities that occur at these locations, and it has been established in extensive clinical testing that this goal is indeed met. Secondly, since this higher impedance is achieved by use of a lossy dielectric coating rather than a material which is either purely resistive or purely capacitive, the use of a finite element model based purely on parallel resistances is
25 not appropriate.

To briefly review, impedance is a vector quantity made up of resistance and reactance scalar terms. The impedance Z of the lossy dielectric material is made up of about 4 times as much Reactance X as Resistance R . Since the impedance of the lossy dielectric material is primarily due to the Reactance,
30 which is inversely proportional to the frequency, the impedance varies greatly with frequency.

The present invention has unexpectedly found edge effect present with all biomedical electrodes as they function while they are attached to human tissue, since edge effect is not dependent on the level of current used. This means that the current distribution will preferentially cluster at the corners and edges of a patient plate to the same degree for both a multi-hundred volt 1 amp surgical cutting current and a tiny 60 mV microampere sensing current from a Schlumberger 1260 impedance analyzer. When an impedance measurement is made on a patient plate while it is applied to human tissue, then, it is a fact that the sensing current is preferentially concentrated on the corners and edges of the plate. This means that the contact impedance of the plate as a whole is influenced more by the impedance at the edges and corners of the plate than the impedance at the center of the plate, since there is more electrical flow at the corners and edges of the plate than in the middle of it.

Now, for a normal Al foil plate where the entire conductive surface is isotropic (same impedance at every point on the plate...) this makes no difference, since the impedance at the corners is the same as in the middle of the plate. (Mathematically, this would be like taking the average of a group of numbers that all had the exact same value: There would be no difference between the average and any one of the individual numbers.) When the corner of a plain Al foil plate is lifted off a patient's skin, then, the only effect that is noted is a slight increase in impedance that is due to the overall reduction in surface area. The fact that it was the corner that was lifted rather than the center of the plate cannot be detected, since per unit area both the corner and the center of the plate have the same impedance, even if the current density at these two locations is very different.

For a Netherly patient plate having a lossy dielectric material, the impedance is not the same for the corners and the center of the plate, and the makeup of the total contact impedance is also quite different. The impedance at the center of the plate (where there is bare metal) is totally resistive, while the impedance in the lossy dielectric areas at the edges and the corners of the plate is about 4 times more capacitive (in the form of reactance) than resistive. While the lossy dielectric serves to force the current (either surgical or impedance sensing)

off the corners quite effectively, it is still a fact that a majority of the current is passing through the lossy dielectric portion of the plate. This means that as the contact impedance of a Netherly patient plate with a lossy dielectric material is measured on a human being, the concentration of sensing current in the high impedance areas of the plate is having a disproportionately large effect on the average impedance measurement for the whole plate.

As noted above, this is of no consequence for the measurement of contact impedance with a plain Al foil plate, for the reasons already stated. For a Netherly lossy dielectric patient plate, however, the impedance in the patient's tissues (which is the cause of corner and edge effect) forces more current through the high impedance pathways at the corners and edges of the Netherly lossy dielectric patient plate.

In other words, due to the high impedance in the patient's tissues across a distance of several inches, the edge and corner effect is overwhelming the natural tendency for either the surgical or impedance sensing current to follow the "normal" path of least resistance through the bare metal in the center of the plate. It is for this reason that a finite element model of a patient plate based on parallel resistances can simulate the performance of a normal Al foil plate so well, while it totally fails to duplicate the performance of a lossy dielectric patient plate.

As a consequence of this "forced" high impedance current flow through the corners and edges of a lossy dielectric patient plate, one would expect that the impedance measurement on a human test subject would be higher for that plate than for a corresponding 15 square inch Al foil plate. This is in fact the case, and the impedance data for both plates at three different frequencies shown in Table 4 below, as well as the difference between the two impedances.

Table 4

Frequency (Hz)	Lossy Dielectric Patient Plate Impedance (Ω)	Al Foil Patient Plate Impedance (Ω)	Difference in Impedances (Ω)
10^6	71.62	67.45	4.17
10^5	90.92	80.58	10.34

Frequency (Hz)	Lossy Dielectric Patient Plate Impedance (Ω)	Al Foil Patient Plate Impedance (Ω)	Difference in Impedances (Ω)
10^4	137.37	116.57	20.80

The present invention unexpectedly has found that the difference between the two impedances is not constant and that this difference is used in the method of the present invention.

5 Based on the previous explanation and data, a finite element model was constructed which fairly well duplicated the experimental performance of the lossy dielectric patient plate at all three frequencies. The model was made up of 200 elements as before, and those elements that represented the bare metal in the center of the plate are still treated as simple parallel resistors. Based on the total
10 area of bare metal in a 15 square inch solid (not split) plate being almost exactly 9 square inches, 119 out of the 200 elements were represented as being simple resistive elements. The other 81 elements were represented as being a combination of resistive and reactive elements, and the resistive part of each of these lossy dielectric elements was allowed to interact mathematically with the bare metal
15 elements in the center of the plate. The reactive part of these 81 elements, however, were treated differently in the calculation. To simulate the "forcing" of the sensing current through the high impedance lossy dielectric areas, the reactances were treated as being in series rather than parallel. (In other words, they were cumulatively added up to a total of however many reactive elements there
20 were for that simulation.) For the initial case where all 81 elements were present, the sum of this reactance is approximately equal to the difference between two of the total contact impedances shown above. In equation form, then, Equation IV below was developed to simulate the performance of the present invention.

$$25 \quad Z_{\text{total}} = X_1 + X_2 + X_3 + \dots + X_n + \frac{1}{1/R_{ld_1} + 1/R_{ld_2} + \dots + 1/R_{ld_n} + 1/R_{m_1} + \dots + 1/R_{m_{119}}}$$

IV

In the above Equation IV, X represents the Reactance of the lossy dielectric elements, R_{LD} represents the Resistance of the lossy dielectric elements, and R_M represents the resistance of the bare metal elements.

5 When this model was initially constructed, the ratio of reactance to resistance was kept at a constant ratio of 4 since this is what is seen in the electrical measurement of a uniform layer of lossy dielectric ink determined as described above. This resulted in R_{LD} values that were between 2 and 10 times larger than the value of 114 ohms selected for the bare metal, which seemed to
10 make sense on a physical level if one were comparing the purely resistive component of the lossy dielectric coating to the resistance of the bare metal. After this the reactances were adjusted to get the ends of the modeled data curves to line up with the real data, and the overall fit was passable. In an attempt to get the middle of the modeled curves to “sag” downwards to more closely agree with the
15 experimental data, some other R_{LD} values were chosen at random to see how this would affect the data. Surprisingly enough, the fit improved as the R_{LD} values were made smaller than the R_M values, and the fit improved until an R_{LD} value of .00001 ohms was reached.

 While it is quite unexpected to consider a system where the
20 resistance of a lossy dielectric element was 7 orders of magnitude smaller than a bare metal element, when the full sum of all the resistive terms was considered, there was an interesting physical interpretation of the resulting calculation. If a purely resistive plate were to be constructed where the impedance in the center of the plate was 114 ohms/unit of area, while the impedance around the corners and
25 edges of the plate was set at 1 ohm (or less)/unit of area, the current would be strongly forced to the corners and edges of the plate.

 In conclusion, then, when the values of this model were adjusted to give the best fit to the experimental data, the concept of a “forced” high impedance pathway appeared to drop out of the model as a matter of course.

30 The actual calculations are shown below in Table 4 for all three frequencies, and Fig. 4 also shows the modeled data superimposed on the graph of

the original experimental data.

Table 4

Total # of Lossy Dielectric Elements	1 MHz Reactance per Element	Resistance per Element	Total # of Bare Metal Elements	Resistance per Element	Z_{TOTAL}
81	0.0545	1	119	114	4.427
79	0.0545	1	119	114	4.318
75	0.0545	1	119	114	4.101
71	0.0545	1	119	114	3.883
65	0.0545	1	119	114	3.558
63	0.0545	1	119	114	3.449
59	0.0545	1	119	114	3.232
55	0.0545	1	119	114	3.015
49	0.0545	1	119	114	2.690
Total # of Lossy Dielectric Elements	100 KHz Reactance per Element	Resistance per Element	Total # of Bare Metal Elements	Resistance per Element	Z_{TOTAL}
81	0.19	1	119	114	15.402
79	0.19	1	119	114	15.022
75	0.19	1	119	114	14.263
71	0.19	1	119	114	13.504
65	0.19	1	119	114	12.365
63	0.19	1	119	114	11.986
59	0.19	1	119	114	11.227
55	0.19	1	119	114	10.468
49	0.19	1	119	114	9.330
Total # of Lossy Dielectric Elements	10 KHz Reactance per Element	Resistance per Element	Total # of Bare Metal Elements	Resistance per Element	Z_{TOTAL}
81	0.34	1	119	114	27.552
79	0.34	1	119	114	26.872
75	0.34	1	119	114	25.513
71	0.34	1	119	114	24.154
65	0.34	1	119	114	22.115
63	0.34	1	119	114	21.436
59	0.34	1	119	114	20.077
55	0.34	1	119	114	18.718
49	0.34	1	119	114	16.680

To use this phenomena to detect small amounts of corner lift with a
5 lossy dielectric patient plate, a CQM circuit can be constructed to monitor the total
contact impedance of the patient plate at two widely spaced frequencies, such as 1
MHz and 10 KHz) at various intervals of time. If a drop in impedance were noted
at 10 KHz that was not seen at 1MHz, this would be conclusive evidence that one
or more corners of the Netherly plate was becoming detached from the patient. If
10 a downward drift in both frequencies were noted, this would be interpreted as the
normal process of the plate becoming more securely adhered to the patient with
time, and thus the two phenomena could be easily differentiated by the CQM
circuit. This would also apply to any impedance rise associated with extensive
cooling of the patient's tissues, which occurs commonly with cardiovascular cases.
15 In addition, all CQM generators are already set up to monitor impedance at one
frequency between 10 KHz and 1MHz. While their present circuit design does this
by use of a small, clean AC signal that is only activated when the generator is not
actively cutting, there is known in the art to be able to detect impedance changes
"through" the noise of the actual surgical arc itself. In order to implement
20 automatic coagulation in either the monopolar or bipolar mode with a generator,
this technical obstacle must be overcome, and both the Valleylab FX and the Erbe
ICC 350 generators currently offer this modality with their systems. One skilled in
the art of circuitry design can include the benefits of Equation I above into the
CQM generator to establish both an apparatus for the present invention and the
25 means to implement the method of the present invention using the teachings of the
U.S. Pat. Nos. U.S. Pat. Nos. 5,422,567 (Matsunaga); 4,922,210 (Flachenecker et
al.); 3,601,126 (Estes); 4,092,986 (Schneiderman); 4,281,373 (Mabille); 4,321,926
(Roge); 4,658,819 (Harris et al.); 4,727,874 (Bowers et al.); 4,860,745 (Farin et
al.); 4,969,885 (Farin); and 4,102,341 (Ikuno et al.).

30 One advantage of the present method over the method using a shift
in phase angle is that the magnitude of the impedance change that must be detected

is considerably larger than the magnitude of the phase shift that must be detected. However, it is an option of the present invention to use both methods for cross-correlation if so desired. For phase shift detection a precision of + 0.1 degrees (out of 360) is desirable, while for impedance detection a precision of 1 ohm (out
5 of 100) at 1 MHz and/or a precision of 3 ohms (out of 200) at 10 KHz is desirable. Finally, measurement of impedance changes at two frequencies can be viewed as a much more "static" process, compared to the challenge of measuring small shifts in the phase angle of an alternating current that is changing phase at the rate of 180,000,000 degrees (360 X 500 KHz) per second.

10 Various modifications and alterations of the present invention will be apparent to those skilled in the art without departing from the scope and spirit of this invention, and it should be understood that this invention is not limited to the illustrative embodiments set forth herein. The claims follow.

What is claimed is:

1. A method of detecting loss of contact between a biomedical electrode and skin of a patient, comprising the steps of:

5 (a) detecting total contact impedance of the electrode using two different frequencies to establish two initial total contact impedances;

(b) detecting two total contact impedances of the electrode using the same frequencies as in step (a) at at least one later time to establish two differences in total contact impedance, one difference for each frequency; and

10 (b) sounding an alarm when the ratio of change of the contact impedances exceeds a predetermined amount.

2. A method of quantifying lift off of a biomedical electrode from skin of a patient, by the use of the equation:

15
$$\text{Degree of Lift} = (Z_{f1t0} - Z_{f1t1}) / (Z_{f2t0} - Z_{f2t1})$$

where Z denotes a total contact impedance of the biomedical electrode, f1 denotes a first impedance measurement frequency, f2 denotes a second impedance measurement frequency, t0 denotes a first (or initial) impedance measurement time, and t1 denotes a impedance measurement at some later time, comprising the steps of (a) measuring two initial total contact impedances using two different frequencies, (b) measuring two later time total contact impedances using the same two frequencies as in step (a) and using the equation to obtain a ratio of change of the two total contact impedances; and (c) sounding an alarm when the ratio of change of the two total contact impedances exceeds a certain set value.

25

3. A method of determining the amount of skin contact between a biomedical electrode and skin of a patient, comprising the steps of:

(a) measuring the ratio of the change of two total contact impedances, measured at different frequencies, over time of an energized biomedical electrode; and

30

(b) sounding an alarm when the ratio of the change of the total contact impedances over time exceeds a predetermined amount.

4. An apparatus for detecting loss of contact between a biomedical
5 electrode and skin of a patient, comprising:

(a) a biomedical electrode having an electrical conductor having at least a portion thereof having lossy dielectric properties; and

(b) means for detecting when a ratio in the change of total contact impedances measured at two different frequencies over time exceeds a
10 predetermined amount.

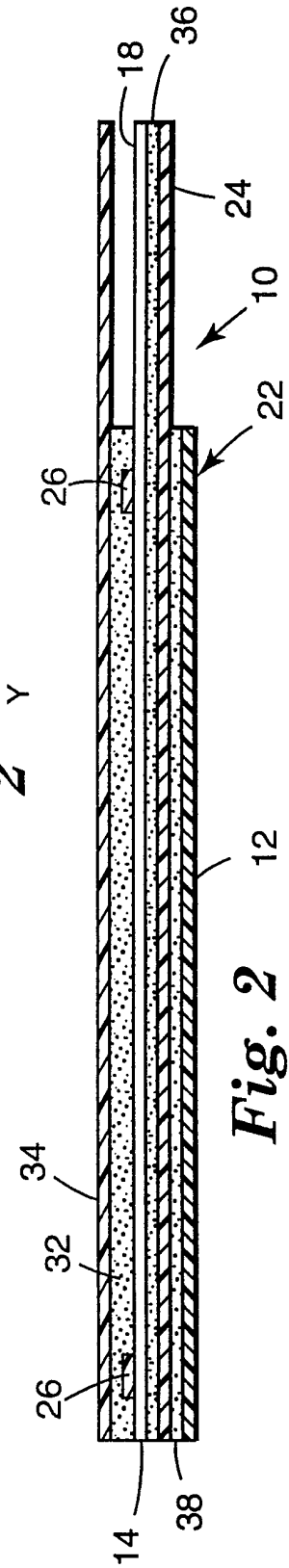
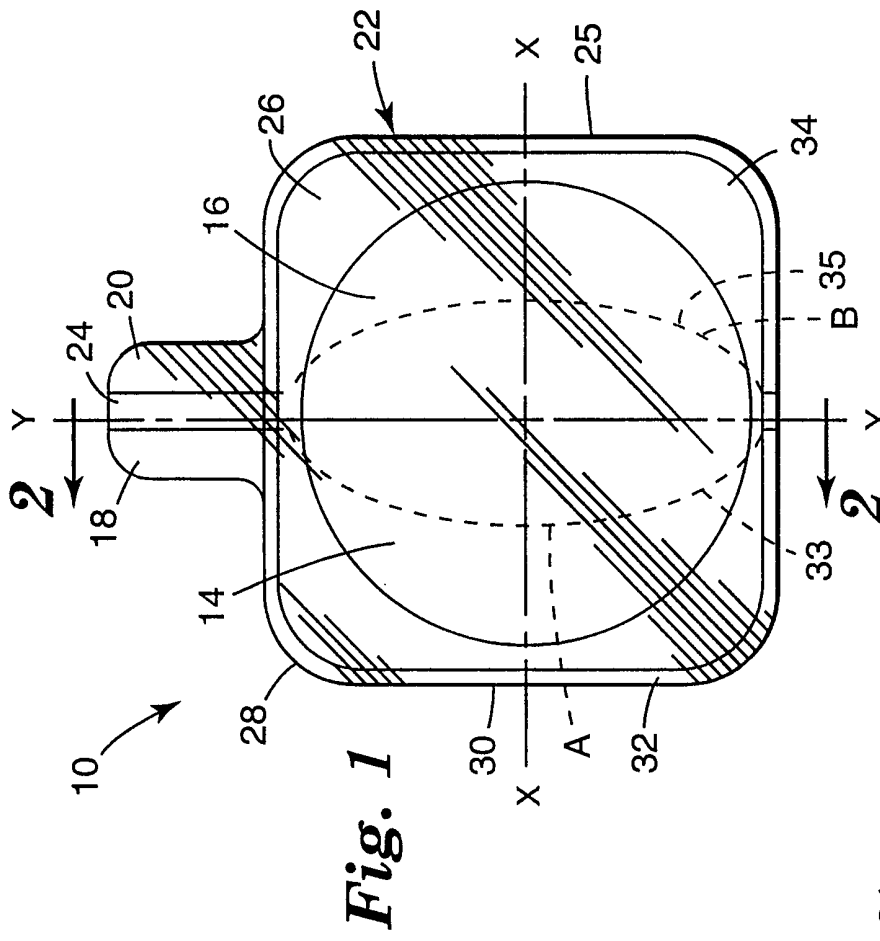

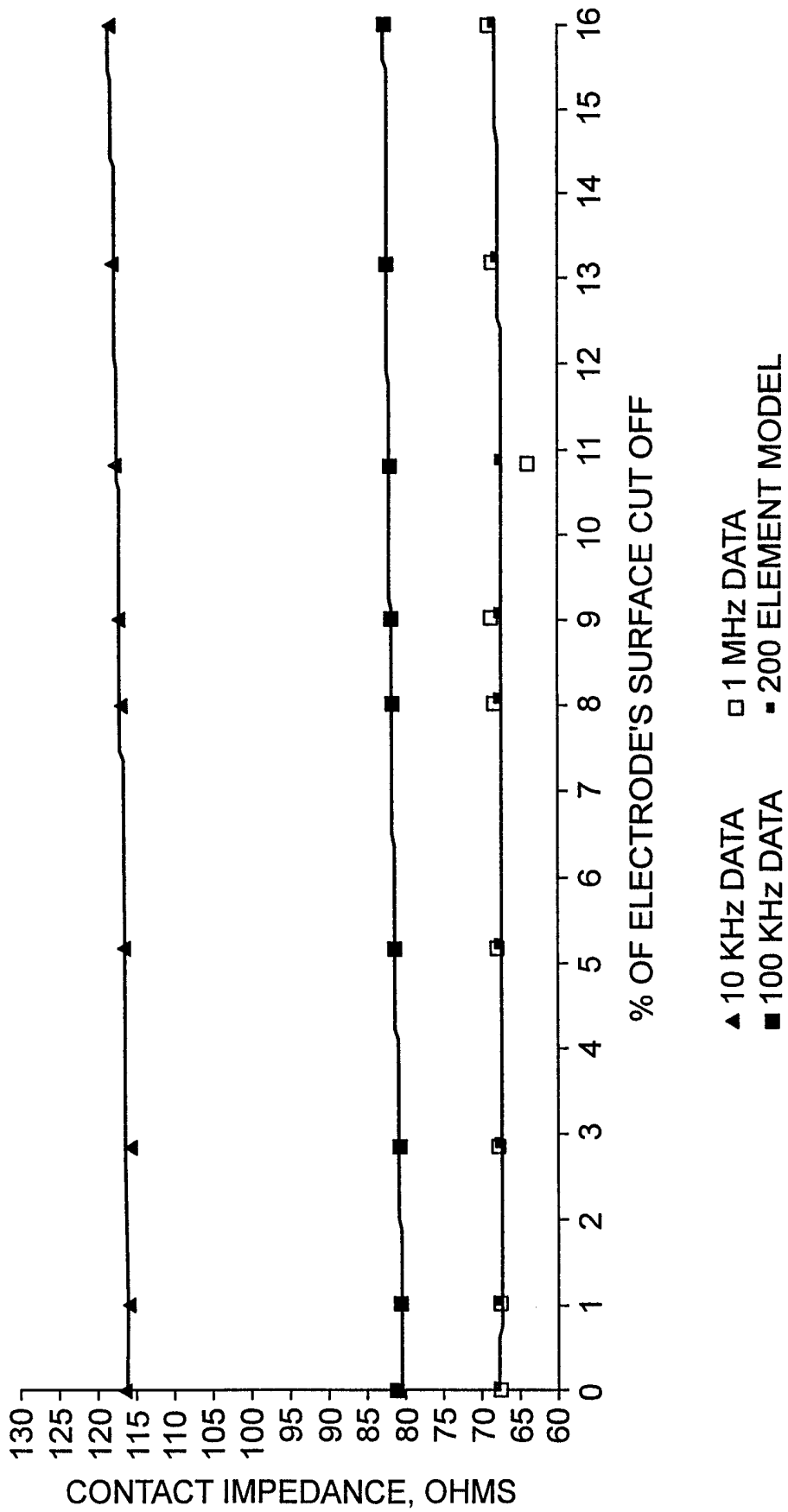

Fig. 3

INTERNATIONAL SEARCH REPORT

International Application No
PCT/US 97/24106

A. CLASSIFICATION OF SUBJECT MATTER IPC 6 A61B17/39 A61B5/0424 A61N1/08		
According to International Patent Classification (IPC) or to both national classification and IPC		
B. FIELDS SEARCHED		
Minimum documentation searched (classification system followed by classification symbols) IPC 6 A61B A61N		
Documentation searched other than minimum documentation to the extent that such documents are included in the fields searched		
Electronic data base consulted during the international search (name of data base and, where practical, search terms used)		
C. DOCUMENTS CONSIDERED TO BE RELEVANT		
Category	Citation of document, with indication, where appropriate, of the relevant passages	Relevant to claim No.
A	US 4 141 351 A (JAMES GORDON W ET AL) 27 February 1979 see column 1, line 38 - line 55; claim 1 ---	1-4
A	WO 96 19152 A (VALLEYLAB INC) 27 June 1996 see page 2, line 15 - page 6, line 9 ---	1-4
A	US 4 200 104 A (HARRIS FRANK W) 29 April 1980 cited in the application see column 1, line 7 - column 2, line 29 ---	1-4
A	US 5 087 257 A (FARIN GUENTER ET AL) 11 February 1992 see column 2, line 27 - column 5, line 38 --- -/--	1-4
<input checked="" type="checkbox"/> Further documents are listed in the continuation of box C.		
<input checked="" type="checkbox"/> Patent family members are listed in annex.		
° Special categories of cited documents :		
"A" document defining the general state of the art which is not considered to be of particular relevance	"T" later document published after the international filing date or priority date and not in conflict with the application but cited to understand the principle or theory underlying the invention	
"E" earlier document but published on or after the international filing date	"X" document of particular relevance; the claimed invention cannot be considered novel or cannot be considered to involve an inventive step when the document is taken alone	
"L" document which may throw doubts on priority claim(s) or which is cited to establish the publication date of another citation or other special reason (as specified)	"Y" document of particular relevance; the claimed invention cannot be considered to involve an inventive step when the document is combined with one or more other such documents, such combination being obvious to a person skilled in the art.	
"O" document referring to an oral disclosure, use, exhibition or other means	"&" document member of the same patent family	
"P" document published prior to the international filing date but later than the priority date claimed		
Date of the actual completion of the international search <p style="text-align: center;">15 May 1998</p>	Date of mailing of the international search report <p style="text-align: center;">25/05/1998</p>	
Name and mailing address of the ISA European Patent Office, P.B. 5818 Patentlaan 2 NL - 2280 HV Rijswijk Tel. (+31-70) 340-2040, Tx. 31 651 epo nl, Fax: (+31-70) 340-3016	Authorized officer <p style="text-align: center;">Petter, E</p>	

INTERNATIONAL SEARCH REPORT

International Application No
PCT/US 97/24106

C.(Continuation) DOCUMENTS CONSIDERED TO BE RELEVANT		
Category	Citation of document, with indication, where appropriate, of the relevant passages	Relevant to claim No.
A	US 4 793 362 A (TEDNER B0) 27 December 1988 see the whole document -----	1-4

INTERNATIONAL SEARCH REPORT

information on patent family members

International Application No

PCT/US 97/24106

Patent document cited in search report	Publication date	Patent family member(s)	Publication date
US 4141351 A	27-02-1979	NONE	
WO 9619152 A	27-06-1996	US 5695494 A	09-12-1997
		AU 3879895 A	10-07-1996
		DE 29580748 U	11-09-1997
		JP 10500605 T	20-01-1998
US 4200104 A	29-04-1980	DE 2849422 A	23-05-1979
		FR 2409487 A	15-06-1979
		JP 54078885 A	23-06-1979
US 5087257 A	11-02-1992	EP 0390937 A	10-10-1990
		DE 58908600 D	08-12-1994
US 4793362 A	27-12-1988	SE 455043 B	20-06-1988
		EP 0106867 A	02-05-1984
		SE 8202533 A	23-10-1983
		WO 8303746 A	10-11-1983