

Aug. 8, 1961

L. M. FINK

2,995,120

METHOD OF AND APPARATUS FOR SUPERHEATING VAPOR

Filed Aug. 1, 1958

2 Sheets-Sheet 1

FIG. 2

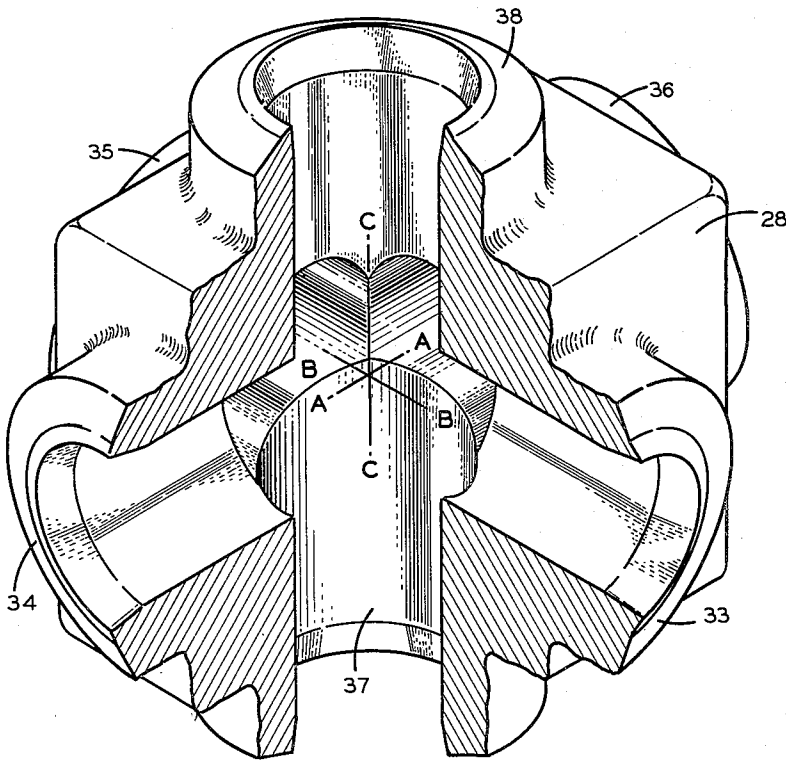
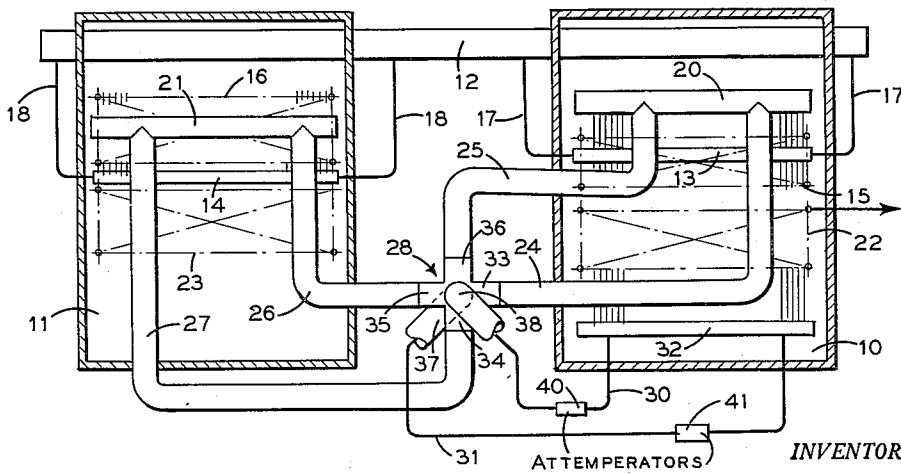

FIG. 1



INVENTOR.

Leroy M. Fink

BY

ATTORNEY

Aug. 8, 1961

L. M. FINK

2,995,120

METHOD OF AND APPARATUS FOR SUPERHEATING VAPOR

Filed Aug. 1, 1958

2 Sheets-Sheet 2

FIG. 3

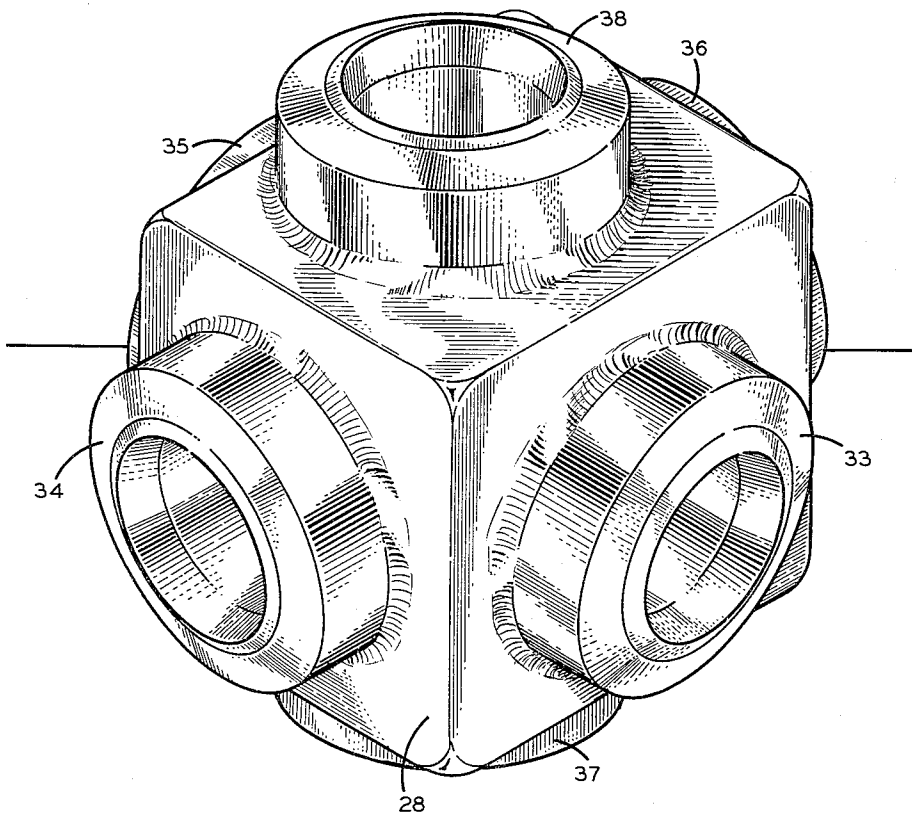

INVENTOR.

Leroy M. Fink

BY

ATTORNEY

1

2,995,120

METHOD OF AND APPARATUS FOR SUPERHEATING VAPOR

Leroy M. Fink, Union, N.J., assignor to The Babcock & Wilcox Company, New York, N.Y., a corporation of New Jersey

Filed Aug. 1, 1958, Ser. No. 752,547

4 Claims. (Cl. 122-476)

2

posed in the flow path of heating gases from each of the furnaces 10 and 11. The steam delivered to the superheaters is divided for parallel flow through the separate primary superheater elements. The partially heated steam is collected in separate headers 20 and 21 and is thereafter delivered to a secondary superheater 22 positioned in the flow path of the gases from the furnace 10. Commonly, reheater steam elements 23 are positioned in the gas pass of the other furnace 11.

Due to the high capacity of the unit of the type described, the headers 20 and 21 collecting the superheated steam from the primary superheaters 14 and 15 are large and are commonly provided with at least two steam outlet pipes such as 24, 25, 26 and 27. As shown particularly in FIG. 1, the four pipes 24 to 27, inclusive, are connected with steam inlet nozzles opening to the distributor casing 28 of the present invention. After leaving the distributor, the steam is passed through outlet nozzles to a pair of pipes 30 and 31 which open to the inlet header 32 of the secondary superheater 22.

Since the operations of the twin furnace unit are not only utilized to generate and superheat the steam used in a prime mover such as a steam turbine but also to control the reheat temperature of the steam delivered to an intermediate stage of the steam turbine, the heating effect of the gases passing through the separate heating gas flow paths may differ and thus the temperature of the superheated steam discharged from the primary superheater outlet headers 20 and 21 will also differ. Under these circumstances, it is desirable to apportion the steam delivered from the primary superheater elements so that the two streams of steam delivered to inlet header 32 of the secondary superheater 22 will be substantially equal.

This objective is attained in the distributor of the present invention by application of the laws of symmetry. As shown in FIGS. 1, 2 and 3, the four pipes 24 to 27, inclusive, delivering steam to the distributor casing 28 each open to a steam inlet nozzle 33 to 36, inclusive, where each nozzle is positioned with its axis lying in a common plane. The four inlet nozzles are circumferentially equally spaced in a common plane so that the streams of steam discharging from each of the nozzles impinges directly upon the steam injected from the other three inlet nozzles.

As shown in FIGS. 1 and 2, the distributor casing 28 or housing is provided with outlet nozzles 37 and 38 at opposite ends thereof where the nozzles are coaxial with a longitudinal axis of the casing and perpendicular to the plane of the axes of the inlet nozzles 33 to 36. With this arrangement, the steam entering each of the inlet nozzles is equally divided to flow through each of the outlet nozzles 37 and 38. Thus, each of the outlet pipes 30 and 31 connected with the header 32 of the secondary superheater 22 receives its proportionate quantity of the total steam entering the distributor casing. Moreover, any difference in the quantity of steam entering the distributor from the separate inlet nozzles is proportionately discharged to the two outlet nozzles. Thus, the steam discharged toward the inlet header of the secondary superheater is proportionately distributed to the secondary superheater inlet header 32.

With the construction described, little, if any, mixing of the separate streams of steam occurs within the distributor casing. The steam passing through the discharge pipes, however, is effectively mixed and distributed in the attemperators 40 and 41 (see FIG. 1) positioned in the pipes 30, 31 leading to the secondary superheater inlet header 32. By use of attemperators, the temperature of the steam delivered to the secondary superheater can be accurately and conveniently regulated to control the temperature of the steam discharged from the superheater elements for subsequent delivery to the prime mover.

The present invention relates in general to the superheating of vapor at high temperatures and pressures, and more particularly to a method of and apparatus for distributing the flow of superheating vapor between primary superheaters arranged in parallel and a common secondary superheating section.

With the rapid increase in the size of high pressure steam generating and superheating units and the use of high superheat and reheat temperatures, separate, such as divided or twin, furnace constructions have been used where the temperatures of the steam discharging from primary superheaters in separate gas flow paths having different heating capabilities result in different temperatures, densities and mass flow characteristics of the steam. Thus, when the partially superheated steam is delivered to secondary superheating elements, the equable distribution of flow of the steam to the elements becomes important to effect uniformity of heat absorption in the elements and the discharge of steam at controlled temperatures to the prime mover.

In accordance with my present invention, I provide a simple and effective steam distributing device interposed between the primary and secondary superheaters of a steam power generating unit so as to equalize the distribution of steam to the secondary superheater. This distributing device effectively utilizes symmetrically arranged impinging jets to apportion the distribution of the entering streams to the discharge pipes leading toward the secondary superheater. The steam is subsequently thoroughly mixed for temperature equalization prior to delivery to the secondary superheater.

The various features of novelty which characterize my invention are pointed out with particularity in the claims annexed to and forming a part of this specification. For a better understanding of the invention, its operating advantages and specific objects attained by its use, reference should be had to the accompanying drawings and descriptive matter in which I have illustrated and described a preferred embodiment of the invention.

Of the drawings:

FIG. 1 is a schematic illustration of the application of the distributor of the present invention in a twin furnace vapor generator;

FIG. 2 is a perspective view, partly in section, of the distributor, shown in FIG. 3; and

FIG. 3 is an exterior perspective view of the distributor of the present invention.

The schematic showing of a twin furnace vapor generator shown in FIG. 1 includes separate furnaces 10 and 11 where each furnace is separately fired by a suitable fuel for the production of heating gases. The walls of the furnace are preferably lined by vapor generating tubes (not shown) which are connected into the circulating system of the vapor generator.

As is usual in twin furnace construction, or in divided furnace, the vapor produced in the vapor generating tubes of the furnaces is discharged to a common steam and water drum 12. Thereafter, the saturated steam is passed from the steam and water drum 12 into the inlet headers 13 and 14 of primary superheating elements 15 and 16 through the connecting pipes 17 and 18.

The primary superheating elements 15 and 16 are dis-

In the embodiment of the invention shown in the drawings the inlet nozzles 33 to 36 are equally spaced circumferentially of the distributor casing 28 with the axes A—A, B—B of the nozzles lying in a common plane and with these axes intersecting a longitudinal axis C—C of the casing. The outlet nozzles are coaxial with the longitudinal axis of the casing and are perpendicular to the plane of the axes of the inlet nozzles. Due to the symmetry of the construction, the fluid stream passing through each of the inlet nozzles will be substantially equally divided to discharge through the outlet nozzles 37 and 38. Thus, even though the quantity entering the distributor casing 28 through each of the inlet nozzles may differ widely, the streams will be substantially equally divided to the outlet nozzles 37 and 38, and the total flow through each of the outlet nozzles will be substantially equal.

Modifications in the distributor arrangement may be made without adversely changing the distributing effect, providing two or more inlet nozzles are used with the nozzles circumferentially equally spaced about the longitudinal axis of the casing and having the axis of each inlet nozzle intersecting the longitudinal axis of the casing at a common point and lying in a common plane perpendicular to the axis of the outlet nozzles. Proportional distribution of fluid flow from a distributor can also be obtained if the axes of the inlet nozzles are uniformly circumferentially spaced and lie on the surface of a right circular cone which has its apex on the longitudinal axis of the outlet nozzles. The proportionality of flow to the two outlet nozzles will then be dependent upon the cone angle of the right circular cone on which the inlet nozzle axes lie.

By way of example, the inlet nozzles 33 to 36 may have an internal diameter of 11.25 inches, the outlet nozzles 37 and 38 may each have an internal diameter of 14.25 inches, and as much as 2,400,000 pounds of steam per hour may pass through the distributor.

While in accordance with the provisions of the statutes I have illustrated and described herein the best form and mode of operation of the invention now known to me, those skilled in the art will understand that changes may be made in the form of the apparatus disclosed without departing from the spirit of the invention covered by my claims, and that certain features of my invention may sometimes be used to advantage without a corresponding use of other features.

What is claimed is:

1. In steam generating and superheating apparatus, the combination comprising walls defining separate furnaces, means for burning fuel in said furnaces to generate heating gases, separate gas flow paths leaving said furnaces, means for generating steam, primary steam superheating elements disposed in said separate gas flow paths, means for passing steam in parallel to said primary superheating elements, a secondary steam superheater positioned in one of said gas flow paths, and separate means positioned between and effective for collecting the steam from said primary superheater elements and discharging proportionately distributed streams of steam to said secondary superheater including a casing, outlet nozzles coaxial with an axis of and on opposite sides of said casing, said outlet nozzles connected by a flow passageway through said casing and having a cross-sectional flow area substantially equal to that of an outlet nozzle, and a plurality of inlet nozzles symmetrically spaced about the axis of said casing and opening to said flow passageway, the axes of said inlet nozzles lying in a plane normal to the axes of said outlet nozzles with each of said inlet nozzle axes intersecting said casing axis, whereby the steam flow from each of said inlet nozzles is divided on entering said flow passageway and discharged to said pair of outlet nozzles.

2. In steam generating and superheating apparatus, the combination comprising walls defining separate fur-

naces, means for burning fuel in said separate furnaces to generate heating gases, separate gas flow paths leaving said furnaces, means for generating steam, primary steam superheating elements disposed in said separate gas flow paths, means for passing steam to said primary superheating elements, a secondary steam superheater positioned in one of said gas flow paths and having an elongated steam inlet header, and separate means positioned between and effective for collecting the steam from said primary superheater elements and discharging proportionately distributed streams of steam to said secondary superheater at spaced points symmetrically arranged longitudinally of said inlet header including a casing, outlet nozzles coaxial with an axis of and on opposite sides of said casing, said outlet nozzles connected by a flow passageway through said casing and having a cross-sectional flow area substantially equal to that of an outlet nozzle, and a plurality of inlet nozzles symmetrically spaced about the axis of said casing and opening to said flow passageway, the axes of said inlet nozzles lying in a plane normal to the axes of said outlet nozzles with each of said inlet nozzle axes intersecting said casing axis, whereby the steam flow from each of said inlet nozzles is divided on entering said flow passageway and discharged to said pair of outlet nozzles.

3. In steam generating and superheating apparatus, the combination comprising walls defining separate furnaces, said walls including steam generating tubes opening to a common steam and water drum, means for burning fuel in said furnaces to generate heating gases, separate gas flow paths leaving said furnaces, primary steam superheating elements disposed in said separate gas flow paths, means for passing steam in parallel from said steam and water drum to said primary superheating elements, a secondary steam superheater positioned in one of said gas flow paths and having an elongated steam inlet header, and separate means positioned between and effective for collecting the steam from said primary superheater elements and discharging proportionately distributed streams of steam to said secondary superheater at spaced points symmetrically arranged longitudinally of said inlet header including a casing, outlet nozzles coaxial with an axis of and on opposite sides of said casing, said outlet nozzles connected by a flow passageway through said casing and having a cross-sectional flow area substantially equal to that of an outlet nozzle, and a plurality of inlet nozzles symmetrically spaced about the axis of said casing and opening to said flow passageway, the axes of said inlet nozzles lying in a plane normal to the axes of said outlet nozzles with each of said inlet nozzle axes intersecting said casing axis, whereby the steam flow from each of said inlet nozzles is divided on entering said flow passageway and discharged to said pair of outlet nozzles.

4. In steam generating and superheating apparatus, the combination comprising walls defining separate furnaces, said walls including steam generating tubes opening to a common steam and water drum, means for burning fuel in said furnaces to generate heating gases, separate gas flow paths leaving said furnaces, primary steam superheating elements disposed in said separate gas flow paths, a separate outlet header for each of said primary superheating elements, means for passing steam in parallel from said steam and water drum to said primary superheating elements, a secondary steam superheater positioned in one of said gas flow paths and having an elongated steam inlet header, and separate means positioned between and effective for collecting the steam from the separate outlet headers of said primary superheater elements and discharging proportionately distributed streams of steam to said secondary superheater at spaced points symmetrically arranged longitudinally of said inlet header including a casing, outlet nozzles coaxial with an axis of and on opposite sides of said casing, said outlet nozzles connected by a cylindrical flow passageway

5

through said casing and having a cross-sectional flow area substantially equal to that of an outlet nozzle, and a plurality of inlet nozzles symmetrically spaced about the axis of said casing and opening to said flow passageway, the axes of said inlet nozzles lying in a plane normal to the axes of said outlet nozzles with each of said inlet nozzle axes intersecting said casing axis, the total cross-section flow area of all of said inlet nozzles being generally equal to the total cross-section flow area of all of said outlet nozzles, whereby the steam flow from each of said inlet nozzles is continually divided on entering

5

10

6

said flow passageway and discharged to said pair of outlet nozzles.

References Cited in the file of this patent

UNITED STATES PATENTS

872,338	Gold	Dec. 3, 1907
1,577,549	Winslow	Mar. 23, 1926
2,781,746	Armacost et al.	Feb. 19, 1957

FOREIGN PATENTS

543,170	Canada	July 9, 1957
---------	--------	--------------