

(19)



(11)

EP 1 386 876 B1

(12)

EUROPEAN PATENT SPECIFICATION

(45) Date of publication and mention of the grant of the patent:

14.05.2014 Bulletin 2014/20

(51) Int Cl.:

B66B 11/02^(2006.01) B66B 5/00^(2006.01)

(21) Application number: **01919968.6**

(86) International application number:

PCT/JP2001/003264

(22) Date of filing: **17.04.2001**

(87) International publication number:

WO 2002/085773 (31.10.2002 Gazette 2002/44)

(54) **ELEVATOR CAGE AND ELEVATOR**

AUFZUGSKÄFIG UND AUFZUG

Barrière de sécurité pour ascenseur

(84) Designated Contracting States:
DE FR NL

(74) Representative: **HOFFMANN EITLE**
Patent- und Rechtsanwälte
Arabellastrasse 4
81925 München (DE)

(43) Date of publication of application:
04.02.2004 Bulletin 2004/06

(73) Proprietor: **mitsubishi denki kabushiki**
KAISHA
Chiyoda-ku
Tokyo 100-8310 (JP)

(56) References cited:

EP-A- 0 985 628 EP-A- 1 346 942
WO-A-03/020629 WO-A-03/093157
WO-A-03/095350 WO-A-2004/000713
JP-A- 2000 143 125 JP-U- 63 197 261
JP-Y2- 6 049 577

(72) Inventor: **SHITAMIYA, Koji,**
Mitsubishi Denki Kabushiki Kaisha
Chiyoda-ku, Tokyo 100-8310 (JP)

- **PATENT ABSTRACTS OF JAPAN vol. 1997, no. 03, 31 March 1997 (1997-03-31) & JP 08 310771 A (MITSUBISHI DENKI BILL TECHNO SERVICEKK), 26 November 1996 (1996-11-26)**

EP 1 386 876 B1

Note: Within nine months of the publication of the mention of the grant of the European patent in the European Patent Bulletin, any person may give notice to the European Patent Office of opposition to that patent, in accordance with the Implementing Regulations. Notice of opposition shall not be deemed to have been filed until the opposition fee has been paid. (Art. 99(1) European Patent Convention).

Description

Field of the Invention

[0001] The present invention relates to an elevator cage, and more particularly, to an elevator cage on which is provided a safety fence for protecting a service technician at the time of maintenance and inspection of an elevator system.

[0002] EP-A-0 985 628 discloses in combination the technical features of the pre-characterizing part of claims 1 and 2 below.

Background Art

[0003] There has hitherto been known an elevator cage on which is provided a fold-down safety fence to be used at the time of maintenance and inspection of an elevator system.

[0004] A known elevator cage will be described by reference to Fig. 5a, Fig. 5b and Fig. 5c. Fig. 5a is a perspective view showing the state of a known elevator system at the time of maintenance and inspection, and Fig. 5b is a side view showing the same. As illustrated, a safety fence provided on a cage top 1a of an elevator cage 1 primarily comprises support members 3; front and rear pillar members 4a, 4b; handrail members 5; and arm members 6.

[0005] Here, the support members 3 are fixedly provided on the cage top 1a. An end of each front pillar member 4a is pivotally joined to the center of the respective support member 3 by means of a pin. An end of each rear pillar member 4b is pivotally joined to one end of the respective support member 3 by means of a pin. One end of the handrail member 5 is pivotally joined to the remaining end of the respective front pillar member 4a by means of a pin. The other end of the handrail member 5 is pivotally joined to the remaining end of the respective rear pillar member 4b by means of a pin, in order to join the two pillar members 4b together. Further, one end of each arm member 6 is pivotally joined to the center of the respective rear pillar member 4b by means of a pin. The other end of each arm member 6 is pivotally joined, by means of a pin, to a position on the respective support member 3 closer to the rear pillar member 4b with reference to the center of the support member 3.

[0006] Here, each arm member 6 is primarily constituted of two plate members joined together by means of a pin, and a stopper provided in a position close to the pin for limiting pivotal movement of the two plate members. At the time of maintenance and inspection of an elevator system, a service technician first gets on the cage top 1a from the side of the elevator cage 1 on which a door 2 is provided. The safety fence is then raised, and pivotal movement of the two plate members of each arm member 6 is limited by means of the respective stopper, whereupon pivotal movement of the other members is also limited. As a result, the service technician can per-

form a desired operation while being protected by the safety fence and from a fall.

[0007] Fig. 5c is a side view showing a normal state of the known elevator cage. As illustrated, the safety fence is collapsed for ensuring space above the elevator cage 1 during a normal operation other than the maintenance and inspection operation. More specifically, the stopper of each arm member 6 is disengaged, thereby rendering the two plates pivotable about the pin. As a result, the respective members also become pivotable about their corresponding pins, and the safety fence is collapsed.

[0008] However, such a known elevator cage is collapsed two-dimensionally with respect to the cage top 1a. Therefore, the service technician can readily get on the cage top 1a without raising the safety fence. There may still remain a situation of an inability to prevent falling of a service technician from an elevator cage without fail.

[0009] The invention aims at solving such a situation of the known elevator cage and at providing an elevator cage which enables a service technician to raise a safety fence without fail at the time of maintenance and inspection, to thereby prevent falling of the service technician from the elevator cage without fail.

Disclosure of the Invention

[0010] The present invention relates to an elevator cage having a fixing member removably attached to a safety fence to be assembled on a cage top, wherein the fixing member is fixed to a position close to a doorway when the safety fence is folded down. As a result, when performing maintenance and inspection, a service technician removes the fixing member to get on the cage top and assembles the safety fence through use of the fixing member, thereby avoiding a chance of the service technician performing an operation without assembling the safety fence.

[0011] The invention also relates to an elevator cage having a safety fence to be assembled on a cage top of an elevator cage, the safety fence having pillar members and handrail members, wherein the handrail members are pivotally joined to the pillar members such that a doorway is interrupted when the handrail members are folded down. As a result, the service technician raises the handrail members for getting on the cage top at the time of maintenance and inspection, to thereby assemble the safety fence. Hence, there can be avoided a chance of the service technician performing an operation without assembling the safety fence.

[0012] The invention also relates to an elevator cage based on the previous improved elevator cage, wherein stoppers are provided on the respective pillar members for limiting a rotation angle of the handrail members. As a result, the handrail members are folded down to arbitrary positions except at the time of maintenance and inspection, thereby thoroughly preventing the service technician from getting on the cage top.

[0013] The invention further relates to an elevator cage

based on the previous improved elevator cage, wherein the handrail members are constructed so as to cover the cage top when folded down. When the handrail members are folded down, no scaffold is ensured for the service technician, thereby preventing the service technician from standing upright. Hence, the service technician can be prevented from performing an operation with the handrail sections collapsed.

Brief Description of the Drawings

[0014]

Fig. 1a and Fig. 1b are perspective views showing a preferable elevator cage according to a first embodiment of the invention at the time of maintenance and inspection and at normal times.

Fig. 2a and Fig. 2b are perspective views showing a preferable elevator cage according to a second embodiment of the invention at the time of maintenance and inspection and at normal times.

Fig. 3a and Fig. 3b are perspective views showing a preferable elevator cage according to a third embodiment of the invention at the time of maintenance and inspection and at normal times.

Fig. 4a and Fig. 4b are perspective views showing a preferable elevator cage according to a fourth embodiment of the invention at the time of maintenance and inspection and at normal times.

Fig. 5a and Fig. 5b are perspective view and side view showing a conventional elevator cage at the time of maintenance and inspection and at normal times, and Fig. 5c is a side view showing a conventional elevator cage at normal times.

Modes for Implementing the Invention

[0015] The invention will be described in more detail in accordance with the accompanying drawings.

[0016] Fig. 1a and Fig. 1b are perspective views showing an elevator cage (i.e., an elevator car) according to a first embodiment of the invention. Specifically, Fig. 1a is a perspective view showing the state of the elevator cage of the first embodiment at the time of maintenance and inspection, and Fig. 1b is a perspective view of the elevator cage of the first embodiment in normal times.

[0017] As shown in Figs. 1a and 1b, reference numeral 1 designates an elevator cage. Passengers get on and off or cargo is loaded or unloaded into the elevator cage by way of a door 2 (a doorway' of the car).

[0018] Reference numeral 1a designates a cage top of the elevator cage 1. A fold-down safety fence (i.e., a handrail device disposed on a car top) is provided on the cage top 1a (i.e., outside the cage). The cage top 1a is formed flat so that a service technician can get on the cage top 1a to perform a maintenance and inspection operation.

[0019] The safety fence provided on the cage top 1a

is primarily constituted of pillar members 9, handrail members 7, and a fixing member 8. The side of the door 2 is opened, thereby providing an entrance for the service technician. These members are formed from, e.g., a steel product and bent so as to assume an L-shaped cross-sectional profile.

[0020] The four pillar members 9 are fixed to respective corners of the cage top 1a by means of welding. A bracket 13 is welded to upper portions of the two pillar members 9 fastened to positions close to the door 2. An elongated hole into which a stepped screw 11 is to be inserted is formed in a position close to the end of each pillar member 9.

[0021] Female threads into which the stepped screws 11 are to be screwed are formed at respective end sections of each handrail member 7, and a hole, which permits insertion of a screw 12 and fastens the same, is formed at a corner section of each handrail member 7. Each handrail member 7 is inserted into a space between the pillar member 9 located close to the door 2 and a rear pillar member 9 (located in a position distant from the door 2) and pivotally joined to the pillar members 9 by means of the stepped screws 11 inserted into the respective elongated holes. A female thread is formed at each end of the fixing member 8. The fixing member 8 can be fastened to both handrail members 7 through use of the screws 12 inserted into the respective holes.

[0022] There will now be described procedures for tucking away the safety fence having the foregoing construction. As shown in Fig. 1a, at the time of maintenance and inspection, the fixing member 8 is fastened to the two handrail members 7 remaining upright, through use of the screws 12 for limiting pivotal movement of the handrail members 7. In this state, the fixing member 8 acts also as a handrail of a safety fence at the time of an operation, as do the handrail members 7. The service technician gets on the cage top 1a, by means of taking a space on the cage top 1a close to the door 2 as an entrance.

[0023] When having completed maintenance and inspection, the service technician removes the fixing member 8 fastened to the handrail members 7. Next, after having been slid upward along the profiles of the elongated holes of the pillar members 9, the handrail members 7 are folded down in the directions of arrowheads shown in Fig. 1b. Subsequently, the service technician gets off the cage top 1A and fastens the fixing member 8 to the brackets 13 of the pillar members 9.

[0024] Procedures for assembling the safety fence remaining in a normal state at the time of maintenance and inspection are the reverse of those for tucking away the safety fence.

[0025] As mentioned above, in normal times other than maintenance and inspection, the fixing member 8 is attached to the brackets 13 of the right and left pillar members 9 located close to the door 2 on the cage top 1a so as to hinder the service technician from getting on the cage top 1a. More specifically, the fixing member 8 is

fastened to the entrance of the safety fence, to thereby block entry of the service technician into work space. As a result, when initiating maintenance and inspection, the service technician inevitably removes the fixing member 8 provided under his/her very nose, thereby acquiring an opportunity to assemble the safety fence. Consequently, there can be obviated a chance of the service technician performing an operation while leaving the safety fence tucked away.

[0026] Fig. 2 is a perspective view showing an elevator cage according to a second embodiment of the invention. More specifically, Fig. 2a is a perspective view of the elevator cage of the second embodiment at the time of maintenance and inspection, and Fig. 2b is a perspective view showing the elevator cage of the second embodiment in normal times.

[0027] The second embodiment differs from the first embodiment primarily in terms of the configuration of the pillar members 9. As shown in Figs. 2a and 2b, a stopper 9a is provided in the middle of each pillar member 9. Each of the stoppers 9a is made by means of bending the base of a portion of the pillar member 9 to substantially a right angle. As shown in Fig. 2b, the stoppers 9a limit a rotational angle when the handrail members 7 are folded down through rotation.

[0028] As shown in Fig. 2a, the fixing member 8 is fastened to the handrail members 7 at the time of maintenance and inspection. As shown in Fig. 2b, in normal times the fixing member 8 is housed in and tucked away at a predetermined position on the cage top 1a.

[0029] Reference numeral 14 designates a band for bundling purpose which is a member for bundling the handrail members 7 after collapse. As a result, after having been collapsed, the handrail members 7 are fixed so as to block the entrance without fail.

[0030] As mentioned above, the handrail members 7 are collapsed so as to block the service technician from getting on the cage top 1a in normal times other than maintenance and inspection. In other words, the thus-collapsed handrail members 7 block entry of the service technician into work space. As a result, the service technician inevitably raises the handrail members 7 located under his/her very nose at the time of maintenance and inspection, thereby acquiring an opportunity to assemble the safety fence. Consequently, there can be obviated a chance of the service technician performing an operation while leaving the safety fence tucked away.

[0031] Fig. 3 is a perspective view showing an elevator cage according to a third embodiment of the invention. More specifically, Fig. 3a is a perspective view of the elevator cage of the third embodiment at the time of maintenance and inspection, and Fig. 3b is a perspective view showing the elevator cage of the third embodiment in normal times.

[0032] The third embodiment differs from the second embodiment primarily in terms of the configuration of the handrail members 7 and that of the pillar members 9. As shown in Figs. 3a and 3b, a member corresponding to

the stopper 9a shown in Fig. 2 is not provided in the middle of each pillar member 9. Therefore, when the handrail members 7 are rotated to fall down, and the rotation of the handrail members 7 comes to a halt while the top end of the handrail member 7 remains into contact with the cage top 1a. As shown in Fig. 3b, the thus-collapsed handrail members 7 block entry of the service technician into work space.

[0033] A stay 10 is welded to each handrail section 7 in substantially parallel therewith. As shown in Fig. 3b, when the handrail members 7 are collapsed, the stays 10 block generation of a scaffold for the service technician. More specifically, the handrail members 7, each having the stay 10, cover the cage top 1a, thereby blocking the work space above the cage top 1a.

[0034] As mentioned above, the handrail members 7 are collapsed so as to block entry of the service technician onto the cage top 1a in normal times other than maintenance and inspection, and the stays 10 are provided such that no scaffold is ensured for the service technician. The service technician can be reliably prevented from performing an operation on the cage top 1a while the handrail members 7 remain collapsed. Consequently, there can be obviated a chance of the service technician performing an operation while leaving the safety fence tucked away.

[0035] Fig. 4 is a perspective view showing an elevator cage according to a fourth embodiment of the invention. More specifically, Fig. 4a is a perspective view of the elevator cage of the fourth embodiment at the time of maintenance and inspection, and Fig. 4b is a perspective view showing the elevator cage of the fourth embodiment in normal times.

[0036] The fourth embodiment differs from the second embodiment primarily in terms of the configuration of the handrail members 7 and that of the pillar members 9. As shown in Figs. 4a and 4b, a member corresponding to the stopper 9a shown in Fig. 2 is not provided in the middle of each pillar member 9. Further, each handrail member 7 is provided so as to overlap the outside of the corresponding pillar members 9 and is joined pivotally to the pillar members 9.

[0037] More specifically, holes, which permit insertion of the stepped screws 11 and fasten the same, are formed in respective end sections of each handrail member 7. The pillar members 9 are soldered to respective corners of the cage top 1a. A female thread into which the stepped screw 11 is to be screwed is formed in the end section of each pillar member 9. The handrail members 7 are pivotally joined to the pillar members 9 by means of the stepped screws 11.

[0038] In relation to the safety fence having the foregoing construction, at the end of maintenance and inspection, the service technician removes the fixing member 8 fastened to the handrail members 7 in the state of maintenance and inspection shown in Fig. 4a. The fixing member is then housed at a predetermined position. Next, while lowering the handrail members 7 in the di-

rections of arrowheads shown in Fig. 4b, the service technician gets off the elevator cage 1.

[0039] In the fourth embodiment, no member corresponding to the stopper 9a shown in Fig. 2 is provided. As shown in Fig. 4b, when as the handrail members 7 are folded down, the top ends of the pillar members 7 come into contact with portions of interior walls of the respective handrail members 7. As a result, the handrails 7 do not rotate any further and remain stationary at these positions. So long as the geometries of the top ends of the pillar members 7 are made changeable, the rotation angles of the handrail members 7 can be set arbitrarily to a certain extent.

[0040] As mentioned previously, the handrail members 7 are collapsed so as to block entry of the service technician onto the cage top 1a in normal times other than maintenance and inspection. In short, the collapsed handrail members 7 block entry into work space. As a result, at the time of initiation of maintenance and inspection, the service technician inevitably raises the handrail members 7 provided under his/her very nose, thus acquiring an opportunity to assemble the safety fence. Consequently, there can be obviated a chance of the service technician performing an operation while leaving the safety fence tucked away.

Industrial Applicability

[0041] As mentioned above, in one aspect, the elevator cage according to the present invention has a fixing member removably attached to a safety fence to be assembled on a cage top, wherein the fixing member is fixed so as to block movement onto the cage top when the safety fence is folded down. As a result, at the time of maintenance and inspection, a service technician inevitably removes the fixing member to get on the cage top and assembles the safety fence through use of the fixing member. Hence, the elevator cage is useful as an elevator cage capable of preventing a service technician from falling down during maintenance and inspection operation.

[0042] In another aspect, the elevator cage according to the invention has a safety fence to be assembled on a cage top of an elevator cage, and the safety fence has pillar members and handrail members, wherein the handrail members are pivotally joined to the pillar members such that movement onto the cage is top is blocked when the handrail members are folded down. As a result, at the time of maintenance and inspection, the service technician inevitably removes the fixing member for getting on the cage top, thereby assembling the safety fence. Hence, the elevator cage is useful as an elevator cage capable of preventing a service technician from falling down during maintenance and inspection operation.

[0043] In another aspect, the elevator cage according to the invention has a stopper provided on each of the pillar members for limiting a rotation angle of fold-down handrail members. As a result, the handrail members are

folded down to arbitrary positions except at the time of maintenance and inspection, thereby thoroughly preventing the service technician from getting on the cage top. Moreover, the elevator cage is useful as an elevator cage capable of preventing a service technician from falling down during maintenance and inspection operation.

[0044] In another aspect, the elevator cage according to the invention is constructed such that fold-down handrail members cover a cage top when folded down. When the handrail members are folded down, no scaffold is ensured for the service technician. Therefore, the service technician initiates maintenance and inspection without forgetting to assemble a safety fence. Hence, the elevator cage is useful as an elevator cage capable of preventing a service technician from falling down during maintenance and inspection operation.

[0045] Further, in another aspect, the elevator system according to the invention has an elevator cage, wherein the cage has a member for hindering movement onto cage top when a safety fence provided on the cage top is folded down. There is alleviated a chance of a service technician forgetting to raise a safety fence at the initiation of maintenance and inspection. Hence, the elevator system is useful as an elevator system capable of preventing the service technician from falling down during maintenance and inspection operation.

Claims

1. An elevator cage (1) having a fold-down safety fence, which fence is provided on a cage top and enables movement onto the cage top from a side of a doorway (2), wherein the safety fence has a removably attachable fixing member (8) which fixes the safety fence when the safety fence is raised; and **characterized in that** the fixing member (8) is fixed in a position close to the doorway when the safety fence is folded down so as to block an entrance of the safety fence.
2. An elevator cage (1) having a fold-down safety fence, which fence is provided on a cage top and enables movement onto the cage top from a doorway (2), wherein the safety fence has pillar members (9) fixed on the top and handrail members (7) pivotally joined to the pillar members (9); and **characterized in that** the handrail members (7) are formed so as to block an entrance of the safety fence when folded down.
3. The elevator cage (1) according to claim 2, wherein the pillar members (9) have stoppers for limiting a rotational angle of the pivotable handrail member (7).
4. The elevator cage (1) according to claim 2 or 3,

wherein the handrail members (7) are formed so as to cover the cage top when folded down.

proche de l'embrasure lorsque la barrière de sécurité est repliée de façon à bloquer une entrée de la barrière de sécurité.

Patentansprüche

1. Aufzugskabine (1) mit einem herunterklappbaren Sicherheitszaun, wobei der Zaun auf einer Aufzugskabinenoberseite vorgesehen ist und eine Bewegung auf der Aufzugskabinenoberseite von einer Seite einer Tür (2) her ermöglicht, wobei der Sicherheitszaun ein lösbar anbringbares Befestigungselement (8) aufweist, das den Sicherheitszaun befestigt, wenn der Sicherheitszaun aufgestellt ist; und

dadurch gekennzeichnet, dass

das Befestigungselement (8) derart an einer Position nahe an der Tür befestigt wird, wenn der Sicherheitszaun heruntergeklappt ist, dass es den Eingang des Sicherheitszauns blockiert.

2. Aufzugskabine (1) mit einem herunterklappbaren Sicherheitszaun, wobei der Zaun auf einer Aufzugskabinenoberseite vorgesehen ist und die Bewegung auf der Aufzugskabinenoberseite von einer Seite einer Tür (2) her ermöglicht, wobei der Sicherheitszaun Säulenelemente (9), die auf der Oberseite befestigt sind, und Handlaufelemente (7), die schwenkbar mit den Säulenelementen (9) verbunden sind, aufweist; und

dadurch gekennzeichnet, dass

die Handlaufelemente (7) derart ausgebildet sind, dass sie einen Eingang des Sicherheitszauns blockieren, wenn sie heruntergeklappt sind.

3. Aufzugskabine (1) nach Anspruch 2, wobei die Säulenelemente (9) Stopper zum Begrenzen eines Drehwinkels der schwenkbaren Handlaufelemente (7) aufweisen.

4. Aufzugskabine (1) nach Anspruch 2 oder 3, wobei die Handlaufelemente (7) derart ausgebildet sind, dass sie die Aufzugskabinenoberseite bedecken, wenn sie heruntergeklappt sind.

5 2. Cage d'ascenseur (1) ayant une barrière de sécurité repliable, laquelle barrière est disposée sur un toit de cage et permet un mouvement sur le toit de cage à partir d'une embrasure (2), dans laquelle la barrière de sécurité a des éléments formant piliers (9) fixés sur le toit et des éléments formant rampe (7) articulés de manière pivotante aux éléments formant piliers (9) ; et

caractérisée en ce que

les éléments formant rampe (7) sont formés afin de bloquer une entrée de la barrière de sécurité quand elle est repliée.

3. Cage d'ascenseur (1) selon la revendication 2, dans laquelle les éléments formant piliers (9) ont des butées pour limiter un angle de rotation des éléments formant rampe pivotants (7).

4. Cage d'ascenseur (1) selon la revendication 2 ou 3, dans laquelle les éléments formant rampe (7) sont formés de façon à couvrir le toit de cage quand ils sont repliés.

Revendications

1. Cage d'ascenseur (1) ayant une barrière de sécurité repliable, laquelle barrière est disposée sur un toit de cage et permet un mouvement sur le toit de cage à partir d'un côté d'une embrasure (2), dans laquelle la barrière de sécurité a un élément de fixation (8) pouvant être attaché de façon amovible qui fixe la barrière de sécurité lorsque la barrière de sécurité est levée ; et

caractérisée en ce que

l'élément de fixation (8) est fixé dans une position

Fig. 1a

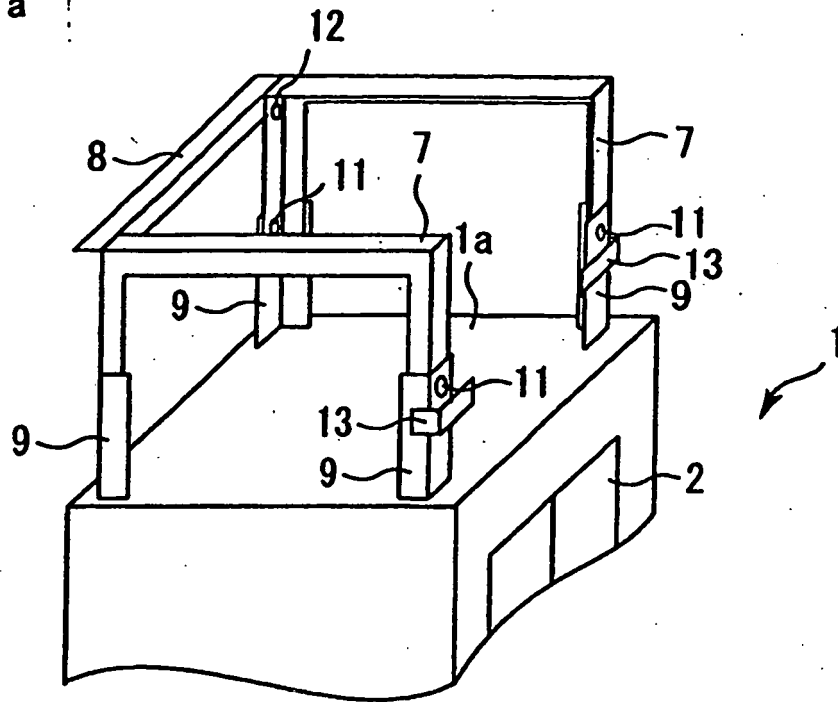

Fig. 1b

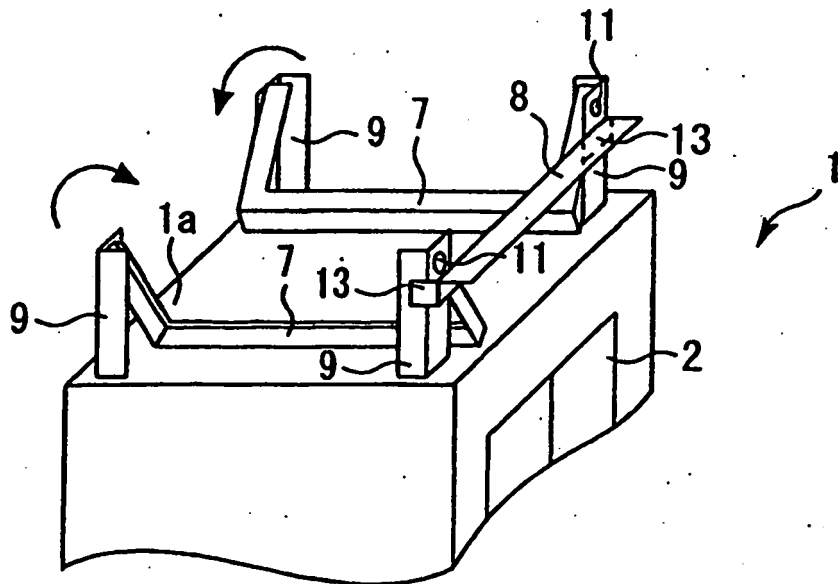

Fig. 2a

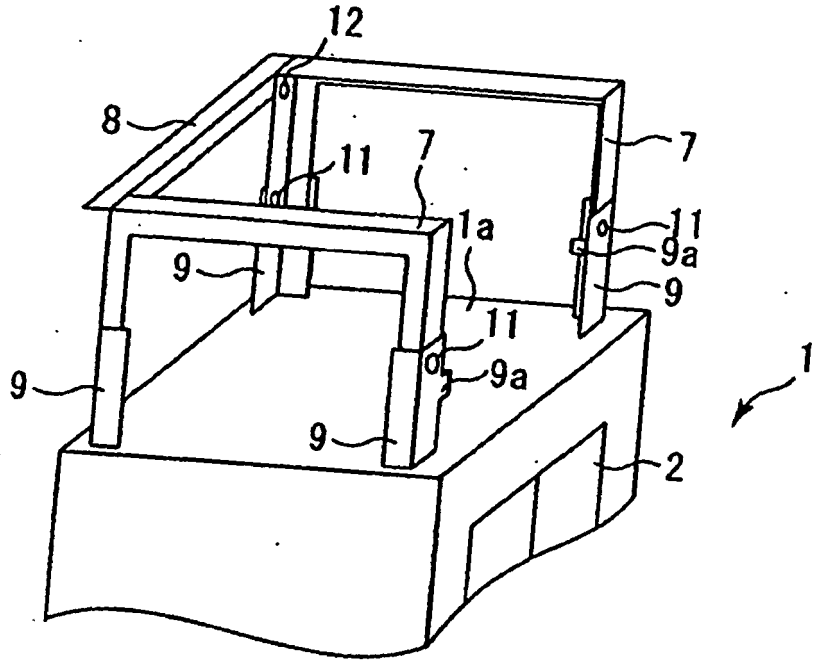

Fig. 2b

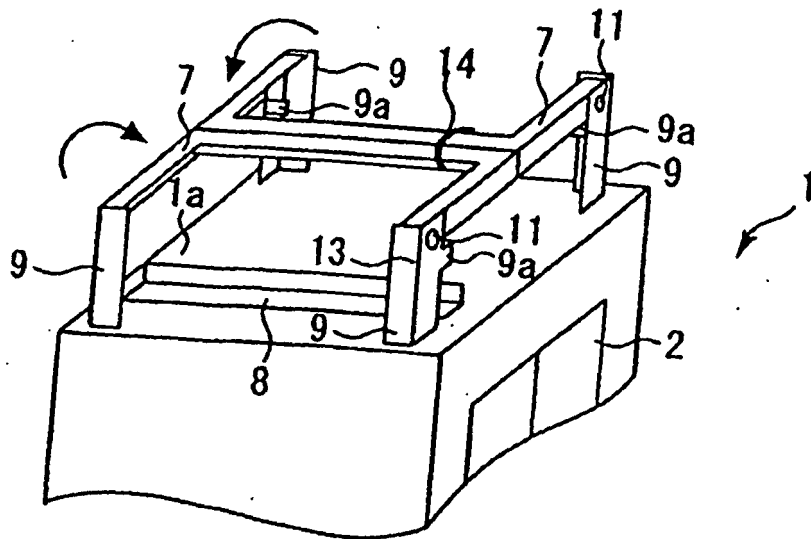

Fig. 3a

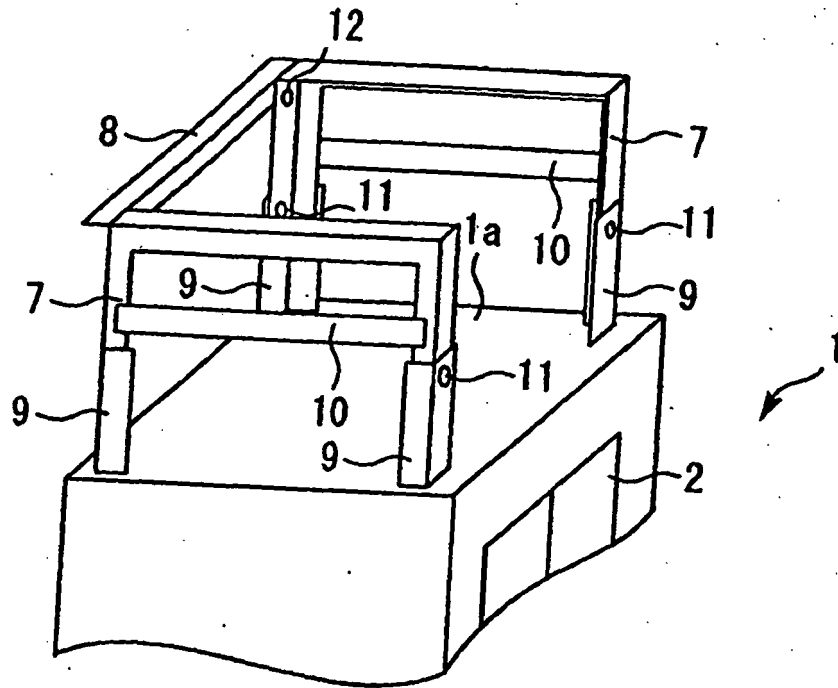

Fig. 3b

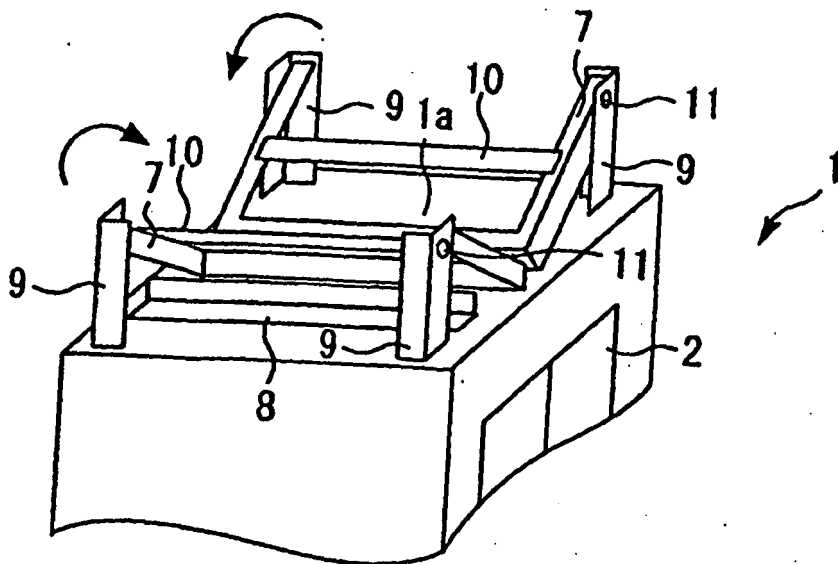

Fig. 4a

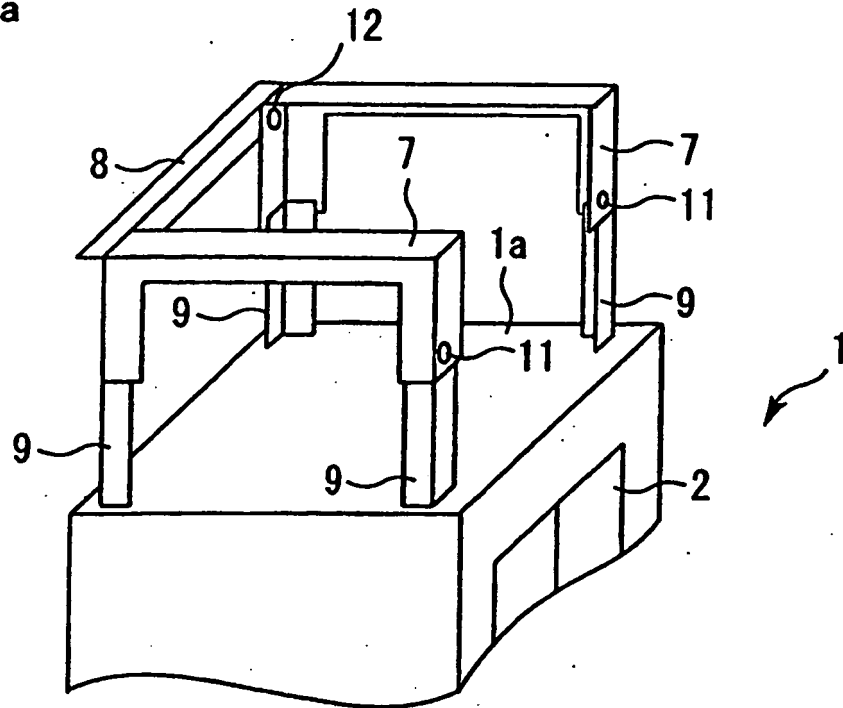

Fig. 4b

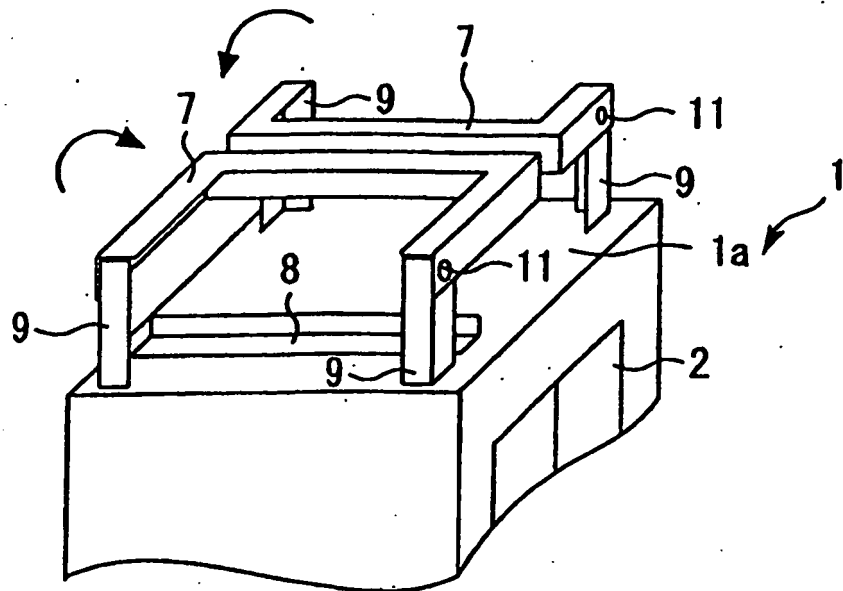

Fig. 5a

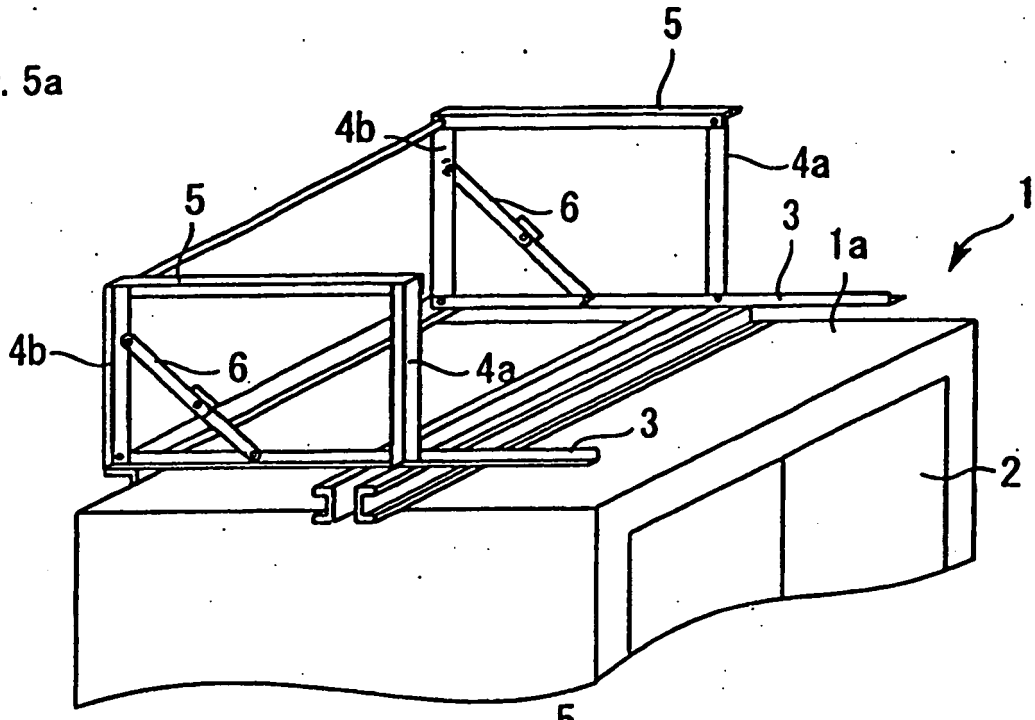

Fig. 5b

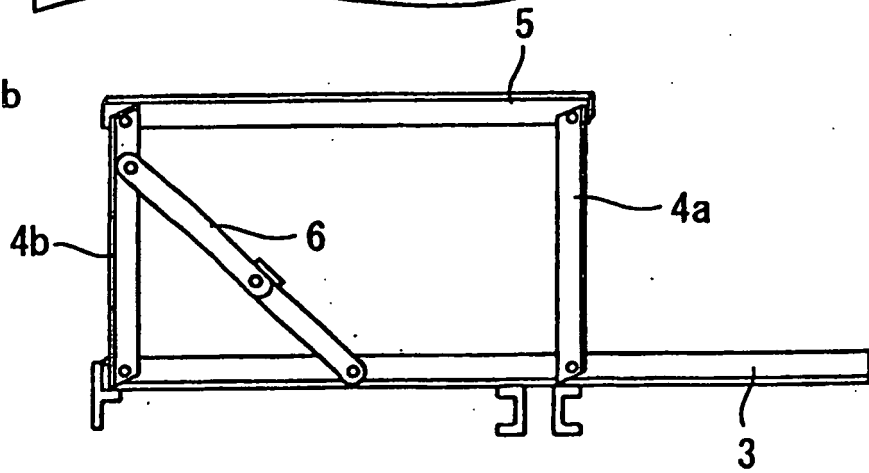
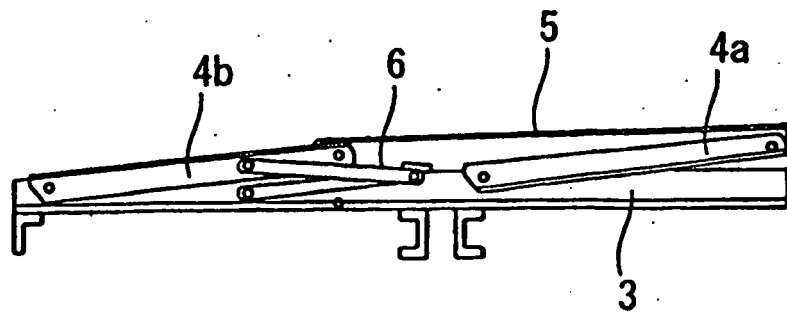

Fig. 5c



REFERENCES CITED IN THE DESCRIPTION

This list of references cited by the applicant is for the reader's convenience only. It does not form part of the European patent document. Even though great care has been taken in compiling the references, errors or omissions cannot be excluded and the EPO disclaims all liability in this regard.

Patent documents cited in the description

- EP 0985628 A [0002]