

T. J. TRAPP.
Improvement in Bag-Holders.

No. 130,547.

Patented Aug. 13, 1872.

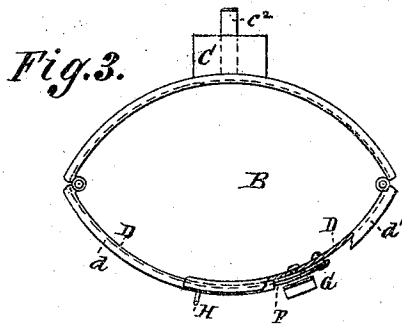
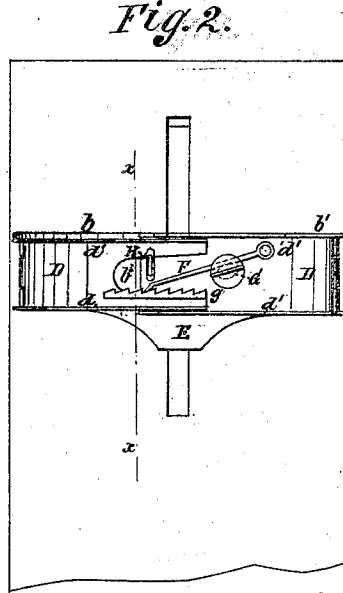
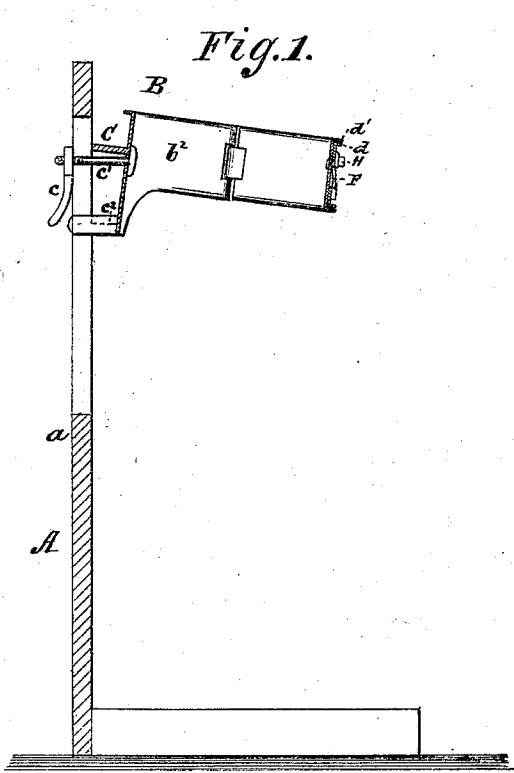

Witnesses:

G. Martin.

John Kemon

Inventor:

Thomas J. Trapp

PER

Allen T. B.

Attorneys.

UNITED STATES PATENT OFFICE.

THOMAS J. TRAPP, OF WILLIAMSPORT, PENNSYLVANIA.

IMPROVEMENT IN BAG-HOLDERS.

Specification forming part of Letters Patent No. 130,547, dated August 13, 1872.

Specification describing an Improved Bag-Holder, invented by THOMAS J. TRAPP, of Williamsport, in the county of Lycoming, and State of Pennsylvania.

The invention relates to improvements upon a bag-holder patented by me on the 4th of July 1871, and numbered 116,777. The invention consists in providing a bag-holder with a shank tapering on the rear side, so as to throw the mouth of bag on a decline toward the front, and with an auxiliary stem-guide; in providing the jointed arms with edge flanges, so that one arm may slide within the other, and with ratchet and pawl to hold them at different degrees of expansion; and in providing the pawl with a flanged holder that raises from and lets down the pawl into ratchet.

In the drawing, Figure 1 is a sectional and Fig. 2 a front elevation, showing my improvement. Fig. 3 is a detail top view of the bag-holder.

A represents the frame, described in the patent referred to, containing a platform operated by a treadle to shake the bag, and the slotted standard *a*, to which the bag-holder is attached. B is a bag-holder, with jointed and extensible arms *b b*¹ and rear plate *b*². C is that part of the bag-holder which abuts against the face of standard, and which may be a block or hollow shank, cast or otherwise attached to the rear thereof. This shank projects on top at a maximum extent from bag-holder, and lessens its distance therefrom gradually toward the lower end. This downward taper of the shank C gives a slight forward decline to the bag-holder, so that the mouth of the bag will be lower in front than on the opposite side. This very considerably facilitates the operation of pouring in the grain from a measure or other vessel. *c c*¹ are the clamp-screw and nut, by which the holder is fastened to the standard; and *c*² a guide-stem that works in slot of standard. The arms *b b*¹ and rear plate *b*² are turned up on each edge of the outside, so as to form a channel, D. This channel is narrower on one arm, *b*, than on the other, in order that the flanges *d d* of one arm may fit snugly within the flanges *d' d'* of the other arm. These two flanges thus conjointly keep the arms together, and at the same time form a guide to each, while the upper flange serves to hold the edge of bag when turned over it. The arm *b* is provided with a ratchet, E, near the lower part of a recess, *b*³, while the arm *b*¹ has a loosely-pivoted pawl, F, that

works in the ratchet and holds the mouth of bag stretched, whatever may be the width or size of bag. The arm *b*¹ is also provided with a pivoted plate, G, having two vertical flanges, *g g*, between which the pawl F is held and prevented from lateral movement, while by turning said plate G a quarter of a revolution the pawl may be lifted and held up from the ratchet. H is a latch, which holds the arms together.

The application is as follows: The screw *c*¹ and guide *c*² being inserted in slot of standard, the nut *c* is turned by its handle until the bag-holder is firmly attached to the standard. The bag is then put up through the inner part of holder, and its edges turned over the top flanges. The arms are now expanded until the mouth of the bag is stretched and held tight on the holder, while the pawl and ratchet maintain them at any degree of expansion that the bag will allow. On account of the taper on the rear side of shank C, the mouth of bag inclines forward toward the bagger, and allows the bag to be filled with ease and convenience. As soon as it has received the quantity of grain desired, the plate G is turned at a right angle to the pawl and lifts it from the ratchet, while the latch H is turned off so as to unclamp the arms. The bag is then taken readily from the holder.

Having thus described my invention, what I claim as new, and desire to secure by Letters Patent, is—

1. The rear-tapered shank C, combined with a bag-holder, as and for the purpose set forth.
2. The shank C, guide-stem *c*², and clamp-screw *c*¹, combined with a bag-holder, as and for the the purpose described.
3. A bag-holder, provided with hinged and channeled arms *b b*¹, that spread to any desired degree, to hold the bag thereto tightly, after being entered on the inside, as described.
4. The ratchet E and pawl F, combined with the hinged arms *b b*¹ of bag-holder, as and for the purpose set forth.
5. The combination, with pawl, of the pivoted plate G having flanges *g g*, between which the pawl is received, as and for the purpose set forth.

THOMAS J. TRAPP.

Witnesses:

THOS. D. D. OURAND,
SOLON C. KEMON.