

R. DIVEN.
Flat-Iron Heater.

No. 103,997.

Patented June 7, 1870.

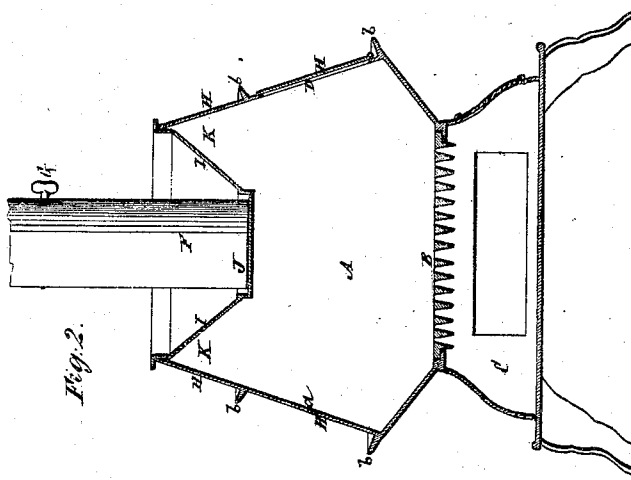

Fig. 2.

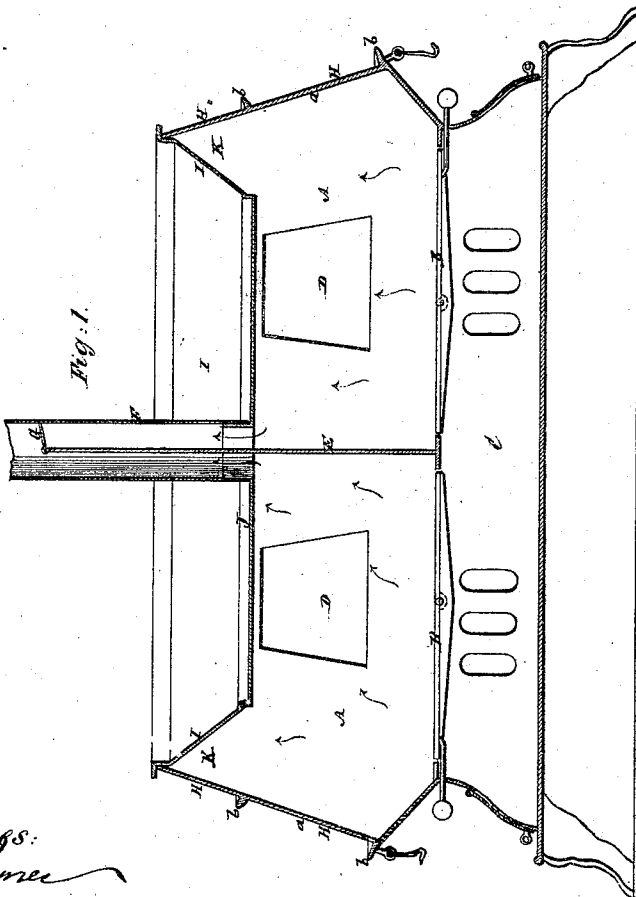

Fig. 1.

Witnesses:
Fred. Hayner
R. K. Rabeau

Robert Diven

United States Patent Office.

ROBERT DIVEN, OF NEW YORK, N. Y.

Letters Patent No. 103,997, dated June 7, 1870.

LAUNDRY-IRON HEATER.

The Schedule referred to in these Letters Patent and making part of the same.

To all whom it may concern:

Be it known that I, ROBERT DIVEN, of the city, county, and State of New York, have invented a new and useful Improvement in Laundry Iron-Heaters, of which the following is a full, clear, and exact description, reference being had to the accompanying drawing forming part of this specification, and in which—

Figures 1 and 2 represent sectional elevations, at right angles to each other, of a laundry-iron heater constructed in accordance with my improvement.

Similar letters of reference indicate corresponding parts.

My invention consists in a laundry-iron heater of peculiar construction, whereby an increased number of heating-surfaces is provided for the irons in a heater of given dimensions, fuel is economized, and the heater may be worked in a single or double capacity, as required, without duplication of the draught-pipe.

Referring to the accompanying drawing—

A A represent the fire-chambers or furnaces, and B B, the grates of a laundry-iron heater of a double construction.

C is the ash-pit, which may be common to both furnaces.

D D, the feed-openings for supplying the fuel, and which are fitted with doors, the ash-pit also being provided with a suitable door or doors for clearing out the ashes, and with air-inlets for keeping up the draught.

E is a division-plate, by which the heater is made to comprise two furnaces, separate and distinct from each other, but having a common smoke or draught-pipe, F, that is divided, for a portion of its height, by an extension of the plate E, and said pipe furnished with a damper, G, which, accordingly, as it is turned to occupy a vertical position in line with the plate E, or to a horizontal one, on opposite sides of said plate, serves to establish draught from both furnaces A A, or from either one, as may be required. Thus the whole heater may be worked by the two furnaces, or

either half of it only by a single furnace, which will be a great advantage in laundry-work.

The iron-holding and heating-surfaces I largely increase by not simply providing the sloping outside plates *a a* with ledges or rests *b b* for double rows of irons, the one above the other, forming iron-holding and heating-surfaces, H, but, also, by providing inner and upper additional similar surfaces, I, of a reverse slope to the outside surfaces H, and, in addition to these, utilizing, also, as resting-surfaces for irons, the top J of the heater.

These enlarged facilities are not only advantageous as regards the convenience afforded for heating a number of irons, and at different places about or around the heater, but also as regards the economy which results in point of fuel.

These advantages are due to the upward extension of the outside plates *a a*, depressed arrangement of the top J, and to the additional surfaces I, made to occupy reverse inclinations to the surfaces H, and so that an angular space, K, is established between such inner and outer iron-holding and heating-surfaces or plates, for the heated gases to accumulate in and heat both surfaces alike. It is not absolutely essential, to this feature of the invention, that the body of the heater should be separated by a division-plate, E, into separate furnaces, as shown in the drawing.

What is here claimed, and desired to be secured by Letters Patent, is—

1. The arrangement of the reversely inclined iron-heating surfaces H I and top J, relatively to each other, and the furnace or furnaces A of the heater, substantially as specified.

2. The combination of the division-plate E with the furnaces A A, the smoke-pipe F, and the damper G, essentially as shown and described.

ROBERT DIVEN.

Witnesses:

FRED. HAYNES,
E. E. RABEAU.