

(19) **DANMARK**



Patent- og
Varemærkestyrelsen

(10) **DK/EP 2884095 T3**

(12) **Oversættelse af
europæisk patentskrift**

-
- (51) Int.Cl.: **F 03 D 80/00 (2016.01)** **F 03 D 15/00 (2016.01)**
- (45) Oversættelsen bekendtgjort den: **2016-11-28**
- (80) Dato for Den Europæiske Patentmyndigheds bekendtgørelse om meddelelse af patentet: **2016-08-24**
- (86) Europæisk ansøgning nr.: **13196821.6**
- (86) Europæisk indleveringsdag: **2013-12-12**
- (87) Den europæiske ansøgnings publiceringsdag: **2015-06-17**
- (84) Designerede stater: **AL AT BE BG CH CY CZ DE DK EE ES FI FR GB GR HR HU IE IS IT LI LT LU LV MC MK MT NL NO PL PT RO RS SE SI SK SM TR**
- (73) Patenthaver: **Siemens Aktiengesellschaft, Wittelsbacherplatz 2, 80333 München, Tyskland**
- (72) Opfinder: **Jensen, Daniel Kai, Amaliegade 4, 3. th., 8700 Horsens, Danmark**
- (74) Fuldmægtig i Danmark: **Zacco Denmark A/S, Arne Jacobsens Allé 15, 2300 København S, Danmark**
- (54) Benævnelse: **Indstillet væskedæmper af en vindmølle**
- (56) Fremdragne publikationer:
EP-A1- 1 855 000
EP-A1- 2 157 314
EP-A1- 2 592 266
US-A1- 2003 147 753

DESCRIPTION

[0001] The invention relates to a liquid damper in a wind turbine.

[0002] A wind turbine comprises a tower, a nacelle, and a rotor. The rotor is rotatable connected to the nacelle of the wind turbine and the nacelle is rotatable connected to the tower.

[0003] The rotor comprises rotor blades and a rotor hub. The wind interacts with the rotor blades. This interaction leads to a rotation of the rotor hub. The rotational energy is transmitted to an electric generator and is there transferred into electrical energy.

[0004] EP 2157314 A1 describes a wind turbine comprising a direct driven generator having a stator arrangement, a rotor arrangement substantially arranged around the stator arrangement and a longitudinal center axis. The stator arrangement comprises a stator support structure, which stator support structure comprises at least one, substantially radial extending stator support element, wherein the stator element is attached to a substantially parallel to the center axis extending stationary shaft is substantially rigid in the radial direction and is at least partially in a certain extent flexible in the direction of the center axis of the generator.

[0005] The wind induces vibrations in the wind turbine. Vibrations reduce the lifetime of the components of the wind turbine and are therefore unwanted in the wind turbine.

[0006] The wind turbine comprises a passive damper system to reduce or eliminate vibrations in the wind turbine. The passive damper system can be a liquid damper, like a liquid sloshing type damper, also called tuned liquid damper, for example.

[0007] It is known to mount the tuned liquid dampers in the tower of the wind turbine or in the nacelle.

[0008] EP 1855000 A1 discloses a liquid sloshing damper which includes at least one hollow body with an internal space and a liquid contained in the internal space. A hollow bulge extends outward from the wall of the hollow body, the hollow bulge forming a bulge space which is part of the internal space.

[0009] This shows the disadvantage that the tanks of the tuned liquid dampers take up space in the tower of the nacelle of the wind turbine. Often this space is needed during installation or service by personnel, or the space is needed to install equipment or components in the wind turbine.

[0010] In addition the tuned liquid dampers are more effective when they are connected to a load transferring structure in the wind turbine. The connection is normally established by bolts, thus holes for the bolts are needed in the load transferring structure. This shows the disadvantage that the load transferring structure is weakened by the holes, thus the load transferring structure needs to be built with more material to provide the same strength as without bolt holes. This increases the weight of the wind turbine and thus the costs spent on the material and transportation of the wind turbine. In addition, these details increase the complexity of the casted structure and thus the overall costs of the wind turbine.

[0011] The aim of the invention is therefore to provide an improved concept of a tuned liquid damper of a wind turbine.

[0012] The object of the invention is achieved by the independent claim 1. Further features of the invention are disclosed in the dependent claims.

[0013] A damper system of a direct driven wind turbine is disclosed, whereby the wind turbine comprises a nacelle, a rotor hub and an electric generator. The electric generator comprises a rotor and a non-rotating part. The rotor hub is connected to the rotor of the electric generator. The non-rotating part of the generator is connected to the nacelle.

[0014] The wind turbine comprises a damper system to at least partially eliminate an unwanted movement of the wind turbine resulting from wind loads, whereby the damper system comprises a liquid damper. The damper system is arranged at a non-rotating part of the electric generator.

[0015] A direct driven wind turbine comprises a generator with a rotor and a stator. The rotor hub of the wind turbine, comprising the rotor blades, is connected directly to the rotor of the generator. The stator of the electric generator is a part of the non-rotating part of the generator, and is connected to the nacelle of the wind turbine.

[0016] The wind interacts with the rotor blades of the wind turbine and causes a rotation of the rotor hub of the wind turbine. The rotor hub of the wind turbine is connected to the rotor of the generator.

[0017] Thus; the rotation of the rotor hub is directly transferred to the electrical generator. In the electric generator, the rotation of the rotor is transformed into electrical energy.

[0018] While the wind interacts with the wind turbine, loads and vibrations are induced into the wind turbine. These loads and vibrations induced into the wind turbine lead to a vibration of the wind turbine. A vibration reduces the lifetime of the wind turbine especially when the eigenfrequency is reached.

[0019] Thus, a damper system is arranged within the wind turbine. The damper system comprises a liquid tank, thus, the damper system comprises a liquid damper.

[0020] The damper system is arranged at the non-rotating part of the electric generator. The electric generator of a direct driven wind turbine is quite large and shows a hollow space. The liquid damper is arranged within this hollow space..

[0021] Thus, the liquid damper does not take up space within the nacelle or the tower of the wind turbine.

[0022] The higher up in a wind turbine a damper system is placed, the more efficient, is the damping effect. The generator of the wind turbine is placed at the height of the nacelle. A damper system located in the non-rotating part of the generator is thus more efficient than a damper system in the tower of the wind turbine.

[0023] Thus, a damper system in the tower is more efficient than in the tower of the wind turbine. The rotor of the electric generator is arranged rotatable around a non-rotating part of the generator.

[0024] Thus, the generator is of the type of an outer rotor generator. Thus, the stator is arranged inside of the rotor of the generator. Thus, the support structure of the stator and the shaft are arranged radially inward of the stator.

[0025] Thus, the shaft, the support structure and the stator form the inner part of the generator. Thus, the whole inner part of the generator is the non-rotating part.

[0026] Thus, the damper system with the liquid tanks and the rack can easily be arranged and connected to the non-rotating part of the generator.

[0027] The shaft of the non-rotating part of the electrical generator is hollow and a damper system is arranged within the hollow shaft.

[0028] The electric generator of a direct driven wind turbine comprises a diameter of up to several meters. In addition, also the shaft of the direct driven generator has a diameter of more than one meter.

[0029] To save weight of the components of the wind turbine, the shaft of the electrical generator is hollow. Thus, the shaft of the electrical generator comprises a cavity and rack and the damper tanks are arranged within the cavity.

[0030] The axis of rotation of the rotor hub and the rotor of the electrical generator goes through the cavity within the hollow shaft of the generator.

[0031] Thus, the rack and the damper tanks, arranged in the cavity within the shaft, are arranged close to the axis of rotation of the electrical generator.

[0032] Thus, the vibrations that are induced into the wind turbine by the wind can easily be eliminated by the dampers without introducing an eccentric mass into the wind turbine.

[0033] In addition the damper is thus placed high up in the wind turbine. Thus the lever between the ground the wind turbine is placed on and the damper system is large and thus the damping effect is increased.

[0034] The damper system comprises a rack and at least two liquid tanks.

[0035] The damper system is a liquid damper and thus comprises a liquid tank. At least two liquid tanks are arranged to form the damper system.

[0036] The at least two liquid tanks are mounted to a rack. Thus, a rack is used to connect the liquid tanks together, and to the non-rotating part of their electric generator.

[0037] The rack comprises a magnet and the rack is connected to the non-rotating part of the generator by magnetic force.

[0038] At least one magnet is mounted to the rack of the liquid damper. The non-rotating part of the generator is made of metal, thus, the magnet can connect with the non-rotating part of the generator.

[0039] Thus, the rack is connected to the non-rotating part of the generator by magnetic force. Thus, no mechanical connection means are necessary.

[0040] Mechanical connection means would need a hole drilled into the non-rotating part of the generator to connect the rack with the non-rotating part of the generator. A hole in the non-rotating part of the generator would weaken the structure of the non-rotating part.

[0041] By connecting the rack by magnetic force to the non-rotating part of the generator, holes for mechanical connection means in the non-rotating part of the generator are avoided.

[0042] The rack is connected to the non-rotating part by magnetic force and not by mechanical connection means, thus, a weakening of the non-rotating part of the generator by holes is avoided.

[0043] The liquid tanks are cuboids, whereby the width is smaller than the length, and the height is smaller than the width.

[0044] Thus, the liquid tanks are flat cuboids. The rotor hub of the wind turbine and the rotor of the electric generator define a rotational axis of the wind turbine.

[0045] The wind interacts with the wind turbine mainly parallel to the rotational axis of the wind turbine during the operation of the wind turbine. Thus, loads and vibrations are induced into the wind turbine mainly parallel to the rotational axis of the wind turbine.

[0046] The width of the liquid tanks is smaller than the length. Thus, the liquid tanks comprises a longish shape. The long side of the liquid tanks is arranged mainly parallel to the rotational axis of the wind turbine.

[0047] The length of the liquid tanks is selected according to the frequency of the vibrations of the wind turbine that should be eliminated, and the properties of the liquid- that is capable to move inside the liquid tanks.

[0048] Thus, the form- of the liquid tank is selected to optimize the damping of the vibrations induced by the wind into the wind turbine.

[0049] The at least two liquid tanks are arranged in a stacked manner. The liquid tanks of the damper are arranged in a rack. They are arranged in a stacked manner, thus, they are arranged on top of each other.

[0050] As the height of the liquid tanks is smaller than the width and the length, the liquid tanks take up less area when they are stacked on top of each other. Thus, the use of the room within the wind turbine is optimized.

[0051] The non-rotating part of the generator comprises a stator and a shaft and the rack is arranged at the shaft.

[0052] An electric generator comprises a stator. The stator is mounted to a shaft.

[0053] The rack comprises the liquid tanks of the damper system and is connected to the shaft. The shaft of the electric generator supports the stator and is connected to the nacelle of the wind turbine.

[0054] The rack is connected to the shaft, thus, the shaft supports the rack and connects the rack to the nacelle of the wind turbine.

[0055] The shaft comprises a cavity and the rack is arranged within the cavity.

[0056] In a direct driven wind turbine, the generator is quite large, and comprises a diameter up to several meters. The stator of the electric generator is arranged in the outer part of the generator.

[0057] The stator is supported by a shaft. A support structure might be arranged between the stator and the shaft. The support structure supporting the stator is a part of the shaft of the electrical generator.

[0058] A cavity is formed between the stator of the electrical generator and the shaft. In the case of a direct driven wind turbine, the shaft might have a diameter bigger than one meter. Thus, also a cavity is formed within the shaft of the electrical generator in the case of a hollow shaft.

[0059] These cavities are not used otherwise and are empty. The rack comprises the liquid tanks of the damper system, and is connected to the shaft of the electrical generator. The rack with the damper system is arranged within one of the cavities of the generator.

[0060] Thus, the rack is arranged within the hollow shaft of the generator or within a cavity between the shaft and the stator of the generator.

[0061] Thus, the rack is arranged in a space within the wind turbine that is not used otherwise, and thus the rack does not take up space that is necessary for other installations.

[0062] The rack is mounted to a side wall of the non-rotating part of the generator.

[0063] The rack with the damper tanks is mounted to the side walls of the non-rotating part, for example magnetically. Thus the rack with the damper system is not taking up the space around the rotational axis of the electrical generator. Thus, the space around the rotational axis stays free for installation like cable turning equipment, hydraulic connections or equipment measuring the rotation of the wind turbine.

[0064] In addition, an aisle is kept free within the generator. Thus, service personnel can pass through the generator and can easily reach the rack and the damper system while passing through the generator along the aisle.

[0065] The invention is shown in more detail by the help of figures. The figures show a preferred configuration and do not limit the scope of the invention.

FIG 1 shows a wind turbine with a damper system.

FIG 2 shows a damper system of a direct driven wind turbine.

FIG 1 shows a wind turbine with a damper system.

[0066] FIG 1 shows a wind turbine with a damper system 1. The wind turbine comprises a nacelle 2 and a rotor hub 3. The rotor hub 3 is connected to the rotor 5 of the electrical generator 4. The rotor hub 3 is prepared to be equipped with rotor blades.

[0067] The electrical generator 4 comprises a rotor 5 and a stator 13. The stator 13 is supported by the support structure 6 that is connected to a shaft 14. The stator 13, the support structure 6 and a shaft 14 form the non-rotating part of the generator. The shaft 14 of the electrical generator 4 is connected to a support structure within the nacelle 2 of the wind turbine.

[0068] When the wind turbine is in operation, the wind interacts with the rotor blades and the rotor hub 3 rotates together with the rotor 5 or the electrical generator 4. The rotor 5 of the electrical generator rotates, in respect to the stator 13 of the electrical generator 4.

[0069] A cavity is formed within the non-rotating part 6 of the generator 4. One cavity is formed between the shaft 14 and the stator 13, and another cavity is formed within the hollow shaft 14.

[0070] A damper system 1 is arranged within the hollow shaft 14 of the electrical generator 4.

[0071] .During the operation of the wind turbine the wind induces loads and vibrations into the wind turbine through the rotor and the tower of the wind turbine. The vibrations are transferred from the rotor hub 3 and the rotor 5 of the electrical generator 4 to the shaft 14 and to the nacelle 2 -of the wind turbine. In addition the vibrations from the tower of the wind turbine are transferred over the support structure of the wind turbine to the shaft 14 of the wind turbine. The damper system 1 is prepared to eliminate the vibration induced into the wind turbine by the wind.

[0072] FIG 2 shows a damper system of a direct driven wind turbine.

[0073] FIG 2 shows a damper system 1 of direct driven wind turbine. The damper system 1 is arranged within the hollow shaft 14 of the non-rotating part 6 of the electrical generator.

[0074] The damper system comprises a rack 7 and at least two liquid tanks 8. The damper tanks 8 show a certain length 10, a certain width 12, and a certain height 11. The height 11 of the damper tank 8 is smaller than the width 12. The width 12 of the damper tank is smaller than the length tank 10 of 'the damper tank 8.

[0075] The damper tanks 8 are arranged in a stacked manner within the rack 7 of the damper system.

[0076] The rack 7 is connected to the side wall 16 of the hollow shaft 14 of the non-rotating part 6 of the electrical generator. The rack is connected to the side wall of the shaft by magnets 9.

[0077] The liquid tanks 8 are arranged along the side wall 16 of the shaft 14, mainly parallel to the axis of rotation of the electrical generator 4.

[0078] 'Besides of the damper system 1 enough free space is provided within the shaft 14 for service personnel to walk through the hollow shaft 14 of the electrical generator.

[0079] The illustration in the drawings is in schematic form. It is noted that in different figures, similar or identical elements are provided with the same reference signs.

[0080] Although the present invention has been described in detail with reference to the preferred embodiment, it is to be understood that the present invention is not limited by the disclosed examples, and that numerous additional modifications and variations could be made thereto by a person skilled in the art without departing from the scope of the invention.

[0081] It should be noted that the use of "a" or "an" throughout this application does not exclude a plurality, and "comprising" does not exclude other steps or elements. Also elements described in association with different embodiments may be combined. It should also be noted that reference signs in the claims should not be construed as limiting the scope of the claims.

REFERENCES CITED IN THE DESCRIPTION

This list of references cited by the applicant is for the reader's convenience only. It does not form part of the European patent document. Even though great care has been taken in compiling the references, errors or omissions cannot be excluded and the EPO disclaims all liability in this regard.

Patent documents cited in the description

- [EP2157314A1 \[0004\]](#)
- [EP1255000A1 \[0008\]](#)

Patentkrav

1. Dæmpersystem (1) af en direkte drevet vindmølle,
- hvor vindmøllen omfatter en nacelle (2), et rotornav (3) og en elektrisk generator (4),
5 - hvor den elektriske generator (4) omfatter en rotor (5) og en ikke-roterende del (6),
- hvor rotornavet (3) er forbundet med rotoren (5) af den elektriske generator (4),
10 - hvor den ikke-roterende del (6) af generatoren (4) er forbundet med nacellen (2),
- hvor vindmøllen omfatter et dæmpersystem (1) for i det mindste delvist at eliminere en uønsket bevægelse af vindmøllen, hvilket resulterer fra vindbelastninger,
15 - dæmpersystemet (1) er anbragt på den ikke-roterende del (6) af den elektriske generator (4),
- rotoren (5) af den elektriske generator (4) er anbragt roterbart om den ikke-roterende del (6) af generatoren (4),
- akslen (14) af den ikke-roterende del (6) af den elektriske generator (4) er
20 hul, **kendetegnet ved**, at dæmpersystemet (1) er anbragt inden i den hule aksel (14),
- hvor dæmpersystemet (1) omfatter en væskedæmper.
- 25 2. Dæmpersystem ifølge krav 1, **kendetegnet ved**, at dæmpersystemet omfatter et stativ (7) og mindst to væskebeholdere (8).
3. Dæmpersystem ifølge krav 2 **kendetegnet ved**, at stativet (7) omfatter en magnet (9), og at stativet (7) er forbundet med den ikke-roterende del (6) af

generatoren (4) ved magnetisk kraft.

- 5 4. Dæmpersystem ifølge et af kravene 2 eller 3, **kendetegnet ved**, at væskebeholderne (8) er kasser, hvor bredden (12) er mindre end længden (10), og højden (11) er mindre end bredden (12).
5. Dæmpersystem ifølge et af kravene 2 til 4, **kendetegnet ved**, at de i det mindste to væskebeholdere (8) er anbragt over hinanden.
- 10 6. Dæmpersystem ifølge et af kravene 2 til 5, **kendetegnet ved**, at den ikke-roterende del (6) af generatoren (4) omfatter en stator (13) og en aksel (14), og at stativet (7) er anbragt på akslen (14).
- 15 7. Dæmpersystem ifølge krav 6, **kendetegnet ved**, at akslen (14) omfatter et hulrum (15), og at stativet (7) er anbragt inden i hulrummet (15).
8. Dæmpersystem ifølge krav 1, **kendetegnet ved**, at stativet (7) er monteret på en sidevæg (16) af den ikke-roterende del (6) af generatoren (4).

DRAWINGS

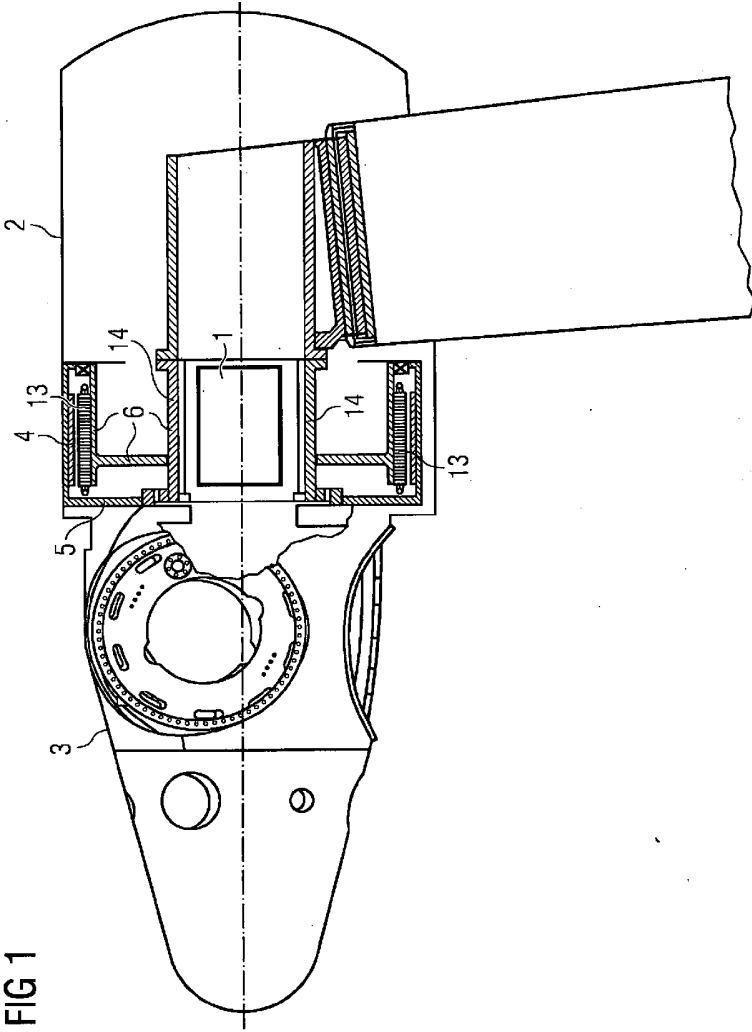

FIG 2

