



(11) **EP 1 885 018 B1**

(12) **EUROPEAN PATENT SPECIFICATION**

(45) Date of publication and mention of the grant of the patent:
02.09.2009 Bulletin 2009/36

(51) Int Cl.:
H01P 7/06 (2006.01) H01P 1/205 (2006.01)

(21) Application number: **06015381.4**

(22) Date of filing: **24.07.2006**

(54) **Tunable bandpass filter**

Abstimmbar Bandpassfilter

Filtre bande-passante accordable

(84) Designated Contracting States:
DE FR GB

(43) Date of publication of application:
06.02.2008 Bulletin 2008/06

(73) Proprietor: **Panasonic Corporation**
Kadoma-shi
Osaka 571-8501 (JP)

(72) Inventors:
• **Höft, Michael**
21271 Asendorf (DE)

• **Bartz, Olaf**
21365 Adendorf (DE)

(74) Representative: **UEXKÜLL & STOLBERG**
Patentanwälte
Beselerstrasse 4
22607 Hamburg (DE)

(56) References cited:
US-A- 3 693 115 US-A- 3 838 308
US-A- 5 977 849 US-A1- 2005 040 916

EP 1 885 018 B1

Note: Within nine months of the publication of the mention of the grant of the European patent in the European Patent Bulletin, any person may give notice to the European Patent Office of opposition to that patent, in accordance with the Implementing Regulations. Notice of opposition shall not be deemed to have been filed until the opposition fee has been paid. (Art. 99(1) European Patent Convention).

Description

[0001] The present invention relates to tunable band-pass filter, comprising a plurality of resonator cavities, each resonator cavity being equipped with a movable frequency tuning element extending into the cavity, and a control mechanism having a movable control element, wherein the tuning elements and the control element are arranged such that an adjusting movement of the movable control element causes the tuning elements to be simultaneously displaced with respect to the resonator cavities in dependence of the adjusting movement of the control element in order to adjust the centre frequencies of the resonator cavities.

[0002] Such tunable bandpass filter is for example known from US 2005/0212623. In each resonator cavity a dielectric tuning element is located, which is guided for linear movement along the inner surface of the lid of the cavity resonator. The tuning element is connected to a control element located at the outer surface of the lid wall by a pin extending through an elongated slot in the lid wall. The control element is formed by a rod extending along the series of resonator cavities in a first direction. This rod carries a dielectric tuning element in each of the resonator cavities in the series of resonators, and by displacement of the rod along the first direction, a simultaneous displacement of the dielectric tuning element in the resonator cavities may be performed to allow a desired adjustment of the centre frequencies. However, this simultaneous adjustment of the frequency tuning elements does not allow a flexible design since the dielectric tuning elements are mechanically linked to each other, and therefore only a uniform displacement of all frequency tuning elements along the series of resonators is possible. Alternatively, it is suggested that individual adjustment of the respective frequency tuning elements may be achieved by providing each frequency tuning element with its own actuator which may be individually controlled. However, to provide an individual actuator for controlled displacement for each of the resonator cavities is a rather elaborate and complex approach which has disadvantages regarding manufacturing costs, reliable long-term operational safety and many other aspects, as for example the relative calibration of the actuators with respect to each other.

[0003] US 2006/0038640 A1 describes a cavity resonator (also for use in multiple resonator assemblies such as combline resonators) having an inner conductor with a movable end cap. The end cap is mounted on a central rod and is separated from the inner surface of the lid by a dielectric disc. The distance between lid surface and the end cap determines the capacitance of the capacitor formed by lid surface, dielectric disc and end cap. This capacitance in turn influences the resonator frequency. To adjust the position of the end cap an electromagnet is provided which drives the rod carrying the end cap against a biasing force to a desired position. Again, provision of an individual actuator (an electromagnetic or

solenoid actuator in this case) for each resonator is an elaborate and complex approach.

[0004] Software-defined radio (SDR) is a rapidly evolving technology that is receiving widespread interest in the telecommunication industry. Over the last few years, analogue radio systems are being replaced by digital radio system for various radio applications in military, civilian and commercial spaces. In addition to this, programmable hardware modules are increasingly being used in digital radio systems. The aims of SDR are to define radio functions by software, and to configure a common hardware platform for a specific air interface by downloading software during operation or as part of the production cycle. To enable users to install such technology, tunable bandpass filters are needed. These filters have to be multi-standard filters and must be tunable over wide range.

[0005] US-A-3,838,308 describes a multi-cavity microwave device comprising the features of the preamble of claim 1. The device described is a multi-cavity klystron which uses an velocity modulated electron beam to amplify a microwave signal. Each cavity is provided with a frequency tuning element to tune the resonance frequency of each cavity. Each tuning element has a variable position extending into the cavity and projecting therefrom with a cam follower which abuts against a cam surface of a control element. By movement of the control element the tuning elements of all cavities are simultaneously adjusted by moving the control element with its cam surface along the cam followers of the tuning elements. In a klystron there are no coupling openings between cavity resonators having movable coupling tuning elements therein.

[0006] It is an object of the present invention to provide a tunable bandpass filter including a series of resonator cavities with coupling openings and coupling tuning elements therein which allows flexible adjustment of the coupling tuning elements of the resonators.

[0007] This object is achieved by a tunable bandpass filter having the features of claim 1.

[0008] The outer ends of the cam followers of the frequency tuning elements are in sliding contact with the cam surface of the control element. This sliding contact may be maintained either by gravitational force, in which case the cam followers must be vertically oriented and located in the bottom wall of the resonator cavities, or preferably by a biasing force, for example provided by springs which bias the cam followers to their maximally extended position to the outside.

[0009] Each cam follower may be moved to vary the positioning of the associated frequency tuning element inside of the cavity and thus to vary the centre resonance frequency of the resonator. The cam follower may for example be a pin which extends through the cavity wall and which carries a dielectric frequency tuning element located inside the cavity. By raising or lowering the cam follower, the dielectric frequency tuning element is then raised or lowered inside the resonator cavity. Alternatively, the cam follower may act on a flexible part of the res-

onator wall that may be flexed when the cam follower exerts a force on the flexible wall portion.

[0010] The positioning of the cam followers is determined by the cam surface against which their outer ends abut. The cam surface has a predetermined contour $z(x)$, wherein z denotes the height of the cam surface (perpendicular to the a first direction x) as a function of the position x along the first direction. A predetermined contour of the cam surface determines the pattern in which the cam followers and thus the frequency tuning elements are displaced when the control element is moved by the drive. If, for example, the contour comprises a series of ramps with the same slope, a uniform displacement of the frequency tuning elements would be achieved. However, by providing control elements with cam surfaces that have different slopes and/or shapes along the contour, a predetermined pattern of frequency adjustments of the resonators may in principle be accomplished.

[0011] The filter may for example comprise resonator cavities arranged in row along a first direction and the control element may be movable in the same direction. However, other arrangements of the resonator cavities and the direction of movement of the control element may also be realised as will be illustrated in the description below.

[0012] In a particularly preferred embodiment, the control element is formed by a plate having a three-dimensional cam surface, i.e. the contour $z(x)$ is a function of the location y (position on the plate in the direction perpendicular to the first direction x): $z(x, y)$. In this manner, for a given position y_i a predetermined contour $z(x, y_i)$ is provided. Preferably, $z(x, y)$ is a continuous function of y which allows to continuously vary $z(x, y)$ when varying y and thus to provide a continuous manifold of contours of the came surface along the first direction. In this embodiment a second drive is provided which allows the control element to be positioned at a desired y so that depending on the chosen y a predetermined contour $z(x, y)$ may be chosen.

[0013] According to the invention, the cavity resonators have coupling openings between adjacent cavity resonators and have movable coupling elements extending into the coupling openings. The coupling elements are displaceable likewise comprise cam followers which are movable in the same manner as the cam followers of the frequency tuning elements. Also the cam followers of the coupling tuning elements are arranged such that their outer ends are in sliding contact with the cam surface so that the positioning of the cam surface determines, in addition to the positioning of the frequency tuning elements, the positioning of the coupling tuning elements. In this embodiment, if it is again used in connection with a two-dimensional cam surface, predetermined variations of the couplings and the centre frequencies can be achieved by moving the control element to a particular position y such that a desired contour $z(x, y)$ is selected in which centre frequencies and coupling strength of the

resonator cavities are varied according to a desired relationship determined by $z(x, y)$.

[0014] The invention will be described in connection with embodiments shown in the figures, in which:

Fig. 1 shows a cross-sectional view of two coaxial resonators;

Fig. 2 shows a schematical top view of the resonators of Fig. 1;

Fig. 3 shows a cross-sectional view of a further embodiment of a bandpass filter;

Fig. 4 shows a schematical top view of the filter of Fig. 3;

Fig. 5 shows a perspective view of a control element that may be used in connection with the filter of Figures 3 and 4;

Fig. 6 shows a cross-sectional view of a further arrangement of resonators;

Fig. 7 shows a schematical top view of the resonator arrangement of Fig. 6;

Fig. 8 shows a perspective view of a control element that may be used in connection with the resonator arrangement of Figures 6 and 7;

Fig. 9 shows the centre frequency of a resonator as a function of the intruding length t_f of the frequency tuning element into the cavity;

Fig. 10 shows a graph of the transmission S_{21} and the return loss S_{11} for an exemplary bandpass filter having five resonator cavities for three frequency tuning adjustments;

Fig. 11 shows a graph of the transmission S_{21} and the return loss S_{11} for an exemplary bandpass filter having five resonator cavities for three frequency tuning and coupling tuning adjustments;

Fig. 12 shows the variation of a coupling factor, in this example between first and second resonator, which is suitable to keep the bandwidth constant when the centre frequency of the bandpass filter is tuned through the frequency indicated on the x axis;

Fig. 13 shows the dependence of the coupling between two adjacent resonators on the adjustment t_k (intruding length) of the coupling tuning element for three different settings of the intruding length t_f of frequency tuning elements of the resonators;

Fig. 14 shows a single cavity resonator which may

be used in a bandpass filter according to the invention;

Fig. 15 shows a single resonator cavity with an alternative embodiment of a cam follower and a frequency tuning element.

[0015] In Figure 1 two coaxial resonators having resonator cavities 2 are shown; of course, in general a bandpass filter may have any number of resonators. As a general remark, it should also be noted that for means for coupling electromagnetic energy to the filter and means for extracting it have been omitted in the drawing in order to simplify the graphical presentation.

[0016] Frequency tuning elements 10 extend in the resonator cavities 2 and are carried by cam followers 12 which project to the outside of the cavities. The cam followers 12 are guided for linear movement further into and out of the resonator cavities. The cam followers 12 are biased by springs 16 to a maximally extended position (only one spring is shown at one of the frequency tuning elements, springs at the other tuning elements, also in the other Figures have been omitted to simplify the graphical illustration).

[0017] Figs. 3 and 4 show an alternative arrangement of five resonator cavities forming a bandpass filter. As can be seen from Fig. 4, the resonators are not arranged in a row but form a V-shape.

[0018] Outside of the resonator cavities 2 a movable control element 20 is guided for linear movement along a first direction which may be designated as x. The outer ends of the cam followers 12 are in sliding contact with the cam surface 22 of the control element 20. The contour $z(x)$ of the cam surface is shaped in a predetermined manner such that by movement of the control element 20 the individual cam followers 12 and frequency tuning elements 10 are displaced in a predetermined manner given by the contour of the cam surface. For controlled movement of the control element 20 a drive 24 (Fig. 3), for example a step motor, is provided.

[0019] There are furthermore coupling tuning elements 30 which extend into openings between adjacent resonator cavities 2. The coupling tuning elements 30 are mounted and guided in a similar manner as the frequency tuning elements. The outer ends of the coupling tuning elements 30 are likewise formed as cam followers 32 arranged to be in sliding contact with the cam surface 22 of the control element 20. In this manner the positioning of the coupling tuning elements 30 may be varied in a predetermined way together with the adjustment of the centre frequencies of the resonators by the frequency tuning elements 20. Thus, in this arrangement, it is possible to vary the centre frequencies of the individual resonators as well as the coupling of the individual resonators. Thus, it is possible to vary the centre frequency of the bandpass filter as well as its bandwidth over a wide range.

[0020] In the example of Fig. 5 the control element has

a cam surface with nine ramps, wherein five ramps are associated with the five cam followers 12 of the five frequency tuning elements of the filter of Figures 3 and 4, and four ramps are associated with the cam followers 32 of the coupling tuning elements of the filter. By moving the control element 20 to an adjusted position each ramp is sliding along the associated cam follower 12, 32, and thus the vertical position (in the view of Fig. 3) of each cam follower 12, 32 is changed so that a predetermined positioning may be adjusted by moving the control element 20 to the desired position. In the embodiment shown in Figures 3 to 5 all cam followers are moved in the same sense when the control element is moved, i.e. if the frequency tuning elements 10 are shifted further inside into the resonator cavities, the coupling tuning elements 30 are likewise shifted further into the coupling opening.

[0021] An alternative arrangement is shown in Figures 6 to 8. Whereas the arrangement of the resonator cavities, frequency tuning elements 10, coupling tuning elements 30 and the cam followers 12, 32 is similar to the arrangement of Figures 3 and 4, control element 20, as best shown in Fig. 8, has an alternative arrangement. Here the cam surface has a varying contour along two dimensions x and y. This allows, for example, that the cam followers 12 of the frequency tuning elements 10 are sliding on cam surface portions which vary along the direction x, whereas the cam followers of the coupling tuning elements 32 are sliding on ramps oriented in the y direction. This allows, by independently adjusting the position in x and y, to adjust the centre frequencies of the resonators independently of the coupling tuning.

[0022] Fig. 9 shows how the centre frequency of a single resonator of the type as shown in Fig. 1 is varying when the depth at which the frequency tuning element is intruding into the cavity is varied, this depth being designated as t_f . At $t_f = -1$ mm the frequency tuning element is still outside of the resonator cavity, at a depth $t_f = 0,0$ mm the top surface of the frequency tuning element is flush with the inside wall of the resonator cavity. The variation of the centre frequency of the resonator is shown for three different cavity dimension, namely three different heights of the cavity h_c .

[0023] In Fig. 10 the behaviour of an exemplary bandpass filter comprising five resonators is shown. Here the return loss S11 is shown in dashed lines and the transmission S21 in full lines. At a first adjustment of the filter the bandpass filter has a centre frequency of about 1400 MHz. In a second adjusted state the centre frequencies of the resonators are increased such that the centre frequency of the filter is about 2000 MHz. In a third adjustment the centre frequency of the filter is adjusted to 2600 MHz. This increase of the centre frequency is achieved by moving the frequency tuning elements to lower intrusion lengths into the cavities, i.e. by letting the cam followers 12 slide down the cam surface 22, for example by moving the control elements 20 of Figure 3 to the right hand direction. As can be seen from Fig. 10 the bandwidth of the filter is increasing with increasing centre fre-

quencies. More precisely, the bandwidth of the filter is proportional to the centre frequency.

[0024] Fig. 13 shows that a variation of the centre frequency also leads to a variation in the coupling of resonators. As an example, Fig. 13 shows the coupling factor k (in units of 10^{-3}) of adjacent first and second cavity resonators as a function of the coupling tuning adjustment length t_k , for three different values of the intruding length t_f of the frequency tuning elements into the resonators cavities. As can be seen, with decreasing intruding length t_f and thus increasing centre frequency of the resonators, their coupling k is also increasing which contributes to the increasing bandwidth discussed above.

[0025] It may be desired to vary the centre frequency of the filter independently of the bandwidth, for example to vary the centre frequency while maintaining the bandwidth constant. This may be achieved when the coupling between adjacent resonators is lowered with increasing centre frequency.

[0026] In Fig. 12 a coupling between the first and second resonator of the exemplary five resonators of the filter is shown as decreasing with increasing centre frequency. By this decreasing coupling as illustrated it is accomplished to maintain the bandwidth of the filter constant with increasing centre frequency. This decreasing coupling may be achieved by displacing the coupling elements in a manner so that the coupling reduction as shown in Fig. 12 is achieved. The shape of the cam surface portions effective for the cam followers 32 of the coupling tuning elements 30 may be chosen in relation to the cam surface portions effective for the cam followers 12 of the frequency tuning elements 12 such that the bandwidth is maintained constant when the centre frequency of the band pass is adjusted. With such a coupling reduction it is possible to tune the bandpass centre frequency over a wide range while maintaining the bandwidth constant, as may be seen from Fig. 11 which shows the filter response for three centre frequency adjustments, with a bandwidth which is maintained constant.

[0027] In Fig. 14 a further schematical view of a single resonator which may be used in a filter according to the invention is shown. This resonator is shown to be equipped with a tuning screw 40. This tuning screw 40 may be useful in addition to the possible adjustment by way of the frequency tuning elements in order to allow to compensate for manufacturing tolerances in large scale production of filters. Thus, after manufacturing an initial fine-tuning may be accomplished whereafter the tuning may be performed using the cam surface, cam followers and tuning elements.

[0028] Fig. 15 shows an alternative arrangement of a cam follower 12 and a frequency tuning element 20. In this example the cam follower 12 does not extend into the resonator cavity but only up to a flexible wall portion of the resonator cavity 2. By moving the flexible wall portion which forms the frequency tuning element 10', the centre frequency of the resonator 2 is varied. The cam follower 12 abuts against a cam surface 22 of a control

element 20, and the position of the cam follower 12 may be adjusted by moving the control element 20 to a desired position. Of course, Fig. 15 shows only a partial view of a single resonator whereas the complete filter has more resonators and more tuning elements.

[0029] In the above described embodiments frequency and coupling tuning utilising the cam control mechanism of the present invention has been described. It is evident that other tuning elements may be controlled and adjusted in the same manner for, example cross-coupling tuning element, tuning elements for coupling electromagnetic energy to the filter (input) or for extracting electromagnetic energy from the filter (output), etc.. It is noted that in general the input and output side of the filter is interchangeable depending on the intended operation.

Claims

1. Tunable bandpass filter, comprising a plurality of resonator cavities (2), each resonator cavity being equipped with a movable frequency tuning element (10) extending at least partially in the cavity (2), and a control mechanism having a movable control element (20), wherein the frequency tuning elements (10) and the control element (20) are arranged such that an adjusting movement of the movable control element (20) causes the tuning elements (10) to be simultaneously displaced with respect to the resonator cavities (2) in dependence of the adjusting movement of the control element (20) in order to adjust the centre frequencies of the resonator cavities (2), wherein each frequency tuning element (10) comprises a cam follower (12) which is projecting from a wall of the respective resonator cavity (2) to the outside and which is guided for shifting movement therein to allow to adjust the position of frequency tuning element (10) by sliding the cam follower (12) further inside or outside with respect to the resonator cavity wall; the control element (20) comprises a cam surface (22) with a predetermined contour, the control element (20) and the cam followers (12) being arranged with respect to each other such that the cam surface is in sliding contact with an outer end of each of the cam followers (12), wherein the control element (20) is mounted for linear movement along a first direction to vary the position of the cam surface with respect to the cam followers (12), and a drive (24) is provided to adjust the position of the control element (20) along the first direction to a desired adjusted position so that each of the cam followers (12) and thereby its associated frequency tuning element (10) is adjusted as determined by the contour of the cam surface (22),
characterised in that
the cavity resonators (2) are coupled by coupling openings between adjacent cavity resonators (2),

- and wherein movable coupling tuning elements (30) extend into the coupling openings, wherein the coupling tuning elements are formed with cam followers (32) which are projecting to the outside of the cavities (2) and which are displaceable in the same manner as the cam followers (12) of the frequency tuning elements (10), and wherein the control element (20) and cam followers (32) of the coupling tuning elements (30) are arranged such that the outer ends of the cam followers (32) are in sliding contact with the cam surface (22) so that the positioning of the cam surface (22) determines in addition to the positioning of the frequency tuning elements (10) the positioning of the coupling tuning elements (30).
2. Tunable bandpass filter according to claim 1, wherein the resonator cavities (2) are arranged serially along the first direction.
 3. Tunable bandpass filter according to any of the preceding claims, wherein the cam follower (12) comprises a pin which has a tapered outer end tip and carries at its inner end a dielectric frequency tuning element (10).
 4. Tunable bandpass filter according to any of claims 1 or 2, wherein the cam follower (12) comprises a pin with a tapered outer end tip which at its inner end abuts against a flexible wall portion (10') of the resonator cavity (2) which forms the displaceable frequency tuning element.
 5. Tunable bandpass filter according to any of the preceding claims, wherein the cam surface (22) of the control element (20) has a contour comprising a series of continuously rising portions followed by falling portions.
 6. Tunable bandpass filter according to any of the preceding claims, wherein the drive (24) comprises a step motor.
 7. Tunable bandpass filter according to any of the preceding claims, wherein the control element (20) is mounted for movement along a second direction, different from the first direction, and wherein the contour of the cam surface along the first direction ($z(x)$) is varying along the second direction (y) of the control element (20).
 8. Tunable bandpass filter according to claim 5, wherein the control element (20) is a plate having a three-dimensional cam surface which defines a projection height z depending on the relative position x , y on the plate, wherein $z(x, y)$ defines the contour of the cam surface (22) along the first direction x at a position y along the further direction.
 9. Tunable bandpass filter according to any of the preceding claims, wherein a cross-coupling path is provided between two of the cavity resonators, and wherein a movable cross-coupling tuning element is provided which extends in the cross-coupling path, wherein the cross-coupling tuning element comprises cam follower which is projecting to the outside and which is displaceable in the same manner as the cam followers of the frequency tuning elements, and wherein the control element and cam follower of the cross-coupling tuning element are arranged such that the outer end of the cam follower is in sliding contact with the cam surface so that the positioning of the cam surface determines in addition to the positioning of the frequency tuning elements the positioning of the cross-coupling tuning element.
 10. Tunable bandpass filter according to any of the preceding claims, wherein a path for inputting electromagnetic energy into the bandpass filter is provided with a movable input tuning element which extends in the input path, wherein the input tuning element comprises cam follower which is projecting to the outside and which is displaceable in the same manner as the cam followers of the frequency tuning elements, and wherein the control element and cam follower of the input tuning element are arranged such that the outer end of the cam follower is in sliding contact with the cam surface so that the positioning of the cam surface determines in addition to the positioning of the frequency tuning elements the positioning of the input tuning element.
 11. Tunable bandpass filter according to any of the preceding claims, wherein an output path for extracting electromagnetic energy from the bandpass filter is provided with a movable output tuning element which extends in the output path, wherein the output tuning element comprises cam follower which is projecting to the outside and which is displaceable in the same manner as the cam followers of the frequency tuning elements, and wherein the control element and cam follower of the output tuning element are arranged such that the outer end of the cam follower is in sliding contact with the cam surface so that the positioning of the cam surface determines in addition to the positioning of the frequency tuning elements the positioning of the output tuning element.

Patentansprüche

1. Abstimmbarer Bandpassfilter mit einer Mehrzahl von Hohlraumresonatoren (2), wobei jeder Hohlraumresonator mit einem beweglichen Frequenzabstimmelement (10) ausgestattet ist, das sich wenigstens teilweise in den Hohlraum (2) hinein erstreckt, und mit einem Steuermechanismus mit einem bewegli-

chen Steuerelement (20), wobei die Frequenzabstimmeelemente (10) und das Steuerelement (20) so gestaltet sind, dass eine Abstimmbewegung des beweglichen Steuerelements (20) bewirkt, das die Abstimmeelemente (10) in Bezug auf die Hohlraumresonatoren (2) in Abhängigkeit von der Abstimmbewegung des Steuerelements (20) gleichzeitig verschoben werden, um die Mittenfrequenzen der Hohlraumresonatoren (2) abzustimmen, wobei jedes Frequenzabstimmeelement (10) einen Nockenfolger (12) aufweist, der aus einer Wand des zugehörigen Hohlraumresonators (2) nach außen vorsteht und der darin zu einer Verschiebewegung geführt ist, um es zu ermöglichen, die Stellung des Frequenzabstimmeelements (10) einzustellen, indem der Nockenfolger (12) weiter hinein oder heraus in Bezug auf die Hohlraumresonatorwand verschoben wird,

das Steuerelement (20) eine Nockenoberfläche (22) mit einer vorgegebenen Kontur aufweist, wobei das Steuerelement (20) und die Nockenfolger (12) in Bezug zueinander so ausgestaltet sind, dass die Nockenoberfläche in gleitendem Kontakt mit einem äußeren Ende von jedem der Nockenfolger (12) steht, wobei das Steuerelement (20) für eine lineare Bewegung entlang einer ersten Richtung gelagert ist, um die Position der Nockenoberfläche in Bezug auf die Nockenfolger (12) zu variieren, und ein Antrieb (24) dazu vorgesehen ist, um die Position des Steuerelements (20) entlang der ersten Richtung auf eine gewünschte eingestellte Position einzustellen, so dass jeder der Nockenfolger (12) und damit sein zugehöriges Frequenzabstimmeelement (10) nach Maßgabe der Kontur der Nockenoberfläche (22) eingestellt wird,

dadurch gekennzeichnet, dass

die Hohlraumresonatoren (2) durch Kopplungsöffnungen zwischen benachbarten Hohlraumresonatoren (2) gekoppelt sind, und wobei bewegliche Kopplungsabstimmeelemente (30) sich in die Kopplungsöffnungen hinein erstrecken, wobei die Kopplungsabstimmeelemente mit Nockenfolgern (32) ausgebildet sind, die in den Außenraum der Hohlraumresonatoren (2) vorstehen und die in der gleichen Weise wie die Nockenfolger (12) der Frequenzabstimmeelemente (10) verschiebbar sind, und wobei das Steuerelement (20) und die Nockenfolger (32) der Kopplungsabstimmeelemente (30) so ausgebildet sind, dass die äußeren Enden der Nockenfolger (32) in gleitendem Kontakt mit der Nockenoberfläche (22) stehen, so dass die Positionierung der Nockenoberfläche (22) zusätzlich zu der Positionierung der Frequenzabstimmeelemente (10) die Positionierung der Kopplungsabstimmeelemente (30) bestimmt.

2. Abstimmbarer Bandpassfilter nach Anspruch 1, wobei die Hohlraumresonatoren (2) in einer Reihe entlang einer ersten Richtung angeordnet sind.

3. Abstimmbarer Bandpassfilter nach einem der vorhergehenden Ansprüche, wobei der Nockenfolger (12) einen Stift umfasst, der eine abgeschrägte äußere Endspitze hat und an seinem inneren Ende ein dielektrisches Frequenzabstimmeelement (10) trägt.
4. Abstimmbarer Bandpassfilter nach einem der Ansprüche 1 oder 2, wobei der Nockenfolger (12) einen Stift mit einer abgeschrägten äußeren Endspitze hat, der an seinem inneren Ende an einem flexiblen Wandbereich (10') des Hohlraumresonators (2) anliegt, der das versetzbare Frequenzabstimmeelement bildet.
5. Abstimmbarer Bandpassfilter nach einem der vorhergehenden Ansprüche, wobei die Nockenoberfläche (22) des Steuerelements (20) eine Kontur mit einer Reihe von kontinuierlich ansteigenden Bereichen gefolgt von abfallenden Bereichen hat.
6. Abstimmbarer Bandpassfilter nach einem der vorhergehenden Ansprüche, wobei der Antrieb (24) einen Schrittmotor umfasst.
7. Abstimmbarer Bandpassfilter nach einem der vorhergehenden Ansprüche, wobei das Steuerelement (20) zur Bewegung entlang einer zweiten Richtung, die sich von der ersten Richtung unterscheidet, gelagert ist und wobei die Kontur der Nockenoberfläche entlang der ersten Richtung ($z(x)$) entlang der zweiten Richtung (y) des Steuerelements (20) variiert.
8. Abstimmbarer Bandpassfilter nach Anspruch 5, wobei das Steuerelement (20) eine Platte mit einer dreidimensionalen Nockenoberfläche ist, die eine Projektionshöhe z in Abhängigkeit von der Relativposition x, y auf der Platte definiert, wobei $z(x, y)$ die Kontur der Nockenoberfläche (22) entlang der ersten Richtung x an einer Position y entlang der weiteren Richtung definiert.
9. Abstimmbarer Bandpassfilter nach einem der vorhergehenden Ansprüche, wobei ein Kreuzkopplungsweg zwischen zwei der Hohlraumresonatoren vorgesehen ist und wobei ein bewegliches Kreuzkopplungsabstimmeelement vorgesehen ist, das in den Kreuzkopplungsweg hineinreicht, wobei das Kreuzkopplungsabstimmeelement einen Nockenfolger aufweist, der nach außen vorsteht und der in der gleichen Weise wie die Nockenfolger der Frequenzabstimmeelemente versetzbar ist, und wobei Steuerelement und Nockenfolger des Kreuzkopplungsabstimmeelements so ausgestaltet sind, dass das äußere Ende des Nockenfolgers in gleitendem Kontakt mit der Nockenoberfläche steht, so dass die Positionierung der Nockenoberfläche zusätzlich zu der Positionierung der Frequenzabstimmeelemente die Positionierung des Kreuzkopplungsabstimmeelements

bestimmt.

10. Abstimmbarer Bandpassfilter nach einem der vorhergehenden Ansprüche, wobei ein Weg zur Einkopplung elektromagnetischer Energie in den Bandpassfilter mit einem beweglichen Einkopplungsabstimmeelement vorgesehen ist, das in den Einkopplungsweg hineinreicht, wobei das Einkopplungsabstimmeelement einen Nockenfolger hat, der nach außen vorsteht und der in der gleichen Weise wie die Nockenfolger der Frequenzabstimmeelemente versetzbar ist, und wobei das Steuerelement und der Nockenfolger des Einkopplungsabstimmeelements so ausgestaltet sind, dass das äußere Ende des Nockenfolgers in gleitendem Kontakt mit der Nockenoberfläche steht, so dass die Positionierung der Frequenzabstimmeelemente die Positionierung des Einkopplungsabstimmeelements bestimmt.
11. Abstimmbarer Bandpassfilter nach einem der vorhergehenden Ansprüche, wobei ein Auskopplungsweg zum Herausführen elektromagnetischer Energie aus dem Bandpassfilter mit einem beweglichen Auskopplungsabstimmeelement vorgesehen ist, das in den Auskopplungsweg hineinreicht, wobei das Auskopplungsabstimmeelement einen Nockenfolger hat, der nach außen vorsteht und der in der gleichen Weise wie die Nockenfolger der Frequenzabstimmeelemente versetzbar ist, und wobei das Steuerelement und der Nockenfolger des Auskopplungsabstimmeelements so ausgestaltet sind, dass das äußere Ende des Nockenfolgers in gleitendem Kontakt mit der Nockenoberfläche steht, so dass die Positionierung der Nockenoberfläche zusätzlich zu der Positionierung der Frequenzabstimmeelemente die Positionierung des Auskopplungsabstimmeelements bestimmt.

Revendications

1. Filtre passe-bande accordable, comprenant une pluralité de cavités résonnantes (2), chaque cavité résonnante étant équipée d'un élément mobile (10) d'accord de fréquence s'étendant au moins partiellement dans la cavité (2), et un mécanisme de commande ayant un élément de commande mobile (20), dans lequel les éléments d'accord de fréquence (10) et l'élément de commande (20) sont agencés de façon qu'un mouvement de réglage de l'élément de commande mobile (20) provoque un déplacement simultané des éléments d'accord (10) par rapport aux cavités résonnantes (2) en fonction du mouvement de réglage de l'élément de commande (20) afin de régler les fréquences centrales des cavités résonnantes (2), dans lequel chaque élément d'accord de fréquence (10) com-

porte un galet de came (12) qui fait saillie à l'extérieur depuis une paroi de la cavité résonnante respective (2) et qui est guidé pour un mouvement de déplacement dans celui-ci afin de permettre le réglage de la position de l'élément d'accord de fréquence (10) en faisant coulisser le galet de came (12) plus loin vers l'intérieur ou l'extérieur par rapport à la paroi de la cavité résonnante ;

l'élément de commande (20) comporte une surface de guidage (22) à profil prédéterminé, l'élément de commande (20) et les galets de cames (12) étant mutuellement disposés de façon que la surface de guidage soit au contact, de manière glissante, d'une extrémité extérieure de chacun des galets de cames (12), l'élément de commande (20) étant monté pour effectuer un mouvement linéaire dans une première direction afin de modifier la position de la surface de guidage par rapport aux galets de cames (12), et un moyen d'entraînement (24) est prévu pour régler la position de l'élément de commande (20) dans la première direction afin d'obtenir une position réglée voulue de façon que chacun des galets de cames (12), et donc son élément d'accord de fréquence correspondant (10), soit réglé comme déterminé par le profil de la surface de guidage (22),

caractérisé en ce que

les cavités résonnantes (2) sont couplées par couplage d'ouvertures entre des cavités résonnantes adjacentes (2), et des éléments d'accord de couplage mobiles (30) s'étendant jusque dans les ouvertures de couplage, les éléments d'accord de couplage étant pourvus de galets de cames (32) qui font saillie à l'extérieur des cavités (2) et qui sont mobiles de la même manière que les galets de cames (12) des éléments d'accord de fréquence (10), et l'élément de commande (20) et les galets de cames (32) des éléments d'accord de couplage (30) étant disposés de façon que les extrémités extérieures des galets de cames (32) soient au contact, de manière glissante, de la surface de guidage (22) afin que la position prise par la surface de guidage (22) détermine, outre la position prise par les éléments d'accord de fréquence (10), la position prise par les éléments d'accord de couplage (30).

2. Filtre passe-bande accordable selon la revendication 1, dans lequel les cavités résonnantes (2) sont disposés en série dans la première direction.
3. Filtre passe-bande accordable selon l'une quelconque des revendications précédentes, dans lequel le galet de came (12) comporte un axe qui possède à son extrémité extérieure un bout conique et qui porte à son extrémité intérieure un élément diélectrique (10) d'accord de fréquence.
4. Filtre passe-bande accordable selon l'une quelconque des revendications 1 et 2, dans lequel le galet

de came (12) comporte un axe avec, à son extrémité extérieure, un bout conique qui, à son extrémité intérieure, bute contre une partie formant paroi flexible (10') de la cavité résonnante (2) qui constitue l'élément mobile d'accord de fréquence.

5. Filtre passe-bande accordable selon l'une quelconque des revendications précédentes, dans lequel la surface de guidage (22) de l'élément de commande (20) a un profil comportant une série de parties s'élevant de façon continue, suivies de parties descendantes. 5
6. Filtre passe-bande accordable selon l'une quelconque des revendications précédentes, dans lequel le moyen d'entraînement (24) est constitué par un moteur pas à pas. 10
7. Filtre passe-bande accordable selon l'une quelconque des revendications précédentes, dans lequel l'élément de commande (20) est monté pour se déplacer dans une seconde direction, différente de la première direction, et dans lequel le profil de la surface de guidage dans la première direction ($z(x)$) varie dans la seconde direction (y) de l'élément de commande (20). 15
8. Filtre passe-bande accordable selon la revendication 5, dans lequel l'élément de commande (20) est une plaque à surface de guidage à trois dimensions qui définit une hauteur de dépassement z dépendant de la position relative x , y sur la plaque, $z(x, y)$ définissant le profil de la surface de guidage (22) dans la première direction x à un emplacement y dans la seconde direction. 20
9. Filtre passe-bande accordable selon l'une quelconque des revendications précédentes, dans lequel un circuit de couplage transversal est prévu entre deux des cavités résonnantes et dans lequel est prévu un élément mobile d'accord de couplage transversal qui s'étend dans le circuit de couplage transversal, l'élément d'accord de couplage transversal comportant un galet de came qui fait saillie à l'extérieur et qui est mobile de la même manière que les galets de cames des éléments d'accord de fréquence, et dans lequel l'élément de commande et le galet de came de l'élément d'accord de couplage transversal sont disposés de façon que l'extrémité extérieure du galet de came soit au contact, de manière glissante, de la surface de guidage afin que la position prise par la surface de guidage détermine, outre la position prise par les éléments d'accord de fréquence, la position prise par l'élément d'accord de couplage transversal. 25
10. Filtre passe-bande accordable selon l'une quelconque des revendications précédentes, dans lequel un 30

circuit d'entrée pour appliquer une énergie électromagnétique au filtre passe-bande est pourvu d'un élément mobile d'accord d'entrée qui s'étend dans le circuit d'entrée, l'élément d'accord d'entrée comportant un galet de came qui fait saillie à l'extérieur et qui est mobile de la même manière que les galets de cames des éléments d'accord de fréquence, et dans lequel l'élément de commande et le galet de came de l'élément d'accord d'entrée sont disposés de façon que l'extrémité extérieure du galet de came soit au contact, de manière glissante, de la surface de guidage afin que la position prise par la surface de guidage détermine, outre la position prise par les éléments d'accord de fréquence, la position prise par l'élément d'accord d'entrée. 35

11. Filtre passe-bande accordable selon l'une quelconque des revendications précédentes, dans lequel un circuit de sortie pour extraire une énergie électromagnétique du filtre passe-bande est pourvu d'un élément mobile d'accord de sortie qui s'étend dans le circuit de sortie, l'élément d'accord de sortie comportant un galet de came qui fait saillie à l'extérieur et qui est mobile de la même manière que les galets de cames des éléments d'accord de fréquence, et dans lequel l'élément de commande et le galet de came de l'élément d'accord de sortie sont disposés de façon que l'extrémité extérieure du galet de came soit au contact, de manière glissante, de la surface de guidage afin que la position prise par la surface de guidage détermine, outre la position prise par les éléments d'accord de fréquence, la position prise par l'élément d'accord de sortie. 40

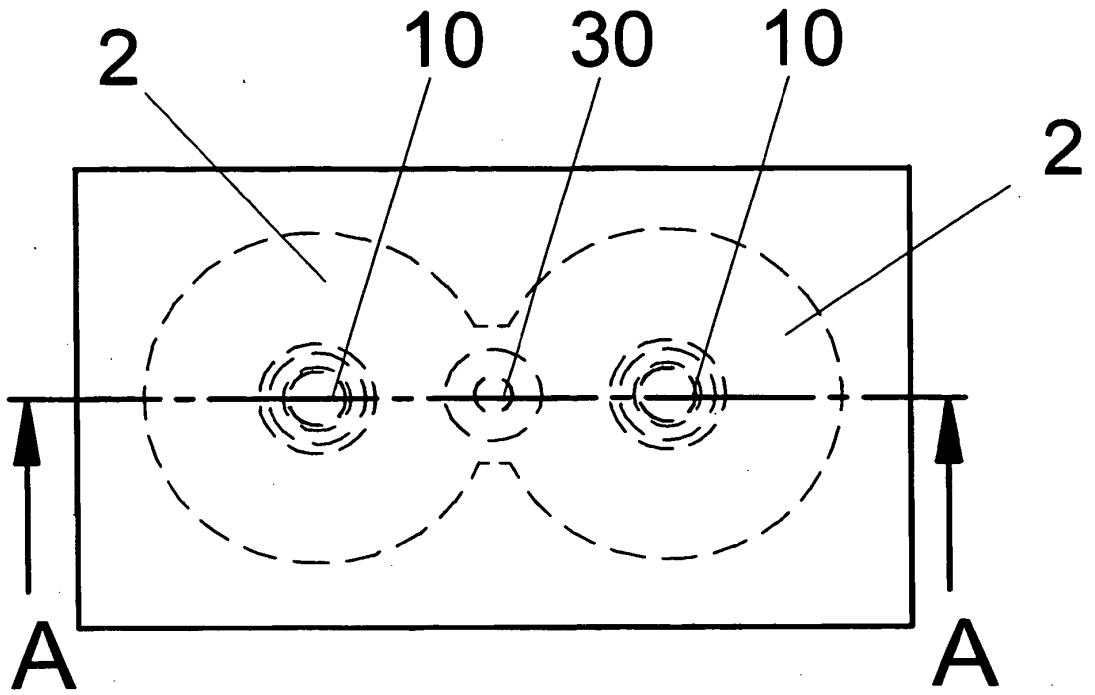

Fig. 2

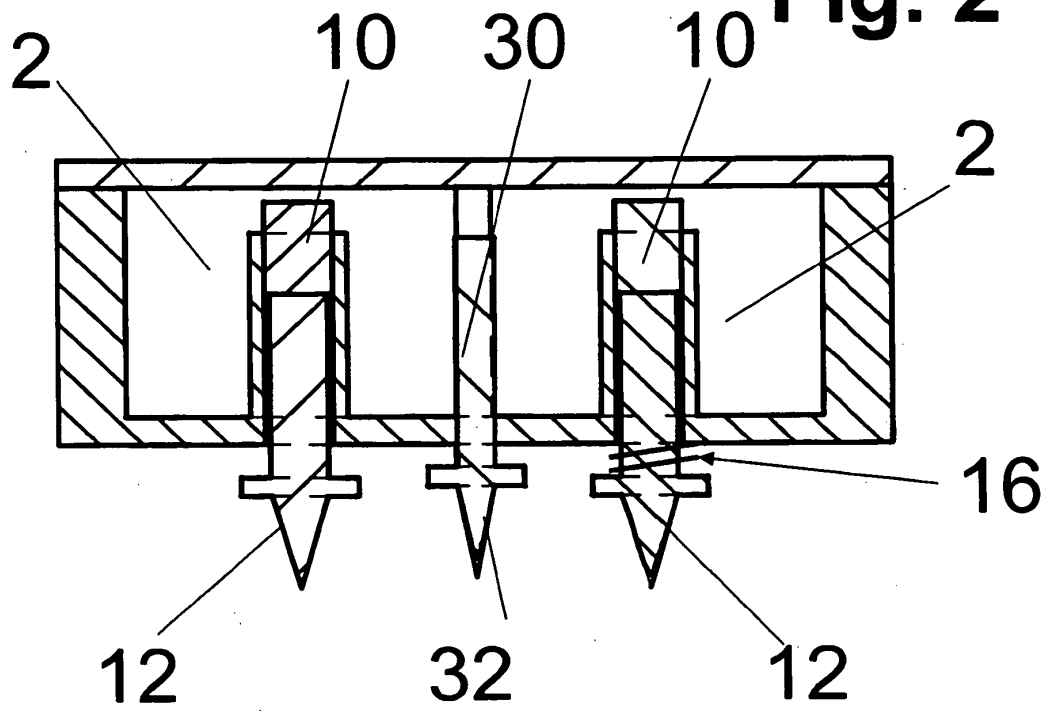

Fig. 1

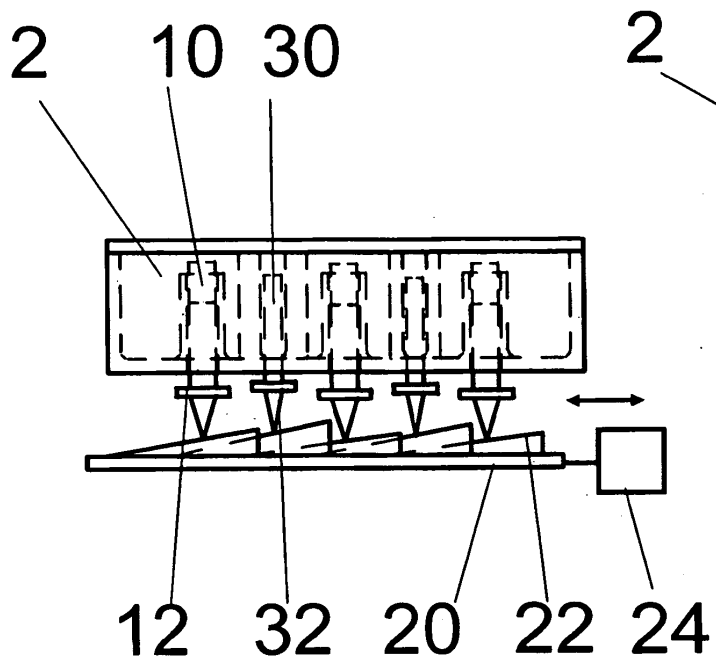

Fig. 3

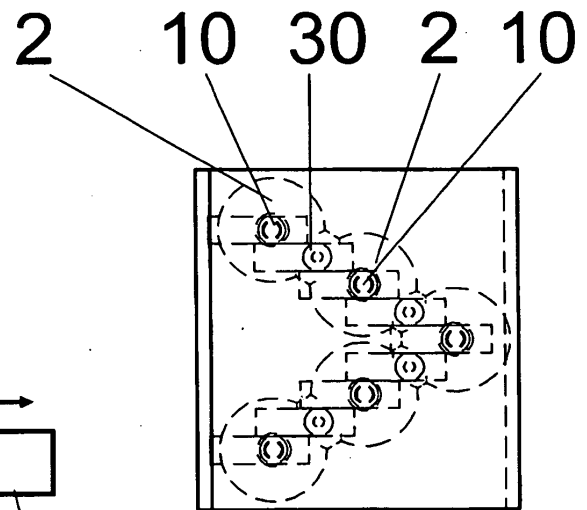

Fig. 4

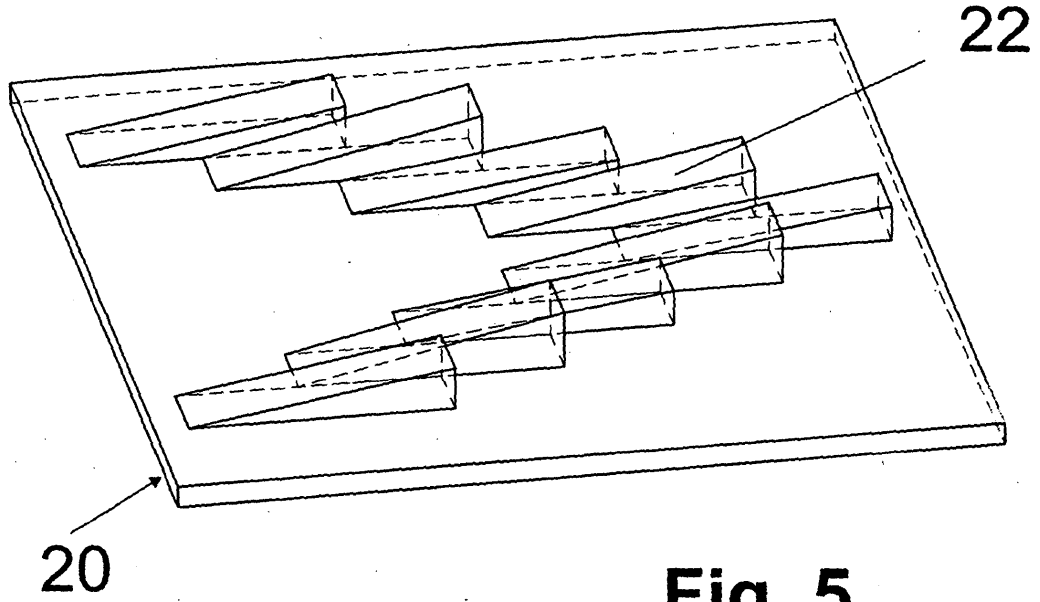

Fig. 5

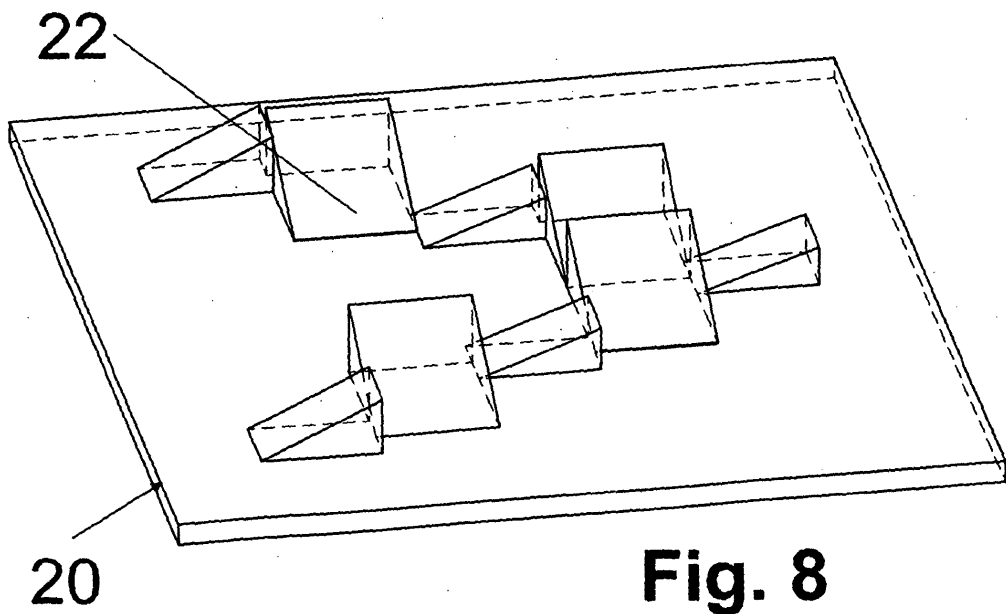

Fig. 8

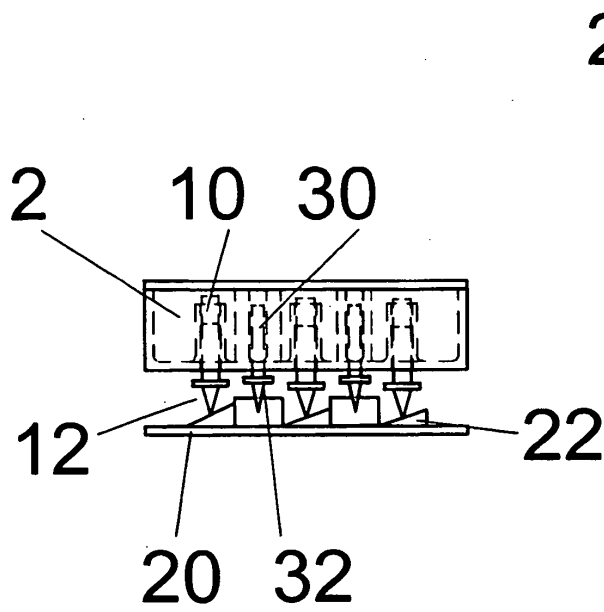

Fig. 6

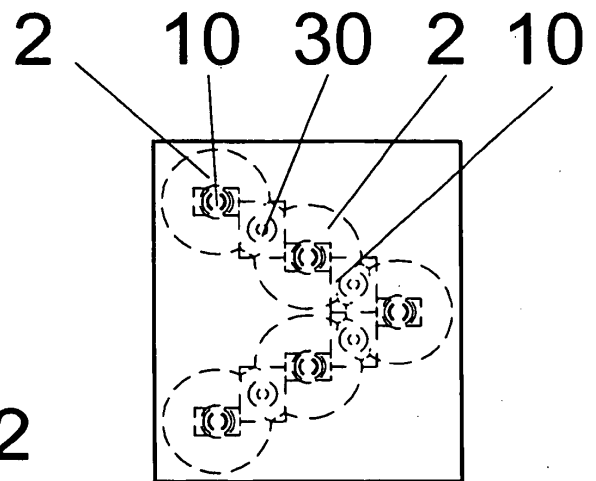
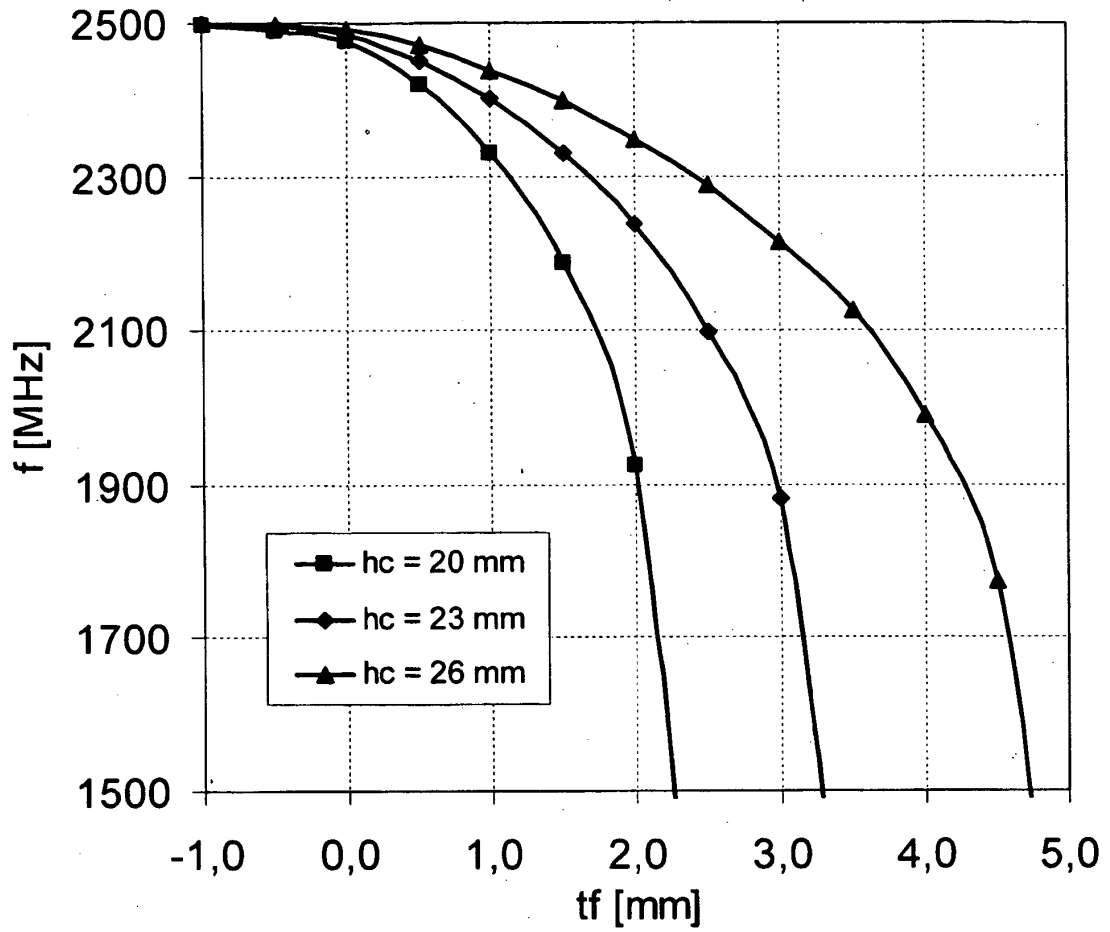

Fig. 7

**Fig. 9**

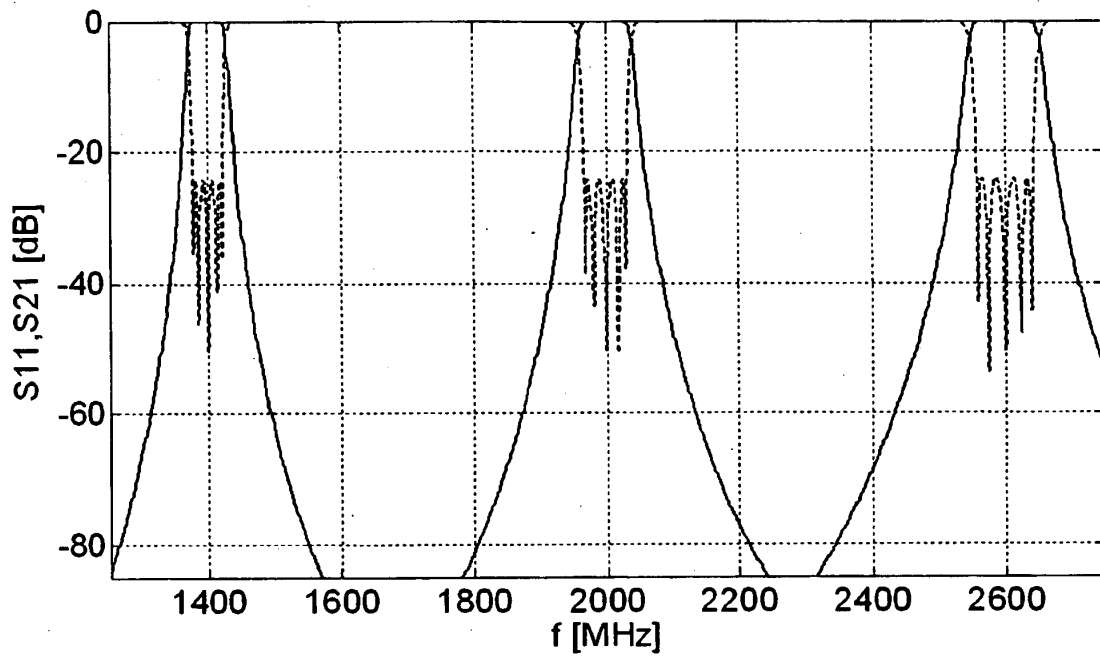

Fig. 10

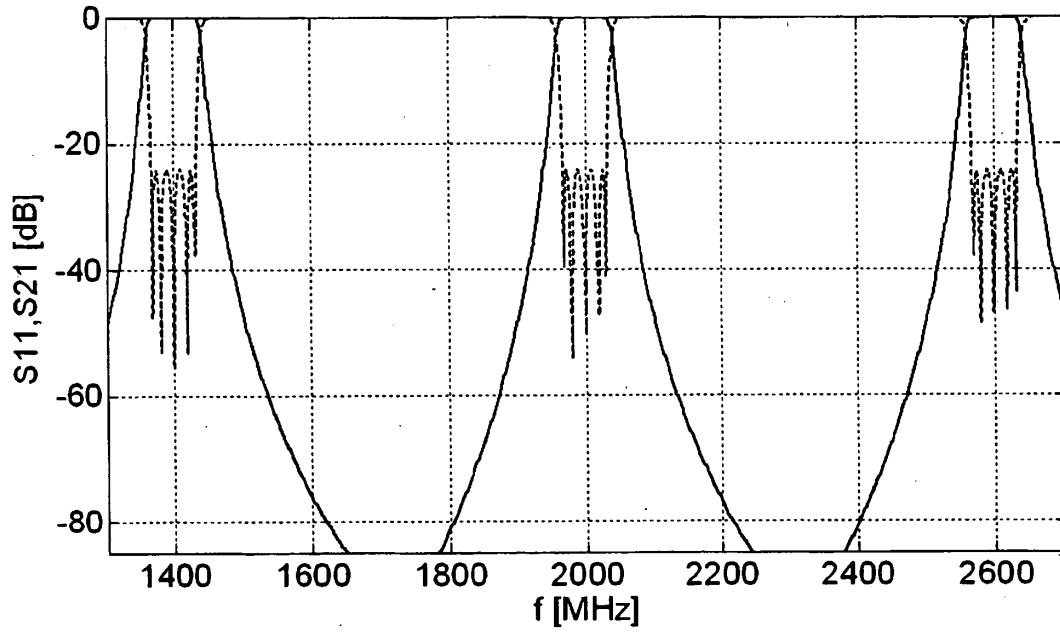

Fig. 11

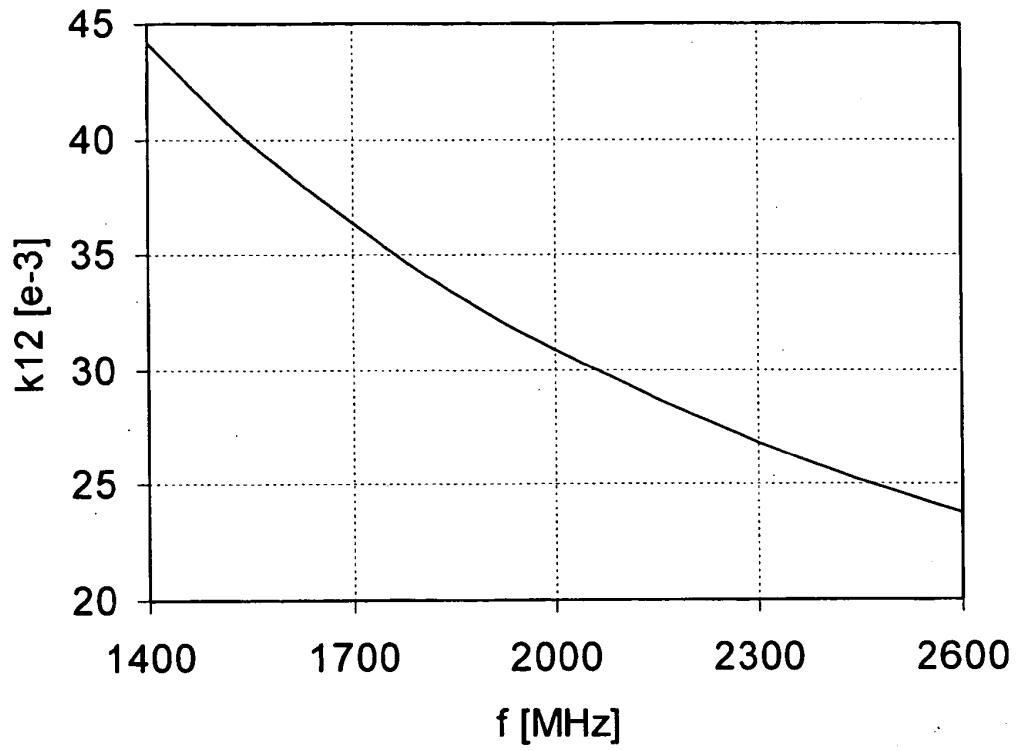

Fig. 12

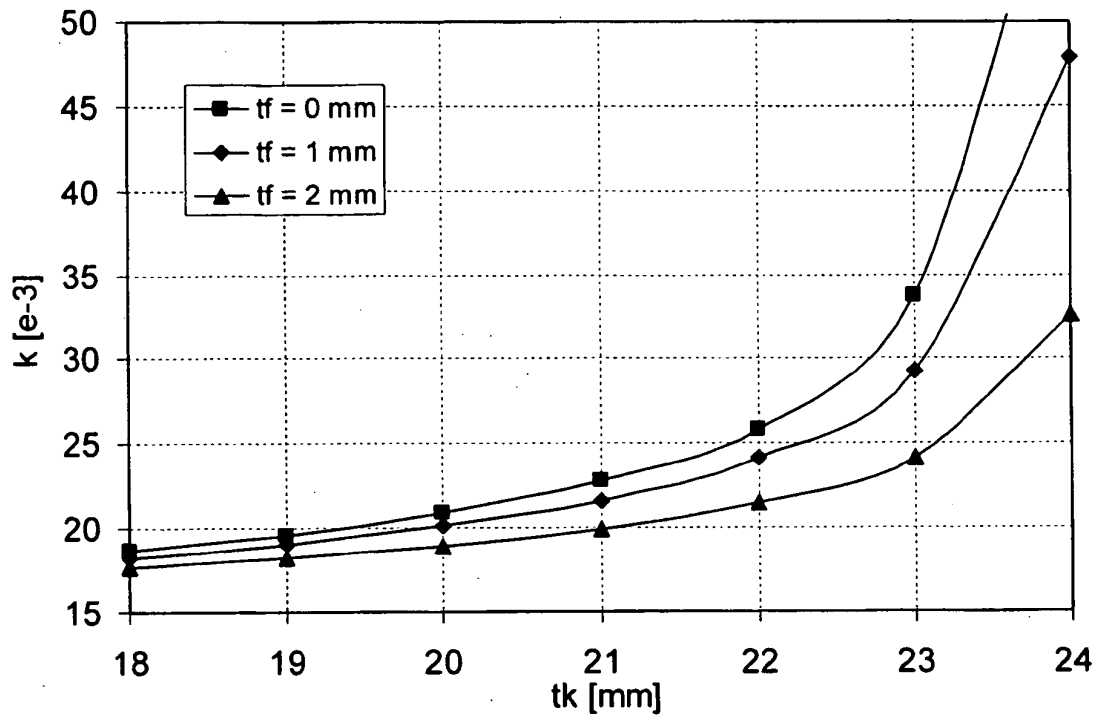

Fig. 13

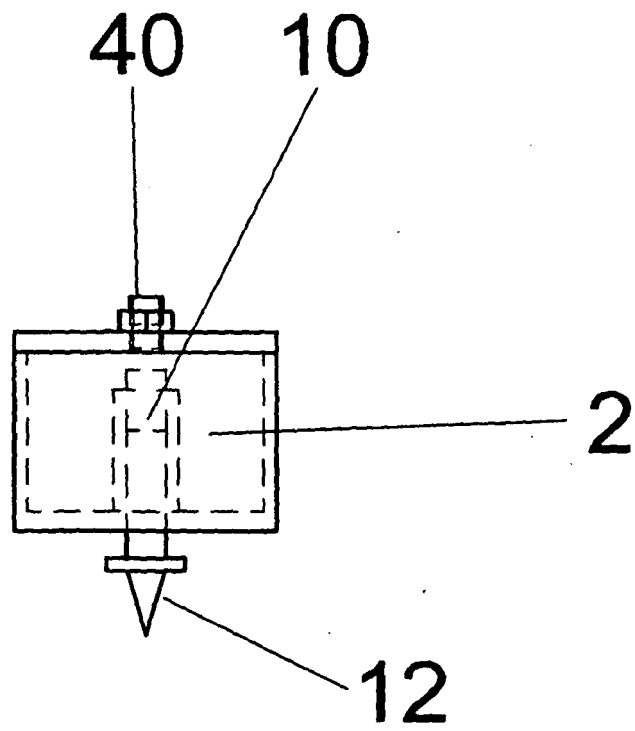

Fig. 14

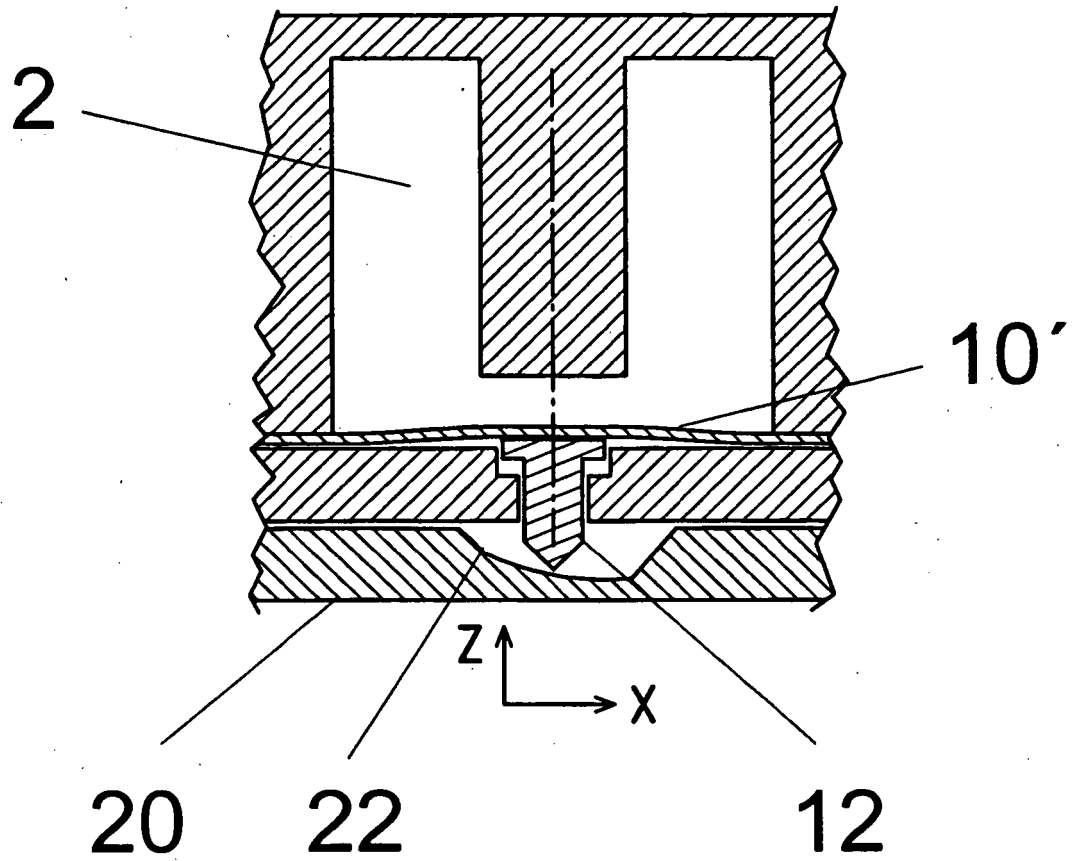

Fig. 15

REFERENCES CITED IN THE DESCRIPTION

This list of references cited by the applicant is for the reader's convenience only. It does not form part of the European patent document. Even though great care has been taken in compiling the references, errors or omissions cannot be excluded and the EPO disclaims all liability in this regard.

Patent documents cited in the description

- US 20050212623 A [0002]
- US 20060038640 A1 [0003]
- US 3838308 A [0005]