

E. T. HARVEY.
 COMBINATION SHOVEL, PLOW, AND SCRAPER.
 APPLICATION FILED MAY 24, 1910.

992,871.

Patented May 23, 1911.

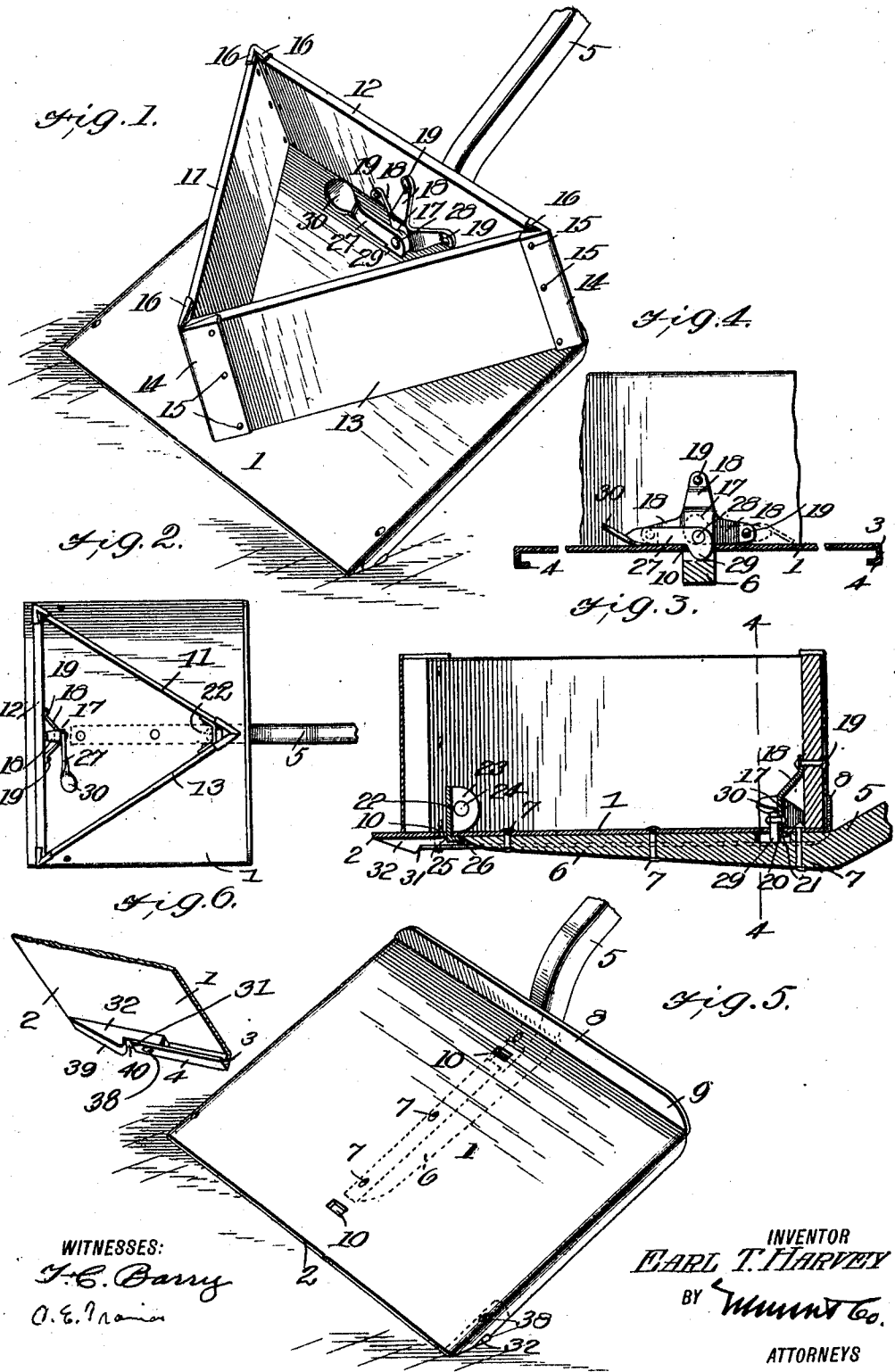

WITNESSES:
J. C. Barry
O. E. ? name

INVENTOR
E. T. HARVEY
 BY *Wm. W. Co.*
 ATTORNEYS

UNITED STATES PATENT OFFICE.

EARL THOMAS HARVEY, OF SALT LAKE CITY, UTAH.

COMBINATION SHOVEL, PLOW, AND SCRAPER.

992,871.

Specification of Letters Patent.

Patented May 23, 1911.

Application filed May 24, 1910. Serial No. 563,050.

To all whom it may concern:

Be it known that I, EARL T. HARVEY, a citizen of the United States, and a resident of Salt Lake City, in the county of Salt Lake and State of Utah, have made certain new and useful Improvements in a Combination Shovel, Plow, and Scraper, of which the following is a specification.

My invention is an improvement in a combination shovel, plow, and scraper, and consists in certain novel constructions, and combinations of parts hereinafter described and claimed.

The object of the invention is to provide a cheap and simple tool of the character specified, especially designed for removing snow, and which with slight changes may be used as a shovel in the ordinary manner, as a scraper to loosen and scrape up the snow, as a pusher to push the accumulation, or as a plow to throw the snow to each side.

Referring to the drawings forming a part hereof, Figure 1 is a perspective view of the improvement for use as a plow, Fig. 2 is a top plan view with the tool arranged for use as a scraper or pusher, Fig. 3 is a transverse section, Fig. 4 is a section on the line 4-4 of Fig. 3, Fig. 5 is a perspective view of the tool, for use as a shovel, and Fig. 6 is a partial perspective view.

The embodiment of the invention shown in the drawings, consists of a plate 1, preferably of metal, having its front edge 2 sharpened, and having at each end a downwardly projecting lateral flange 3, and the extremity of the flange is bent over inwardly as at 4 substantially parallel with the plate. A handle 5 of suitable size, shape and material is provided with an offset tapered portion 6, arranged transversely of the lower face of the plate, and secured to the plate by rivets 7, the said handle stopping short of the front edge of the plate as shown in Figs. 3 and 5. The rear edge of the plate is flanged at 8, the flange extending upwardly, and being rounded off at each end as shown at 9, and at its transverse center the plate is provided near each side edge with a transverse opening 10.

A plow consisting of a substantially triangular frame is detachably connected with the plate, the said frame consisting of three sides 11, 12 and 13 of equal length and

width, connected at their ends by angle plates 14, which are secured to the sides by rivets 15, and the ends of the angle plates are lapped over on the edges of the sides as shown at 16. One of the sides 12 of the frame is slightly thicker than the other and is designated as the base, and a bracket 17 is secured to the inner face of the said side at the center of one side edge. The bracket is provided with three legs 18, each of which is secured to the side by a rivet 19. The bracket 17 is provided with a lug 20 which is adapted to extend through one of the slots 10 when the triangular frame is properly positioned with respect to the plate, and the lug has an angular portion 21 which engages beneath the plate to prevent upward movement of the frame. At the apex of the frame, a plate 22 is arranged transversely, and the ends 23 of the plate are bent angularly and riveted to the sides of the frame by rivets 24. The plate is provided with a depending lug 25 adapted to pass through the other opening 10 of the plate, and the said lug has an angular portion 26 for engaging beneath the plate to prevent upward movement of the frame.

A latch 27 is pivoted to the bracket 17 at 28, and is provided at one end with a cam 29 eccentric to the pivot, and at the other with a finger piece 30. The cam is adapted to pass through the opening 10 with the lug 20, and when the finger piece 30 is depressed, the end of the cam enters the opening 10 and holds the lug 20 in place and with it the frame.

By lifting the finger piece, the frame may be moved laterally toward the front of the shovel, the slots 10 being of sufficient width to permit this movement, and being also of sufficient width to permit the passage of the angular portions, when properly positioned with respect to the slots.

When it is desired to use the device as a snow shovel, the frame is removed in the manner just described and the tool is used in the manner of the ordinary shovel. When the frame is arranged as shown in Fig. 1, with the apex of the frame to the front, an efficient plow is provided, and when the base of the frame is at the front, the snow may be pushed out of the way. When so arranged, the edge of the plate extends

beyond the base of the frame. When the apex of the frame is at the front, the outer face of the base fits against the flange 8, as shown in Fig. 3, and in all positions of the frame, the edge of the plate extends beyond the frame to act as a scraper for loosening the packed snow and ice.

As shown in Fig. 6 the portion 4 of the flange 3 of the plate does not extend to the front edge of the shovel but is cut away at 31, and a block 32 is secured to the plate by a rivet 38 at this point, the block having a beveled front end 39, and a notch 40 behind the beveled end, and the portion 4 of the flange overlaps the block and is riveted to the block by the rivet 38. The beveled ends of the blocks act as guards to properly position the shovel, so that the free edge will act in the most efficient manner. The length of the base 12 of the frame is substantially the same as the length of the plate, so that the snow is cleared the full width of the shovel.

I claim—

1. A device of the character specified, comprising a plate having at one side edge an upwardly extending flange and having at its ends downwardly extending overlapping flanges, and provided with slots near each side edge at its transverse center, a handle having an offset portion arranged transversely of the center of the plate and secured thereto, a triangular frame having at its apex and at the center of its base downwardly extending lugs for engaging the slots, each of said lugs having angular portions for engaging beneath the plate, said portions extending in the same direction, and a catch pivoted to the base at its center, and having at one end a cam eccentric to the pivot and passing through the slot with the lug, said catch having at the other end a finger piece for manipulating the same.

2. A device of the character specified, comprising a plate having at one side edge an upwardly extending flange and having at its ends downwardly extending overlapping flanges, and provided with slots near each side edge at its transverse center, a handle having an offset portion arranged transversely of the center of the plate and secured thereto, a triangular frame having at its apex and at the center of its base downwardly extending lugs for engaging the slots, each of said lugs having angular portion for engaging beneath the plate, said portions extending in the same direction, and a catch pivoted to the base at its center, having at one end a cam eccentric to the pivot and passing through the slot with the lug.

3. A device of the character specified, comprising a plate having at one side edge an upwardly extending flange, and having at its ends downwardly extending overlapping

flanges, and provided with slots near each side edge at its transverse center, a handle having an offset portion arranged transversely of the center of the plate and secured thereto, a triangular frame having at its apex and at the center of its base downwardly extending lugs for engaging the slots, each of said lugs having angular portion for engaging beneath the plate, said portions extending in the same direction, and a catch pivoted to the base at its center, for preventing disengagement of the lugs.

4. A device of the character specified, comprising a plate having at one side edge an upwardly extending flange and having at its ends downwardly extending overlapping flanges, and provided with slots near each side at its transverse center, a handle having an offset portion arranged transversely of the center of the plate and secured thereto, a triangular frame having at its apex and at the center of the base downwardly extending lugs for engaging the slots, each of said lugs having angular portions for engaging beneath the plate, and means for preventing disengagement of the lugs.

5. A device of the character specified, comprising a plate having at one side edge an upwardly extending flange and having at its ends downwardly extending overlapping flanges; and provided with slots near each side edge at its transverse center, a handle having an offset portion arranged transversely of the center of the plate and secured thereto, an open triangular frame, and means for detachably connecting the frame to the upper face of the plate, with one side thereof adjacent to and in parallelism with either edge of the plate.

6. A device of the character specified, comprising a plate, a handle arranged transversely of the center thereof, and secured thereon, and extending laterally therefrom, a substantially triangular open frame having at the center of one side and at the angle opposite the said side a downwardly projecting lug provided with an angular portion, said portions extending in the same direction, the plate having a slot near each side edge and in line with the handle for receiving the lugs, and a latch pivoted to the side provided with the lug and having a cam portion extending through the adjacent slot for preventing lateral movement of the lugs in the slots.

7. A device of the character specified, comprising a plate, a handle arranged transversely of the center thereof and secured thereon, and extending laterally therefrom, a substantially triangular open frame having at the center of one side and at the angle opposite the said side a downwardly projecting lug provided with an angular portion, said portions extending in the same direction, the plate having a slot near each side edge

and in line with the handle for receiving the lugs, and means for preventing lateral movement of the lugs in the slots.

8. A device of the character specified, comprising a plate, a handle arranged transversely of the center thereof, and secured thereon, and extending laterally therefrom, a substantially triangular open frame, and means for securing the frame to the upper
10 face of the plate with one of its sides parallel with the front or the rear edge thereof.

9. A device of the character specified, comprising a plate, a handle connected with the plate, a substantially triangular open
15 frame, and means for connecting the frame

with the plate with one of its sides adjacent to and substantially parallel to the front or the rear edge of the plate.

10. A device of the character specified comprising a plate, a handle connected to the
20 plate, a plow substantially triangular in cross section, and means for detachably connecting the plow to the upper face of the plate with its apex toward the front or the rear of the plate.

EARL THOMAS HARVEY.

Witnesses:

FRANK CROCKER,
ELIZABETH V. FRITZ,
L. L. SAMSON.

Copies of this patent may be obtained for five cents each, by addressing the "Commissioner of Patents, Washington, D. C."
