



INTERNATIONAL APPLICATION PUBLISHED UNDER THE PATENT COOPERATION TREATY (PCT)

<p>(51) International Patent Classification ⁶ : G01D 11/30, G01P 1/00, F16B 5/02</p>	<p>A1</p>	<p>(11) International Publication Number: WO 95/29384 (43) International Publication Date: 2 November 1995 (02.11.95)</p>
--	------------------	--

(21) International Application Number: PCT/US95/05079
 (22) International Filing Date: 25 April 1995 (25.04.95)
 (30) Priority Data:
 08/232,564 25 April 1994 (25.04.94) US
 (71) Applicant: HONEYWELL INC. [US/US]; Honeywell Plaza, Minneapolis, MN 55408 (US).
 (72) Inventor: ALFORS, Eugene, D.; 6170 Conner Lane, Rockford, IL 61109 (US).
 (74) Agent: LANYI, William, D.; Honeywell Inc., Honeywell Plaza - MN12-8251, Minneapolis, MN 55408 (US).

(81) Designated States: JP, European patent (AT, BE, CH, DE, DK, ES, FR, GB, GR, IE, IT, LU, MC, NL, PT, SE).
Published
 With international search report.
 Before the expiration of the time limit for amending the claims and to be republished in the event of the receipt of amendments.

(54) Title: APPARATUS AND METHOD FOR ATTACHING A SENSOR TO AN OBJECT

(57) Abstract

An apparatus and method are provided for attaching a gear tooth sensor to an object, such as an engine block of an automobile. A clamping bar and a deformable conical washer are associated with a tubular portion of the sensor in such a way that rigid attachment of the clamping bar to the engine block, such as through the use of a threaded bolt, deforms the conical washer into a generally flat shape and, in the process, causes a distal end of the tubular portion of the sensor to move away from a target by a predetermined distance. Prior to deforming the deformable washer between the clamping bar and the engine block, the sensor is moved into contact with a rotatable target, such as a gear. The distal end of the tubular portion being in contact with the target, the clamping bar is used to compress and deform the washer so that the deformation of the washer causes the distal end of the tubular portion to move away from the target by a predetermined amount that results in an accurately set gap between a magnetically sensitive component within the sensor and the teeth of the rotatable target.

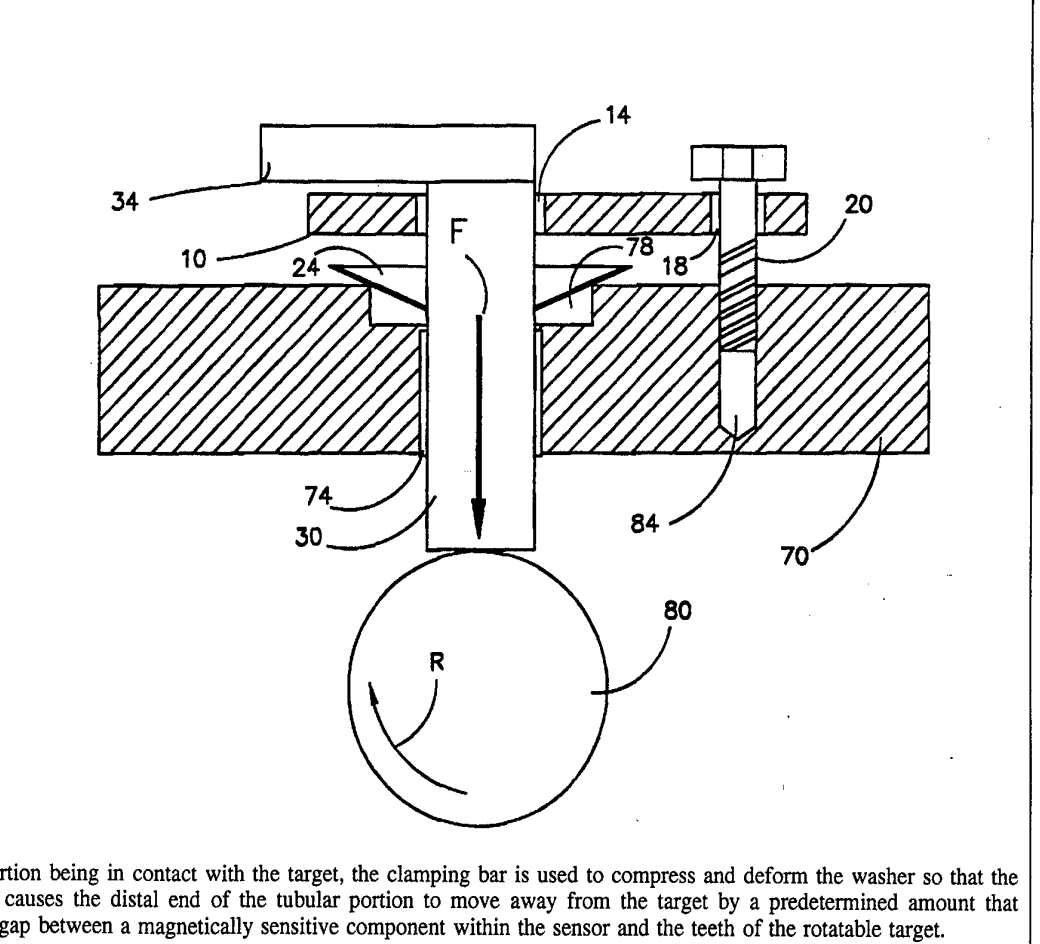

FOR THE PURPOSES OF INFORMATION ONLY

Codes used to identify States party to the PCT on the front pages of pamphlets publishing international applications under the PCT.

AT	Austria	GB	United Kingdom	MR	Mauritania
AU	Australia	GE	Georgia	MW	Malawi
BB	Barbados	GN	Guinea	NE	Niger
BE	Belgium	GR	Greece	NL	Netherlands
BF	Burkina Faso	HU	Hungary	NO	Norway
BG	Bulgaria	IE	Ireland	NZ	New Zealand
BJ	Benin	IT	Italy	PL	Poland
BR	Brazil	JP	Japan	PT	Portugal
BY	Belarus	KE	Kenya	RO	Romania
CA	Canada	KG	Kyrgystan	RU	Russian Federation
CF	Central African Republic	KP	Democratic People's Republic of Korea	SD	Sudan
CG	Congo	KR	Republic of Korea	SE	Sweden
CH	Switzerland	KZ	Kazakhstan	SI	Slovenia
CI	Côte d'Ivoire	LI	Liechtenstein	SK	Slovakia
CM	Cameroon	LK	Sri Lanka	SN	Senegal
CN	China	LU	Luxembourg	TD	Chad
CS	Czechoslovakia	LV	Latvia	TG	Togo
CZ	Czech Republic	MC	Monaco	TJ	Tajikistan
DE	Germany	MD	Republic of Moldova	TT	Trinidad and Tobago
DK	Denmark	MG	Madagascar	UA	Ukraine
ES	Spain	ML	Mali	US	United States of America
FI	Finland	MN	Mongolia	UZ	Uzbekistan
FR	France			VN	Viet Nam
GA	Gabon				

APPARATUS AND METHOD FOR ATTACHING A SENSOR TO AN OBJECT**BACKGROUND OF THE INVENTION****Field of the Invention:**

The present invention is generally related to position sensors and, more
5 specifically, to a method and apparatus for attaching a gear tooth sensor to an
automobile engine in such a way that the distal end of the sensor is positioned at a
precise location relative to a rotatable target.

Description of the Prior Art:

Many different types of sensors are known to those skilled in the art and many
10 varieties of gear tooth sensors are also well known. In operation, a gear tooth sensor, or
proximity sensor, typically comprises a permanent magnet in association with a
magnetically sensitive component such as a Hall effect element or a magnetoresistive
element. Sensors of this type are constructed in such a way that a ferromagnetic
15 component passing through a predefined detection zone will cause the magnetically
sensitive component to provide a signal identifying this event. The ferromagnetic object
can be the teeth of a gear, whether or not the gear is intended to operate in the traditional
manner of a gear or merely to provide a plurality of teeth extending from a rotatable
target, in order to facilitate the detection of the teeth for the purpose of sensing the
angular position or velocity of the rotating target. Devices of this type find many
20 applications in automobiles, including sensors which monitor the position of crank
shafts and cam shafts and, in addition, sensors which are used in automatic braking
systems. A problem which occurs when sensors of this type are installed relative to a
rotatable target is that the gap between the distal end, or operative end, of the sensor and
the target must be maintained with a relatively high degree of accuracy. Otherwise, the
25 signal level provided by the magnetically sensitive component of the sensor will not be
properly calibrated to the angular position of the target.

United States Patent 4,677,378, which issued to Tokura et al on June 30, 1987,
discloses a displacement sensor which has a magnetically responsive member and a pair
of piezoelectric elements. The sensor is provided with first and second piezoelectric
30 elements, a pair of electrodes at one and the other ends of each of the first and second
piezoelectric elements and a permanent magnet mechanically fixed to one end of the
first piezoelectric element. In addition, it provides a small piece which is mechanically

fixed to one end of the second piezoelectric element and has approximately the same weight as the permanent magnet. A base plate to which the other ends of the first and second piezoelectric elements are mechanically fixed is provided wherein the electrodes provided at the other end of each of the first and second piezoelectric elements are electrically connected. The electrodes provided at one end of each of the first and second piezoelectric elements are used as output terminals. In addition, a pair of small pieces made of a magnetic material and a nonmagnetic material can be used instead of the permanent magnet and small piece.

United States Patent 5,121,289, which issued to Gagliardi on June 9, 1992, describes an encapsulatable sensor assembly. The description in the Gagliardi patent shows the inner construction of a gear tooth sensor which comprises a permanent magnet and a magnetically sensitive component. The assembly includes an external housing with internal support components for retaining an active sensor element and associated electrical circuitry in a predetermined relationship while providing a plurality of internal sequentially interconnected cavities for facilitating a flow of an encapsulating material from an injection port to a vented overflow in order to assure a complete fill of the internal cavities to restrain the internal components. The sensor assembly provides a structure for a void free encapsulation and internal leadwire stress relief concurrently with location control of the internal component while also providing a combination which is easily adaptable to automatic assembly and encapsulation techniques.

United States Patent 5,140,262, which issued to Stolfus on August 18, 1992, discloses a gear tooth sensor with a centerline in nonintersecting relation with a center of rotation of a rotatable member. The off-axis gear tooth sensor is provided with a centerline of the sensor that is disposed along a line which is not coincident with the center of rotation of the rotatable member to be sensed. Instead, the centerline of the housing in which a Hall effect element is disposed is positioned at a perpendicular distance from the center of rotation of the rotatable member which is determined as the function of range of dimensions which define the allowable gap between the Hall effect element and a surface of the rotatable member. The perpendicular distance between the center of rotation and the line along which the proximity sensor is disposed is mathematically determined as a function of the distances between the center of rotation of the rotatable member and the minimum and maximum possible locations of the Hall

effect element along with the angular distance between those two dimensions. The sensor provides a gear tooth sensor which is significantly immune to changes in the gap between a Hall effect element and the surface of a rotatable member which is being sensed. The rotatable member is provided with at least one discontinuity in its surface which causes changes in the magnetic field surrounding a Hall effect element and, as a result, provides a signal from the Hall effect element to indicate the proximity of the discontinuity to the Hall effect element.

The Tokura et al patent shows the relative position of a gear tooth sensor to the rotatable target comprising a plurality of gear teeth. The Gagliardi patent shows the internal structure of a gear tooth sensor with a permanent magnet and a magnetically sensitive component disposed internally and proximate a distal end of the sensor. The Stolfus patent shows one particular technique that has been used in order to reduce the sensitivity of a gear tooth sensor to variations in the position of the distal end of the sensor relative to a rotatable target. Accuracy in the position of the sensor relative to the target is very important to the proper operation of the sensor.

It would therefore be significantly beneficial to the field of gear tooth sensing if a means could be provided which allows the gap between a distal end of a gear tooth sensor and a rotatable target to be accurately set without the need of expensive and time consuming techniques and without the need for complex measurements and procedures.

SUMMARY OF THE INVENTION

The present invention provides an apparatus and method for installing a gear tooth sensor in an automobile engine without the need for complex measurements and procedures. In addition, the present invention permits the distal end of the gear tooth sensor to be accurately located at a predefined distance from the rotatable target without the need for time consuming and expensive processes. The apparatus of the present invention comprises a sensor which has a generally tubular portion. In addition, a deformable washer is shaped to be slideably disposable over the tubular portion of the sensor. A clamping bar is provided with an opening therethrough that is shaped to slideably receive the tubular portion of the sensor therein. A third opening is formed through the bar. A threaded bolt is shaped to slide through the third opening of the clamping bar. The bolt is engagable in threaded association with a hole in the object, such as an automobile engine block. The deformable washer is compressible between

the clamping bar and the object and is thereby deformed in such a way that it compresses the edges of its opening into rigid attachment with the tubular portion of the sensor when the bolt is tightened to compress the clamping bar against the object. The tubular portion of the sensor is axially moved from a first position to a second position
5 as a result of the washer being deformed between the clamping bar and the object.

In a particularly preferred embodiment of the present invention, the sensor is a magnetically sensitive device and the object is an automobile engine block. Also in a preferred embodiment of the present invention, the washer is in the shape of a frustum of a cone, such as a Belleville washer. The tubular portion of the sensor can have a
10 generally circular cross section or a noncircular cross section, depending on the particular design and application of the sensor. When the sensor is initially installed relative to the object, the distal end of the tubular portion of the sensor is placed in contact with a rotatable object to be sensed when in the first position described above and the distal end is spaced apart from the rotatable object to be sensed by a
15 predetermined gap when in the second position described above. In one embodiment of the present invention, the deformable washer and the tubular portion of the sensor are shaped to result in a slight deformation of the tubular portion when the washer is deformed by being compressed between the bar and the object.

In order to perform the method of the present invention, a preferred embodiment
20 provides a sensor which has a tubular portion and disposes the tubular portion through an opening formed through a clamping bar. In addition, the method of the present invention disposes the tubular portion through an opening formed through a deformable washer and inserts the tubular portion into an opening of the object until a distal end of the tubular portion touches the target. The present invention then forces the clamping
25 bar toward the object in order to deform the washer between the object and the clamping bar, wherein the washer is deformed to cause the distal end of the tubular portion to move away from the target by a predetermined distance. In a preferred embodiment of the present invention, the compressing step comprises the step of inserting a bolt through the clamping bar and into the object and then tightening the bolt into the object.

30 The present invention provides an apparatus and method which allows a sensor to be inserted into an engine block of an automobile until it touches the target with its distal end. As the sensor is inserted into the engine block, the deformable washer is

forced along the tubular portion of the sensor as the washer is disposed in contact with a portion of the engine block and the tubular portion is pushed through the deformable washer into the engine block. With the distal end of the tubular portion in contact with the rotatable target, the clamping bar is tightened through the use of bolt until it moves
5 toward the engine block and compresses the deformable washer. When the deformable washer is compressed, it assumes a generally flat shape. During the deformation, the inner circular edge around the opening of the washer compresses into the tubular portion of the sensor and becomes rigidly attached to it. As the deformation of the washer continues, the inner edge of the washer is caused to move away from the target and,
10 because of the attachment between the washer and the sensor, the sensor is pulled away from the target by a preselected distance. When the washer assumes its final flat shape, the distal end of the sensor is a predefined and accurately determined distance from the rotatable target and the appropriate gap between the magnetically sensitive component and the teeth of the target is set.

15

BRIEF DESCRIPTION OF THE DRAWINGS

The present invention will be more fully understood from a reading of the Description of the Preferred Embodiment in conjunction with the drawings, in which:
Figure 1 shows a clamping bar used in association with the present invention;
Figure 2 shows a bolt that is usable in conjunction with the clamping bar of
20 Figure 1;
Figure 3 shows a deformable washer that used in a preferred embodiment of the present invention;
Figure 4 shows a sensor such as that generally known in the art as a gear tooth sensor;
25 Figure 5 shows the present invention associated with a gear tooth sensor prior to clamping a clamping bar against an object to deform the deformable washer shown in Figure 3;
Figure 6 shows the arrangement of Figure 5 after the clamping bar is rigidly compressed against the object;
30 Figure 7 is an illustration of a sensor, the clamping bar and the deformable washer associated together prior to insertion an opening of an object such as an automobile engine;

Figure 8 is an exploded view illustrating the relative positions of the sensor, the clamping bar, the deformable washer and the external object to which the sensor is to be attached;

Figure 9 illustrates the deformable washer of the present invention in contact
5 with the edge of the counterbore prior to deformation; and

Figure 10 shows the relationship between the deformable washer and the counterbore of the object following deformation.

DESCRIPTION OF THE PREFERRED EMBODIMENT

Throughout the Description of the Preferred Embodiment, like components will
10 be identified by like reference numerals.

Figure 1 shows a clamping bar 10 which is provided with two openings. A first opening 14 is shaped to receive a tubular portion of a sensor in slideable association therein and a second opening 18 is shaped to receive the shank of a bolt in slideable relationship therein.

15 Figure 2 shows a bolt 20 that is provided with a threaded shank and a hex-head. However, it should be realized that any means for a rigidly attaching the clamping bar 10 to an object is suitable for use with the present invention.

Figure 3 is a deformable washer 24 that is generally conical in shape. An opening 28 is formed in the central portion of the washer. As illustrated in Figure 3, the
20 generally conical shape of the washer provides a thickness T in the vertical dimension. Although many different types of deformable washers can be used in association with the present invention, a Belleville washer is suitable for these purposes.

Figure 4 illustrates a typical gear tooth sensor which has a tubular portion 30 and an attachment flange 34 in certain types of sensors. However, it should be realized that
25 the attachment flange 34 is not necessary on all types of sensors. In fact, the gear tooth sensor described in the Stolfus patent does not utilize this component. Inside the tubular portion 30, a permanent magnet 38 and a magnetically sensitive component 40 are associated together so that the magnetic field provided by the permanent magnet 38 impinges on the magnetically sensitive component 40. Therefore, distortions of the
30 magnetic field caused by ferromagnetic objects passing through a predefined detection zone can be sensed by the magnetically sensitive component 40. The magnetically sensitive component can be a Hall effect element or a permalloy bridge arrangement.

The particular type of magnetically sensitive component used in the gear tooth sensor is not limiting to the operation of the present invention. Conductive wires 44 and 46 can extend from a rear portion of the gear tooth sensor so that a connector 50 can be used for connecting the gear tooth sensor to other electrical components of the automobile system or other system where the sensor is used. The tubular portion 30 has a distal end 60 at which the magnetically sensitive component 40 is disposed.

Figure 5 shows the assembly of a gear tooth sensor in association with an object 70. Although a simplified schematic illustration of the object 70 is shown in the Figures, it should be understood that, in a typical application of the present invention, the object 70 is a portion of the engine block of an automobile. An opening 74 is formed in the object 70 and an associated opening 76, such as a counterbore, is provided in an external surface of the object 70. The clamping bar 10 is disposed around the tubular portion 30 of the sensor. The opening 14 in the clamping bar 10 is sized to permit easy passage of the tubular portion 30 therethrough. The deformable washer 24 is also disposed over the tubular portion 30. The opening 28 in the central portion of the deformable washer 24 is sized to permit the tubular portion 30 to pass through it, but not with excessive clearance therebetween. In other words, the deformable washer 24 can slide along the tubular portion 30, but the clearance between the opening 28 and the outer surface of the tubular portion 30 is maintained at a minimal dimension for reasons that will be described in greater detail below. After assembly of the clamping bar 10 and the deformable washer 24 to the tubular portion 30, the tubular portion 30 is inserted into the opening 74 of object 70 until its distal end 60 moves into contact with a rotatable target 80 as shown. The rotatable target 80 can be a gear having a plurality of gear teeth formed in its outer surface. However, for purposes of simplicity and clarity, the rotatable target 80 in Figure 5 is illustrated as a simple circular shape. In an actual application with an automobile engine, the rotatable target 80 would have one or more teeth formed in its outer surface and would be disposed to rotate about an axis, as represented by arrow R. The bolt 20 is passed through a clearance opening 18 in the clamping bar 10 and disposed into threaded association with a hole 84 that is formed in the object 70.

Figure 5 shows the arrangement of the present invention prior to tightening the bolt 20 down into the threaded hole 84 of the object 70. In the configuration

represented in Figure 5, the tubular portion 30 of the sensor can be manually pulled back away from the target 80 or reinserted to verify that the distal end 60 is in firm contact with the target 80.

5 Figure 6 shows the arrangement of Figure 5 after the bolt 20 is tightened into the threaded hole 84 in object 70. As can be seen by comparing Figures 5 and 6, Figure 6 shows the clamping bar 10 pressed downward toward the object 70 by the natural operation of the bolt 20. When the clamping bar 10 is pushed down toward the object 70, the deformable washer 24 is deformed into a generally flat shape as shown in Figure 6. The inner edge of the opening 28, which extends through the deformable washer 24
10 as illustrated in Figure 3, is pressed into the outer surface of the tubular portion 30 and rigidly attaches the deformable washer to the tubular portion 30. As the washer attaches to the tubular portion 30 in this way, it is being deformed through a combination of its contact with the circular edge of the counterbore 76 and the lower surface of the clamping bar 10. This causes the deformation of the washer 24 to raise the edge of its
15 opening 28 away from the target 80. Because of the attachment of this inner edge to the tubular portion 30, the distal end 60 of the tubular portion 30 of the sensor is also raised away from the target 80. When the deformable washer 24 is completely deformed into a flat shape, the distal end 60 is moved from its initial contact with the target 80 to a second position that defines a gap G between the distal end 60 and the target 80. If the
20 dimensions of the deformable washer 24 are properly selected in conjunction with the size of the counterbore 76 and the outer surface of the tubular portion 30, gap G can be accurately predetermined.

Figure 7 illustrates the sensor in conjunction with the clamping bar 10 and the deformable washer 24 prior to insertion of the tubular portion 30 into the opening 74 of
25 the object, as described above in conjunction with Figures 5 and 6. During the process of the present invention, the tubular portion 30 is inserted through opening 14 of the clamping bar. The opening 14 of the clamping bar is sized to permit easy passage of the tubular portion 30 therethrough. After passing the tubular portion 30 through opening 14, the tubular portion 30 is passed through the central opening 28 of the deformable
30 washer 24. The opening 28 should be sized to permit the tubular portion 30 to slide into it. However, it is also beneficial to maintain intimate contact between the portion 30 and the washer 24. In addition, it should be understood that the opening extending

through the deformable washer 24 need not be circular in shape. In some embodiments of the present invention, the inner edge of the opening 28 can have a plurality of teeth to facilitate passage of the washer over the tubular portion while also assisting in the rigid attachment of those teeth to the outer surface of the tubular portion when the washer is deformed. In addition, it should be realized that although only one bolt clearance hole 18 is shown in the clamping bar 10, two or more such clearance holes can be used in conjunction with the present invention. When the clamping bar 10 and the deformable washer 24 are associated with the tubular portion 30 as shown in Figure 7, the assembly is ready for insertion into the hole 74 formed in the object 70. Figure 8 is an exploded view which illustrates the relative positions of the object 70, the deformable washer 24, the clamping bar 10, the sensor with its tubular portion 30 and the bolt 20.

With reference to Figures 5, 6 and 8, it can be seen that the downward pressure provided by the clamping bar 10 compresses the thickness T of the deformable washer 24 between it and the object 70. This compression deforms the deformable washer into a generally flat shape and also raises the distal end 60 of the tubular portion 30 of the sensor away from the target. The magnitude of this position change, as the deformable washer 24 is compressed by the clamping bar 10, is represented by gap G . The object 70 can be geometrically determined to result in an accurately set gap between the distal end 60 of the tubular portion 30 and the target 80.

Figures 9 and 10 illustrate the way in which the deformation of the deformable washer 24 achieves the positioning of the distal end 60 at a position which results in the accurate setting of gap G between the distal end 60 and the target 80. With reference to Figure 9, it can be seen that the deformable washer 24 is disposed in contact with the edges of the counterbore 76 which is formed in the object 70. The position shown in Figure 9 represents the status of the deformable object, as illustrated in Figure 5, prior to its compression by the clamping bar 10. In Figure 9, it can be seen that the thickness T of the deformable washer 24 is selected to result in a distance G between the upper surface of the object 70 at the counterbore 76 and the bottom surface of the deformable washer 24 where the opening 28 is formed. The geometry shown in Figure 9 results in a movement of the distal end 60 of the tubular portion 30 by a distance G .

Figure 10 shows the deformable washer 24 after it has been flattened by the compression of clamping bar 10 toward the object 70 by bolt 20. The flattening of the

deformable washer 24 causes the bottom edge of the deformable member 24 at opening 28 to move upward into alignment with the upper surface of the object 70. This results in an upward movement that is generally equivalent to distance G. If the inner edge of opening 28 is in rigid contact with the outer surface of the tubular portion 30, this rigid attachment will also cause the tubular portion 30 to move upward by the same dimension G. The upward movement of the tubular portion 30 by distance G creates a gap G between the distal end 60 and the target 80 as illustrated in Figure 6. The critical dimensions necessary to achieve the functions described above include the thickness T of the deformable washer 24, the dimension G shown in Figure 9 between the bottom surface of the deformable member 24 and the upper surface of object 70 when the washer is in contact with the edges of the counterbore 76 prior to deformation. In addition, the clearance between the edge of opening 28 and the outer surface of the tubular portion 30 shown be minimal to result in virtually instantaneous attachment between the edge of opening 28 and the outer surface of the tubular portion 30 when the deformation of the deformable washer 24 begins as a result of the clamping force exerted against it by the clamping bar 10.

The present invention provides an inexpensive, but accurate, way of setting the position of a sensor with respect to its target without the need of expensive and complicated measurement and attachment techniques. Although the present invention has been specifically illustrated to show one particularly preferred embodiment, it should be understood that many other embodiments are within its scope.

CLAIMS

1. A sensor attachment apparatus, comprising:
a sensor having a generally tubular portion;
a deformable washer, said tubular portion being slideably disposable within a
5 first opening of said washer;
a clamping bar, said clamping bar having a second opening therethrough, said
second opening being shaped to slideably receive said tubular portion therein and a third
opening; and
a bolt, said third opening being shaped to receive said bolt in slideable relation
10 therein, said bolt being engageable in threaded association in a hole of an object, said
deformable washer being compressible between said clamping bar and said object, said
deformable member being compressible into rigid attachment with said tubular portion
when said bolt is tightened to compress said clamping bar against said object, said
tubular portion being axially moved from a first position to a second position as a result
15 of said washer being deformed between said clamping bar and said object.
2. The apparatus of claim 1, wherein:
said sensor is a magnetically sensitive device.
- 20 3. The apparatus of claim 1, wherein:
said object is an automobile engine.
4. The apparatus of claim 1, wherein:
said washer is a conically shaped washer.
25
5. The apparatus of claim 4, wherein:
said conically shaped washer is a Belleville washer.
6. The apparatus of claim 1, wherein:
30 said tubular portion has a generally circular cross section.
7. The apparatus of claim 1, wherein:

said tubular portion has a noncircular cross section.

8. The apparatus of claim 1, wherein:

5 said tubular portion is in contact with a rotatable object to be sensed when in
said first position and spaced apart from said rotatable object to be sensed by a
predetermined gap when in said second position.

9. The apparatus of claim 1, wherein:

10 said washer and said tubular portion are shaped to result in deformation of said
tubular portion when said washer is deformed.

10. A method of attaching a sensor to an object:

15 providing a sensor which has a tubular portion;
disposing said tubular portion through an opening formed through a clamping
bar;
disposing said tubular portion through an opening formed through a deformable
washer;
inserting said tubular portion into an opening of said object until a distal end of
said tubular portion touches a target; and
20 compressing said clamping bar to said object to deform said washer between
said object and said clamping bar, said washer being deformed to cause said distal end
of said tubular portion to move away from said target by a predetermined distance.

11. The method of claim 10, wherein:

25 said compressing step comprises the step of inserting a bolt through said
clamping bar and into said object and tightening said bolt into said object.

12. The method of claim 10, wherein:

30 said object is an automobile engine.

13. The method of claim 10, wherein:

said target is a rotatable member.

14. The method of claim 13, wherein:
said rotatable member is a gear.
- 5 15. A sensor attachment apparatus, comprising:
a sensor having a generally tubular portion;
a deformable washer, said tubular portion being slideably disposable within a
first opening of said washer;
a clamping bar, said clamping bar having a second opening therethrough, said
10 second opening being shaped to slideably receive said tubular portion therein and a third
opening; and
a bolt, said third opening being shaped to receive said bolt in slideable relation
therein, said bolt being engageable in threaded association in a hole of an object, said
deformable washer being compressible between said clamping bar and said object, said
15 deformable member being compressible into rigid attachment with said tubular portion
when said bolt is tightened to compress said clamping bar against said object, said
tubular portion being axially moved from a first position to a second position as a result
of said washer being deformed between said clamping bar and said object, said object
being an automobile engine, said tubular portion being in contact with a rotatable object
20 to be sensed when in said first position and being spaced apart from said rotatable object
to be sensed by a predetermined gap when in said second position.
16. The apparatus of claim 15, wherein:
said sensor is a magnetically sensitive device.
25
17. The apparatus of claim 1, wherein:
said washer is a conically shaped washer.
18. The apparatus of claim 17, wherein:
30 said conically shaped washer is a Belleville washer.
19. The apparatus of claim 15, wherein:

said tubular portion has a generally circular cross section.

20. The apparatus of claim 15, wherein:
said tubular portion has a noncircular cross section.

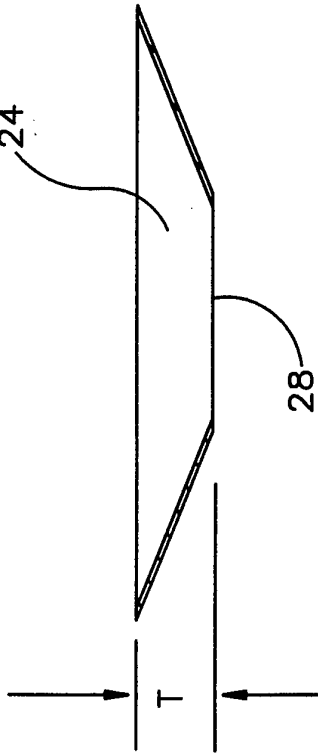

Fig. 3

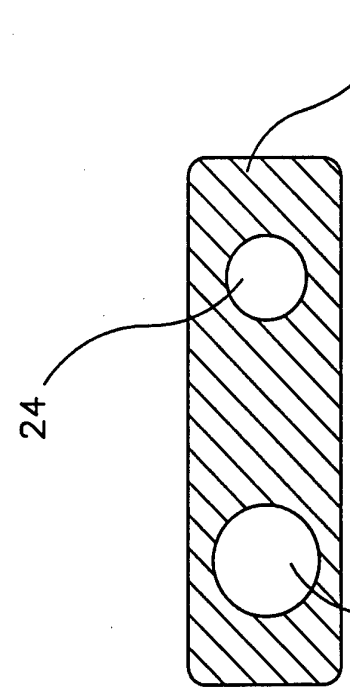

Fig. 1

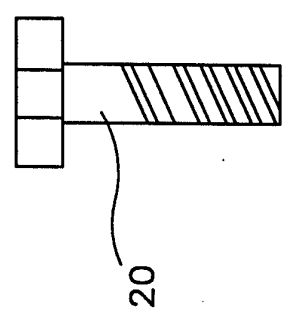

Fig. 2

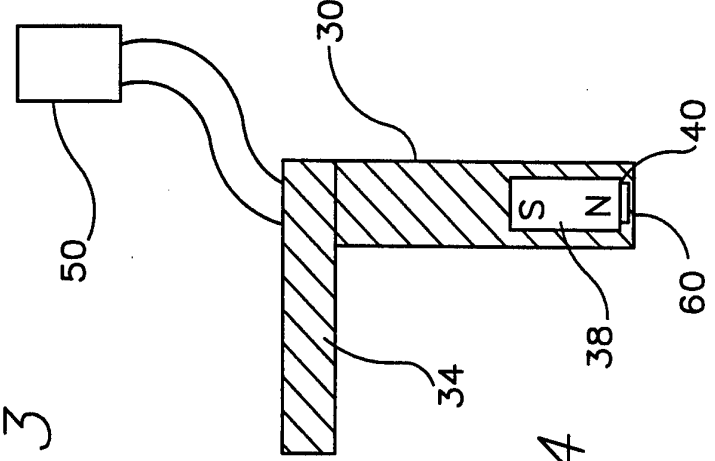

Fig. 4

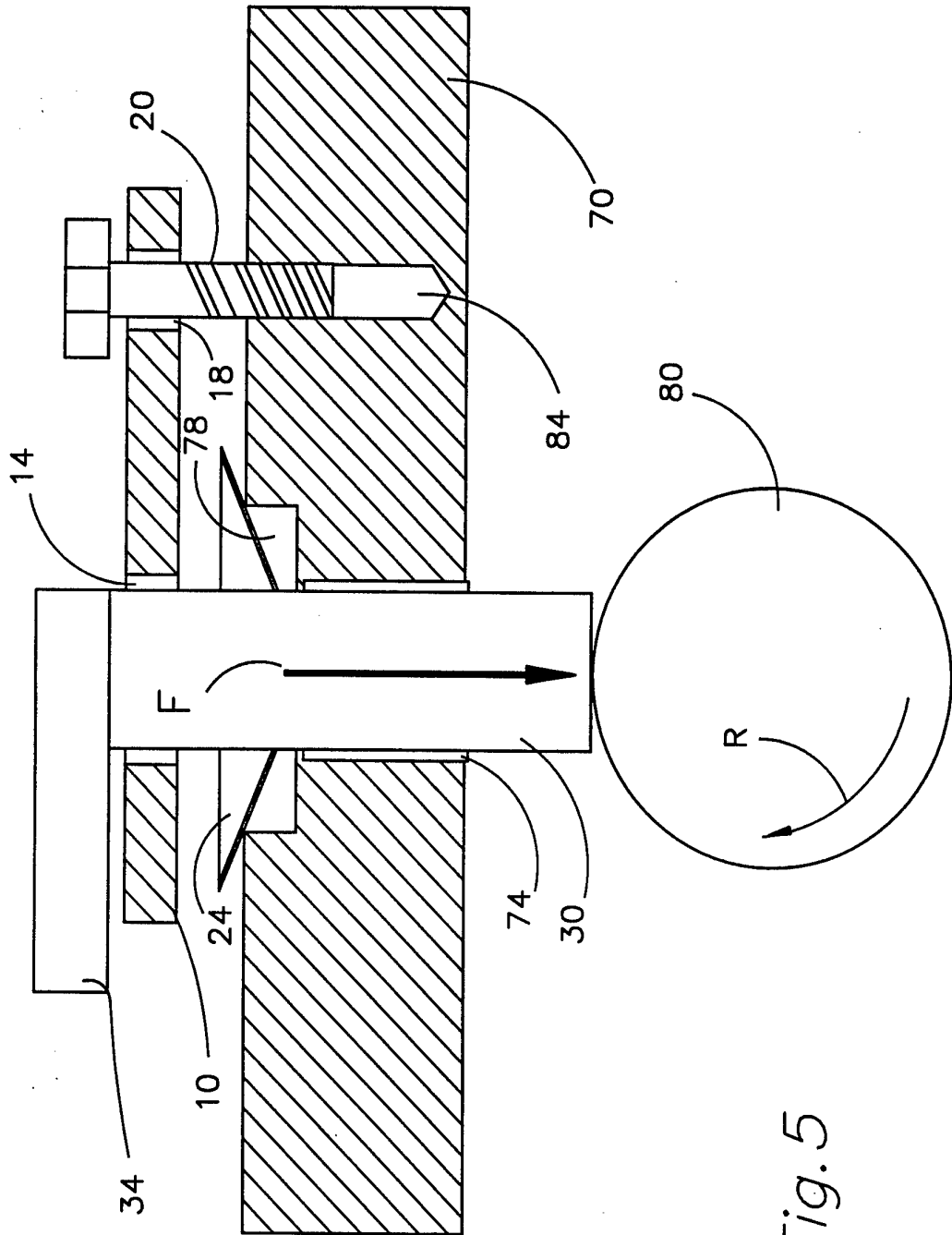

Fig. 5

3/6

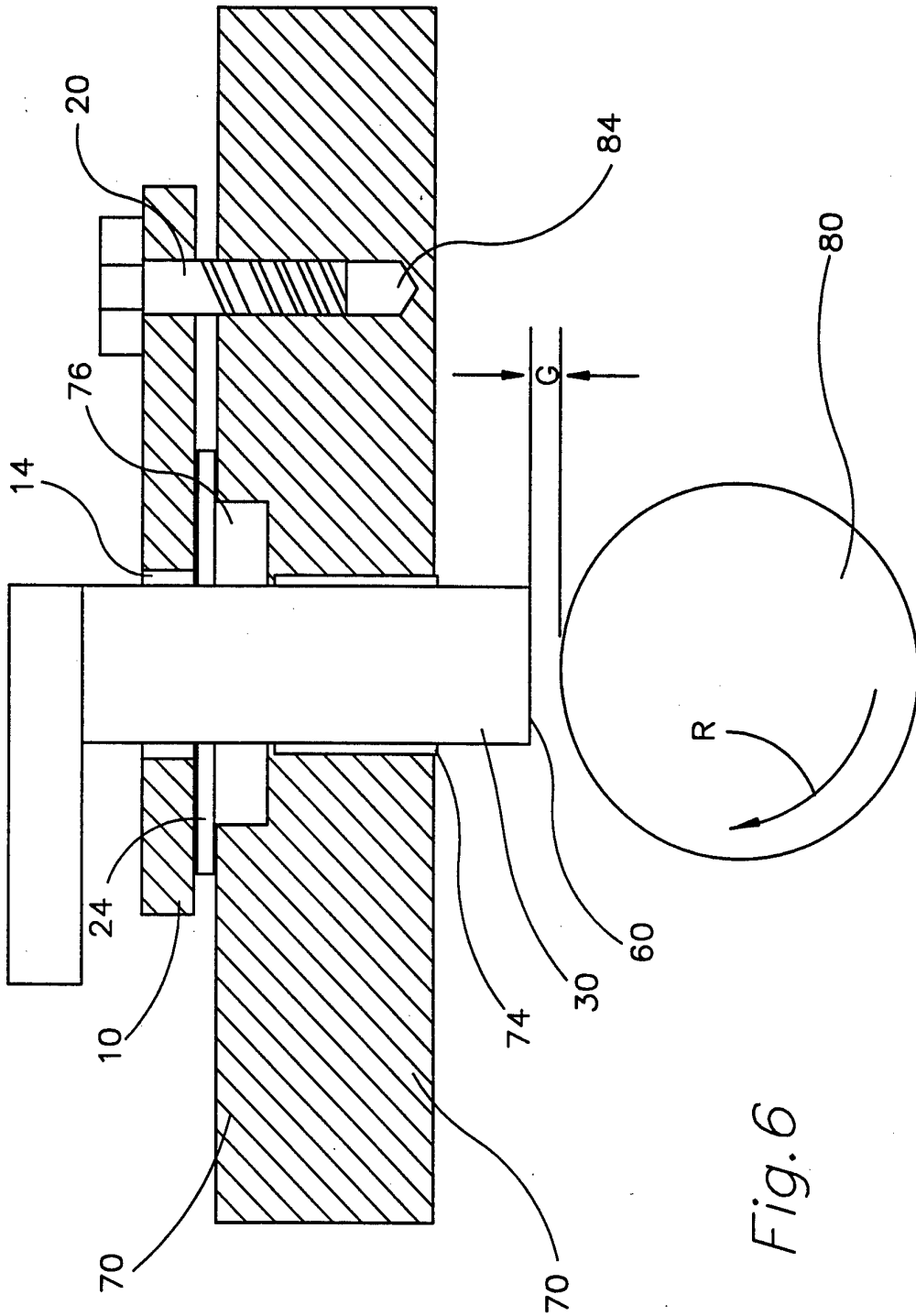

Fig. 6

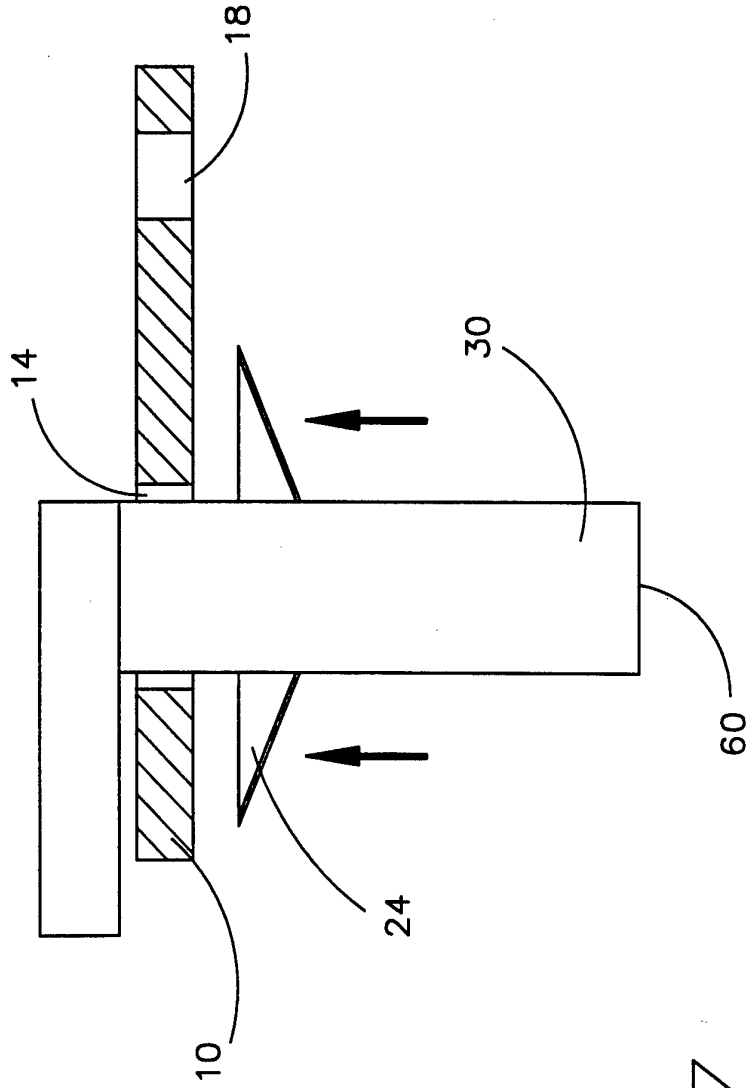

Fig. 7

5/6

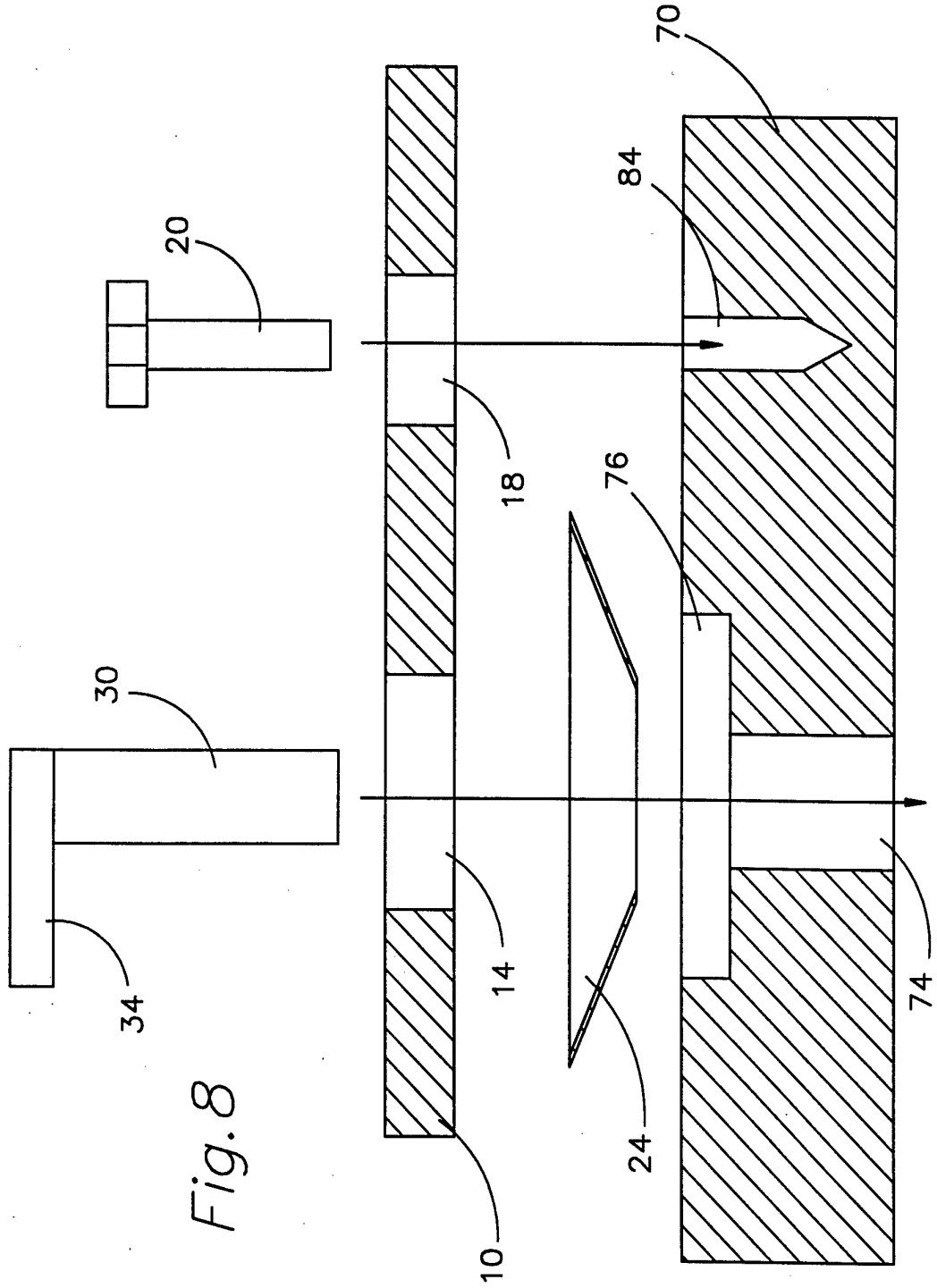
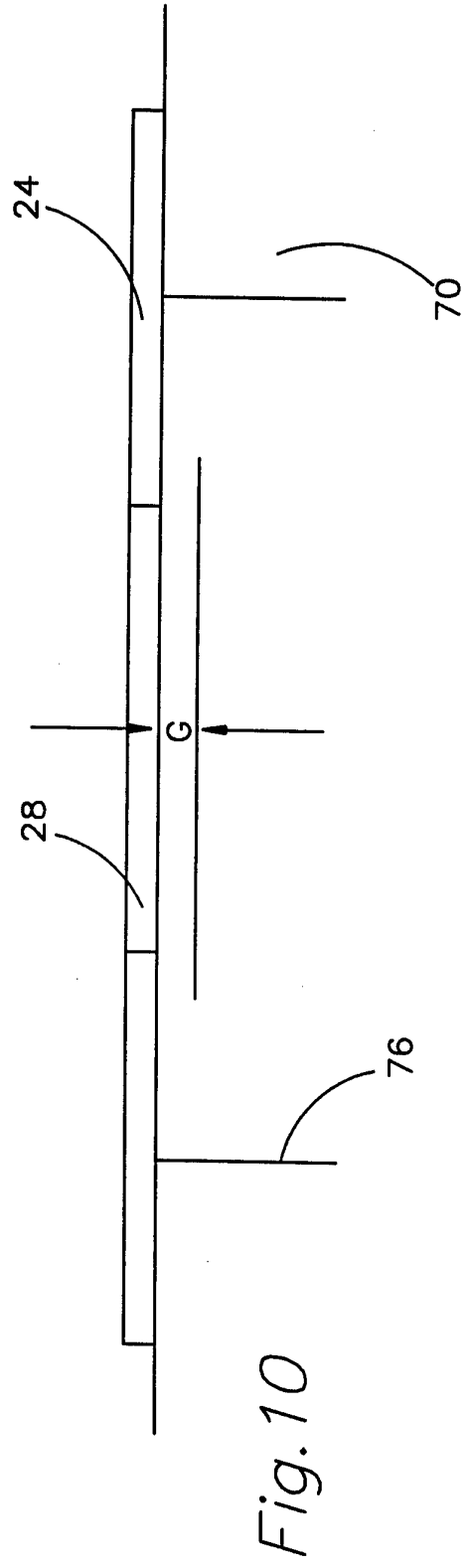
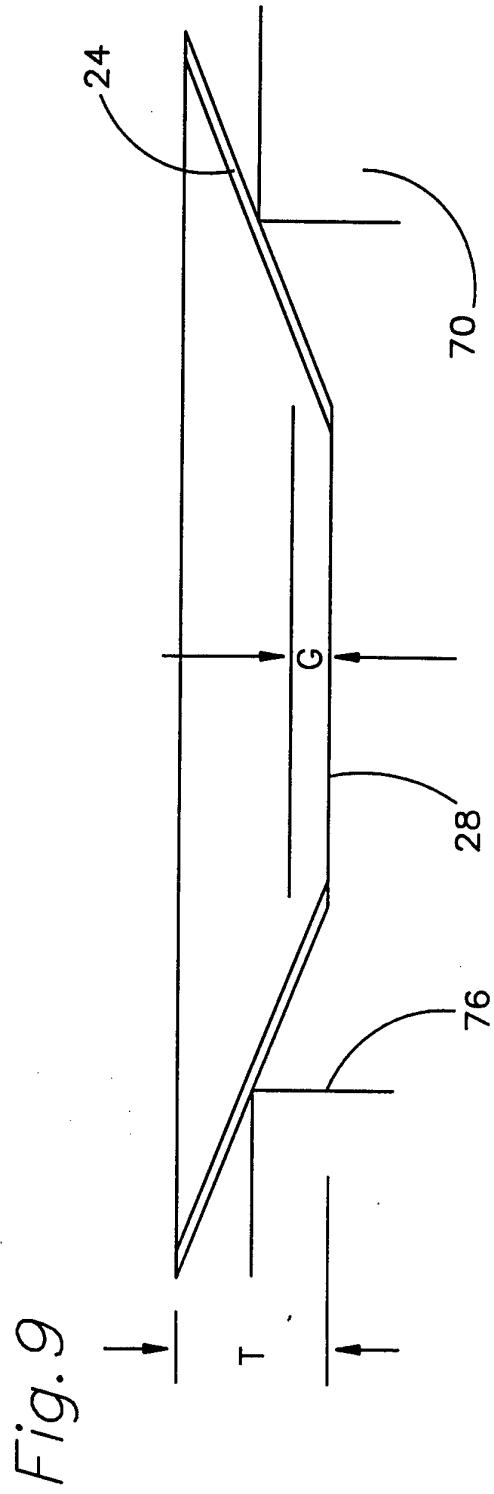

Fig. 8



INTERNATIONAL SEARCH REPORT

International Application No
PCT/US 95/05079

A. CLASSIFICATION OF SUBJECT MATTER IPC 6 G01D11/30 G01P1/00 F16B5/02		
According to International Patent Classification (IPC) or to both national classification and IPC		
B. FIELDS SEARCHED Minimum documentation searched (classification system followed by classification symbols) IPC 6 G01D G01P		
Documentation searched other than minimum documentation to the extent that such documents are included in the fields searched		
Electronic data base consulted during the international search (name of data base and, where practical, search terms used)		
C. DOCUMENTS CONSIDERED TO BE RELEVANT		
Category *	Citation of document, with indication, where appropriate, of the relevant passages	Relevant to claim No.
A	EP,A,0 183 333 (GEN MOTORS CORP) 4 June 1986 see page 1, line 26 - page 4, line 8; figures 1-9 ---	1,4,6,8, 10, 13-15, 17,19
A	FR,A,2 678 063 (JAEGER) 24 December 1992 see claims 1-3; figures 5-9 ---	1,4,6, 9-11,15, 17-19
A	US,A,4 262 527 (GROVER DONALD D ET AL) 21 April 1981 see column 2, line 62 - column 5, line 18; figures 1-4 --- -/--	1,3,6,8, 10, 12-15,19
<input checked="" type="checkbox"/> Further documents are listed in the continuation of box C.		
<input checked="" type="checkbox"/> Patent family members are listed in annex.		
* Special categories of cited documents :		
"A" document defining the general state of the art which is not considered to be of particular relevance "E" earlier document but published on or after the international filing date "L" document which may throw doubts on priority claim(s) or which is cited to establish the publication date of another citation or other special reason (as specified) "O" document referring to an oral disclosure, use, exhibition or other means "P" document published prior to the international filing date but later than the priority date claimed "T" later document published after the international filing date or priority date and not in conflict with the application but cited to understand the principle or theory underlying the invention "X" document of particular relevance; the claimed invention cannot be considered novel or cannot be considered to involve an inventive step when the document is taken alone "Y" document of particular relevance; the claimed invention cannot be considered to involve an inventive step when the document is combined with one or more other such documents, such combination being obvious to a person skilled in the art. "&" document member of the same patent family		
Date of the actual completion of the international search 16 August 1995		Date of mailing of the international search report 29.08.95
Name and mailing address of the ISA European Patent Office, P.B. 5818 Patentlaan 2 NL - 2280 HV Rijswijk Tel. (+ 31-70) 340-2040, Tx. 31 651 epo nl, Fax: (+ 31-70) 340-3016		Authorized officer Chapple, I

INTERNATIONAL SEARCH REPORT

Intern al Application No
PCT/US 95/05079

C.(Continuation) DOCUMENTS CONSIDERED TO BE RELEVANT

Category *	Citation of document, with indication, where appropriate, of the relevant passages	Relevant to claim No.
A	EP,A,0 484 242 (ROULEMENTS SOC NOUVELLE) 6 May 1992 see column 2, line 45 - column 3, line 45; figures 1-4 -----	1,2,4,5, 10,13, 15-18

INTERNATIONAL SEARCH REPORT

Information on patent family members

International Application No

PCT/US 95/05079

Patent document cited in search report	Publication date	Patent family member(s)	Publication date
EP-A-0183333	04-06-86	US-A- 4612501	16-09-86
		AU-B- 568217	17-12-87
		AU-A- 4423885	30-01-86
		CA-A- 1237506	31-05-88
		JP-B- 4022472	17-04-92
		JP-A- 61041969	28-02-86

FR-A-2678063	24-12-92	NONE	

US-A-4262527	21-04-81	NONE	

EP-A-0484242	06-05-92	US-A- 5157329	20-10-92
		DE-D- 69101367	14-04-94
		DE-T- 69101367	08-09-94
		ES-T- 2050517	16-05-94
		FR-A- 2668606	30-04-92
		JP-A- 4262966	18-09-92
