

(19) World Intellectual Property Organization
International Bureau



(43) International Publication Date
14 June 2007 (14.06.2007)

PCT

(10) International Publication Number
WO 2007/067705 A2

- (51) International Patent Classification: Not classified
- (21) International Application Number: PCT/US2006/046755
- (22) International Filing Date: 7 December 2006 (07.12.2006)
- (25) Filing Language: English
- (26) Publication Language: English
- (30) Priority Data: 60/748,638 8 December 2005 (08.12.2005) US
- (71) Applicant: GRAPHIC PACKAGING INTERNATIONAL, INC. [US/US]; 814 Livingston Court, Marietta, GA 30067 (US).
- (72) Inventor: FITZWATER, Kelly, R.; 25 Kendall Street, Lakewood, CO 80226 (US).
- (74) Agents: ISAF, Louis, T. et al.; WOMBLE CARLYLE SANDRIDGE & RICE, PLLC, P.O. Box 7037, Atlanta, GA 30357-0037 (US).
- (81) Designated States (unless otherwise indicated, for every kind of national protection available): AE, AG, AL, AM, AT, AU, AZ, BA, BB, BG, BR, BW, BY, BZ, CA, CH, CN, CO, CR, CU, CZ, DE, DK, DM, DZ, EC, EE, EG, ES, FI, GB, GD, GE, GH, GM, GT, HN, HR, HU, ID, IL, IN, IS, JP, KE, KG, KM, KN, KP, KR, KZ, LA, LC, LK, LR, LS, LT, LU, LV, LY, MA, MD, MG, MK, MN, MW, MX, MY, MZ, NA, NG, NI, NO, NZ, OM, PG, PH, PL, PT, RO, RS, RU, SC, SD, SE, SG, SK, SL, SM, SV, SY, TJ, TM, TN, TR, TT, TZ, UA, UG, US, UZ, VC, VN, ZA, ZM, ZW.
- (84) Designated States (unless otherwise indicated, for every kind of regional protection available): ARIPO (BW, GH, GM, KE, LS, MW, MZ, NA, SD, SL, SZ, TZ, UG, ZM, ZW), Eurasian (AM, AZ, BY, KG, KZ, MD, RU, TJ, TM), European (AT, BE, BG, CH, CY, CZ, DE, DK, EE, ES, FI, FR, GB, GR, HU, IE, IS, IT, LT, LU, LV, MC, NL, PL, PT, RO, SE, SI, SK, TR), OAPI (BF, BJ, CF, CG, CI, CM, GA, GN, GQ, GW, ML, MR, NE, SN, TD, TG).
- Published:**
— without international search report and to be republished upon receipt of that report
- For two-letter codes and other abbreviations, refer to the "Guidance Notes on Codes and Abbreviations" appearing at the beginning of each regular issue of the PCT Gazette.



WO 2007/067705 A2

(54) Title: PACKAGE WITH REMOVABLE PORTION

(57) Abstract: Various blanks are provided for forming sleeves, containers, and other constructs for heating, browning, and/or crisping of a food item in a microwave oven, and for holding and/or transporting the food item after heating. The various blanks, sleeves, containers, and other constructs include a removable portion defined by one or more lines of disruption that enable the removable portion to be separated from the remainder of the blank, sleeve, container, or other construct.

PACKAGE WITH REMOVABLE PORTION

CROSS-REFERENCE TO RELATED APPLICATIONS

This application claims the benefit of U.S. Provisional Application No.
5 60/748,638, filed December 8, 2005, which is incorporated by reference herein
it its entirety.

TECHNICAL FIELD

The present invention relates to various blanks, constructs, and methods
10 for heating, browning, and/or crisping a food item, and particularly relates to
various blanks, constructs, and methods for heating, browning, and/or crisping
a food item in a microwave oven.

BACKGROUND

15 There is a need for a package or other construct that facilitates
transportation and consumption of a food item therein. There further is a need
for such a package or other construct that enhances browning and crisping of a
food item in a microwave oven.

20 SUMMARY

The present invention generally is directed to various blanks and
sleeves, pouches, packages, and other constructs (collectively "constructs")
formed therefrom. The various constructs formed from the blanks include one
or more features that allow a consumer to access various portions of the food
25 item therein as the food item is consumed. Additionally, any of the constructs
of the invention may include features that enhance the browning and crisping
of the food item heated therein.

Numerous blanks are contemplated by the invention. Each blank
generally comprises a plurality of adjoining panels, each panel having a first

dimension extending in a first direction and a second dimension extending in a second direction, where the first direction is substantially perpendicular to the second direction. The various blanks typically include a pair of opposed surfaces. A microwave energy interactive element may overlie at least a portion of at least one of the opposed surfaces. The microwave energy interactive element may comprise a susceptor, a foil, a segmented foil, or any combination thereof.

Each of the various blanks includes a removable portion defined at least partially by a line of disruption. In one aspect, the removable portion is defined at least partially by a tear line extending in the second direction at least partially across at least one of the adjoined panels. In one variation, the removable portion is a first removable portion, the tear line is a first tear line, the blank further comprises a second removable portion defined at least partially by a second tear line extending in the second direction at least partially across the blank, and the first tear line is substantially parallel to the second tear line.

In another aspect, the removable portion is defined at least partially by an oblique tear line and a transverse tear line extending in the second direction at least partially across at least one of the adjoined panels. In one variation, the removable portion includes a tab and the oblique tear line extends substantially between the tab and the transverse tear line.

In still another aspect, the removable portion is defined at least partially by an oblique tear line in the main panel and a transverse tear line extending in the second direction substantially across the main panel. The oblique tear line extends from a tab proximate a peripheral edge extending in the second direction. In one variation, the oblique tear line extends substantially between the tab and the transverse tear line. In another variation, the tab is positioned adjacent to a cutout in the blank.

In another aspect, the removable portion is defined by a tear line extending obliquely across at least a portion of least one of the adjoined panels. In one variation, the removable portion is a first removable portion of a plurality of removable portions, the tear line is a first tear line of a plurality of
5 tear lines that define the plurality of removable portions, and each of the plurality of tear lines extend obliquely across at least a portion of at least one of the plurality of panels.

In a further aspect, the removable portion is defined by a tear line that extends in the first direction and adjoins a first pair of adjacent panels of the
10 plurality of adjoined panels. In one variation, the tear line is a first tear line, and the removable portion is defined further by a second tear line that extends in the first direction and adjoins a second pair of adjacent panels.

In a yet further aspect, the removable portion is defined by a line of disruption initiating and terminating proximate a peripheral edge extending in
15 the second direction along the blank. The line of disruption may comprise a cut line, a score line, a kiss cut line, a perforated line, a zigzag cut line, a zipper cut line, or any combination thereof.

Any of the various blanks may be formed into a sleeve for heating, browning, and/or crisping a food item in a microwave oven, where the sleeve
20 includes a removable portion comprising the removable portion of the blank. The sleeve may comprise a first main panel and a second main panel in an opposed configuration, and a first minor panel and a second minor panel in an opposed configuration. The first main panel, the second main panel, the first minor panel, and the second minor panel are joined to the first main panel and
25 the second main panel along respective fold lines to define at least partially an interior surface. A microwave energy interactive element overlies at least a portion of the interior surface. The microwave energy interactive element may comprise a susceptor, a foil, a segmented foil, or any combination thereof.

The sleeve may include a removable portion comprising at least a portion of at least one of the first main panel, the second main panel, the first minor panel, and the second minor panel. In one aspect, the removable portion is defined at least partially by a line of disruption extending in the second direction across at least a portion of at least one of the first main panel, the second main panel, the first minor panel, and the second minor panel. In another aspect, the removable portion is defined at least partially by an oblique tear line at least partially lying within the first main panel and a transverse tear line extending in the second direction across at least a portion of the first main panel. In yet another aspect, the removable portion is defined at least partially by a line of disruption extending obliquely across at least one of the first main panel, the second main panel, the first minor panel, and the second minor panel. In still another aspect, the removable portion is defined by at least one tear line that extends in the first direction and adjoins at least one of the first main panel and the second main panel to at least one of the first minor panel and the second minor panel. In a still further aspect, the removable portion is defined by a line of disruption initiating and terminating proximate the first end of at least one of the adjoined panels.

If desired, the sleeve may be transformed into a container in which the food item can be positioned in an upright configuration for transportation and/or consumption. The container generally may include a pair of opposed main panels, a pair of opposed minor panels joined to the main panels along respective fold lines, and a pair of end panels collectively defining an interior space. The end panels may be folded toward the interior space in a superposed configuration. The container may be positioned in an upright configuration with the food item being supported by the end panels.

The container includes one or more removable portions that allow a user to reduce the size of, or alter the shape of, the container, thereby gaining better access to the food item. In one aspect, the removable is portion defined at least

partially by a line of disruption extending in the second direction across at least a portion of at least one of the first main panel, the second main panel, the first minor panel, and the second minor panel.

5 In another aspect, the removable portion is defined at least partially by an oblique tear line and a transverse tear line extending in the second direction at least partially across at least one of the adjoining panels. In one variation, the removable portion comprises a tab and the oblique tear line extends substantially between the tab and the transverse tear line. In another variation, the container includes a cutout disposed between the first main panel and the
10 second main panel. In another variation, the container includes a microwave energy interactive element overlying at least a portion of at least one of the first main panel, the second main panel, the first minor panel, and the second minor panel.

In yet another aspect, the removable portion is defined at least partially
15 by a line of disruption extending obliquely across at least one of the first main panel, the second main panel, the first minor panel, and the second minor panel. In still another aspect, the removable portion is defined by at least one tear line that extends in the first direction and adjoins at least one of the first main panel and the second main panel to at least one of the first minor panel
20 and the second minor panel. In a further aspect, the removable portion is defined at least partially by a line of disruption initiating and terminating proximate the first end of at least one of the adjoining panels.

Other features, aspects, and embodiments will be apparent from the following description and accompanying figures.

25

BRIEF DESCRIPTION OF THE DRAWINGS

The description refers to the accompanying drawings, some of which are schematic, in which like reference characters refer to like parts throughout the several views, and in which:

FIG. 1A depicts an exemplary blank according to various aspects of the present invention;

FIGS. 1B and **1C** illustrate the blank of **FIG. 1A** formed into a sleeve with two open ends, according to various aspects of the present invention;

5 **FIGS. 1D-1F** illustrate the blank of **FIG. 1A** formed into a container for carrying a food item therein, according to various aspects of the present invention;

FIG. 2A depicts another exemplary blank according to various aspects of the present invention;

10 **FIG. 2B** illustrates the blank of **FIG. 2A** formed into a sleeve with two open ends, according to various aspects of the present invention;

FIG. 2C illustrates the blank of **FIG. 2A** formed into a container for supporting a food item therein, according to various aspects of the present invention;

15 **FIG. 3A** depicts yet another exemplary blank according to various aspects of the present invention;

FIG. 3B illustrates the blank of **FIG. 3A** formed into a sleeve with two open ends, according to various aspects of the present invention;

20 **FIGS. 3C-3F** illustrate the blank of **FIG. 3A** formed into a container for carrying a food item therein, according to various aspects of the present invention;

FIG. 4A depicts still another exemplary blank according to various aspects of the present invention;

25 **FIG. 4B** illustrates the blank of **FIG. 4A** formed into a sleeve with two open ends, according to various aspects of the present invention;

FIG. 4C illustrates the blank of **FIG. 4A** formed into a container for carrying a food item therein, according to various aspects of the present invention;

FIG. 5A depicts yet another exemplary blank according to various aspects of the present invention;

FIG. 5B illustrates the blank of **FIG. 5A** formed into a container for carrying a food item therein, according to various aspects of the present invention;

FIG. 6A depicts still another exemplary blank according to various aspects of the present invention;

FIG. 6B illustrates the blank of **FIG. 6A** formed into a sleeve with two open ends, according to various aspects of the present invention;

FIGS. 6C and **6D** illustrate the blank of **FIG. 6A** formed into a container for carrying a food item therein, according to various aspects of the present invention

FIG. 7A depicts another exemplary blank according to various aspects of the present invention;

FIG. 7B illustrates the blank of **FIG. 7A** formed into a container for carrying a food item therein, according to various aspects of the present invention;

FIG. 8A depicts an exemplary blank according to various aspects of the present invention;

FIGS. 8B and **8C** illustrate the blank of **FIG. 8A** formed into a sleeve with two open ends, according to various aspects of the present invention;

FIGS. 8D-8G illustrate the blank of **FIG. 8A** formed into a container for carrying a food item therein, according to various aspects of the present invention;

FIG. 9A depicts an exemplary blank according to various aspects of the present invention;

FIG. 9B illustrates the blank of **FIG. 9A** formed into a sleeve with two open ends, according to various aspects of the present invention;

FIGS. 9C-9E illustrate the blank of **FIG. 9A** formed into a container for carrying a food item therein, according to various aspects of the present invention;

FIG. 10A depicts an exemplary blank according to various aspects of the present invention;

FIG. 10B illustrates the blank of **FIG. 10A** formed into a sleeve with two open ends, according to various aspects of the present invention;

FIGS. 10C-10E illustrate the blank of **FIG. 10A** formed into a container for carrying a food item therein, according to various aspects of the present invention;

FIG. 11A depicts another exemplary blank according to various aspects of the present invention; and

FIG. 11B depicts the blank of **FIG. 11A** formed into a sleeve with two open ends, according to various aspects of the present invention.

DESCRIPTION

The present invention may be illustrated further by referring to the figures. For purposes of simplicity, like numerals may be used to describe like features. It will be understood that where a plurality of similar features are depicted, not all of such features necessarily are labeled on each figure. It also will be understood that various components used to form the blanks and constructs of the present invention may be interchanged. Thus, while only certain combinations are illustrated herein, numerous other combinations and configurations are contemplated hereby.

FIG. 1A depicts an exemplary blank **100** according to various aspects of the present invention. The blank **100** generally includes a plurality of adjoined panels. In this and other aspects of the invention discussed herein and/or contemplated hereby, each of the various panels and blanks generally have a first dimension, for example, a length, extending in a first direction, for

example, a longitudinal direction, **D1**, and a second dimension, for example, a width, extending in a second direction, for example, a transverse direction, **D2**. It will be understood that such designations are made only for convenience and do not necessarily refer to or limit the manner in which the blank is
5 manufactured or erected into a construct.

The blank **100** generally includes a main panel **102**, a first major panel **104a**, a second major panel **104b**, a first minor panel **106**, and a second minor panel **108**. The first minor panel **106** is joined to the first major panel **104a** along a longitudinal fold line **110**. The main panel **102** is joined to the first
10 minor panel **106** along a longitudinal fold line **112**. The second minor panel **108** is joined to the main panel **102** along a longitudinal fold line **114**. The second major panel **104b** is joined to the second minor panel **108** along a longitudinal fold line **116**. In this example, minor panels **106** and **108** are substantially equal in length, **L1**. Additionally, fold lines **110**, **112**, **114**, and
15 **116** are substantially parallel and substantially equal in length, **L1**. However, other lengths and configurations are contemplated hereby.

The blank **100** includes partial end panels **118a** and **118b** respectively joined to major panels **104a** and **104b** along respective curved fold line segments **120a** and **120b**. Each of the partial end panels **118a** and **118b**
20 respectively optionally include a partial cutout **122a** and **122b**, which may or may not be similar or identical in shape and size.

The blank **100** also includes an end panel **124** joined to the main panel **102** along a substantially arcuate fold line **126**. In this example, the end panel **124** is substantially lentiform in shape, generally resembling a biconvex lens
25 including two opposed substantially parallel edges **128**, a first, inner arcuate edge defined by fold line **126**, and a second, outer arcuate edge **130**. However, the end panel **124** may have any suitable shape, for example, square, rectangle, oval, or any other regular or irregular shape.

The first minor panel **106** and the second minor panel **108** each include respective longitudinal fold lines **132** and **134** substantially centrally disposed and extending along the length **L1** thereof. Optionally, one or both of the first minor panel **106** and the second minor panel **108** include respective apertures **136** and **138**. In the example shown in **FIG. 1A**, aperture **136** is substantially circular in shape and extends substantially between fold lines **110** and **112**. Likewise, aperture **138** is substantially circular in shape and extends substantially between fold lines **114** and **116**. However, it will be understood that in this and other aspects of the invention described herein and contemplated hereby, the number, shape, size, and positioning of such apertures may vary for a particular application depending on type of construct being formed from the blank, the food item to be heated therein or thereon, the desired degree of browning and/or crisping, whether direct exposure to microwave energy is needed or desired to attain uniform heating of the food item, the need for regulating the change in temperature of the food item through direct heating, and whether and to what extent there is a need for venting.

Still viewing **FIG. 1A**, the blank **100** includes a first removable portion **140** and a second removable portion **142** extending in the transverse direction. Each removable portion **140** and **142** includes at least a portion of each of panels **102**, **104a**, **104b**, **106**, and **108**. The first removable portion **140** is joined to the second removable portion **142** along a transverse tear line **144**. The second removable portion **142** is joined to the remainder of panels **102**, **104a**, and **104b** along a transverse tear line **146** that, in this example, is interrupted by apertures **136** and **138**. It will be understood that while the exemplary blank **100** of **FIG. 1A** includes two removable portions **140** and **142**, any number of such removable portions and any configuration of such removable portions may be used as desired. Additionally, it will be understood that in this and other aspects of the invention, any type of tear line or other line

of disruption may be used to define the removable portion. For example, the line of disruption may include a score line, a cut line, a perforated line, kiss cut line, zigzag cut line, a zipper cut line, any other suitable line of disruption, or any combination thereof. Further, in this example, tear line **144** is shown as
5 being substantially parallel to tear line **146**. However, other configurations of tear lines are contemplated hereby.

The first removable portion **140** includes an extension or tab **148** that partially defines a peripheral edge **150** extending in the longitudinal direction. In this example, the tab **148** is substantially arcuate in shape. However, it will
10 be understood that the extension may have any shape as needed or desired. For example, the extension may be oval, rectangular, square, diamond-shaped, trapezoidal, polygonal, or any other regular or irregular shape. Tear line **152a** extends from a first end **154a** of tab **148** towards, and may abut, edge **156**. Tear line **152b** extends from a second end **154b** of tab **148** in a direction
15 towards, and may abut, tear line **144**. In this example, tear lines **152a** and **152b** are positioned relative to tab **148** such that the combination of tear line **152a**, tab **148**, and tear line **152b** is substantially arcuate in shape. However, it will be understood that such tear lines may have any suitable shape and may or may not correspond to or extend the shape of the tab. Thus, for example, although
20 the tab **148** is substantially arcuate in shape, the tear line segments **152a** and **152b** may be parallel lines, zigzags, or any other configuration. Tear lines **152a** and **152b** cooperate with tab **148** to facilitate removal of the first removable portion **140**, as will be described below.

The first removable portion **140** includes a cutout **158** that partially
25 defines a peripheral edge **160** extending in the longitudinal direction. In this example, the cutout **158** also is substantially semi-circular or arcuate in shape. The cutout **158** may have any suitable shape as needed or desired, and may or may not correspond to the shape or dimensions of tab **148**. The first removable portion **140** further includes a gluing area **162** adjacent the cutout **158** and

defined by a perimeter 164. In the blank 100 shown in FIG. 1A, the gluing area 162 is shaped somewhat like an arch or bridge. However, it will be understood that the gluing area may have any suitable shape as needed or desired.

5 Similarly, the second removable portion 142 includes a tab 166 that partially defines peripheral edge 150 and a cutout 168 that partially defines peripheral edge 160. Tear line 170a extends from a first end 172a of tab 166 in a direction towards, and may abut, transverse tear line 144. Tear line 170b extends from a second end 172b of tab 166 in a direction towards, and may
10 abut, transverse tear line 146. The second removable portion 142 further includes a gluing area 174 adjacent the cutout 168 and defined by a perimeter 176. As discussed above, the tab 166, cutout 168, tear lines 170a and 170b, and gluing area 174 may have any shape as needed or desired including, but not limited to, those described above.

15 Numerous materials may be suitable for use in forming the various blanks and constructs of the invention, provided that the materials are resistant to softening, scorching, combusting, or degrading at typical microwave oven heating temperatures, for example, at from about 250°F to about 425°F. The particular materials used may include microwave energy interactive materials
20 and microwave energy transparent or inactive materials.

For example, any of the various blanks or constructs of the present invention may include one or more features that alter the effect of microwave energy during the heating or cooking of the food item. For example, the blank or construct may be formed at least partially from one or more microwave
25 energy interactive elements (hereinafter sometimes referred to as “microwave interactive elements”) that promote browning and/or crisping of a particular area of the food item, shield a particular area of the food item from microwave energy to prevent overcooking thereof, or transmit microwave energy toward or away from a particular area of the food item. Each microwave interactive

element comprises one or more microwave energy interactive materials or segments arranged in a particular configuration to absorb microwave energy, transmit microwave energy, reflect microwave energy, or direct microwave energy, as needed or desired for a particular microwave heating construct and food item.

The microwave interactive element may be supported on a microwave inactive or transparent substrate for ease of handling and/or to prevent contact between the microwave interactive material and the food item. As a matter of convenience and not limitation, and although it is understood that a microwave interactive element supported on a microwave transparent substrate includes both microwave interactive and microwave inactive elements or components, such constructs are referred to herein as "microwave interactive webs".

The microwave energy interactive material may be an electroconductive or semiconductive material, for example, a metal or a metal alloy provided as a metal foil; a vacuum deposited metal or metal alloy; or a metallic ink, an organic ink, an inorganic ink, a metallic paste, an organic paste, an inorganic paste, or any combination thereof. Examples of metals and metal alloys that may be suitable for use with the present invention include, but are not limited to, aluminum, chromium, copper, inconel alloys (nickel-chromium-molybdenum alloy with niobium), iron, magnesium, nickel, stainless steel, tin, titanium, tungsten, and any combination or alloy thereof.

Alternatively, the microwave energy interactive material may comprise a metal oxide. Examples of metal oxides that may be suitable for use with the present invention include, but are not limited to, oxides of aluminum, iron, and tin, used in conjunction with an electrically conductive material where needed. Another example of a metal oxide that may be suitable for use with the present invention is indium tin oxide (ITO). ITO can be used as a microwave energy interactive material to provide a heating effect, a shielding effect, a browning and/or crisping effect, or a combination thereof. For example, to form a

susceptor, ITO may be sputtered onto a clear polymer film. The sputtering process typically occurs at a lower temperature than the evaporative deposition process used for metal deposition. ITO has a more uniform crystal structure and, therefore, is clear at most coating thicknesses. Additionally, ITO can be used for either heating or field management effects. ITO also may have fewer defects than metals, thereby making thick coatings of ITO more suitable for field management than thick coatings of metals, such as aluminum.

Alternatively, the microwave energy interactive material may comprise a suitable electroconductive, semiconductive, or non-conductive artificial dielectric or ferroelectric. Artificial dielectrics comprise conductive, subdivided material in a polymeric or other suitable matrix or binder, and may include flakes of an electroconductive metal, for example, aluminum.

In one example, the microwave interactive element may comprise a thin layer of microwave interactive material, for example, a susceptor, that tends to absorb microwave energy and generate heat at the interface with a food item in intimate or proximate contact therewith. Such elements often are used to promote browning and/or crisping of the surface of a food item (sometimes referred to as a "browning and/or crisping element"). When supported on a film or other substrate, such an element may be referred to as a "susceptor film" or, simply, "susceptor". Where the substrate is a blank, carton, or other construct including a plurality of panels, a susceptor may overlie all or a portion of one or more of the panels, and may form at least a portion of the surface proximate the food item. By way of example, and not limitation, a susceptor **M** may overlie at least a portion of blank **100** (hidden from view in **FIG. 1A**, which illustrates the side of the blank that forms the exterior surface of the construct), and may form at least a portion of the interior surface of the construct **178** formed therefrom, as depicted in **FIGS. 1B, 1C, and 1F**. However, other microwave energy interactive elements, such as those described herein, are contemplated for use with the invention.

For example, the microwave interactive element may comprise a foil having a thickness sufficient to shield one or more selected portions of the food item from microwave energy (sometimes referred to as a "shielding element"). Such shielding elements may be used where the food item is prone to scorching or drying out during heating. The shielding element may be formed from various materials and may have various configurations, depending on the particular application for which the shielding element is used. Typically, the shielding element is formed from a conductive, reflective metal or metal alloy, for example, aluminum, copper, or stainless steel. The shielding element generally may have a thickness of from about 0.000285 inches to about 0.05 inches. In one aspect, the shielding element has a thickness of from about 0.0003 inches to about 0.03 inches. In another aspect, the shielding element has a thickness of from about 0.00035 inches to about 0.020 inches, for example, 0.016 inches.

As still another example, the microwave interactive element may comprise a segmented foil, such as, but not limited to, those described in U.S. Patent Nos. 6,204,492, 6,433,322, 6,552,315, and 6,677,563, each of which is incorporated by reference in its entirety. Although segmented foils are not continuous, appropriately spaced groupings of such segments often act as a transmitting element to direct microwave energy to specific areas of the food item. Such foils also may be used in combination with browning and/or crisping elements, for example, susceptors.

Any of the numerous microwave interactive elements described herein or contemplated hereby may be substantially continuous, that is, without substantial breaks or interruptions, or may be discontinuous, for example, by including one or more breaks or apertures that transmit microwave energy therethrough. The breaks or apertures may be sized and/or positioned to heat particular areas of the food item selectively. As stated previously, the number, shape, size, and positioning of such breaks or apertures may vary for a

particular application depending on type of construct being formed, the food item to be heated therein or thereon, the desired degree of shielding, browning, and/or crisping, whether direct exposure to microwave energy is needed or desired to attain uniform heating of the food item, the need for regulating the change in temperature of the food item through direct heating, whether and to what extent there is a need for venting, and numerous other factors.

It will be understood that the aperture may be a physical aperture or void in the material used to form the construct, or may be a non-physical "aperture". A non-physical aperture may be a portion of the construct that is microwave energy inactive by deactivation or otherwise, or one that is otherwise transparent to microwave energy. Thus, for example, the aperture may be a portion of the construct formed without a microwave energy interactive material or, alternatively, may be a portion of the construct formed with a microwave energy interactive material that has been deactivated. While both physical and non-physical apertures allow the food item to be heated directly by the microwave energy, a physical aperture also provides a venting function to allow steam or other vapors to be released from the food item.

It also may be beneficial to create one or more discontinuities or inactive regions to prevent overheating or charring of the construct. By way of example, and not limitation, in the construct 178 illustrated in FIG. 1C, panels 104a and 104b are overlapped to form a second main panel 104, as will be discussed below. When exposed to microwave energy, the concentration of heat generated by the overlapped panels may be sufficient to cause the underlying support, in this case, paperboard, to become scorched. As such, the overlapping portions of one or both of panels 104a and 104b may be designed to be microwave inactive, for example, by forming these areas without a microwave energy interactive material or by deactivating the microwave energy interactive material in these areas.

Further still, one or more panels, portions of panels, or portions of the construct may be designed to be microwave energy inactive to ensure that the microwave energy is focused efficiently on the areas to be browned and/or crisped, rather than being lost to portions of the food item not intended to be browned and/or crisped or to the heating environment.

As stated above, any of the above elements and numerous others contemplated hereby may be supported on a substrate. The substrate typically comprises an electrical insulator, for example, a polymer film or other polymeric material. As used herein the terms "polymer", "polymer film", and "polymeric material" include, but are not limited to, homopolymers, copolymers, such as for example, block, graft, random, and alternating copolymers, terpolymers, etc. and blends and modifications thereof. Furthermore, unless otherwise specifically limited, the term "polymer" shall include all possible geometrical configurations of the molecule. These configurations include, but are not limited to isotactic, syndiotactic, and random symmetries.

The thickness of the film typically may be from about 35 gauge to about 10 mil. In one aspect, the thickness of the film is from about 40 to about 80 gauge. In another aspect, the thickness of the film is from about 45 to about 50 gauge. In still another aspect, the thickness of the film is about 48 gauge. Examples of polymer films that may be suitable include, but are not limited to, polyolefins, polyesters, polyamides, polyimides, polysulfones, polyether ketones, cellophanes, or any combination thereof. Other non-conducting substrate materials such as paper and paper laminates, metal oxides, silicates, cellulose, or any combination thereof, also may be used.

In one example, the polymer film comprises polyethylene terephthalate (PET). Polyethylene terephthalate films are used in commercially available susceptors, for example, the QWIKWAVE[®] Focus susceptor and the MICRORITE[®] susceptor, both available from Graphic Packaging International (Marietta, Georgia). Examples of polyethylene terephthalate films that may be

suitable for use as the substrate include, but are not limited to, MELINEX[®], commercially available from DuPont Teijan Films (Hopewell, Virginia), SKYROL, commercially available from SKC, Inc. (Covington, Georgia), and BARRIALOX PET, available from Toray Films (Front Royal, VA), and QU50
5 High Barrier Coated PET, available from Toray Films (Front Royal, VA).

The polymer film may be selected to impart various properties to the microwave interactive web, for example, printability, heat resistance, or any other property. As one particular example, the polymer film may be selected to provide a water barrier, oxygen barrier, or a combination thereof. Such barrier
10 film layers may be formed from a polymer film having barrier properties or from any other barrier layer or coating as desired. Suitable polymer films may include, but are not limited to, ethylene vinyl alcohol, barrier nylon, polyvinylidene chloride, barrier fluoropolymer, nylon 6, nylon 6,6, coextruded nylon 6/EVOH/nylon 6, silicon oxide coated film, barrier polyethylene
15 terephthalate, or any combination thereof.

One example of a barrier film that may be suitable for use with the present invention is CAPRAN[®] EMBLEM 1200M nylon 6, commercially available from Honeywell International (Pottsville, Pennsylvania). Another example of a barrier film that may be suitable is CAPRAN[®] OXYSHIELD
20 OBS monoaxially oriented coextruded nylon 6/ethylene vinyl alcohol (EVOH)/nylon 6, also commercially available from Honeywell International. Yet another example of a barrier film that may be suitable for use with the present invention is DARTEK[®] N-201 nylon 6,6, commercially available from Enhance Packaging Technologies (Webster, New York). Additional examples
25 include BARRIALOX PET, available from Toray Films (Front Royal, VA) and QU50 High Barrier Coated PET, available from Toray Films (Front Royal, VA), referred to above.

Still other barrier films include silicon oxide coated films, such as those available from Sheldahl Films (Northfield, Minnesota). Thus, in one example,

a susceptor may have a structure including a film, for example, polyethylene terephthalate, with a layer of silicon oxide coated onto the film, and ITO or other material deposited over the silicon oxide. If needed or desired, additional layers or coatings may be provided to shield the individual layers from damage
5 during processing.

The barrier film may have an oxygen transmission rate (OTR) as measured using ASTM D3985 of less than about 20 cc/m²/day. In one aspect, the barrier film has an OTR of less than about 10 cc/m²/day. In another aspect, the barrier film has an OTR of less than about 1 cc/m²/day. In still another
10 aspect, the barrier film has an OTR of less than about 0.5 cc/m²/day. In yet another aspect, the barrier film has an OTR of less than about 0.1 cc/m²/day.

The barrier film may have a water vapor transmission rate (WVTR) of less than about 100 g/m²/day as measured using ASTM F1249. In one aspect, the barrier film has a water vapor transmission rate as measured using ASTM
15 F1249 of less than about 50 g/m²/day. In another aspect, the barrier film has a WVTR of less than about 15 g/m²/day. In yet another aspect, the barrier film has a WVTR of less than about 1 g/m²/day. In still another aspect, the barrier film has a WVTR of less than about 0.1 g/m²/day. In a still further aspect, the barrier film has a WVTR of less than about 0.05 g/m²/day.

20 Other non-conducting substrate materials such as metal oxides, silicates, cellulose, or any combination thereof, also may be used in accordance with the present invention.

The microwave energy interactive material may be applied to the substrate in any suitable manner, and in some instances, the microwave energy
25 interactive material is printed on, extruded onto, sputtered onto, evaporated on, or laminated to the substrate. The microwave energy interactive material may be applied to the substrate in any pattern, and using any technique, to achieve the desired heating effect of the food item. For example, the microwave energy interactive material may be provided as a continuous or discontinuous layer or

coating including circles, loops, hexagons, islands, squares, rectangles, octagons, and so forth. Examples of various patterns and methods that may be suitable for use with the present invention are provided in U.S. Patent Nos. 6,765,182; 6,717,121; 6,677,563; 6,552,315; 6,455,827; 6,433,322; 6,410,290; 5 6,251,451; 6,204,492; 6,150,646; 6,114,679; 5,800,724; 5,759,418; 5,672,407; 5,628,921; 5,519,195; 5,420,517; 5,410,135; 5,354,973; 5,340,436; 5,266,386; 5,260,537; 5,221,419; 5,213,902; 5,117,078; 5,039,364; 4,963,420; 4,936,935; 4,890,439; 4,775,771; 4,865,921; and Re. 34,683, each of which is incorporated by reference herein in its entirety. Although particular examples
10 of patterns of microwave energy interactive material are shown and described herein, it should be understood that other patterns of microwave energy interactive material are contemplated by the present invention.

The microwave interactive element or microwave interactive web may be joined to or overlie a dimensionally stable, microwave energy transparent
15 support (hereinafter referred to as “microwave transparent support”, “microwave inactive support” or “support”) to form at least a portion of the construct.

In one aspect, for example, where a rigid or semi-rigid construct is to be formed, all or a portion of the support may be formed at least partially from a
20 paperboard material, which may be cut into a blank prior to use in the construct. For example, the support may be formed from paperboard having a basis weight of from about 60 to about 330 lbs/ream, for example, from about 80 to about 140 lbs/ream. The paperboard generally may have a thickness of from about 6 to about 30 mils, for example, from about 12 to about 28 mils. In
25 one particular example, the paperboard has a thickness of about 12 mils. Any suitable paperboard may be used, for example, a solid bleached or solid unbleached sulfate board, such as SUS® board, commercially available from Graphic Packaging International.

In another aspect, where a more flexible construct is to be formed, the support may comprise a paper or paper-based material generally having a basis weight of from about 15 to about 60 lbs/ream, for example, from about 20 to about 40 lbs/ream. In one particular example, the paper has a basis weight of
5 about 25 lbs/ream.

Optionally, one or more portions or sides of the various blanks or other constructs described herein or contemplated hereby may be coated with varnish, clay, or other materials, either alone or in combination. For example, at least the side of the support that will form an exterior surface of a construct
10 erected therefrom may be coated with a clay coating or other base coating. The coating may then be printed over with product advertising, images, price coding, any other information or indicia, or any combination thereof. The blank or construct then may be overcoated with a varnish to protect any information printed thereon.

15 Furthermore, the blanks or other constructs may be coated with, for example, a moisture and/or oxygen barrier layer, on either or both sides, such as those described above. Any suitable moisture and/or oxygen barrier material may be used in accordance with the present invention. Examples of materials that may be suitable include, but are not limited to, polyvinylidene chloride,
20 ethylene vinyl alcohol, DuPont DARTEK™ nylon 6,6, and others referred to above.

Alternatively or additionally, any of the blanks or other constructs of the present invention may be coated or laminated with other materials to impart other properties, such as absorbency, repellency, opacity, color, printability,
25 stiffness, or cushioning. For example, absorbent susceptors are described in U.S. Provisional Application No. 60/604,637, filed August 25, 2004, and U.S. Patent Application No. 11/211,854, to Middleton, et al., titled "Absorbent Microwave Interactive Packaging", filed August 25, 2005, both of which are incorporated herein by reference in their entirety.

It will be understood that with some combinations of elements and materials, the microwave interactive element may have a grey or silver color that is visually distinguishable from the substrate or the support. However, in some instances, it may be desirable to provide a web or construct having a uniform color and/or appearance. Such a web or construct may be more aesthetically pleasing to a consumer, particularly when the consumer is accustomed to packages or containers having certain visual attributes, for example, a solid color, a particular pattern, and so on. Thus, for example, the present invention contemplates using a silver or grey toned adhesive to join the microwave interactive elements to the substrate, using a silver or grey toned substrate to mask the presence of the silver or grey toned microwave interactive element, using a dark toned substrate, for example, a black toned substrate, to conceal the presence of the silver or grey toned microwave interactive element, overprinting the metallized side of the web with a silver or grey toned ink to obscure the color variation, printing the non-metallized side of the web with a silver or grey ink or other concealing color in a suitable pattern or as a solid color layer to mask or conceal the presence of the microwave interactive element, or any other suitable technique or combination thereof.

Returning to the figures, numerous sequences and steps may be used to form a construct **178** according to the invention. In one example, the blank **100** is folded along fold lines **110**, **112**, **114**, and **116**, and edges **150** and **160** are brought towards each other to form a sleeve **178** having ends **180** and **182** (**FIG. 1B**) and a cavity or interior space **184** therebetween (**FIGS. 1C** and **1D**).

The first major panel **104a** and the second major panel **104b** are overlapped to the extent needed to form a second main panel **104** with the gluing areas **162** and **174** at least partially concealed by the corresponding portions of major panel **104b**. Thus, except for the overlapped portion of panel **104a**, **FIG. 1A** depicts the exterior surface **186** of the construct **178** to be formed. Similarly, partial end panels **118a** and **118b** are overlapped to the

extent needed to form end panel **118**, which is substantially lentiform in shape with a somewhat semi-circular cutout **122** formed by overlapping partial cutouts **122a** and **122b**. Further, fold line segments **120a** and **120b** are overlapped as needed to form arcuate fold line **120**. In this and other aspects of the invention, it will be understood that other shapes for the end panel and cutout are contemplated hereby. For example, the end panel may be oval, rectangular, square, diamond-shaped, trapezoidal, polygonal, or may be any other regular or irregular shape. The cutout may be circular, square, or any other regular or irregular shape.

The overlapped portions may be glued or otherwise joined to form the sleeve **178** with a first removable portion **140** and a second removable portion **142**. The first minor panel **106** and second minor panel **108** form opposed side walls of the construct, which may be gusseted by folding inwardly along fold lines **132** and **134** (FIGS. **1C** and **1D**). In this example, tabs **148** and **166** are not glued or otherwise affixed to the first major panel **104a**. However, it is understood that the tabs **148** and **166** may be affixed removably to the first major panel **104a** if desired.

To use the construct, for example, a food item **F** is inserted through an end **180** or **182**, and the construct **178** with the food item **F** inside is placed into a microwave oven (not shown) to be heated. As the food item is heated, the susceptor **M** enhances browning and/or crisping of the surface of the food item. It is contemplated that in this and other aspects of the invention, any of the panels, for example, the first main panel **102**, the first major panel **104a**, or the second major panel **104b**, may include one or more fold lines, score lines, cut lines, cut crease lines, or other lines of disruption along all or a portion of the length or width thereof to accommodate the contours of the particular food item heated therein and to bring the susceptor **M** into closer proximity with the surface of the food item. Any steam generated during heating may be released

through the open ends **180** and **182** of the sleeve, or through apertures **136** and **138**.

After the item is heated sufficiently, the user may remove the food item **F** from the construct or may fold end panels **118** and **124** towards the interior **184** of the sleeve **178** to form a construct having an open end **180** and a closed end **182**, as shown in **FIG. 1D**. In this and other aspects of the invention, the end panels may be folded inwardly in any order. Thus, for example, end panel **118** may be folded inwardly before folding end panel **124** inwardly, or end panel **124** may be folded inwardly before folding end panel **118** inwardly. In either configuration, the construct **178** may be positioned in an upright position such that the food item **F** is supported by the end panels **118** and **124**, which serve as a base for the container. This provides a convenient means for comfortably handling the heated food item **F**.

As the food item **F** is consumed, the construct **178** may begin to interfere with accessing the food item **F**. If desired, the user may grasp and pull tab **148** in a direction away from the construct **178**. By doing so, the removable portion **140** will begin to separate from the remaining portions of the construct **178** along tear lines **152a**, **152b**, and **144**, as shown in **FIG. 1E**. Further pulling results in complete separation of the first removable portion **140** from the construct **178**, as shown in **FIG. 1F**.

As the food item is consumed further, the construct **178** again may begin to interfere with accessing the food item **F**. If desired, the user may grasp and pull tab **166** in a direction away from the construct **178**. By doing so, the removable portion **142** will begin to separate from the remaining portions of the construct **178** along tear lines **170a**, **170b**, and **146**, as shown in **FIG. 1F**. Further pulling results in complete separation (not shown) of the second removable portion **142** from the construct **178**, thereby providing greater access to the food item **F** therein.

Although the removable portions **140** and **142** are described herein as being removed sequentially herein, it will be understood that both panels **140** and **142** may be removed simultaneously simply by grasping both tabs **148** and **166** and tearing the panels along tear line **146**. This may be useful when, for example, the user has consumed a significant portion of the food item without having removed the first removable portion **140** and greater access is needed.

FIG. 2A depicts another exemplary blank **200** according to various aspects of the invention. In this example, the blank **200** includes a plurality of adjoined panels including a main panel **202**, a first major panel **204a**, a second major panel **204b**, a first minor panel **206**, and a second minor panel **208**. The first minor panel **206** is joined to the first major panel **204a** along a longitudinal fold line **210**. The main panel **202** is joined to the first minor panel **206** along a longitudinal fold line **212**. The second minor panel **208** is joined to the main panel **202** along a longitudinal fold line **214**. The second major panel **204b** is joined to the second minor panel **208** along a longitudinal fold line **216**. In this example, minor panels **206** and **208** are substantially equal in length, as indicated by **L2**. Additionally, fold lines **210**, **212**, **214**, and **216** are substantially parallel and substantially equal in length, **L2**. However, other lengths and configurations are contemplated hereby.

The blank **200** includes partial end panels **218a** and **218b** respectively joined to panels **204a** and **204b** along respective fold line segments **220a** and **220b**. Each of the partial end panels **218a** and **218b** respectively include a partial cutout **222a** and **222b**. The blank **200** further includes an end panel **224** joined to the main panel **202** along fold line **226**. In this example, the end panel **224** is substantially lentiform in shape. However, the end panel **224** may have any suitable shape.

The first minor panel **206** and the second minor panel **208** each include respective longitudinal fold lines **228** and **230** substantially centrally disposed and extending along the length **L2** thereof. Optionally, one or both of the first

minor panel **206** and the second minor panel **208** include respective apertures **232** and **234**. In the example shown in **FIG. 2A**, aperture **232** is substantially circular in shape and extends substantially between fold lines **210** and **212**. Likewise, aperture **234** is substantially circular in shape and extends substantially between fold lines **214** and **216**. However, as stated above, the number, shape, and positioning of such apertures may vary for a particular application.

Still viewing **FIG. 2A**, the blank **200** includes a removable portion **236** extending across and formed from least a portion of each of panels **202**, **204a**, **204b**, **206**, and **208**. The removable portion **236** is joined to the remainder of panels **202**, **204a**, and **204b** along a transverse line of disruption or tear line **238** that, in this example, is interrupted by apertures **232** and **234**. It will be understood that while the exemplary blank **200** of **FIG. 2B** includes only one removable portion **236**, any number of such panels and any configuration of such panels may be used as desired.

The removable portion **236** includes an extension or tab **240** that partially defines edge **242**. In this example, the tab **240** is somewhat arcuate in shape. However, it will be understood that the extension may have any shape as needed or desired. Tear line **244a** extends from a first end **246a** of extension **240** towards, and may abut, edge **248**. Tear line **244b** extends from a second end **246b** of tab **240** in a direction towards, and may abut, transverse tear line **238**. In this example, tear lines **244a** and **244b** are positioned relative to extension **240** such that the combination of tear line **244a**, tab **240**, and tear line **244b** is somewhat arcuate in shape. However, it will be understood that such tear lines may have any suitable shape and may or may not correspond to or extend the shape of the tab. Thus, for example, although the tab **240** is somewhat arcuate in shape, the tear line segments **244a** and **244b** may be parallel lines, zigzags, or any other configuration. Tear lines **244a** and **244b**

cooperate with tab **240** to facilitate removal of the first removable portion **236**, as will be discussed below.

The removable portion **236** also includes a cutout **248** that partially defines edge **250**. In this example, the cutout **248** also is somewhat arcuate in shape. As with the tab, the cutout may have any suitable shape as needed or desired including, but not limited to, those described above, and may or may not correspond to the shape or dimensions of the tab. The removable portion **236** also includes a gluing area **252** adjacent the cutout **248** and defined by a perimeter **254**. In the blank **200** shown in **FIG. 2A**, the gluing area **252** is shaped somewhat like an arch or bridge. However, it will be understood that the gluing area may have any suitable shape as needed or desired.

If desired, a susceptor **M** may overlies at least a portion of blank **200** (hidden from view in **FIG. 2A**, which illustrates the side of the blank that forms the exterior surface of the construct), and may form at least a portion of the interior surface of the construct **256** formed therefrom, as can be seen in **FIGS. 2B** and **2C**. However, other microwave energy interactive elements, such as those described herein, are contemplated for use with the invention.

Numerous steps and sequences thereof may be used to form a sleeve or other construct **256** according to the invention. In one example, the blank **200** is folded along fold lines **210**, **212**, **214**, and **216**, and edges **242** and **250** are brought towards each other to form a sleeve **256** with ends **258** and **260** and a cavity or interior space **262** therebetween (**FIG. 2B**).

The first and second major panels **204a** and **204b** are overlapped to the extent needed to form a second main panel **204** with gluing area **252** at least partially concealed by second major panel **204b**. Thus, except for the overlapped portion of major panel **204a**, **FIG. 2A** depicts the exterior surface **264** of the construct **256** to be formed. Similarly, partial end panels **218a** and **218b** are overlapped to the extent needed to form end panel **218**, which is substantially lentiform in shape with a somewhat semi-circular cutout **222**

formed by overlapping partial cutouts **222a** and **222b**. Further, fold line segments **220a** and **220b** are overlapped as needed to form arcuate fold line **220**. As discussed above, other shapes for the end panel and cutout are contemplated hereby.

5 The overlapped portions then may be glued or otherwise joined to form a sleeve **256** having a removable portion **236** comprising the removable portion **236** of the blank **200**. In this configuration, the first minor panel **206** and second minor panel **208** form opposed side walls for the construct **256**, which may be gusseted by folding inwardly along fold lines **228** and **230**, as shown in
10 **FIG. 2B**. In this example, extension or tab **240** is not glued or otherwise affixed to panel **204a**. However, it is understood that the tab **240** may be affixed removably to panel **204a** if desired.

To use the construct, for example, a food item **F** is inserted through an open end **258** or **260**, and the construct **256** with the food item inside is placed
15 into a microwave oven (not shown) to be heated. As the food item is heated, the susceptor **M** enhances browning and/or crisping of the surface of the food item. Any steam generated during heating may be released through the open ends **258** and **260** of the sleeve, or through apertures **232** and **234**.

After the item is heated sufficiently, the user may remove the food item
20 from the construct or may fold the end panels **218** and **224** towards the interior **262** of the sleeve **256** to form a construct or container having one open end **258** and one closed end **260** (**FIG. 2C**). By doing so, the construct **256** may be positioned such that the food item is supported by the end panels **218** and **224**, which serve as a base for the container.

25 As the food item (not shown) is consumed, the construct **256** may begin to interfere with accessing the food item. If desired, the user may grasp and pull tab or extension **240** in a direction away from the construct **256**, as shown in **FIG. 2C**. By doing so, the removable portion **236** will begin to separate from the remaining portions of the construct **256** along tear lines **244a**, **244b**,

and **238**. Further pulling results in complete separation of the removable portion **236** from the construct **256**. As a result, the food item can be accessed readily.

Another exemplary blank **300** is illustrated in **FIG. 3A**. The blank **300** includes a plurality of adjoined panels including a main panel **302**, a first major panel **304a**, a second major panel **304b**, a first minor panel **306**, and a second minor panel **308**. The first minor panel **306** is joined to first major panel **304a** along a longitudinal fold line **310**. The main panel **302** is joined to the first minor panel **306** along a longitudinal fold line **312**. The second minor panel **308** is joined to the main panel **302** along a longitudinal fold line **314**. The second major panel **304b** is joined to the second minor panel **308** along a longitudinal fold line **316**. In this example, minor panels **306** and **308** are substantially equal in length, **L3**. Additionally, fold lines **310**, **312**, **314**, and **316** are substantially parallel and substantially equal in length, **L3**. However, other lengths and configurations are contemplated hereby.

The blank **300** includes partial end panels **318a** and **318b** respectively joined to panels **304a** and **304b** along respective curved fold line segments **320a** and **320b**. Optionally, the partial end panels **318a** and **318b** each include a partial cutout **322a** and **322b**. The blank **300** includes an end panel **324** joined to the main panel **302** along a somewhat arcuate fold line **326**. In this example, the end panel **324** is substantially lentiform in shape. However, it is contemplated that the end panels may have any suitable shape.

The first minor panel **306** and the second minor panel **308** each include respective longitudinal fold lines **328** and **330** substantially centrally disposed and extending along the length **L3** thereof. Optionally, one or both of the first minor panel **306** and the second minor panel **308** include respective apertures **332** and **334**. In the example shown in **FIG. 3A**, aperture **332** is substantially circular in shape and extends between fold lines **310** and **312**. Aperture **334** is substantially circular in shape and extends between longitudinal fold lines **314**

and 316. However, as stated above, any number and configuration of apertures may be used.

Still viewing **FIG. 3A**, the blank **300** includes a removable portion **336** extending across and formed from least a portion of each of panels **302**, **304a**, **304b**, **306**, and **308**. The removable portion **336** is joined to the remainder of panels **302**, **304a**, and **304b** along a transverse tear line **338**. It will be understood that while the exemplary blank **300** of **FIG. 3A** includes only one removable portion **336**, any number of such portions or panels and any configuration of such panels may be used as desired.

The removable portion **336** includes a somewhat triangular tab **340** extending from the main panel **302**. In this example, the tab **340** comprises at least a portion of minor panel **308** and is defined by a somewhat arcuate or V-shaped cut line **344**. However, it will be understood that the location and shape of the tab **340** may vary for a particular application. Tear line **342a** extends from a first end **344a** of cut line **344** towards, and may abut, edge **346**. Tear line **342b** extends from a second end **344b** of cut line **344** in a direction towards, and may abut substantially, transverse tear line **338**. In this example, tear lines **342a** and **342b** are positioned relative to tab **340** such that the combination of tear lines **342a**, **344**, and **342b** is somewhat V-shaped. However, it will be understood that such tear lines may have any suitable shape and may or may not correspond to or extend the shape of the tab. Thus, for example, although the tab **340** is somewhat triangular, the tear line segments **342a** and **342b** may be parallel lines, zigzags, or any other configuration. Tear line segments **342a** and **342b** cooperate with tab **340** to facilitate removal of the removable portion **336**, as will be discussed below.

If desired, a susceptor **M** may overlie at least a portion of blank **300** (hidden from view in **FIG. 3A**, which illustrates the side of the blank that forms the exterior surface of the construct), and may form at least a portion of the interior surface of the construct **352** formed therefrom, as can be seen in

FIGS. 3B-3F. However, other microwave energy interactive elements, such as those described herein, are contemplated for use with the invention.

Numerous sequences of steps may be used to form a sleeve or other construct **352** according to the invention. In one example, the blank **300** is folded along longitudinal fold lines **310**, **312**, **314**, and **316**, and edges **348** and **350** are brought towards each other to form a sleeve **352** having two open ends **354** and **356** with a cavity or interior space **358** therebetween, as shown in **FIG. 3B**. The first and second major panels **304a** and **304b** are overlapped as needed to form a second main panel **304**, partial end panels **318a** and **318b** are overlapped as needed to form end panel **318**, fold line segments **320a** and **320b** are overlapped as needed to form fold line **320**, and partial cutouts **322a** and **322b** are overlapped as needed to form cutout **322**. In this example, the cutout **322** is somewhat semi-circular in shape. However, it will be understood that numerous other shapes are contemplated hereby.

The overlapped portions may be glued or otherwise joined to form a sleeve **352** including a removable portion **336** comprising the removable portion **336** of the blank **300**. The first minor panel **306** and second minor panel **308** form opposed side walls for the construct, which may be gusseted by folding inwardly along fold lines **328** and **330** (**FIG. 3D**).

To use the construct, a food item (not shown) is inserted through an open end **354** or **356**, and the construct **352** with the food item inside is placed into a microwave oven (not shown) to be heated. As the food item is heated, the susceptor **M** enhances browning and/or crisping of the surface of the food item. Any steam generated during heating may be released through open ends **354** and **356** of the sleeve or through apertures **332** and **334**.

After the item is heated sufficiently, the user may remove the food item from the construct or may fold the end panels **318** and **324** towards the interior **358** of the sleeve to form a container **352** having an open end **354** and a closed end **356**, as shown in **FIG. 3C**. The construct **352** then may be positioned in an

upright configuration with the food item supported by the inwardly folded, superposed end panels **318** and **324**, which serve as a base for the container. This provides a convenient means for gripping the food item without the discomfort of contacting the surface of the heated food item.

5 Turning to **FIGS. 3D-3F**, as the food item is consumed, the construct may begin to interfere with accessing the food item. If desired, the user may grasp and pull tab **340** in a direction away from the construct. By doing so, the removable portion **336** will begin to separate from the remaining portions of the construct along tear lines **342a**, **342b**, and **338**. Further pulling results in
10 complete separation of the removable portion **336** from the construct, thereby allowing greater access to the food item therein.

FIG. 4A illustrates yet another exemplary blank **400** according to the invention. The blank **400** includes a plurality of panels including a main panel **402**, a first major panel **404a**, a second major panel **404b**, a first minor panel
15 **406**, and a second minor panel **408** joined along various longitudinal fold lines **410**, **412**, **414**, and **416**, as shown. In this example, minor panels **406** and **408** are substantially equal in length, **L4**. Additionally, fold lines **410**, **412**, **414**, and **416** are substantially parallel and substantially equal in length, **L4**. However, other lengths and configurations are contemplated hereby.

20 The blank **400** includes partial end panels **418a** and **418b** respectively joined to panels **404a** and **404b** along respective curved fold line segments **420a** and **420b**. Optionally, partial end panel **418a** includes a locking feature **422**. The blank **400** includes an end panel **424** joined to the main panel **402** along a somewhat arcuate fold line **426**. In this example, the end panel **424** is
25 substantially lentiform in shape. However, the end panel may have any suitable shape. End panel **424** includes a somewhat T-shaped receiving slit **428** substantially centered thereon and configured to receive locking feature **422**.

The first minor panel **406** and the second minor panel **408** each include respective longitudinal fold lines **430** and **432** substantially centrally disposed

and extending along the length **L4** thereof. Optionally, one or both of the first minor panel **406** and the second minor panel **408** include respective apertures **434** and **436**. In the example shown in **FIG. 4**, aperture **434** is substantially circular in shape and extends substantially between fold lines **410** and **412**.
5 Aperture **436** is substantially circular in shape and extends substantially between longitudinal fold lines **414** and **416**. However, as stated above, any number and configuration of apertures may be used.

Still viewing **FIG. 4A**, the blank **400** includes a removable portion **438** extending across and formed from least a portion of each of panels **402**, **404a**,
10 **404b**, **406**, and **408**. The removable portion **438** is joined to the remainder of panels **402**, **404a**, and **404b** along a transverse tear line **440**. It will be understood that while the exemplary blank **400** of **FIG. 4** includes only one removable portion **438**, any number of such portions or panels and any configuration of such panels may be used as desired.

15 The removable portion **438** includes a somewhat elongate cutout **442** in the first main panel **402** and the second minor panel **408** terminating proximate to fold line **432**. The portion of cutout **442** in the first main panel **402** is somewhat semi-circular in shape with an arcuate grasping edge **444**. The portion of the cutout **442** in the second minor panel **408** is generally rectangular
20 or square in shape. Tear line **446a** extends from a first end **448a** of grasping edge **444** towards, and may abut, edge **450**. Tear line **446b** extends from a second end **448b** of grasping edge **444** in a direction towards, and may abut substantially, transverse tear line **440**. Tear lines **446a** and **446b** cooperate with grasping edge **444** to facilitate removal of the removable portion **438**
25 when the blank is formed into a sleeve or container (not shown).

If desired, a susceptor **M** may overlie at least a portion of blank **400** (hidden from view in **FIG. 4A**, which illustrates the side of the blank that forms the exterior surface of the construct), and may form at least a portion of

the interior surface of the construct **452** formed therefrom, as can be seen in **FIGS. 4B** and **4C**.

Numerous sequences of steps may be used to form a sleeve or other construct **452** according to the invention. In one example, the blank **400** is
5 folded along longitudinal fold lines **410**, **412**, **414**, and **416**, and edges **454** and **456** are brought towards each other to form a sleeve **452** having two open ends **458** and **460** and with a cavity or interior space **462** therebetween, as shown in **FIG. 4B**. The first and second major panels **404a** and **404b** are overlapped as needed to form a second main panel **404**, partial end panels **418a** and **418b** are
10 overlapped as needed to form end panel **418**, and fold line segments **420a** and **420b** are overlapped as needed to form fold line **420**. The overlapped portions may be glued or otherwise joined to form a sleeve **452** including a removable portion **438** comprising the removable portion **438** of the blank **400**. The first minor panel **406** and second minor panel **408** form opposed side walls for the
15 construct, which may be gusseted by folding inwardly along fold lines **430** and **432**.

To use the construct **452**, a food item (not shown) is inserted through an open end **458** or **460**, and the construct with the food item inside is placed into a microwave oven (not shown) to be heated. As the food item is heated, the
20 susceptor **M** enhances browning and/or crisping of the surface of the food item. Any steam generated during heating may be released through the open ends **458** and **460** of the sleeve, or through apertures **434** and **436**.

After the item is heated sufficiently, the user may remove the food item from the sleeve **452** or may fold the end panels **418** and **424** towards the
25 interior **462** of the sleeve **452** to form a construct having an open end **458** and a closed end **460**, as shown in **FIG. 4C**. If desired, locking feature **422** may be inserted into receiving slit **428** to secure the panels in the locked position (hidden from view in **FIG. 4C**). When held in an upright position, the end

panels **418** and **424** serve as a base for the container **452** to support a food item (not shown) therein.

As the food item is consumed, the construct may begin to interfere with accessing the food item. If desired, the user may insert a finger or other
5 implement into cutout **442** along grasping edge **444** and begin to separate the removable portion **438** from the remainder of the construct. By doing so, the removable portion **438** will begin to separate from the remaining portions of the construct along tear lines **446a**, **446b**, and **440**. Further pulling results in complete separation of the removable portion **438** from the construct, thereby
10 allowing greater access to the food item therein, similar to that shown in connection with **FIGS. 3D-3F**.

FIG. 5A illustrates still another exemplary blank **500** according to the invention. The blank of **FIG. 5A** is similar to the blank of **FIG. 4A**, except that cutout **542** lies within the second minor panel **508** and extends
15 substantially between fold lines **514** and **532**. The cutout **542** is somewhat square or rectangular in shape with a substantially straight grasping edge **544** substantially aligned with fold line **514**.

If desired, a susceptor **M** may overlies at least a portion of blank **500** (hidden from view in **FIG. 5A**, which illustrates the side of the blank that
20 forms the exterior surface of the construct), and may form at least a portion of the interior surface of the construct **552** formed therefrom, as can be seen in **FIG. 5B**.

The blank **500** can be formed into a sleeve (not shown) for heating, browning, and/or crisping a food item in a microwave oven. The sleeve then
25 can be transformed into a container for supporting the food item as it is consumed, as shown in **FIG. 5B**. The user may insert a finger or other implement into cutout **542** along grasping edge **544** and begin to separate the removable portion **538** from the remainder of the construct **552**. By doing so, the removable portion **538** will begin to separate from the remaining portions

of the construct along tear lines **546a**, **546b**, and **540**. Further pulling results in complete separation of the removable portion **538** from the construct, thereby allowing greater access to the food item therein, similar to that shown in connection with **FIGS. 3D-3F**.

5 **FIG. 6A** illustrates yet another exemplary blank **600** according to various aspects of the invention. The blank **600** includes a plurality of adjoined panels including a main panel **602**, a first major panel **604a**, a second major panel **604b**, a first minor panel **606**, and a second minor panel **608**. The first minor panel **606** is joined to first major panel **604a** along a longitudinal fold line **610**. The main panel **602** is joined to the first minor panel **606** along a longitudinal fold line **612**. The second minor panel **608** is joined to the main panel **602** along a longitudinal fold line **614**. The second major panel **604b** is joined to the second minor panel **608** along a longitudinal fold line **616**. Fold lines **610**, **612**, and **616** are substantially parallel and substantially equal in length, as indicated by **L5**. Fold line **614** is substantially parallel to fold lines **610**, **612**, and **616**, but is somewhat shorter in length, as indicated by **L6**.

The blank **600** includes partial end panels **618a** and **618b** respectively joined to panels **604a** and **604b** along respective curved fold line segments **620a** and **620b**. Optionally, partial end panel **618a** includes a tab or other locking feature **622**. The blank **600** also includes an end panel **624** joined to the main panel **602** along a somewhat arcuate fold line **626**. In this example, the end panel **624** is substantially lentiform in shape. However, any shape may be used. End panel **624** includes a somewhat T-shaped slit **628** substantially centered thereon and configured to receive locking feature **622**.

25 If desired, one or both of the first minor panel **606** and the second minor panel **608** may include a substantially centrally located longitudinal fold line **630** and **632**, respectively. Fold line **630** substantially bisects minor panel **606** into two similarly dimensioned segments, each having a length **L5**. Fold line **632** substantially bisects minor panel **608** into two segments of approximately

equal width, but with differing lengths, **L5** and **L6**, thereby defining a cutout **634**. The length of minor panel **606** is approximately equal to the length of the portion of minor panel **608** that lies between fold line **632** and fold line **616**. Optionally, one or both of the first minor panel **606** and the second minor panel **608** include respective apertures **636** and **638**. In the example shown in **FIG. 6A**, aperture **636** is substantially circular in shape and extends between fold lines **610** and **612**. Aperture **638** is substantially circular in shape and extends between longitudinal fold lines **614** and **616**. However, any number and configuration of apertures may be used.

10 Still viewing **FIG. 6A**, the blank **600** includes a removable portion **640** extending across and formed from least a portion of each of panels **602**, **604a**, **604b**, **606**, and **608**. The removable portion **640** is joined to the remainder of panels **602**, **604a**, and **604b** along a transverse tear line **642**. The removable portion **640** includes a somewhat rounded extension or tab **644** extending from
15 the main panel **602** adjacent to peripheral edge **646** of the blank **600**. An oblique tear line **648** extends from the tab **644** towards, and may abut, tear line **642**. It will be understood that while the exemplary blank **600** of **FIG. 6A** includes only one removable portion **640**, any number of such portions or panels and any configuration of such panels may be used as desired.

20 If desired, a susceptor **M** may overlie at least a portion of blank **600** (hidden from view in **FIG. 6A**, which illustrates the side of the blank that forms the exterior surface of the construct), and may form at least a portion of the interior surface of the construct **650** formed therefrom, as can be seen in **FIG. 6B-6D**.

25 Numerous sequences of steps may be used to form a sleeve or other construct **650** according to the invention. In one example, the blank **600** is folded along longitudinal fold lines **610**, **612**, **614**, and **616**, and edges **652** and **654** are brought towards each other to form a sleeve **650** having two open ends **656** and **658** with a cavity or interior space **660** therebetween, as shown in

FIGS. 6B and 6C. The first and second major panels **604a** and **604b** are overlapped as needed to form a second main panel **604**, partial end panels **618a** and **618b** are overlapped as needed to form end panel **618**, and tear line segments **620a** and **620b** are overlapped as needed to form tear line **620**. The overlapped portions may be glued or otherwise joined to form a sleeve **650** including a removable portion **640** comprising the removable portion **640** of the blank **600**. The first minor panel **606** and second minor panel **608** form opposed side walls for the construct, which may be gusseted by folding inwardly along fold lines **630** and **632** (**FIG. 6B**).

10 The sleeve **650** may be used in a manner described above with respect to the various other examples provided herein. After heating, end panels **618** and **624** may be folded inwardly, and tab **622** may be inserted into slit **628** to secure the panels **618** and **624** in a locked configuration. In this manner, a food item (not shown) can be supported more securely when the container **650** is positioned in an upright configuration with the food item resting on the overlapped panels **618** and **624**.

15 As shown in **FIG. 6D**, the removable portion **640** may be separated from the container **650** along tear lines **648** and **642** as needed to gain access to a food item (not shown) therein, as described above in connection with various other exemplary embodiments of the invention.

20 **FIG. 7A** illustrates still another exemplary blank **700** according to the invention. The blank of **FIG. 7A** is similar to the blank of **FIG. 6A**, except that longitudinal fold line **732** substantially bisects minor panel **708** into two similarly dimensioned segments, each having a length **L7**, such that cutout **734** extends substantially between tab **744** and fold line **716**. Thus, minor panel **708** has an overall length **L7** that is less than the length **L8** of minor panel **706**. Likewise, fold line **732** has a length **L7** that is less than the length **L8** of fold line **730**.

If desired, a susceptor **M** may overlie at least a portion of blank **700** (hidden from view in **FIG. 7A**, which illustrates the side of the blank that forms the exterior surface of the construct), and may form at least a portion of the interior surface of the construct **750** formed therefrom, as can be seen in **FIG. 7B**.

The blank **700** can be formed into a sleeve (not shown) for heating, browning, and/or crisping a food item in a microwave oven. The sleeve then can be transformed into a container for supporting the food item (not shown) as it is consumed, as shown in **FIG. 7B**. If needed, the removable portion **740** may be separated from the remainder of the container **750** along tear lines **748** and **742** as needed to gain access to the food item, as described above in connection with various other exemplary embodiments of the invention.

FIG. 8A illustrates another exemplary blank **800** according to the invention. In this example, the blank **800** includes a main panel **802**, a first major panel **804a**, a second major panel **804b**, a first minor panel **806**, and a second minor panel **808**. The first minor panel **806** is joined to first major panel **804a** along a longitudinal fold line **810**. The main panel **802** is joined to the first minor panel **806** along a longitudinal fold line **812**. The second minor panel **808** is joined to the main panel **802** along a longitudinal fold line **814**. The second major panel **804b** is joined to the second minor panel **808** along a longitudinal fold line **816**. In this example, fold lines **810**, **812**, **814**, and **816** are substantially parallel. Furthermore, fold lines **814** and **816** are substantially equal in length **L10**. However, other lengths and configurations are contemplated hereby.

The blank **800** includes a pair of partial end panels **818a** and **818b** respectively joined to panels **804a** and **804b** along respective curved fold line segments **820a** and **820b**. Partial end panels **818a** and **818b** respectively each include a partial cutout **822a** and **822b**. The blank **800** also includes an end panel **824** joined to the main panel **802** along a substantially arcuate fold line

826. In this example, the end panel **824** is substantially lentiform in shape. However, the end panel **824** may have any suitable shape.

The first minor panel **806** and the second minor panel **808** include respective fold lines **828** and **830** substantially centrally disposed and extending
5 along the respective lengths **L9** and **L10** thereof. Optionally, one or both of the first minor panel **806** and the second minor panel **808** include respective apertures **832** and **834**. In the example shown in **FIG. 8A**, aperture **832** is substantially circular in shape and extends substantially between fold lines **810** and **812**. Likewise, aperture **834** is substantially circular in shape and extends
10 substantially between fold lines **814** and **816**.

Still viewing **FIG. 8A**, panels **802**, **804a**, **804b**, **806**, and **808** collectively form a plurality of removable portion comprising tear strip sections **836a**, **836b**, **836c**, and **836d**. In this example, each section **836a**, **836b**, and **836c** initiates at panel **804a**, extends diagonally across panel **802**, and
15 terminates at panel **804b**. Section **836d** initiates at panel **804a** and terminates at main panel **802**. However, it will be understood that any number of segments may be used, and each of such segments may initiate and terminate at any panel, as needed or desired for a particular application.

Section **836a** is joined to section **836b** along an oblique tear line **838a**.
20 Section **836b** is joined to section **836c** along an oblique tear line **838b**. Section **836c** is joined to section **836d** along an oblique tear line **838c**. In this example, tear lines **838a**, **838b**, and **838c** are substantially parallel. However, other configurations may be used with the invention. The various tear strip sections **836a**, **836b**, **836c**, and **836d** and tear line segments **838a**, **838b**, and **838c** are
25 positioned so that when the blank is formed into a sleeve or other construct, the terminus of one panel and corresponding tear line is the origin of the next. In this manner, a single, continuous tear strip **836** is formed along a substantially continuous oblique tear line **838**, as will be discussed in connection with **FIGS. 8B-8F**. The blank **800** includes a tab **840** or other grasping feature that

facilitates tearing of the tear strip **836** along tear line **838**. The tab **840** may have any suitable shape as desired. In this example, the tab **840** is shown as being a portion of the first major panel **804a**. However, the tab **840** may be a portion of any of the various other panels, for example, panels **802**, **806**, **808**,
5 or **804b**.

If desired, a susceptor **M** may overlies at least a portion of blank **800** (hidden from view in **FIG. 8A**, which illustrates the side of the blank that forms the exterior surface of the construct), and forms at least a portion of the interior surface of the construct **842** formed therefrom, as can be seen in **FIGS.**
10 **8B-8G**. However, other microwave energy interactive elements, such as those described herein, are contemplated for use with the invention.

Turning to **FIGS. 8B-8C**, numerous processes may be used to form a sleeve or other construct **842** according to the invention. In one example, the blank **800** is folded along fold lines **810**, **812**, **814**, and **816**, and edges **844** and
15 **846** are brought towards each other to form a sleeve **842** with two ends **848** and **850** and cavity or interior space **852** therebetween.

The first and second major panels **804a** and **804b** are overlapped to the extent needed to form a second main panel **804**. Partial end panels **818a** and **818b** are overlapped to the extent needed to form end panel **818**. Fold line segments **820a** and **820b** are overlapped as needed to form arcuate fold line
20 **820**. Partial cutouts **822a** and **822b** are overlapped as needed to form cutout **822**. In this example, the end panel **818** is substantially lentiform in shape and the cutout is somewhat semi-circular in shape. However, other shapes are contemplated hereby, such as those described above in relation to end panel
25 **824**. The overlapped portions may be glued or otherwise joined to form a sleeve **842** having a removable portion **836**. The first minor panel **806** and second minor panel **808** form opposed side walls for the construct **842**, which may be gusseted (not shown) by folding inwardly along fold lines **828** and **830**.

To use the construct, a food item (not shown) is inserted through an end 848 or 850, and the sleeve 842 with the food item inside is placed into a microwave oven (not shown) to be heated. As the food item is heated, the susceptor M enhances browning and/or crisping of the surface of the food item.

5 Any steam generated during heating may be released through the open ends 848 and 850 of the sleeve, or through apertures 832 and 834.

After the item is heated sufficiently, the user may remove the food item from the construct or may fold the end panels 818 and 824 toward the interior 852 of the sleeve 842 to form a container 842 having one open end 848 and one

10 closed end 850, as shown in FIG. 8D. The construct 842 then may be positioned in an upright configuration such that end panels 818 and 824 serve as a base to support the food item. This provides a convenient means for handling and transporting the heated food item without having to contact the surface of the food item.

15 Turning to FIGS. 8E-8G, as the food item (not shown) is consumed, the user may grasp tab 840 and initiate separation of the tear strip 836 from the remainder of the construct 842. Further pulling results in continuous separation of the tear strip 836 from the construct 842 until the tear strip 836 reaches its terminus, thereby permitting the user to attain access to the food item as needed

20 or desired.

FIG. 9A depicts yet another exemplary blank 900 according to various aspects of the present invention. The blank 900 generally includes a main panel 902, a first major panel 904a, a second major panel 904b, a first minor panel 906, and a second minor panel 908. The first minor panel 906 is joined

25 to first major panel 904a along a longitudinal tear line 910. The main panel 902 is joined to the first minor panel 906 along a longitudinal tear line 912. The second minor panel 908 is joined to the main panel 902 along a longitudinal tear line 914. The second major panel 904b is joined to the second minor panel 908 along a longitudinal tear line 916. In this example, tear lines

910, 912, 914, and 916 are substantially parallel and substantially equal in length, **L11**. However, other configurations are contemplated.

According to various aspects of the invention, one or more of panels **902, 904a, 904b, 906, and 908** may serve as a removable portion of the blank **900**. Any of such panels may be separated at least partially from an adjacent panel by tearing along at least one of tear lines **910, 912, 914, and 916**. For example, first major panel **904a** may be separated at least partially from the remainder of the blank **900** by tearing along tear line **910**. First minor panel **906** may be separated at least partially from the remainder of the blank **900** by tearing along tear line **910** and/or tear line **912**. Main panel **902** may be separated at least partially from the remainder of the blank **900** by tearing along tear line **912** and/or tear line **914**. Second minor panel **908** may be separated at least partially from the remainder of the blank **900** by tearing along tear line **914** and/or tear line **916**. Second major panel **904b** may be separated at least partially from the remainder of the blank **900** by tearing along tear line **916**. As will be shown below, tear lines **910, 912, 914, and 916** also serve as fold lines in forming a construct. However, it is contemplated that the removable portion of the blank may be formed or defined by one or more lines of disruption that do not also serve as fold lines.

Still viewing **FIG. 9A**, partial end panels **918a** and **918b** respectively are joined to major panels **904a** and **904b** along respective curved fold line segments **920a** and **920b**. Partial end panels **918a** and **918b** respectively include a partial cutout **922a** and **922b**. The blank **900** also includes an end panel **924** joined to the main panel **902** along fold line **926**. In this example, the end panel **924** is substantially lentiform in shape. Other shapes are contemplated hereby.

The first and second major panels **904a** and **904b** include respectively aligned transverse fold line segments **928a** and **928b**. Fold line **928a** extends between and is substantially perpendicular to edge **930** and tear line **910**. Fold

line **928b** extends between and is substantially perpendicular to edge **932** and tear line **916**. Likewise, the first major panel includes a transverse fold line **934** extending between and substantially perpendicular to tear line **912** and tear line **914**. In the example shown in **FIG. 9A**, fold lines **928a**, **934**, and **928b** are in
5 substantial alignment. However, it will be understood that fold line **934** may not be aligned with segments **928a** and **928b** if needed or desired. Additionally, any of fold lines **928a**, **928b**, and **934** may be tear lines or other lines of disruption if needed or desired.

The first minor panel **906** and the second minor panel **908** include
10 respective fold lines **936** and **938** substantially centrally disposed and extending along the length **L12** thereof. The first minor panel **906** and the second minor panel **908** also include respective extensions or tabs **940** and **942** that extend beyond panels **902**, **904a**, and **904b**, such that the overall length **L12** of each of minor panels **906** and **908** including respective extensions **940** and **942** is
15 greater than the length **L11** of panels **902**, **904a**, and **904b** (measured at the longest point). In this example, the tabs **940** and **942** are somewhat semi-circular or obround in shape. However, numerous other shapes are contemplated hereby. For example, each tab or extension independently may be triangular, square, rectangular, or any other regular or irregular shape as
20 desired.

Optionally, one or both of the first minor panel **906** and the second minor panel **908** include respective apertures **944** and **946**. In the example shown in **FIG. 9A**, aperture **944** is substantially circular in shape and extends substantially between tear lines **910** and **912**. Likewise, aperture **946** is
25 substantially circular in shape and extends substantially between tear lines **914** and **916**.

If desired, a susceptor **M** or other microwave energy interactive element may overlie at least a portion of blank **900**, and may form at least a portion of

the interior surface of the construct **948** formed therefrom, as can be seen in **FIGS. 9D** and **9E**.

Turning to **FIGS. 9B-9E**, numerous sequences of steps may be used to form a sleeve or other construct **948** according to the invention. In one example, the blank **900** is folded along fold lines **910**, **912**, **914**, and **916**, and edges **930** and **932** are brought towards each other to form a sleeve **948** with two ends **950** and **952** and cavity or interior space **954** therebetween. The first and second major panels **904a** and **904b** are overlapped to the extent needed to form a second main panel **904**. Fold line segments **928a** and **928b** are overlapped as needed to form fold line **928**. Partial end panels **918a** and **918b** are overlapped to the extent needed to form end panel **918**. Fold line segments **920a** and **920b** are overlapped as needed to form an arcuate fold line (not shown). Partial cutouts **922a** and **922b** are overlapped as needed to form a cutout (not shown).

The overlapped portions may be glued or otherwise joined. The first minor panel **906** and second minor panel **908** form opposed side walls for the construct **948**, which may be gusseted by folding inwardly along respective fold lines **936** and **938**.

To use the construct, for example, a food item **F** is inserted through an end **950** or **952**, and the construct **948** with the food item inside is placed into a microwave oven (not shown) to be heated. As the food item is heated, the susceptor **M** enhances browning and/or crisping of the surface of the food item. Any steam generated during heating may be released through the open ends **950** and **952** of the sleeve, or through apertures **944** and **946**.

After the item is heated sufficiently, the user may remove the food item from the construct or may, as described above, fold the end panels **918** and **924** toward the interior **954** of the construct **948** to form a construct having one open end **950** and one closed end **952**, as shown in **FIG. 9C**. The construct

948 then may be positioned such that the inwardly folded end panels 918 and 924 serve as a base to support the food item.

Turning to FIGS. 9D and 9E, as the food item F is consumed, the user may grasp one or both of tabs 940 and 942 and initiate separation of the corresponding minor panels 906 and 908 along the respective tear lines 910 and 912 and/or 914 and 916 from the remainder of the construct 948. In this example, separation of the minor panels 906 and 908 from the construct will cease upon reaching apertures 944 and 946. If additional separation is desired, tearing can be initiated again. As shown in FIG. 9E, one or both of the major panels 902 and 904 may be folded along respective fold lines 928 and/or 934 to improve access to the food product contained within the construct 948. Where one or both of fold lines 928 and 934 are tear lines, such folded portions may be removed if desired. As is apparent from FIG. 9E, the construct facilitates ready access to the food product being consumed.

In this example, one or both of the first minor panel 906 and the second minor panel and 906 may be said to comprise removable portions of the construct. However, it will be understood that one or both of the first main panel 902 and second main panel 904 also may be considered to be the removable portion of the construct, since the various panels are separated along the tear lines adjacent to such panels. Thus, for a given embodiment of the invention, the removable portion may be characterized in numerous different ways, without limitation.

FIG. 10A depicts another exemplary blank 1000 according to the invention. In this example, the blank 1000 generally includes a main panel 1002, a first major panel 1004a, a second major panel 1004b, a first minor panel 1006, and a second minor panel 1008. The first minor panel 1006 is joined to first major panel 1004a along a longitudinal fold line 1010. The main panel 1002 is joined to the first minor panel 1006 along a longitudinal fold line 1012. The second minor panel 1008 is joined to the main panel 1002 along a

longitudinal fold line **1014**. The second major panel **1004b** is joined to the second minor panel **1008** along a longitudinal fold line **1016**. In this example, fold lines **1010**, **1012**, **1014**, and **1016** are shown as being substantially parallel and substantially equal in length, **L13**. However, other configurations of fold lines are contemplated hereby.

Still viewing **FIG. 10A**, partial end panels **1018a** and **1018b** are joined respectively to panels **1004a** and **1004b** along respective curved fold line segments **1020a** and **1020b**. Partial end panels **1018a** and **1018b** respectively optionally include partial cutouts **1022a** and **1022b**. End panel **1024** is joined to the main panel **1002** along a pair of somewhat arcuate or curved fold lines **1026**. In this example, end panel **1024** is substantially lentiform in shape, but other shapes are contemplated hereby.

The main panel **1002** includes a removable portion **1028** defined by a line of disruption **1030**, for example, a tear line in the form of an offset kiss cut line, that initiates and terminates along the peripheral edge **1032** of the blank **1000** adjacent to the main panel **1002**. In the example illustrated in **FIG. 10A**, the removable portion **1028** generally resembles an arrow with an arcuate tab or extension **1034** defined at least partially by a cut line or slit **1036** adjacent to end panel **1024**. The tab **1034** generally may be shaped to facilitate separation of the removable portion **1028** from the main panel **1002**.

The first minor panel **1006** and the second minor panel **1008** each include respective longitudinal fold lines **1038** and **1040** substantially centrally disposed and extending along the length **L13** thereof. Optionally, one or both of the first minor panel **1006** and the second minor panel **1008** include respective apertures **1042** and **1044**. In the example shown in **FIG. 10A**, aperture **1042** is substantially circular in shape and extends substantially between fold lines **1010** and **1012**. Likewise, aperture **1044** is substantially circular in shape and extends substantially between fold lines **1014** and **1016**.

If desired, a susceptor **M** or other microwave energy interactive element may overlie at least a portion of blank **1000** and may form at least a portion of the interior surface of the construct **1046** formed therefrom, as shown in **FIGS. 10B-10E**. To form a sleeve or other construct **1046** from the blank **1000**, the blank **100** may be folded along fold lines **1010**, **1012**, **1014**, and **1016**, and edges **1048** and **1050** brought towards each other to form a sleeve **1046** having opposed ends **1052** and **1054** and cavity or interior space **1056** therebetween. The first and second major panels **1004a** and **1004b** are overlapped as needed to form a second main panel **1004**. Partial end panels **1018a** and **1018b** are overlapped to the extent needed to form end panel **1018**. Fold line segments **1020a** and **1020b** are overlapped to form a substantially arcuate fold line **1020**. Partial cutouts **1022a** and **1022b** are overlapped as needed to form cutout **1022**. The overlapped portions may be glued or otherwise joined, as shown in **FIG. 10B**. In this configuration, the first minor panel **1006** and second minor panel **1008** form opposed side walls for the construct **1046**, which may be gusseted by folding inwardly along fold lines **1038** and **1040**, as shown in **FIGS. 10B and 10C**.

To use the construct, for example, a food item **F** (shown in **FIG. 10D**) is inserted through an end **1052** or **1054**, and the construct **1046** with the food item inside is placed into a microwave oven (not shown) to be heated. As the food item is heated, the susceptor **M** enhances browning and/or crisping of the surface of the food item. Any steam generated during heating may be released through the open ends **1052** and **1054** of the sleeve, or through apertures **1042** and **1044**.

After the item is heated sufficiently, the user may remove the food item from the construct or may fold the panels **1018** and **1024** toward the interior **1056** of the construct **1046** to form a container having one closed end **1052** and one open end **1054**, as shown in **FIG. 10C**. The construct **1046** then may be positioned in an upright configuration such that the food item **F** is supported by

the end panels **1018** and **1024**, with end panels **1018** and **1024** serving as a container base.

Turning to **FIG. 10D**, as the food item **F** is consumed, the user may grasp tab **1034** and initiate separation of the removable portion **1028** from the remainder of the construct **1046** along score line **1030**, thereby improving
5 access to the food product contained therein. If desired, the removable portion **1028** may be removed completely, as shown in **FIG. 10E** (without the food item).

FIG. 11A illustrates yet another exemplary blank **1100** according to various aspects of the present invention. In this example, blank **1100** includes
10 a plurality of adjoined panels including a main panel **1102**, a first major panel **1104a**, a second major panel **1104b**, a first minor panel **1106**, and a second minor panel **1108**. The first minor panel **1106** is joined to first major panel **1104a** along a longitudinal fold line **1110**. The main panel **1102** is joined to
15 the first minor panel **1106** along a fold line longitudinal **1112**. The second minor panel **1108** is joined to the main panel **1102** along a longitudinal fold line **1114**. The second major panel **1104b** is joined to the second minor panel **1108** along a longitudinal fold line **1116**.

Partial end panels **1118a** and **1118b** respectively are joined to first major
20 panel sections **1104a** and **1104b** along respective curved fold line segments **1120a** and **1120b**. End panel **1122** is joined to the main panel **1102** along a somewhat arcuate fold line **1124**.

The main panel **1102** includes a removable portion **1126** defined by a tear line **1128**. In this example, tear line **1128** is a zipper cut line, i.e., a tear
25 line defined by a plurality of spaced apart slits, each having a smaller slit extending obliquely therefrom. However, other types of lines of disruption may be used. The removable portion **1126** extends substantially from edge **1130** and includes an extension or tab **1132** comprising at least a portion of end panel **1122**. In the example illustrated in **FIG. 11A**, the removable portion

1126 is shown as being somewhat elongate in shape with an arcuate tab **1132**. However, other shapes and dimensions for the removable portion and optional tab are contemplated hereby. If desired, the tab **1132** may be defined further by a cut line or slit **1134** or nick (not shown) along the arcuate portion of tear line **1128** to facilitate grasping thereof.

The first minor panel **1106** and the second minor panel **1108** each include respective longitudinal fold lines **1136** and **1138** substantially centrally disposed and extending along the length **L14** thereof. Optionally, one or both of the first minor panel **1106** and the second minor panel **1108** include respective apertures **1140** and **1142**. In the example shown in **FIG. 11A**, aperture **1140** is substantially circular in shape and extends between fold lines **1110** and **1112**. Likewise, aperture **1142** is substantially circular in shape and extends between fold lines **1114** and **1116**. However, the number, shape, and positioning of such apertures may vary for a particular application.

If desired, a microwave energy interactive element **M** may overlie at least a portion of at least one side of the blank **1100**, and may form at least a portion of the interior surface of a construct **1144** formed therefrom, as shown in **FIG. 11B**.

To form a sleeve or other construct **1144**, the blank **1100** may be folded along fold lines **1110**, **1112**, **1114**, and **1116**, and edges **1146** and **1148** brought towards each other to form a sleeve **1144** with two open ends **1150** and **1152** and a cavity or interior space **1154** therebetween. The first and second major panels section **1104a** and **1104b** are overlapped to the extent needed to form a second main panel **1104**. Partial end panels **1118a** and **1118b** are overlapped to the extent needed to form end panel **1118**. Fold line segments **1120a** and **1120b** are overlapped as needed to form substantially arcuate fold line **1120**. The overlapped portions may be glued or otherwise joined. In this configuration, the first minor panel **1106** and second minor panel **1108** form

opposed side walls for the construct, which may be gusseted by folding inwardly along fold lines **1136** and **1138**.

To use the construct **1144**, a food item (not shown) is inserted through an open end, and the construct with the food item inside is placed into a microwave oven (not shown) to be heated. After the item is heated sufficiently, the user may remove the food item from the construct or may fold the end panels **1118** and **1122** inwardly to form a construct having one closed end and one open end (not shown). By doing so, the construct may be positioned such that the food item is supported by the inwardly folded end panels **1118** and **1122**, thereby providing a convenient means for handling and transporting the heated food item without having to contact the surface of the food item. As the food item is consumed, the user may grasp tab **1132** and initiate separation of the removable portion **1126** from the remainder of the construct along zipper cut line **1128**, thereby improving access to the food product contained therein.

In the examples shown herein, the construct is somewhat rectangular in shape, suitable, for example, for heating a sandwich or breakfast pastry therein. However, it will be understood that in this and other aspects of the invention described herein or contemplated hereby, numerous suitable shapes and configurations may be used to form the various panels and, therefore, constructs. Examples of other shapes encompassed hereby include, but are not limited to, polygons, circles, ovals, cylinders, prisms, spheres, polyhedrons, and ellipsoids. The shape of each panel may be determined largely by the shape of the food item, and it should be understood that different packages are contemplated for different food items, for example, sandwiches, pizzas, French fries, soft pretzels, pizza bites, cheese sticks, pastries, doughs, and so forth. The construct may be flexible, semi-rigid, rigid, or may include a variety of components having different degrees of flexibility. Likewise, the construct may include gussets, pleats, or any other feature needed or desired to

accommodate a particular food item and/or portion size. Additionally, it will be understood that the present invention contemplates blanks and constructs for single-serving portions and for multiple-serving portions.

Although certain embodiments of this invention have been described
5 with a certain degree of particularity, those skilled in the art could make numerous alterations to the disclosed embodiments without departing from the spirit or scope of this invention. All directional references (e.g., upper, lower, upward, downward, left, right, leftward, rightward, top, bottom, above, below, vertical, horizontal, clockwise, and counterclockwise) are used only for
10 identification purposes to aid the reader's understanding of the various embodiments of the present invention, and do not create limitations, particularly as to the position, orientation, or use of the invention unless specifically set forth in the claims. Joinder references (e.g., joined, attached, coupled, connected, and the like) are to be construed broadly and may include
15 intermediate members between a connection of elements and relative movement between elements. As such, joinder references do not necessarily imply that two elements are connected directly and in fixed relation to each other.

It will be understood that in each of the various blanks and trays
20 described herein and contemplated hereby, a "fold line" can be any substantially linear, although not necessarily straight, form of weakening that facilitates folding therealong. More specifically, but not for the purpose of narrowing the scope of the present invention, a fold line may be a score line, such as lines formed with a blunt scoring knife, or the like, which creates a
25 crushed portion in the material along the desired line of weakness, a cut that extends partially into a material along the desired line of weakness, and/or a series of cuts that extend partially into and/or completely through the material along the desired line of weakness; or any combination of these features.

For example, one type of conventional tear line is in the form of a series of cuts that extend completely through the material, with adjacent cuts being spaced apart slightly so that a nick (e.g., a small somewhat bridging-like piece of the material) is defined between the adjacent cuts for typically temporarily
5 connecting the material across the tear line. The nicks are broken during tearing along the tear line. Such a tear line that includes nicks can also be referred to as a cut line, since the nicks typically are a relatively small percentage of the subject line, and alternatively the nicks can be omitted from such a cut line.

10 Furthermore, various exemplary blanks and constructs are shown and described herein as having fold lines, tear lines, score lines, cut lines, kiss cut lines, and other lines as extending from a particular feature to another particular feature, for example from one particular panel to another, from one particular edge to another, or any combination thereof. However, it will be understood
15 that such lines need not necessarily extend between such features in a precise manner. Instead, such lines may generally extend between the various features as needed to achieve the objective of such line. For instance, where a particular tear line is shown as extending from a first edge of a blank to another edge of the blank, the tear line need not extend completely to one or both of such
20 edges. Rather, the tear line need only extend to a location sufficiently proximate to the edge so that the removable strip, panel, or portion can be manually separated from the blank or construct without causing undesirable damage thereto.

Accordingly, it will be readily understood by those persons skilled in the
25 art that, in view of the above detailed description of the invention, the present invention is susceptible of broad utility and application. Many adaptations of the present invention other than those herein described, as well as many variations, modifications, and equivalent arrangements will be apparent from or reasonably suggested by the present invention and the above detailed

description thereof, without departing from the substance or scope of the invention as set forth in the following claims.

While the present invention is described herein in detail in relation to specific aspects, it is to be understood that this detailed description is only
5 illustrative and exemplary of the present invention and is made merely for purposes of providing a full and enabling disclosure of the present invention and to provide the best mode contemplated by the inventor or inventors of carrying out the invention. The detailed description set forth herein is not
10 intended nor is to be construed to limit the present invention or otherwise to exclude any such other embodiments, adaptations, variations, modifications, and equivalent arrangements of the present invention.

What is claimed is:

1. A blank for forming a construct, comprising:
 - a plurality of adjoined panels, each panel having a first dimension extending in a first direction and a second dimension extending in a second direction, the first direction being substantially perpendicular to the second direction;
 - a microwave energy interactive element overlying at least a portion of at least one of the adjoined panels; and
 - a removable portion defined at least partially by a tear line extending in the second direction at least partially across at least one of the adjoined panels.
2. The blank of claim 1, wherein the tear line extends in the second direction substantially across each of the adjoined panels.
3. The blank of claim 1, wherein
 - the removable portion is a first removable portion,
 - the tear line is a first tear line,
 - the blank further comprises a second removable portion defined at least partially by a second tear line extending in the second direction at least partially across the blank, and
 - the first tear line is substantially parallel to the second tear line.
4. The blank of claim 3, wherein at least one of the first tear line and the second tear line is interrupted by an aperture.
5. The blank of claim 1, wherein the plurality of panels includes
 - a main panel,
 - a first minor panel joined to the main panel,

a second minor panel joined to the main panel,
a first major panel joined to the first minor panel, and
a second major panel joined to the second minor panel, and
wherein the main panel, the first minor panel, the second minor panel,
the first major panel, and the second major panel are joined respectively to one
another along a plurality of respective substantially parallel fold lines extending
in the first direction.

6. The blank of claim 5, wherein
the removable portion comprises a cutout along a peripheral edge of the
first major panel, and
the peripheral edge extends in the first direction.
7. The blank of claim 5, wherein
the removable portion comprises a tab extending from a peripheral edge
of the second major panel, and
the peripheral edge extends in the first direction.
8. The blank of claim 5, wherein the removable portion comprises a tab at
least partially defined by a line of disruption in the main panel.
9. The blank of claim 5, wherein the removable portion comprises a tab
formed from at least a portion of the main panel and at least a portion of the
second minor panel.
10. The blank of claim 5, formed into a sleeve for heating, browning, and/or
crisping a food item in a microwave oven, wherein
the main panel is a first main panel,

the first major panel and the second major panel collectively form a second main panel having a dimension in the second direction that is approximately equal to that of the first main panel,

the first main panel and the second main panel have an opposed relation,

the first minor panel and the second minor panel have an opposed relation,

the first main panel, the second main panel, the first minor panel, and the second minor panel collectively define a cavity having an interior surface, and

the microwave energy interactive element overlies at least a portion of the interior surface.

11. The blank of claim 5, further comprising a substantially lentiform end panel joined to the main panel along a substantially arcuate fold line.

12. The blank of claim 11, further comprising:

a first partial end panel joined to the first major panel along a first curved fold line; and

a second partial end panel joined to the second major panel along a second curved fold line.

13. The blank of claim 12, formed into a container for heating, browning, and/or crisping a food item in a microwave oven, wherein

the main panel is a first main panel,

the end panel is a first end panel,

the first major panel and the second major panel overlap to form a second main panel opposed to the first main panel,

the first partial end panel and the second partial panel overlap to form a second end panel,

the first main panel, the second main panel, the first minor panel, and the second minor panel collectively define a cavity, and

the first end panel and the second end panel are folded inwardly towards the cavity.

14. The blank of claim 1, wherein the microwave energy interactive element comprises a susceptor, a foil, a segmented foil, or any combination thereof.

15. A blank for forming a construct, comprising:

a plurality of adjoined panels, each panel having a first dimension extending in a first direction and a second dimension extending in a second direction, the first direction being substantially perpendicular to the second direction;

a microwave energy interactive element overlying at least a portion of at least one of the adjoined panels; and

a removable portion defined at least partially by

an oblique tear line, and

a transverse tear line extending in the second direction at least partially across at least one of the adjoined panels.

16. The blank of claim 15, wherein the transverse tear line extends in the second direction substantially across each of the adjoined panels.

17. The blank of claim 15, wherein

the removable portion includes a tab, and

the oblique tear line extends substantially between the tab and the transverse tear line.

18. The blank of claim 15, wherein the removable portion is defined further by an aperture.
19. The blank of claim 15, wherein the plurality of panels includes
a main panel,
a first minor panel joined to the main panel,
a second minor panel joined to the main panel,
a first major panel joined to the first minor panel, and
a second major panel joined to the second minor panel, and
wherein the main panel, the first minor panel, the second minor panel,
the first major panel, and the second major panel are joined respectively to one
another along a plurality of respective substantially parallel fold lines extending
in the first direction.
20. The blank of claim 19, wherein
the second minor panel includes a cutout extending inwardly from a
peripheral edge of the blank, and
the peripheral edge extends in the second direction.
21. The blank of claim 20, wherein the removable portion includes a tab
extending from the main panel into the cutout.
22. The blank of claim 19, formed into a sleeve for heating, browning,
and/or crisping a food item in a microwave oven, wherein
the main panel is a first main panel,
the first major panel and the second major panel collectively form a
second main panel having a dimension in the second direction that is
approximately equal to that of the first main panel,
the first main panel and the second main panel have an opposed relation,

the first minor panel and the second minor panel have an opposed relation,

the first main panel, the second main panel, the first minor panel, and the second minor panel collectively define a cavity having an interior surface, and

the microwave energy interactive element overlies at least a portion of the interior surface.

23. The blank of claim 19, further comprising a substantially lentiform end panel joined to the main panel along a substantially arcuate fold line.

24. The blank of claim 19, further comprising:

a first partial end panel joined to the first major panel along a first curved fold line; and

a second partial end panel joined to the second major panel along a second curved fold line.

25. The blank of claim 24, formed into a container for heating, browning, and/or crisping a food item in a microwave oven, wherein

the main panel is a first main panel,

the end panel is a first end panel,

the first major panel and the second major panel overlap to form a second main panel opposed to the first main panel,

the first partial end panel and the second partial panel overlap to form a second end panel,

the first main panel, the second main panel, the first minor panel, and the second minor panel collectively define a cavity, and

the first end panel and the second end panel are folded inwardly towards the cavity.

26. The blank of claim 15, formed into a container having an interior space, the container comprising:

a pair of opposed main panels;

a pair of opposed minor panels joined to the main panels along respective fold lines;

a pair of end panels folded along respective substantially arcuate fold lines toward the interior space in a superposed configuration; and

a removable portion comprising the removable portion of the blank.

27. The blank of claim 15, wherein the microwave energy interactive element comprises a susceptor, a foil, a segmented foil, or any combination thereof.

28. A blank for forming a construct, comprising:

a plurality of adjoined panels including

a main panel,

a first minor panel joined to the main panel,

a second minor panel joined to the main panel,

a first major panel joined to the first minor panel, and

a second major panel joined to the second minor panel,

the main panel, the first minor panel, the second minor panel, the first major panel, and the second major panel being joined respectively to one another along a plurality of respective substantially parallel fold lines extending in a first direction; and

a removable portion defined at least partially by

an oblique tear line in the main panel, the oblique tear line extending from a tab proximate a peripheral edge extending in a second direction substantially perpendicular to the first direction, and

a transverse tear line extending in the second direction substantially across the main panel.

29. The blank of claim 28, wherein the oblique tear line extends substantially between the tab and the transverse tear line.

30. The blank of claim 28, wherein the tab is positioned adjacent to a cutout in the blank.

31. The blank of claim 28, wherein the first minor panel and the second minor panel each have a length, and the length of the second minor panel is less than the length of the first minor panel.

32. The blank of claim 28, wherein the second minor panel includes at least a portion of the cutout.

33. A blank for forming a construct, comprising:

a plurality of adjoined panels, each having a first dimension extending in a first direction and a second dimension extending in a second direction, the first direction being substantially perpendicular to the second direction;

a microwave energy interactive element overlying at least a portion of at least one of the adjoined panels; and

a removable portion defined by a tear line extending obliquely across at least a portion of at least one of the plurality of panels.

34. The blank of claim 33, wherein

the removable portion is a first removable portion of a plurality of removable portions,

the tear line is a first tear line of a plurality of a tear lines that define the plurality of removable portions, and

each of the plurality of tear lines extend obliquely across at least a portion of at least one of the plurality of panels.

35. The blank of claim 34, wherein the plurality of tear lines are substantially parallel.

36. The blank of claim 34, formed into a construct for heating, browning, and/or crisping a food item in a microwave oven, wherein

the construct includes a removable portion comprising at least one of the plurality of removable portions of the blank; and

the microwave energy interactive element comprises a susceptor.

37. The blank of claim 34, formed into a construct for heating, browning, and/or crisping a food item in a microwave oven, wherein the plurality of removable portions of the blank are adjoined to form a substantially continuous removable portion.

38. The blank of claim 33, wherein the microwave energy interactive element comprises a susceptor, a foil, a segmented foil, or any combination thereof.

39. The blank of claim 33, wherein the plurality of panels includes

a main panel,

a first minor panel joined to the main panel,

a second minor panel joined to the main panel,

a first major panel joined to the first minor panel, and

a second major panel joined to the second minor panel, and

wherein the main panel, the first minor panel, the second minor panel, the first major panel, and the second major panel are joined respectively to one another along a plurality of respective substantially parallel fold lines extending in the first direction.

40. The blank of claim 39, wherein
the removable portion comprises a tab extending from a peripheral edge of the second major panel, and

the peripheral edge extends in the second direction.

41. The blank of claim 39, wherein a portion of the first major panel has a first dimension that is approximately equal to the first dimension of the second major panel.

42. The blank of claim 39, wherein a portion of the first major panel has a first dimension that is greater than the first dimension of the second major panel.

43. The blank of claim 39, further comprising a substantially lentiform end panel joined to the main panel along a substantially arcuate fold line.

44. The blank of claim 43, further comprising:

a first partial end panel joined to the first major panel along a first curved fold line; and

a second partial end panel joined to the second major panel along a second curved fold line.

45. The blank of claim 44, formed into a sleeve for heating, browning, and/or crisping a food item in a microwave oven, wherein

the main panel is a first main panel,

the end panel is a first end panel,
the first major panel and the second major panel overlap to form a second main panel,
the first partial end panel and the second partial panel overlap to form a second end panel having a dimension in the second direction that is approximately equal to that of the first end panel,
the first main panel and the second main panel have an opposed relation,
the first minor panel and the second minor panel have an opposed relation,
the first main panel, the second main panel, the first minor panel, and the second minor panel collectively define a cavity and an interior surface, and
the microwave energy interactive element overlies at least a portion of the interior surface.

46. The blank of claim 45, wherein the microwave energy interactive element comprises a metallized film.

47. The blank of claim 44, formed into a container for a food item in a microwave oven, wherein

the main panel is a first main panel,
the end panel is a first end panel,
the first major panel and the second major panel overlap to form a second main panel opposed to the first main panel,
the first partial end panel and the second partial panel overlap to form a second end panel,
the first main panel, the second main panel, the first minor panel, and the second minor panel collectively define a cavity,
the first end panel and the second end panel are folded inwardly toward the cavity, and

the container includes a removable portion comprising the removable portion of the blank.

48. A blank for forming a construct, comprising:

a plurality of adjoined panels, each having a first dimension extending in a first direction and a second dimension extending in a second direction, the first direction being substantially perpendicular to the second direction;

a microwave energy interactive element overlying at least a portion of at least one of the plurality adjoined panels; and

a removable portion defined by a tear line that extends in the first direction and adjoins a first pair of adjacent panels of the plurality of adjoined panels.

49. The blank of claim 48, wherein

the tear line is a first tear line, and

the removable portion is defined further by a second tear line that extends in the first direction and adjoins a second pair of adjacent panels.

50. The blank of claim 49, wherein one panel of the first pair of panels is one panel of the second pair of panels.

51. The blank of claim 48, further comprising a foldable portion defined at least partially by a fold line extending in the second direction across at least one of the plurality of adjoined panels.

52. The blank of claim 48, wherein the microwave energy interactive element comprises a susceptor, a foil, a segmented foil, or any combination thereof.

53. The blank of claim 48, wherein the plurality of adjoined panels includes a main panel,
a first minor panel joined to the main panel,
a second minor panel joined to the main panel,
a first major panel joined to the first minor panel, and
a second major panel joined to the second minor panel,
wherein the main panel, the first minor panel, the second minor panel, the first major panel, and the second major panel are joined respectively to one another along a plurality of respective substantially parallel fold lines, tear lines, or any combination thereof extending in the first direction.
54. The blank of claim 53, wherein the removable portion comprises at least one of the first minor panel and the second minor panel.
55. The blank of claim 53, wherein the removable portion comprises at least one of the first major panel and the second major panel.
56. The blank of claim 53, wherein the removable portion comprises the main panel.
57. The blank of claim 53, further comprising a tab extending from an end of at least one of the first minor panel and the second minor panel.
58. The blank of claim 53, wherein at least one of the first minor panel and the second minor panel has a first dimension that is greater than the first dimension of the main panel.
59. The blank of claim 53, further comprising a substantially lentiform end panel joined to the main panel along a substantially arcuate fold line.

60. The blank of claim 53, further comprising
a first partial end panel joined to the first major panel along a first curved fold line; and
a second partial end panel joined to the second major panel along a second curved fold line.

61. The blank of claim 53, formed into a sleeve for heating, browning, and/or crisping a food item in a microwave oven, wherein
the main panel is a first main panel,
the end panel is a first end panel,
the first major panel and the second major panel overlap to form a second main panel,
the first main panel is substantially parallel to the second main panel,
the first minor panel is substantially parallel to the second minor panel,
the first main panel, the second main panel, the first minor panel, and the second minor panel define an interior surface, and
the microwave energy interactive element overlies at least a portion of the interior surface.

62. The blank of claim 53, formed into a sleeve for heating, browning, and/or crisping a food item in a microwave oven, wherein
the main panel is a first main panel,
the end panel is a first end panel,
the first major panel and the second major panel overlap to form a second main panel,
the first main panel is substantially parallel to the second main panel,

the first minor panel is substantially parallel to the second minor panel,
and

the first main panel, the second main panel, the first minor panel, and
the second minor panel define a cavity for receiving a food item therein,

the microwave energy interactive element comprises a susceptor; and

the sleeve includes a removable portion comprising the removable
portion of the blank.

63. A blank for forming a construct, comprising:

a plurality of adjoined panels, each having a first dimension extending in
a first direction and a second dimension extending in a second direction, the
first direction being substantially perpendicular to the second direction;

a microwave energy interactive element overlying at least a portion of at
least one of the adjoined panels; and

a removable portion defined by a line of disruption initiating and
terminating proximate a peripheral edge extending in the second direction
along the blank.

64. The blank of claim 63, wherein the line of disruption comprises a cut
line, a score line, a kiss cut line, a perforated line, a zigzag cut line, a zipper cut
line, or any combination thereof.

65. The blank of claim 63, wherein the microwave energy interactive
element comprises a susceptor, a foil, a segmented foil, or any combination
thereof.

66. The blank of claim 63, wherein the plurality of adjoined panels includes
a main panel,
a first minor panel joined to the main panel,

a second minor panel joined to the main panel,
a first major panel joined to the first minor panel, and
a second major panel joined to the second minor panel,
wherein the main panel, the first minor panel, the second minor panel,
the first major panel, and the second major panel are joined respectively to one
another along respective substantially parallel fold lines extending in the first
direction.

67. The blank of claim 66, wherein the removable portion includes at least a
portion of the main panel.

68. The blank of claim 66, wherein the line of disruption that defines the
removable portion initiates and terminates along the peripheral edge of the
blank adjacent the main panel.

69. The blank of claim 66, further comprising a substantially lentiform end
panel joined to the main panel along a substantially arcuate fold line.

70. The blank of claim 69, wherein at least a portion of the line of disruption
extends into the end panel.

71. The blank of claim 70, wherein the portion of the line of disruption that
extends into the end panel defines a tab.

72. The blank of claim 66, further comprising:
a first partial end panel joined to the first major panel along a first
curved fold line; and
a second partial end panel joined to the second major panel along a
second curved fold line.

73. The blank of claim 66, formed into a sleeve for heating, browning, and/or crisping a food item in a microwave oven, wherein

- the main panel is a first main panel,
- the end panel is a first end panel,
- the first major panel and the second major panel overlap to form a second main panel,
- the first main panel is substantially parallel to the second main panel,
- the first minor panel is substantially parallel to the second minor panel,
- the first main panel, the second main panel, the first minor panel, and the second minor panel define an interior surface, and
- the microwave energy interactive element overlies at least a portion of the interior surface.

74. The blank of claim 73, wherein the microwave energy interactive element comprises a susceptor.

75. A sleeve for heating, browning, and/or crisping a food item therein, comprising:

- a first main panel and a second main panel in an opposed configuration;
- a first minor panel and a second minor panel in an opposed configuration, the first minor panel and the second minor panel being joined to the first main panel and the second main panel along respective fold lines to define at least partially an interior surface;

- a microwave energy interactive element overlying at least a portion of the interior surface; and

- a removable portion comprising at least a portion of at least one of the first main panel, the second main panel, the first minor panel, and the second minor panel.

76. The sleeve of claim 75, wherein the microwave energy interactive element comprises a susceptor, a foil, a segmented foil, or any combination thereof.

77. The sleeve of claim 75, further comprising:
a first end panel extending from a first end of the first main panel; and
a second end panel extending from a first end of the second main panel,
wherein the first end panel and the second end panel are in a substantially aligned, opposed, facing relation.

78. The sleeve of claim 75, wherein the removable portion is defined at least partially by a line of disruption extending in the second direction across at least a portion of at least one of the first main panel, the second main panel, the first minor panel, and the second minor panel.

79. The sleeve of claim 75, where the removable portion is defined at least partially by an oblique tear line at least partially disposed within the first main panel, and a transverse tear line extending in the second direction across at least a portion of the first main panel.

80. The sleeve of claim 75, wherein the removable portion is defined at least partially by a line of disruption extending obliquely across at least one of the first main panel, the second main panel, the first minor panel, and the second minor panel.

81. The sleeve of claim 75, wherein the removable portion is defined by at least one tear line that extends in the first direction and adjoins
at least one of the first main panel and the second main panel to

at least one of the first minor panel and the second minor panel.

82. The sleeve of claim 75, wherein
each of the adjoined panels has a first end, and
the removable portion is defined by a line of disruption initiating and
terminating proximate the first end of at least one of the adjoined panels.
83. The sleeve of claim 82, wherein the line of disruption initiates and
terminates proximate the first end of the first main panel.
84. The sleeve of claim 82, wherein
the plurality of panels further includes an end panel extending from the
second end of the first main panel, and
the line of disruption initiates proximate the first end of the first main
panel, extends into the end panel, and terminates proximate the first end of the
first main panel.
85. A container for supporting a food item therein, comprising:
a first main panel and a second main panel in an opposed configuration;
a first minor panel and a second minor panel in an opposed
configuration, the first minor panel and the second minor panel being joined to
the first main panel and the second main panel along respective fold lines to
define an interior space;
a pair of end panels folded along respective substantially arcuate fold
lines toward the interior space in a superposed configuration; and
a removable portion comprising at least a portion of the first main panel,
the second main panel, the first minor panel, and the second minor panel.

86. The container of claim 85, further comprising a microwave energy interactive element overlying at least a portion of at least one of the first main panel, the second main panel, the first minor panel, and the second minor panel.

87. The container of claim 85, wherein the removable portion is defined at least partially by a line of disruption extending in the second direction across at least a portion of at least one of the first main panel, the second main panel, the first minor panel, and the second minor panel.

88. The container of claim 85, wherein
the removable portion is a first removable portion,
the line of disruption is a first line of disruption,
the container further comprises a second removable portion defined at least partially by a second line of disruption extending in the second direction at least partially across at least one of first main panel, the second main panel, the first minor panel, and the second minor panel, and
the first line of disruption is substantially parallel to the second line of disruption.

89. The container of claim 85, wherein the removable portion is defined at least partially by

an oblique tear line, and

a transverse tear line extending in the second direction at least partially across at least one of the first main panel, the second main panel, the first minor panel, and the second minor panel.

90. The container of claim 89, wherein
the removable portion comprises a tab, and

the oblique tear line extends substantially between the tab and the transverse tear line.

91. The container of claim 89, further comprising a cutout disposed between the first main panel and the second main panel.

92. The container of claim 89, wherein the removable portion comprises a tab extending from the first main panel into a cutout disposed between the tab and the second main panel.

93. The container of claim 92, wherein the cutout is disposed at least partially within the second minor panel.

94. The container of claim 92, wherein the cutout is adjacent to the second minor panel.

95. The container of claim 85, wherein the removable portion is defined at least partially by a line of disruption extending obliquely across at least one of the first main panel, the second main panel, the first minor panel, and the second minor panel.

96. The container of claim 85, wherein the removable portion is defined by at least one tear line that extends in the first direction and adjoins

at least one of the first main panel and the second main panel to
at least one of the first minor panel and the second minor panel.

97. The container of claim 85, wherein the removable portion is defined by a line of disruption initiating and terminating proximate a first end of at least one of the adjoined panels.

98. The container of claim 97, wherein the removable portion comprises at least a portion of the first main panel.
99. The container of claim 97, wherein
a first end panel of the pair of end panels extends from a second end of the first main panel, and
the line of disruption extends into the end panel.
100. The container of claim 99, wherein the portion of the line of disruption that extends into the end panel defines a tab.

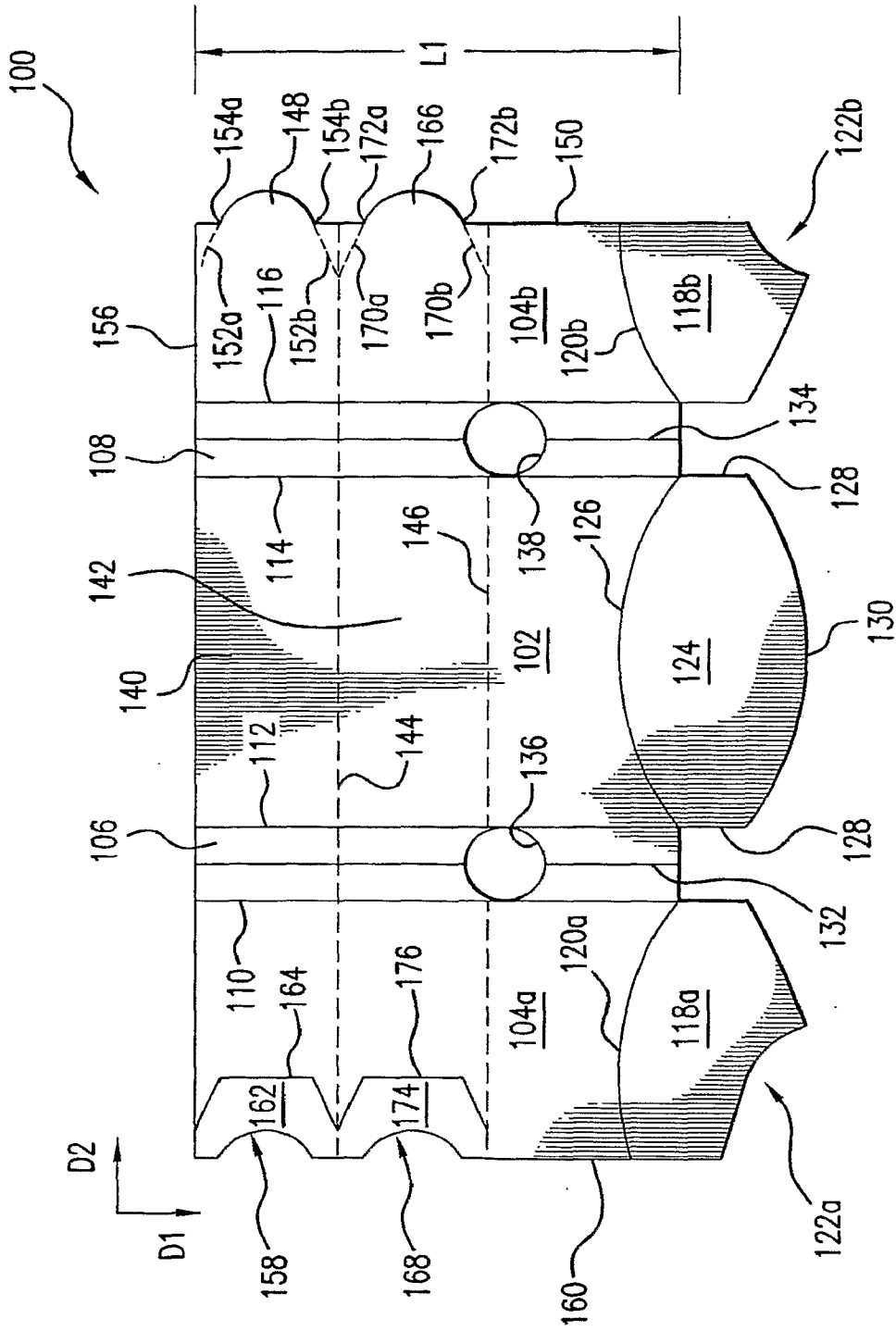

FIG. 1A

2/32

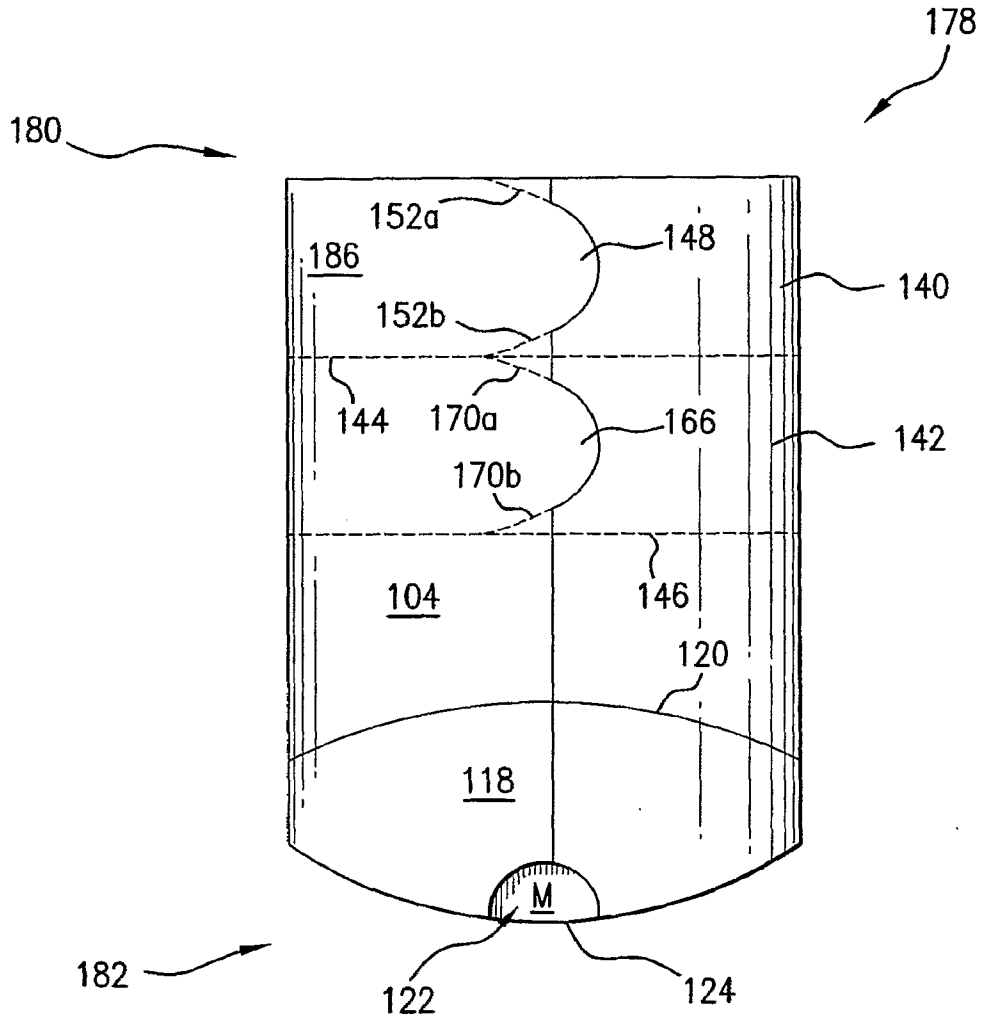

FIG. 1B

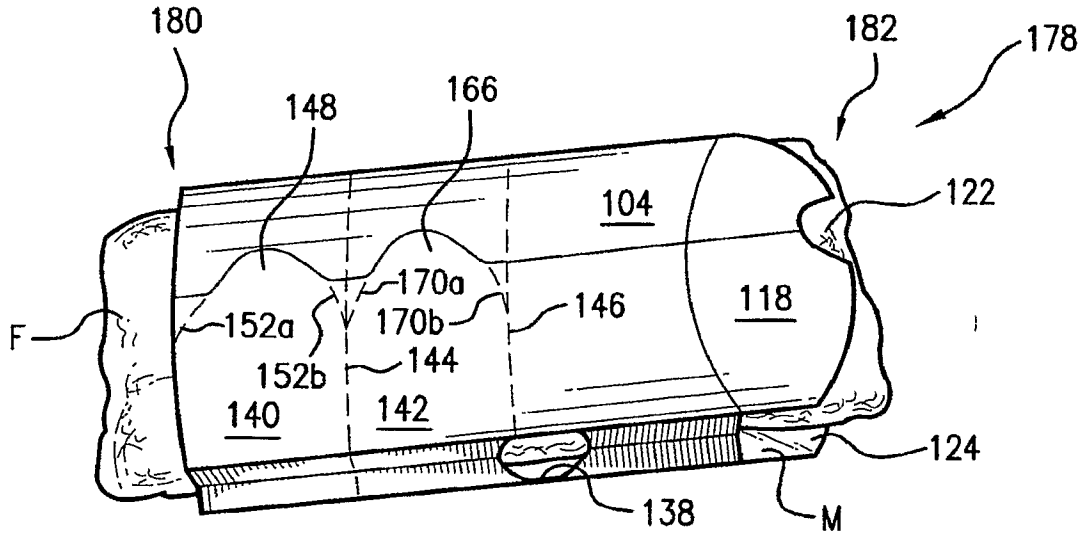

FIG. 1C

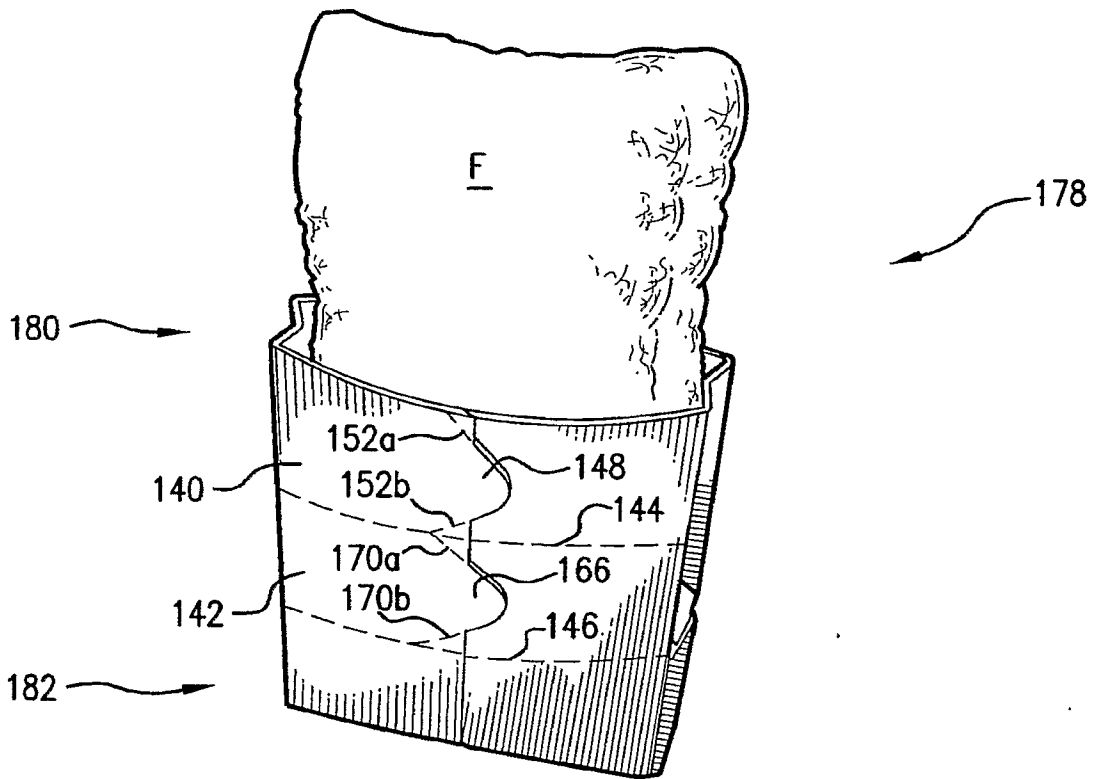
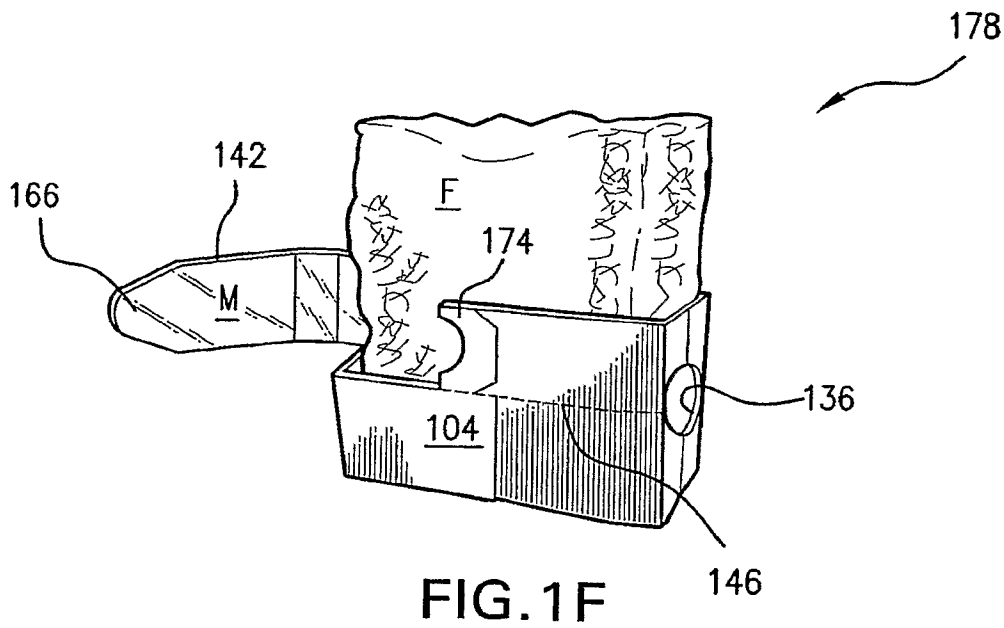
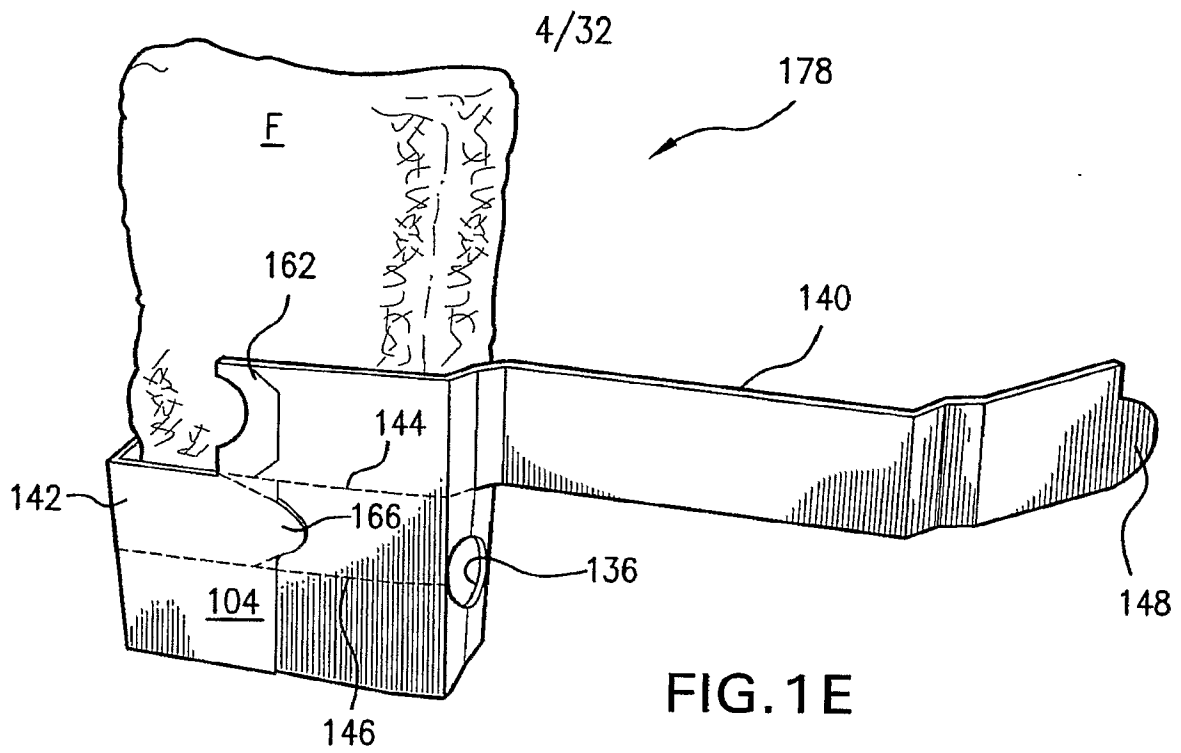

FIG. 1D



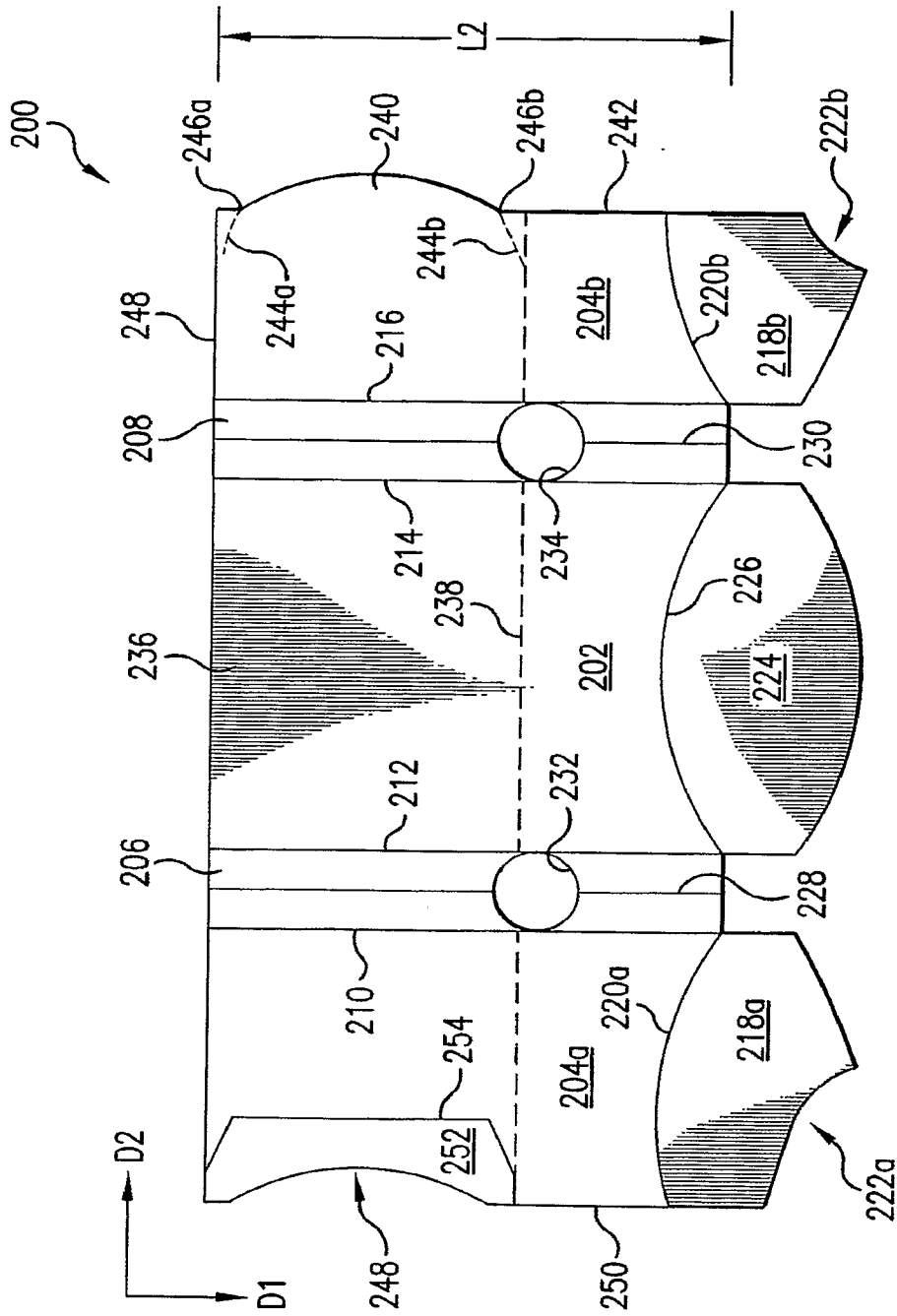

FIG. 2A

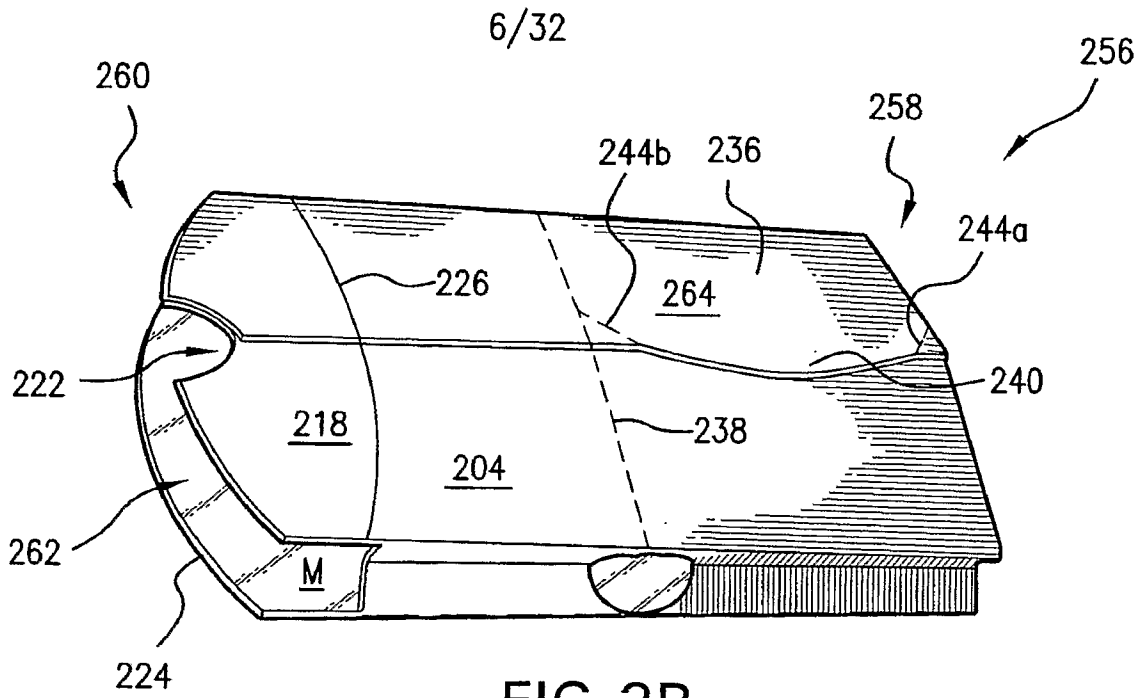

FIG. 2B

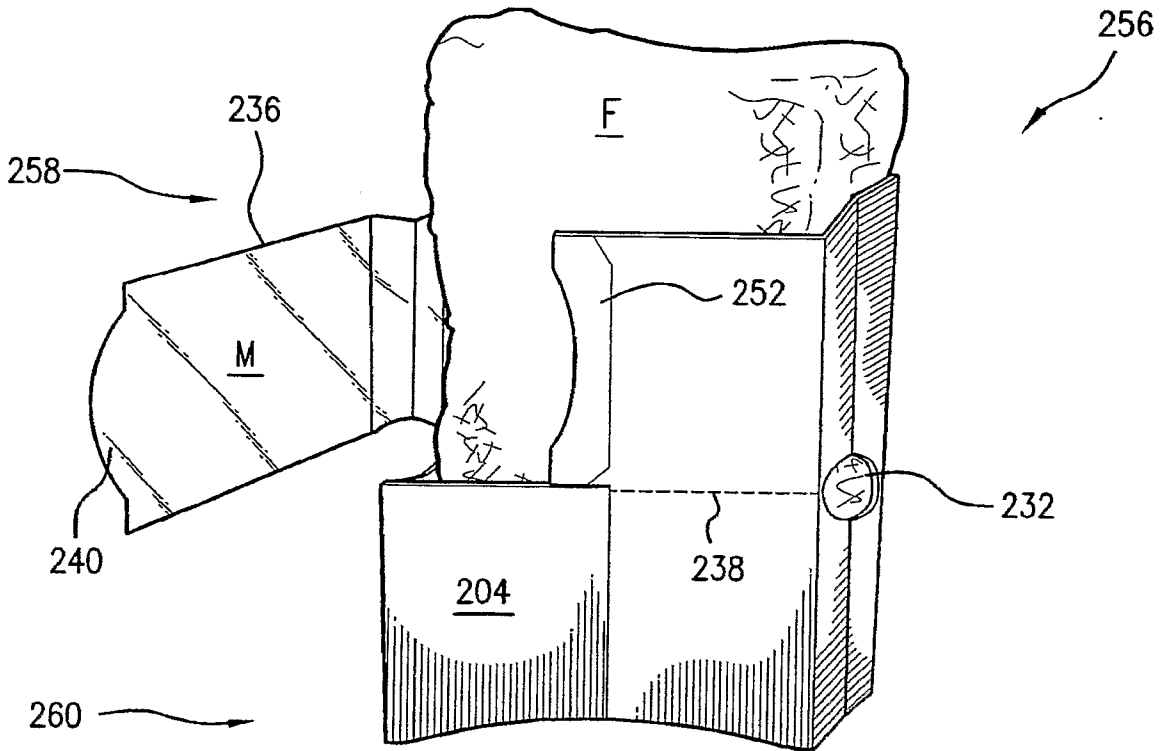

FIG. 2C

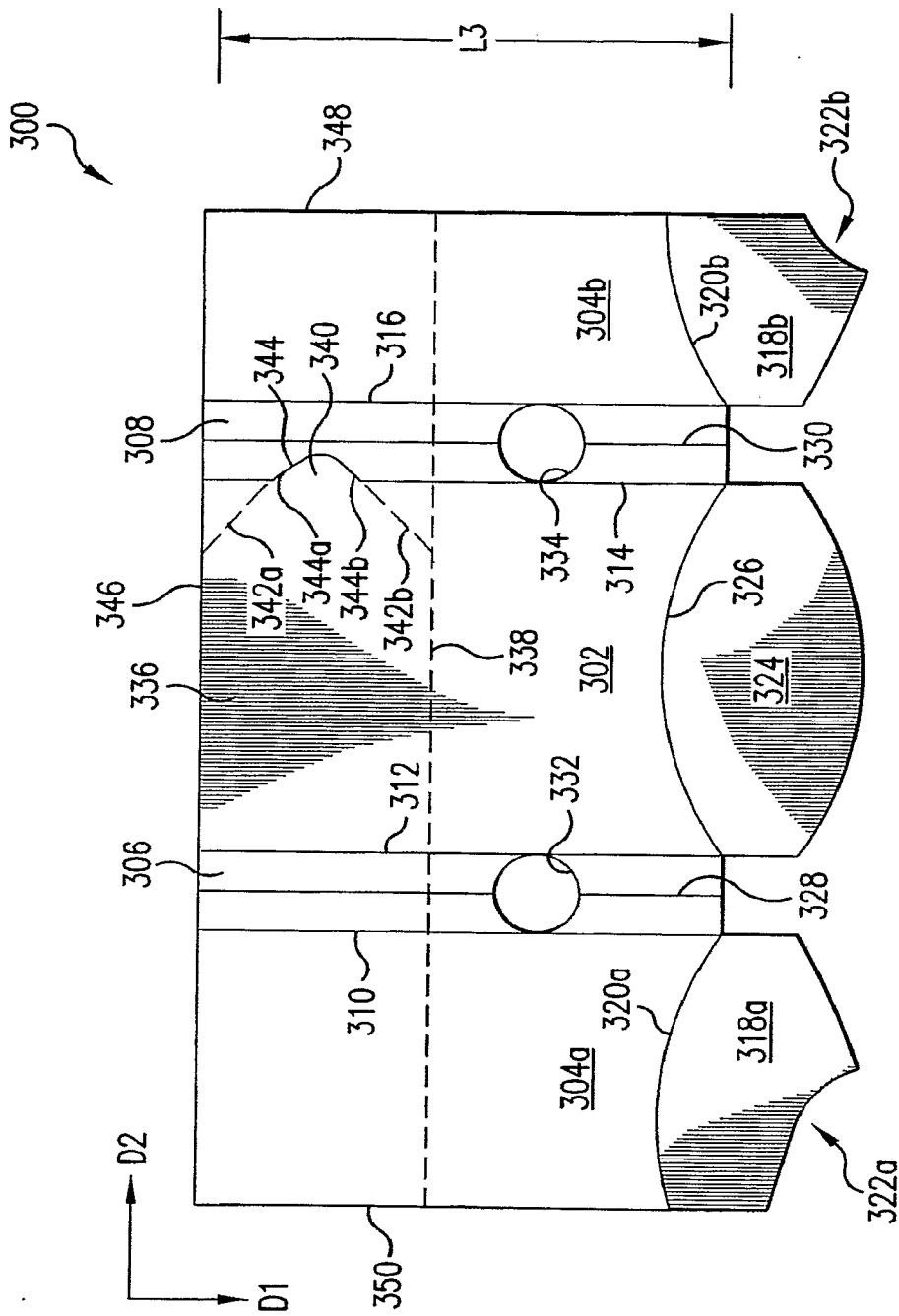

FIG. 3A

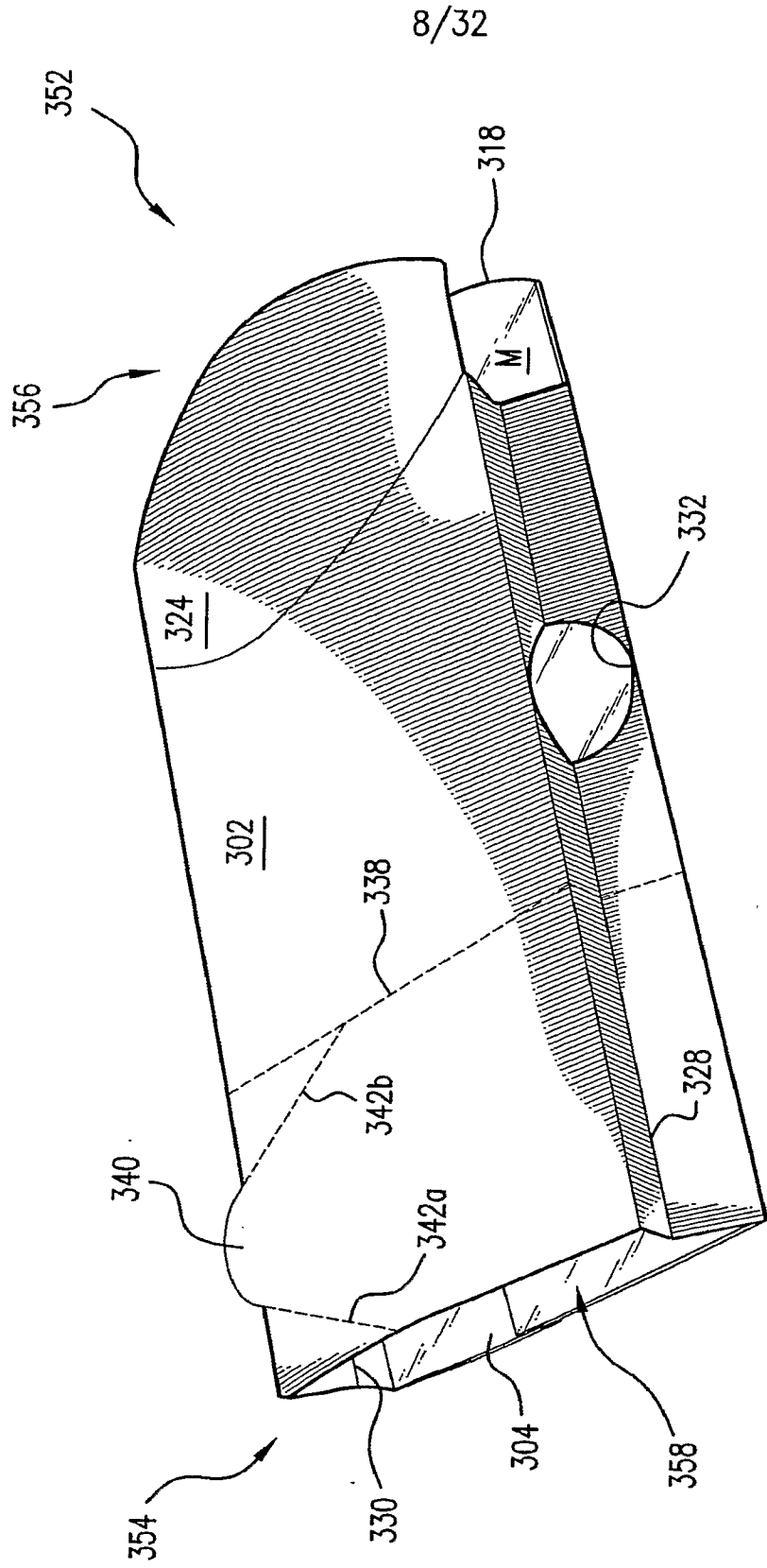

FIG. 3B

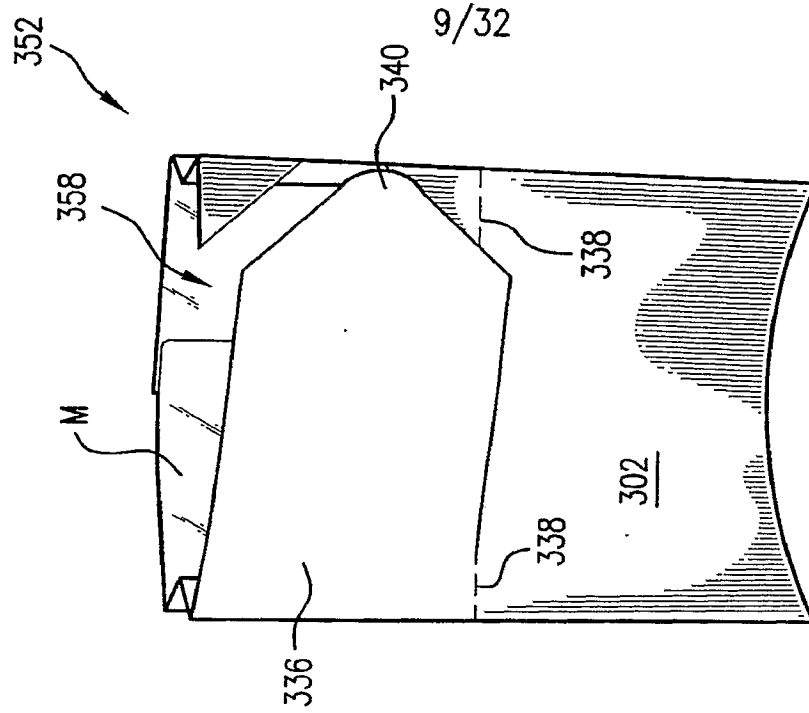

FIG.3D

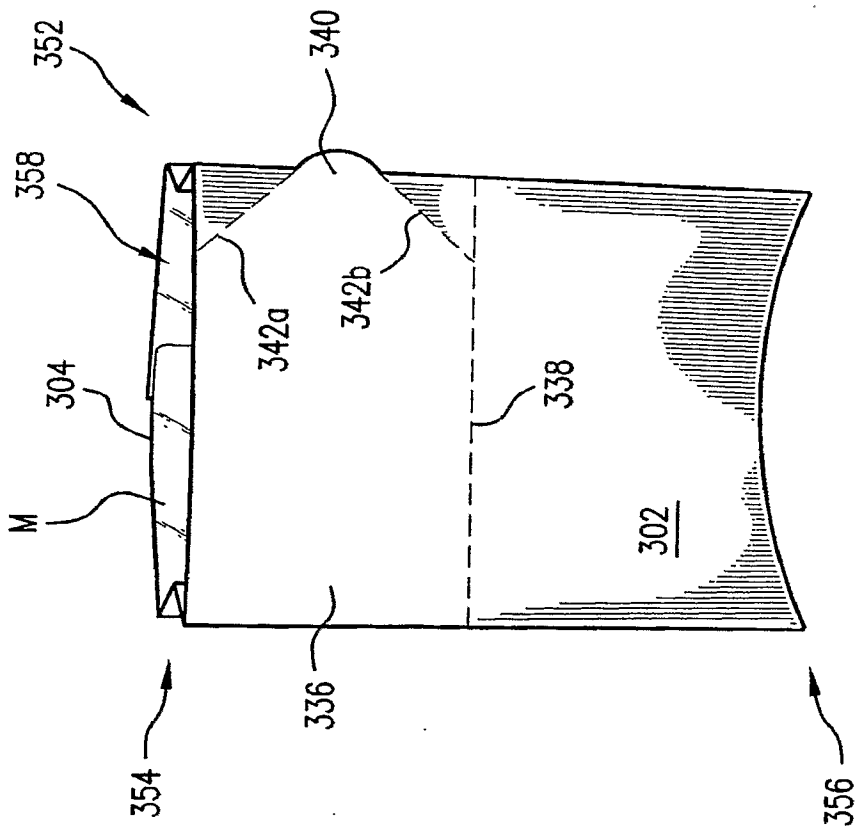

FIG.3C

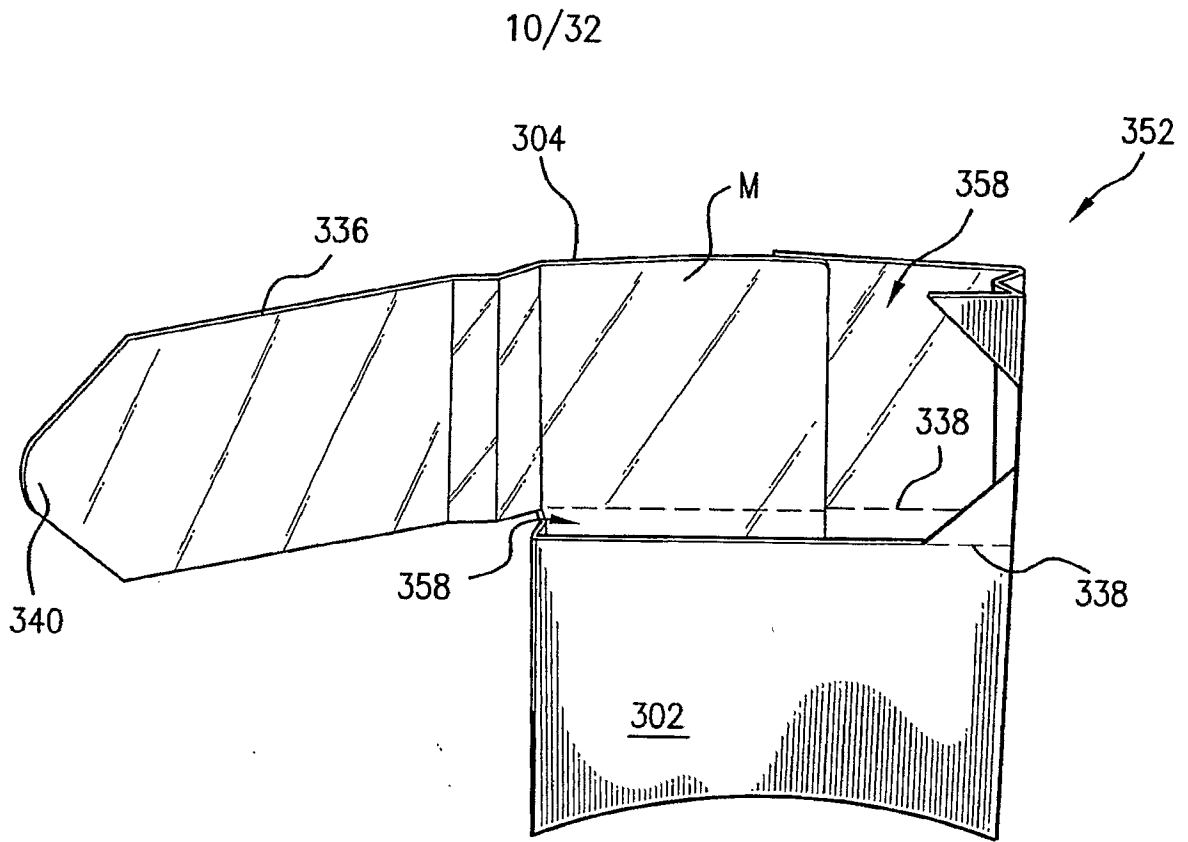

FIG. 3E

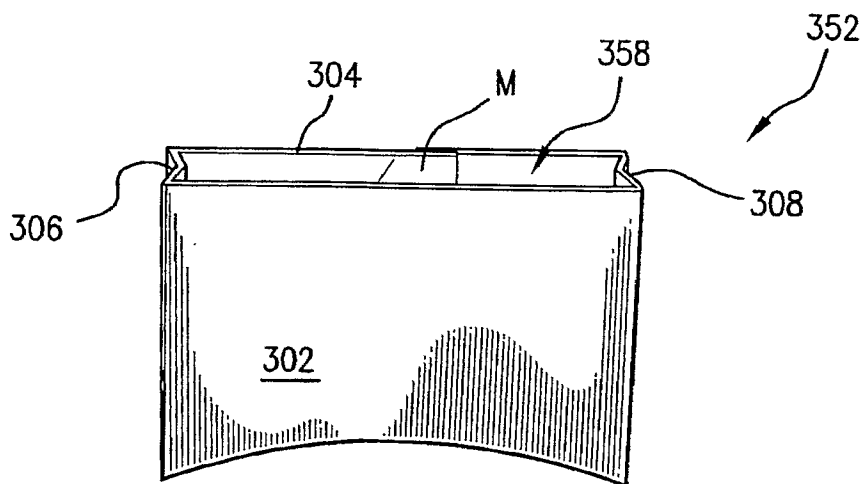

FIG. 3F

11/32

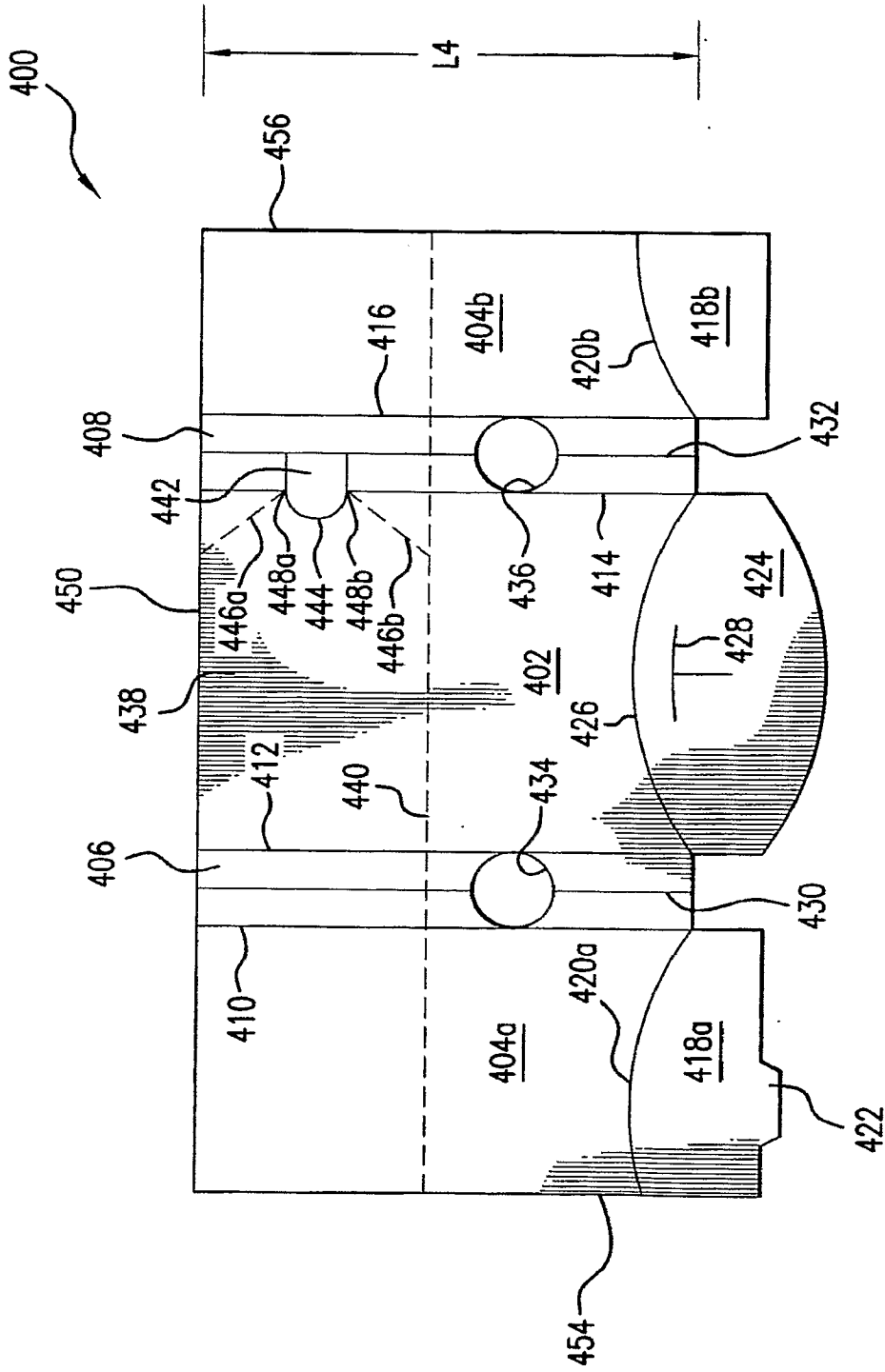

FIG. 4A

12/32

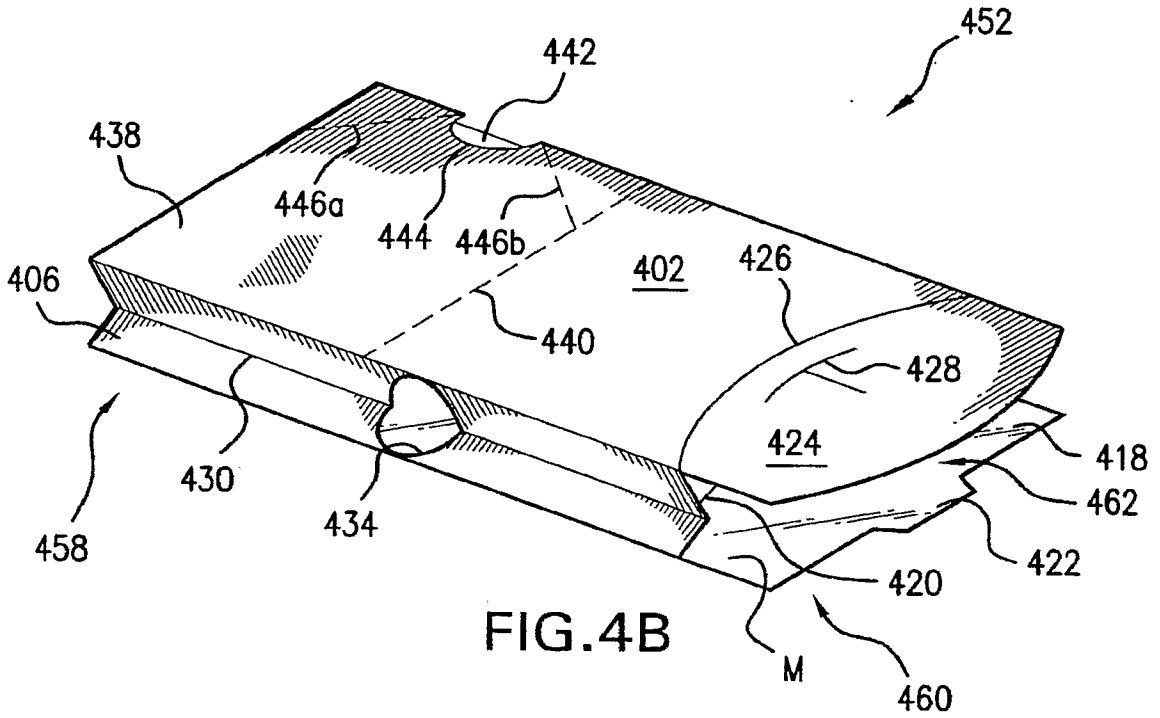

FIG. 4B

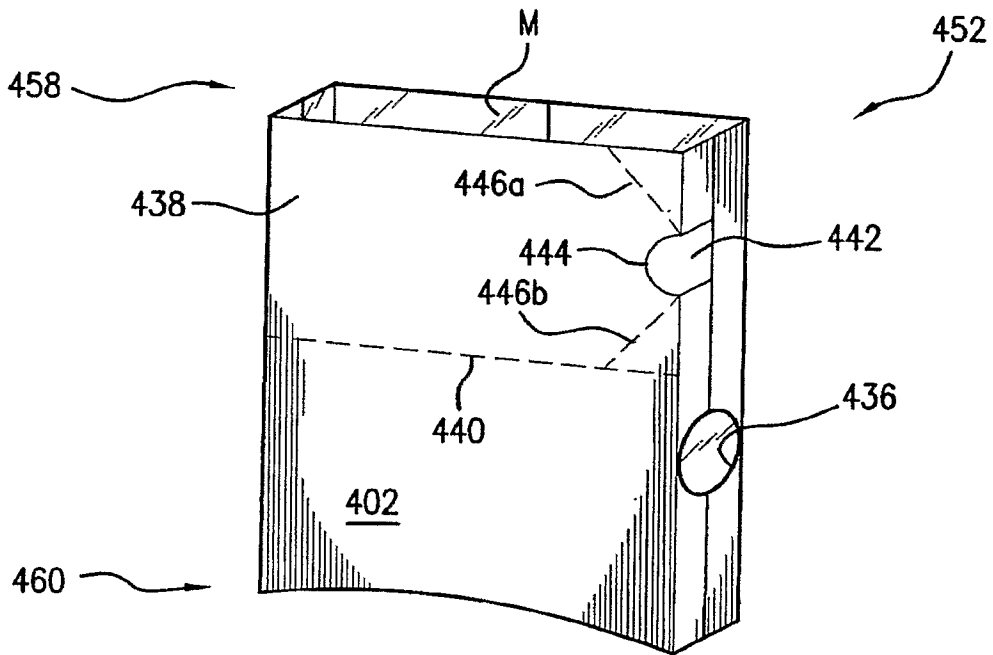

FIG. 4C

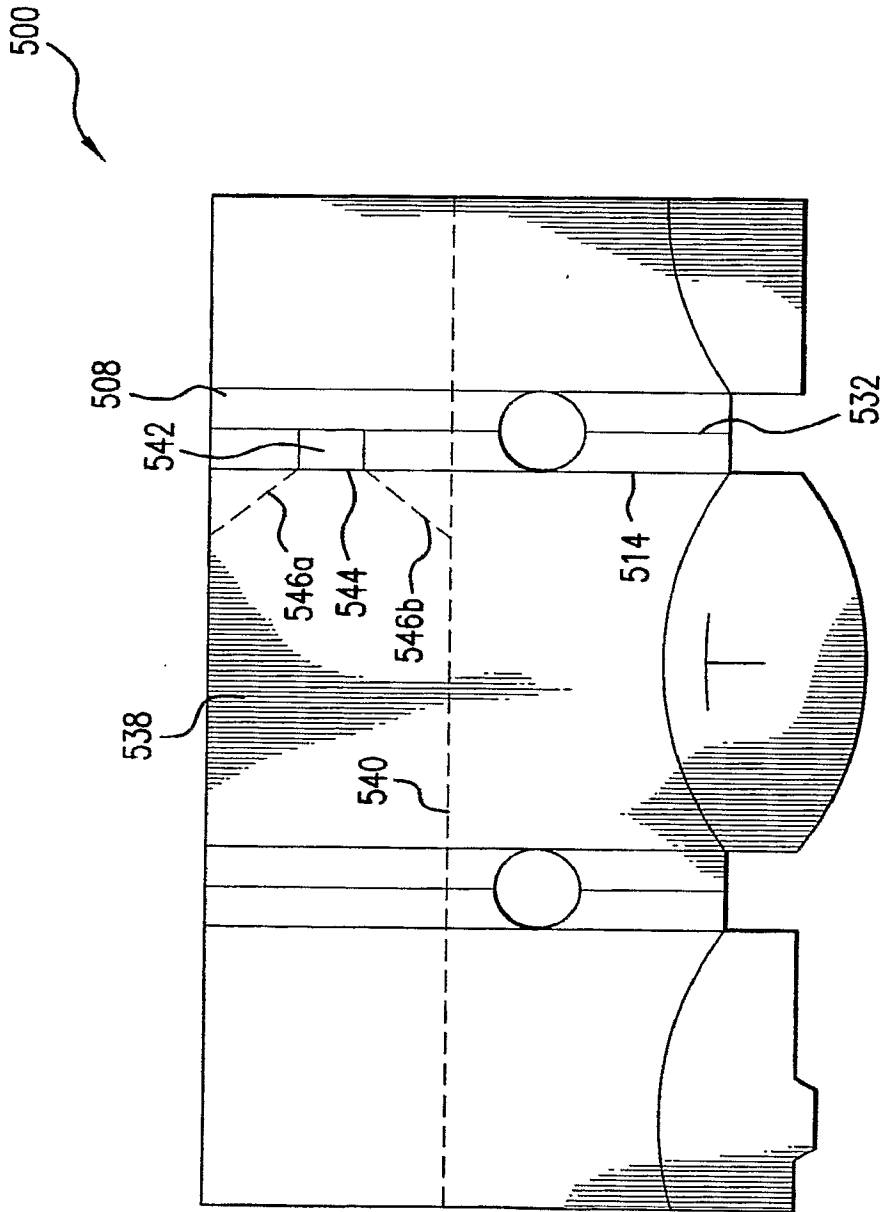

FIG. 5A

14/32

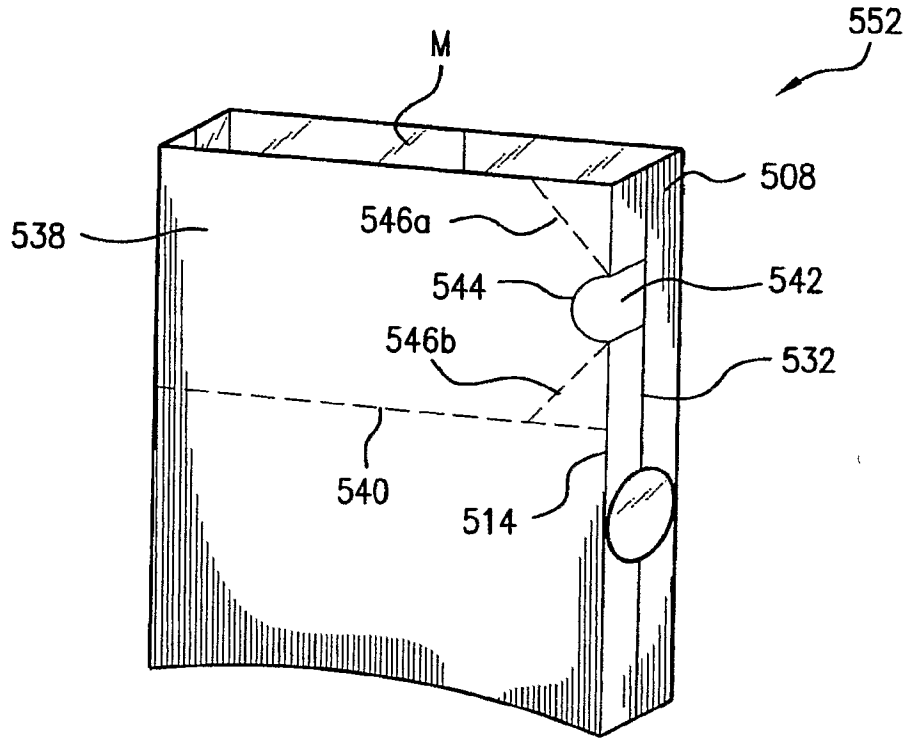

FIG. 5B

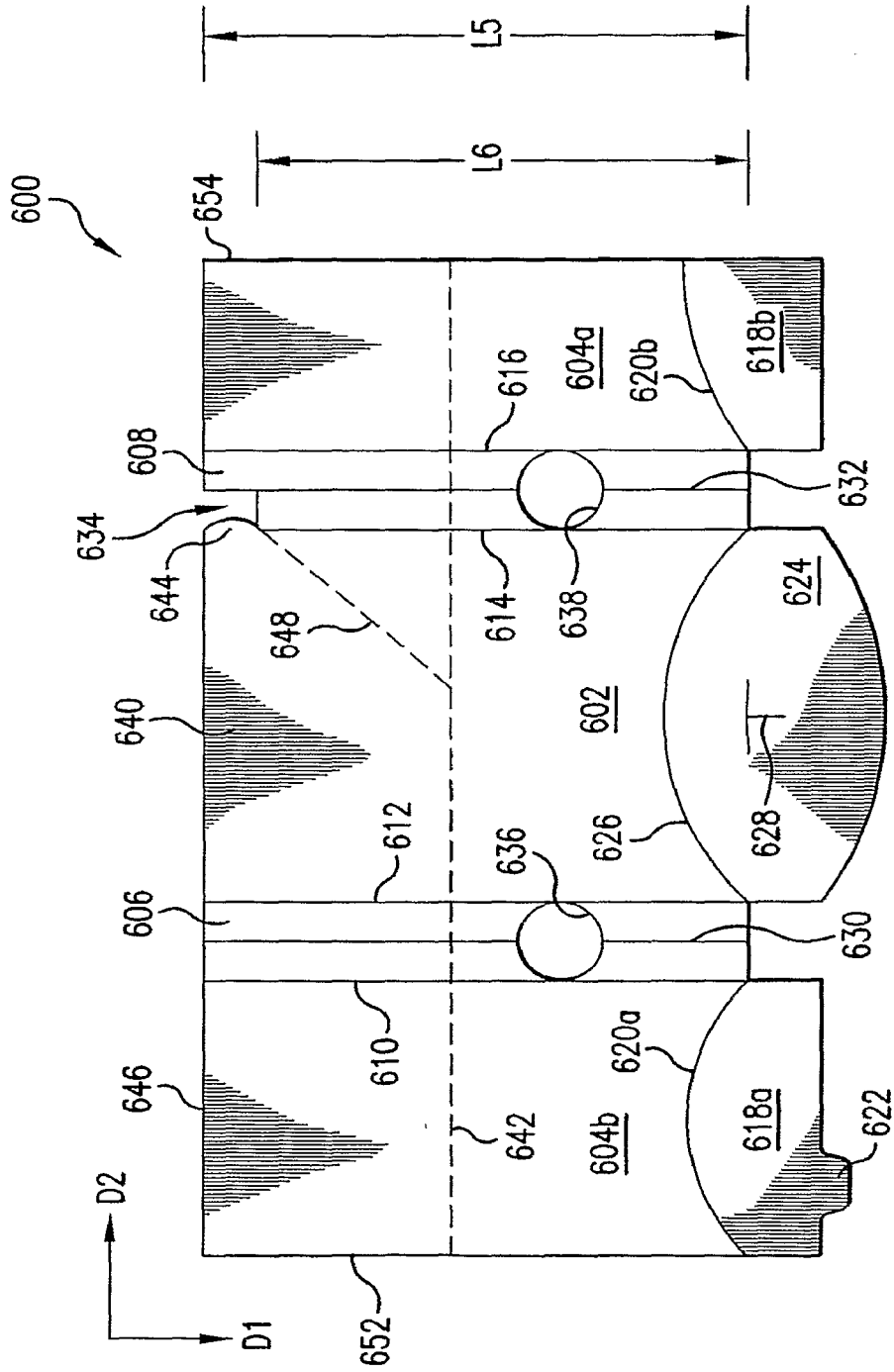
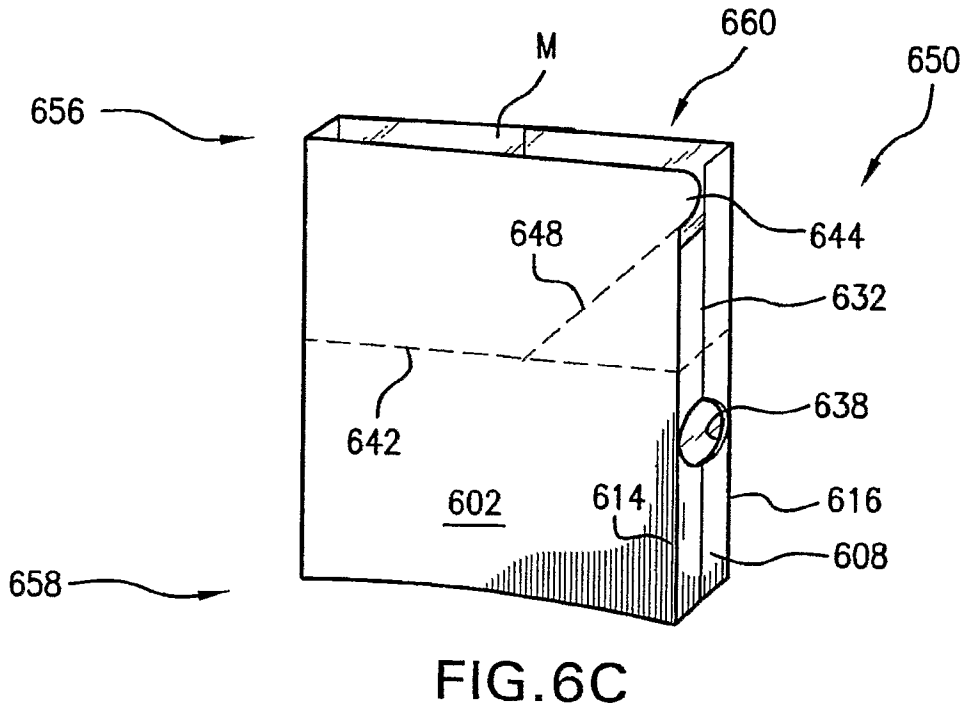
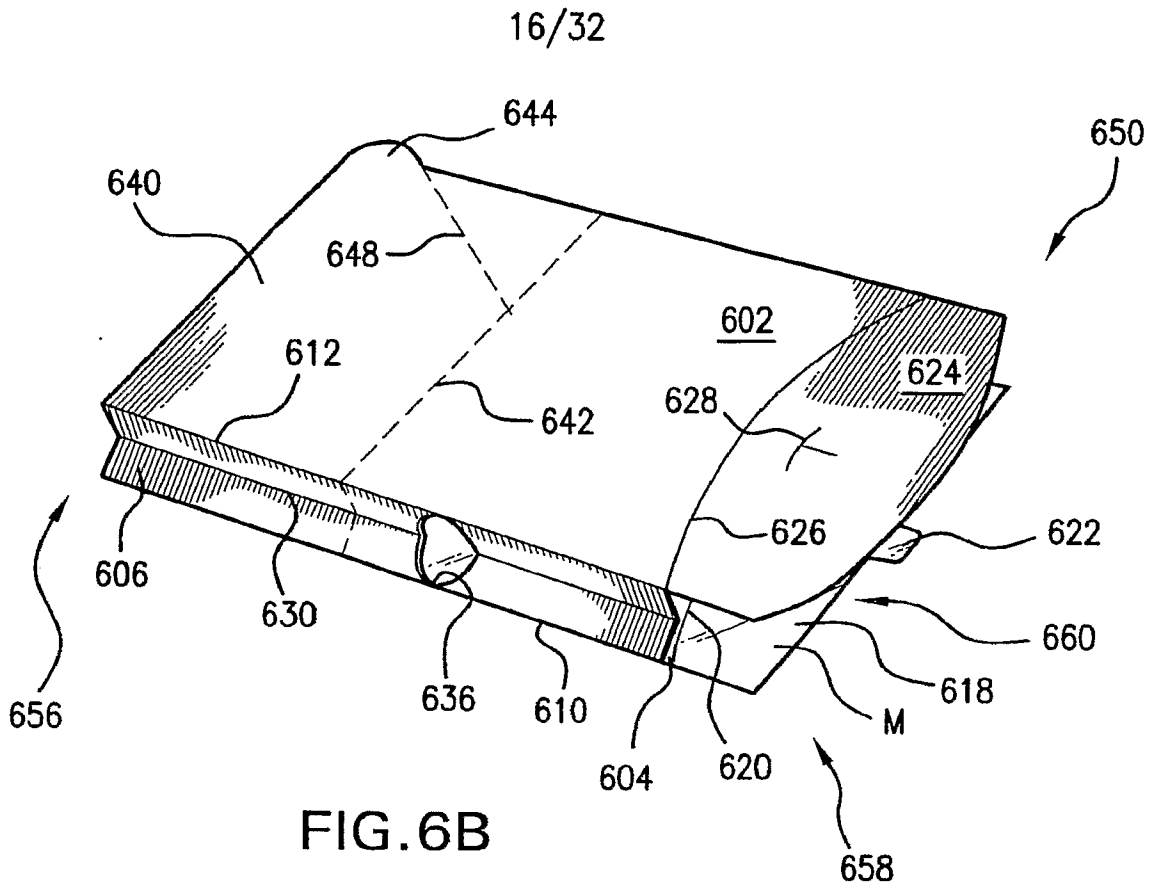

FIG. 6A



17/32

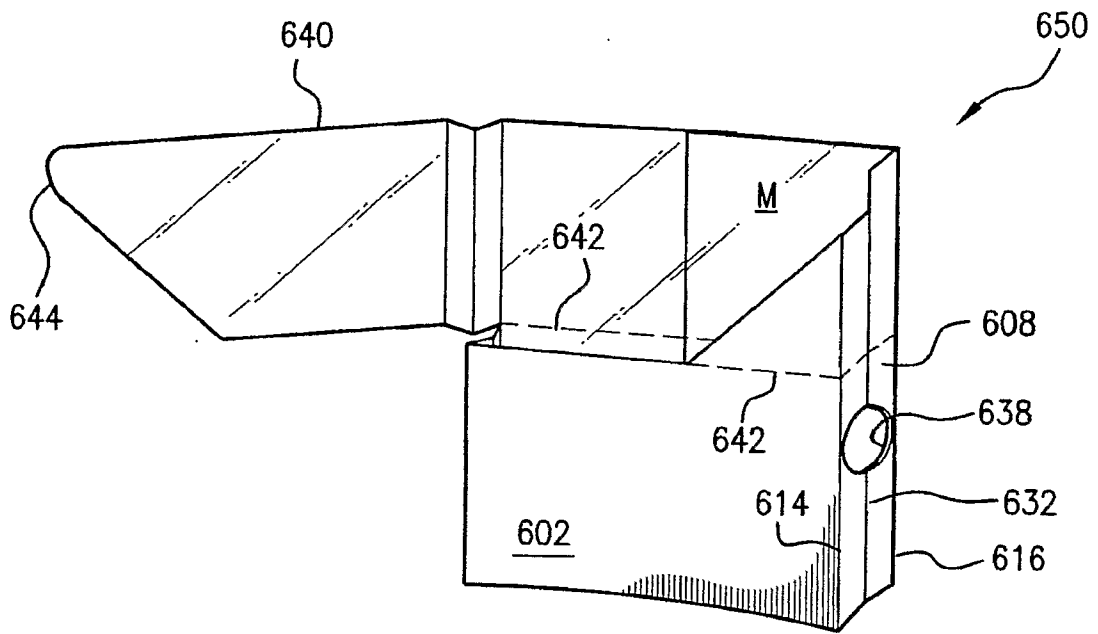

FIG. 6D

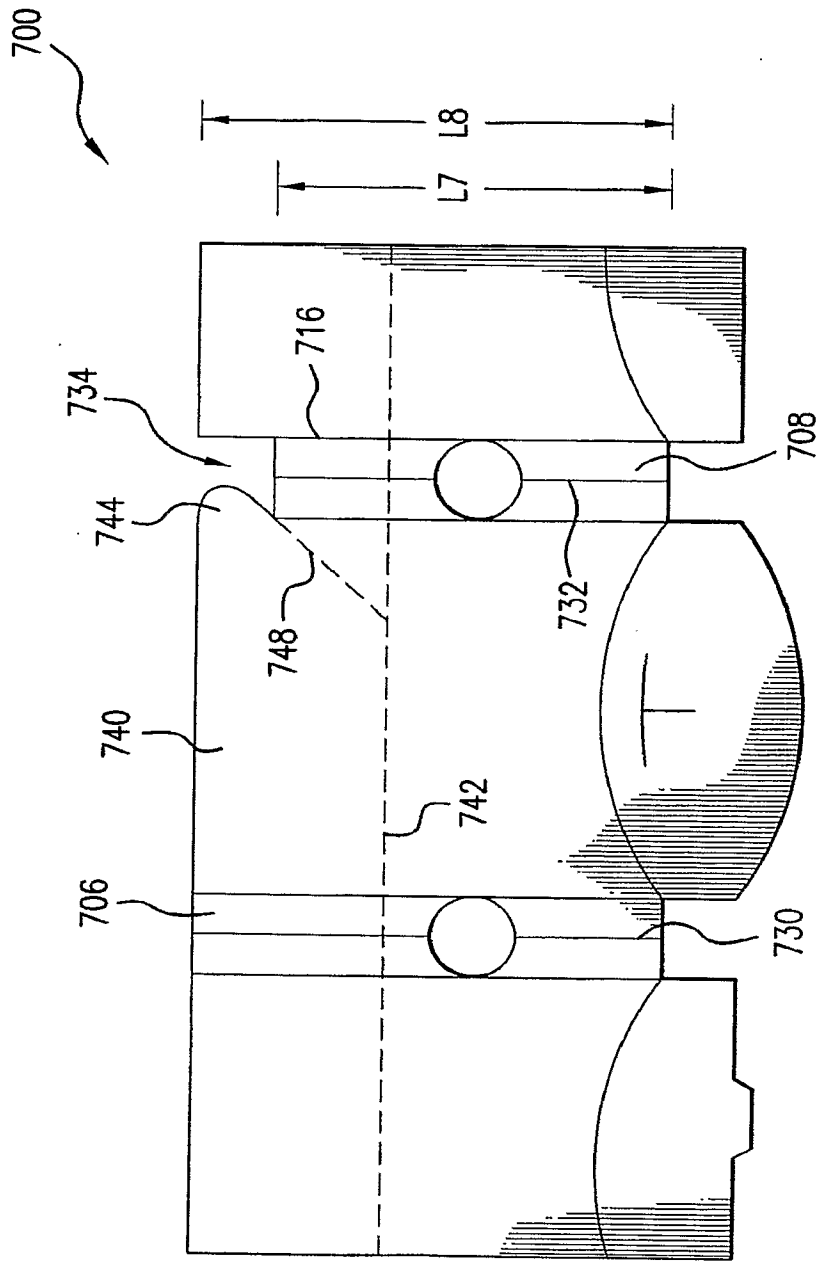

FIG. 7A

19/32

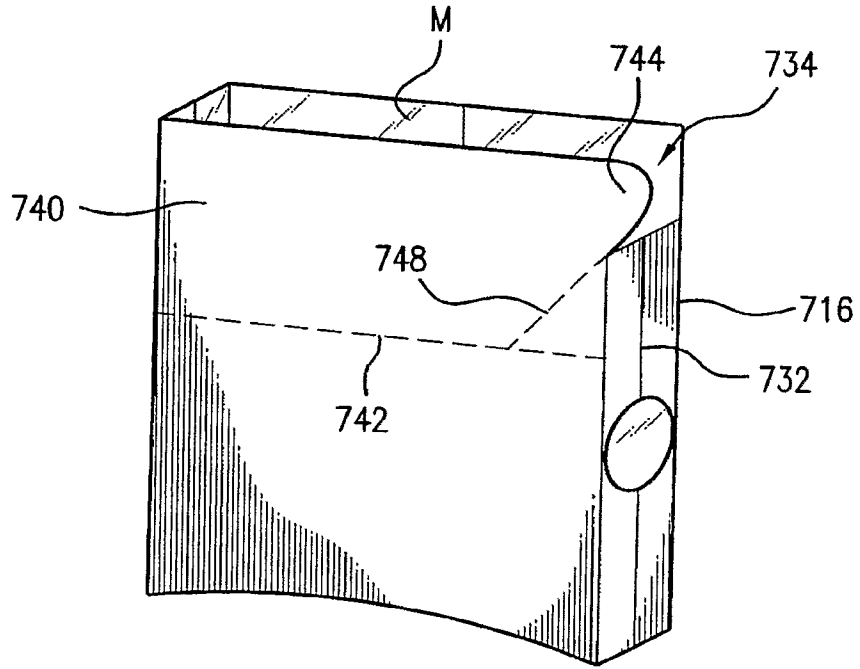

FIG. 7B

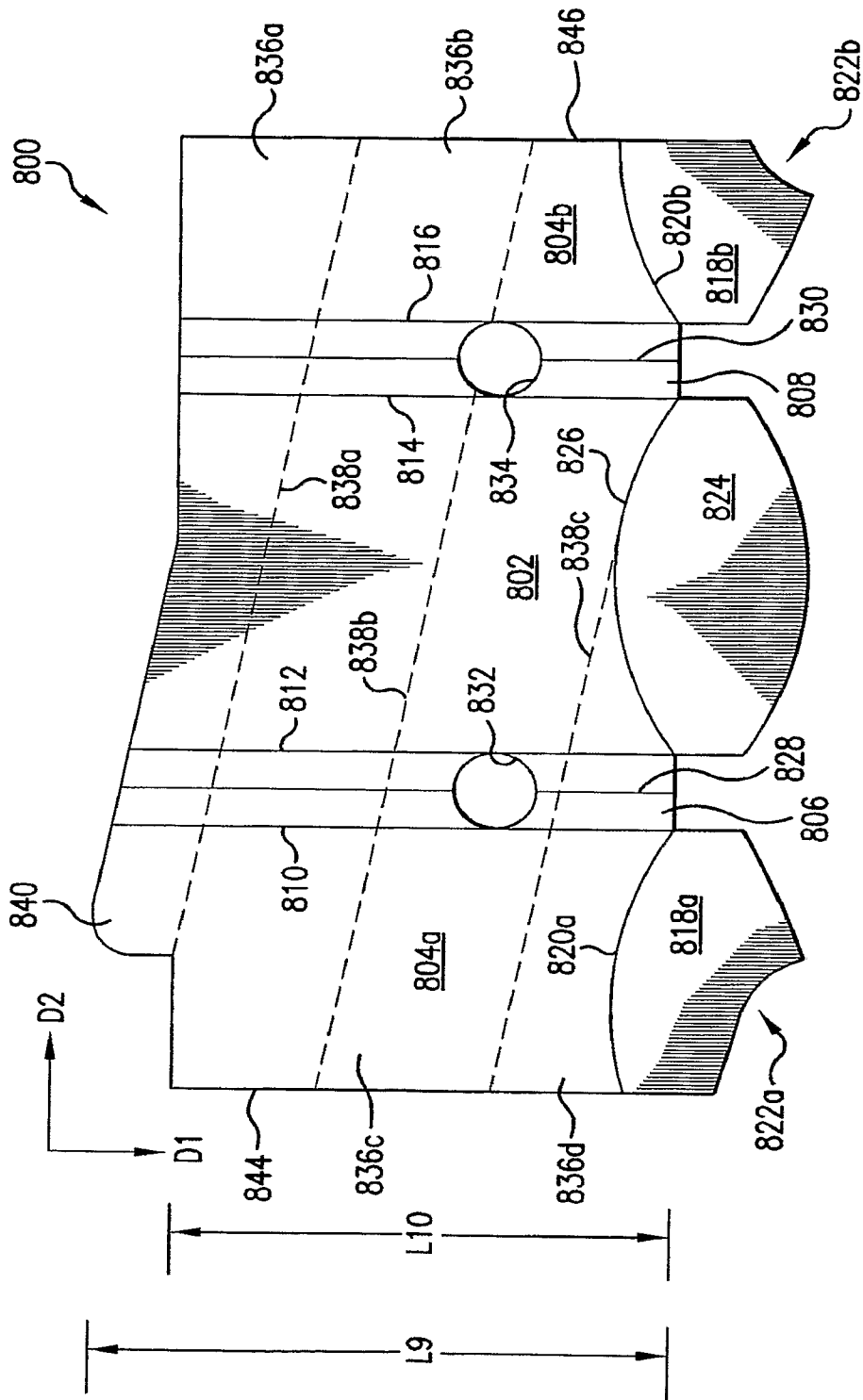

FIG. 8A

21/32

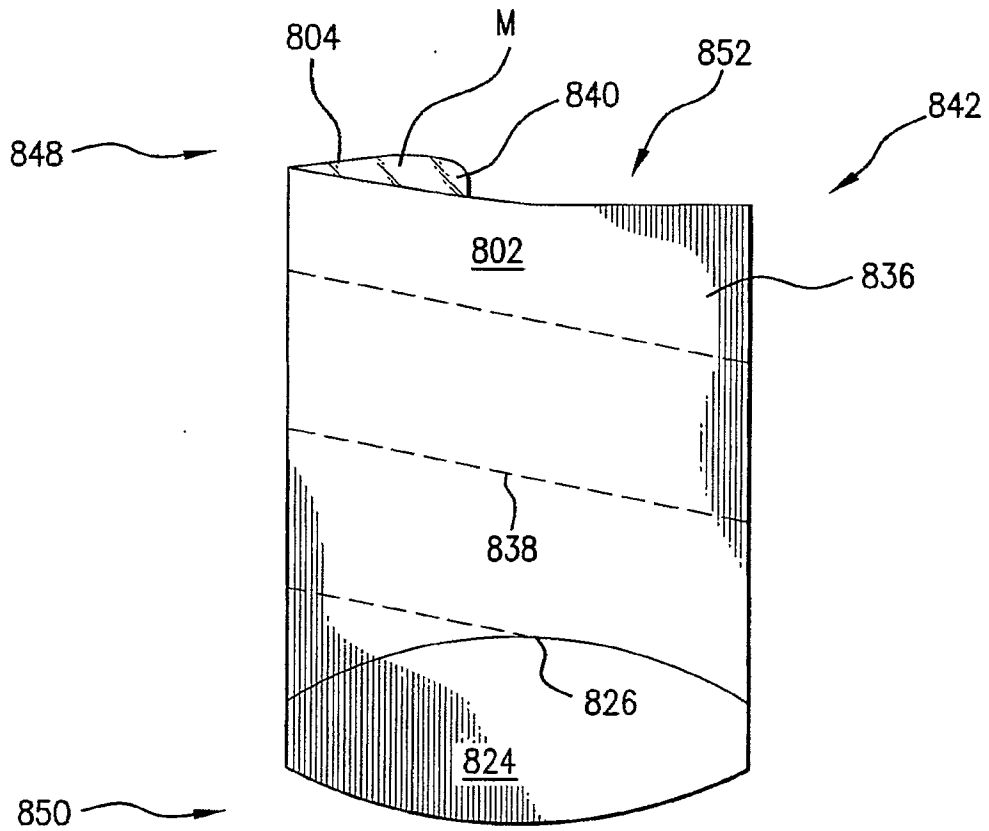

FIG. 8B

22/32

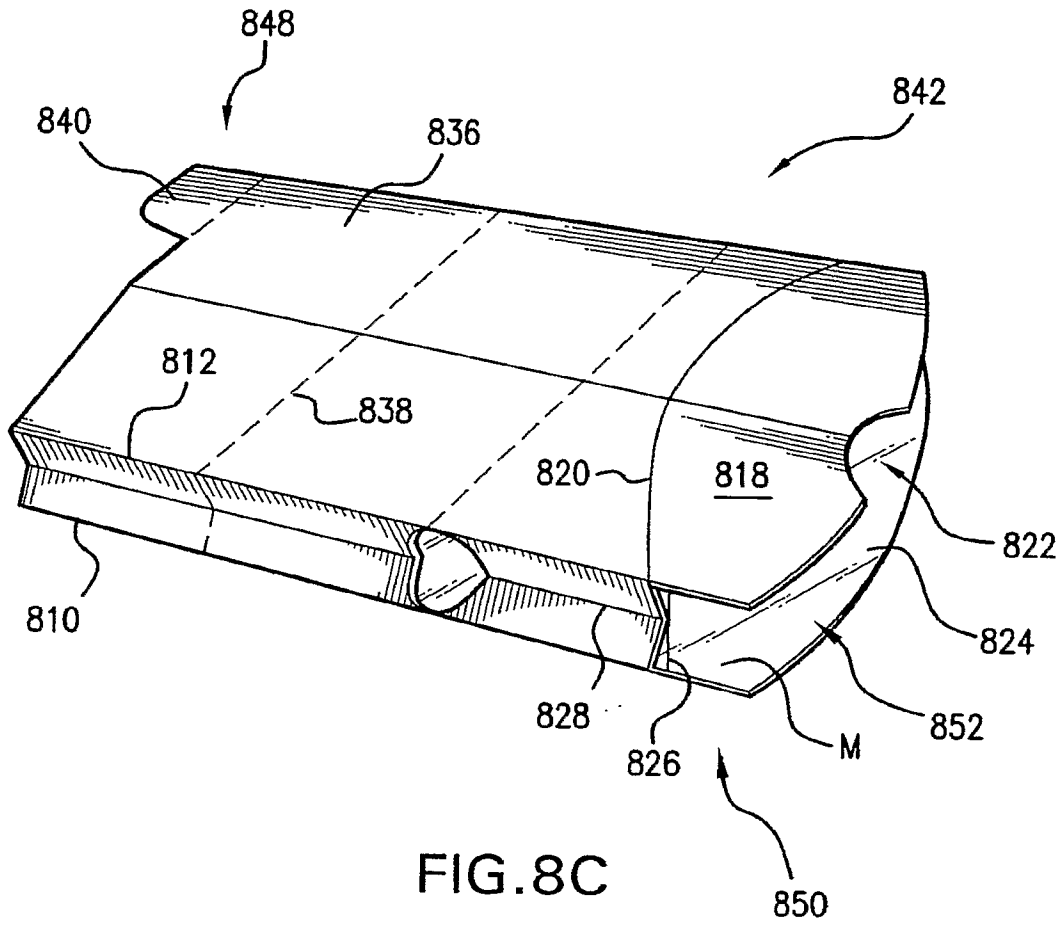

FIG. 8C

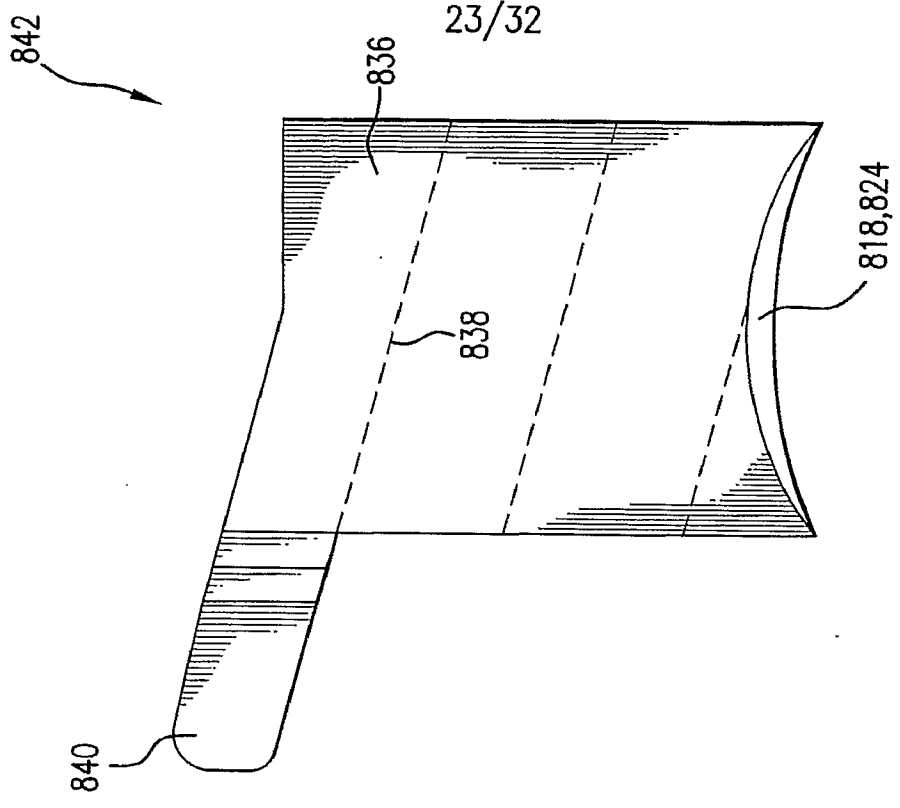

FIG. 8E

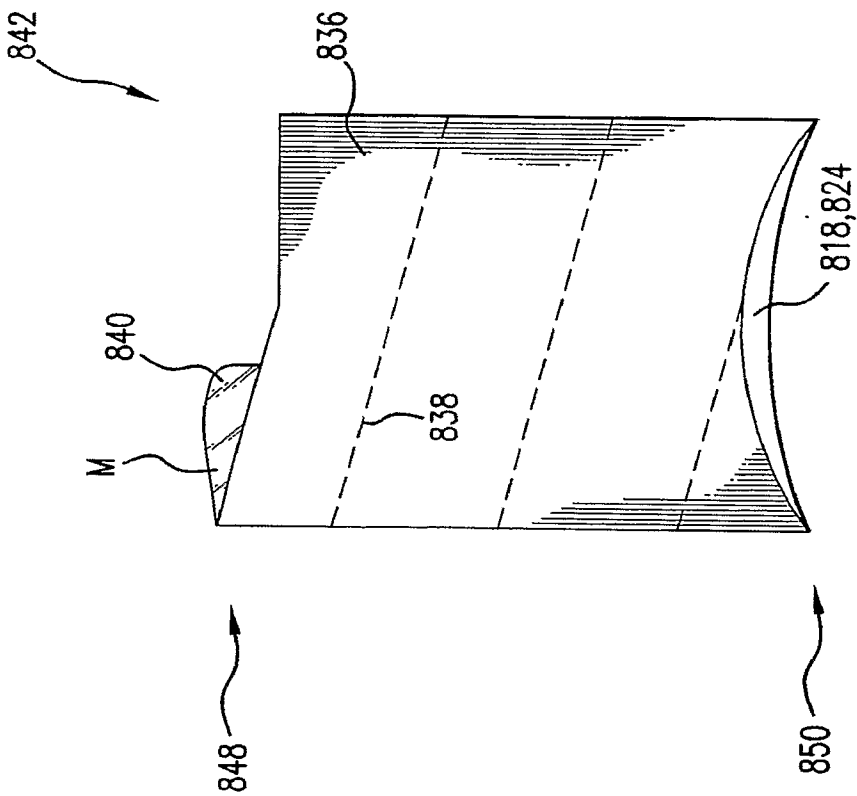

FIG. 8D

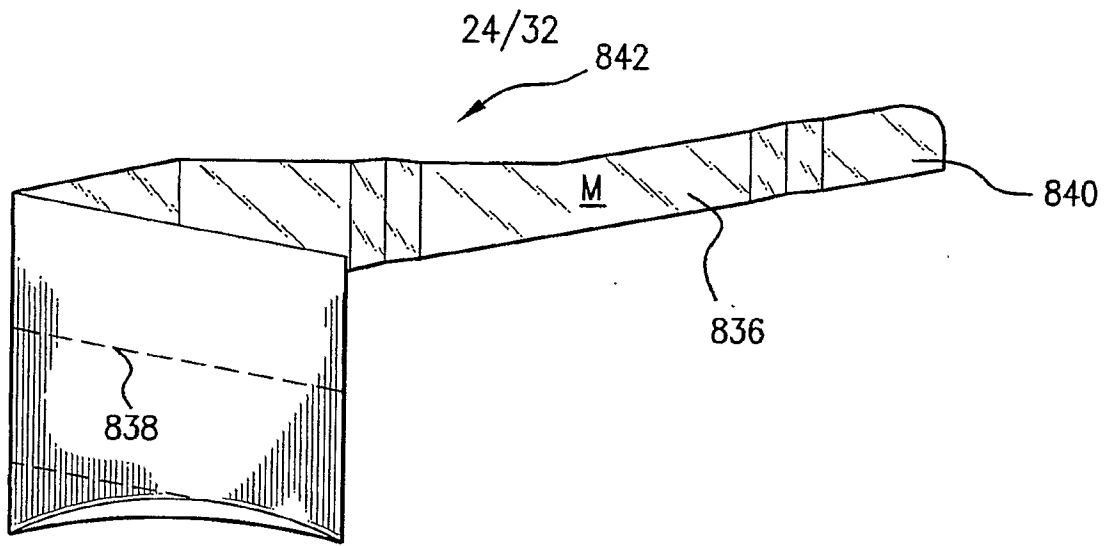

FIG. 8F

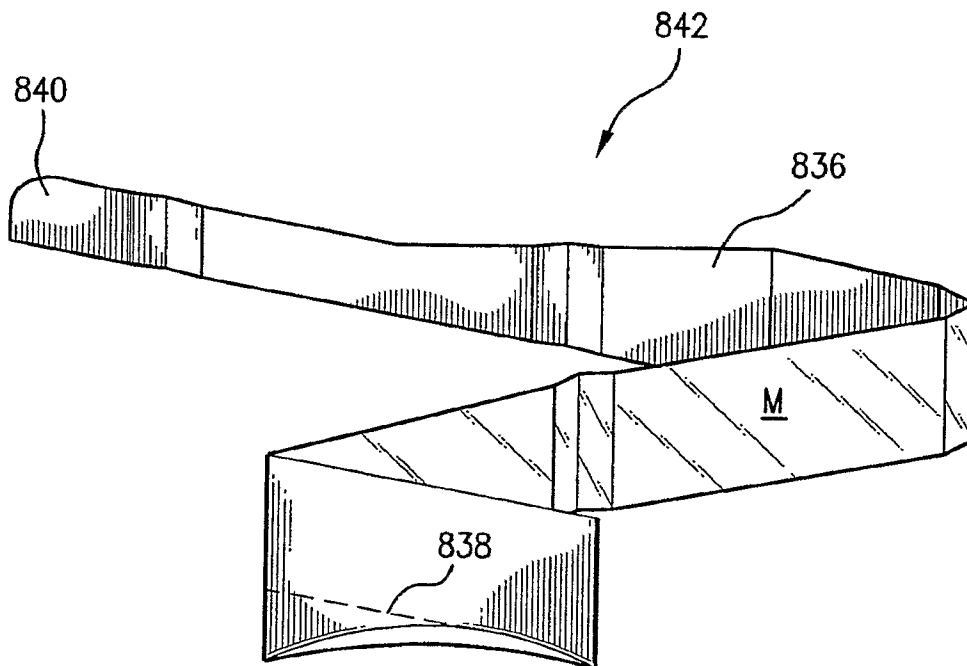

FIG. 8G

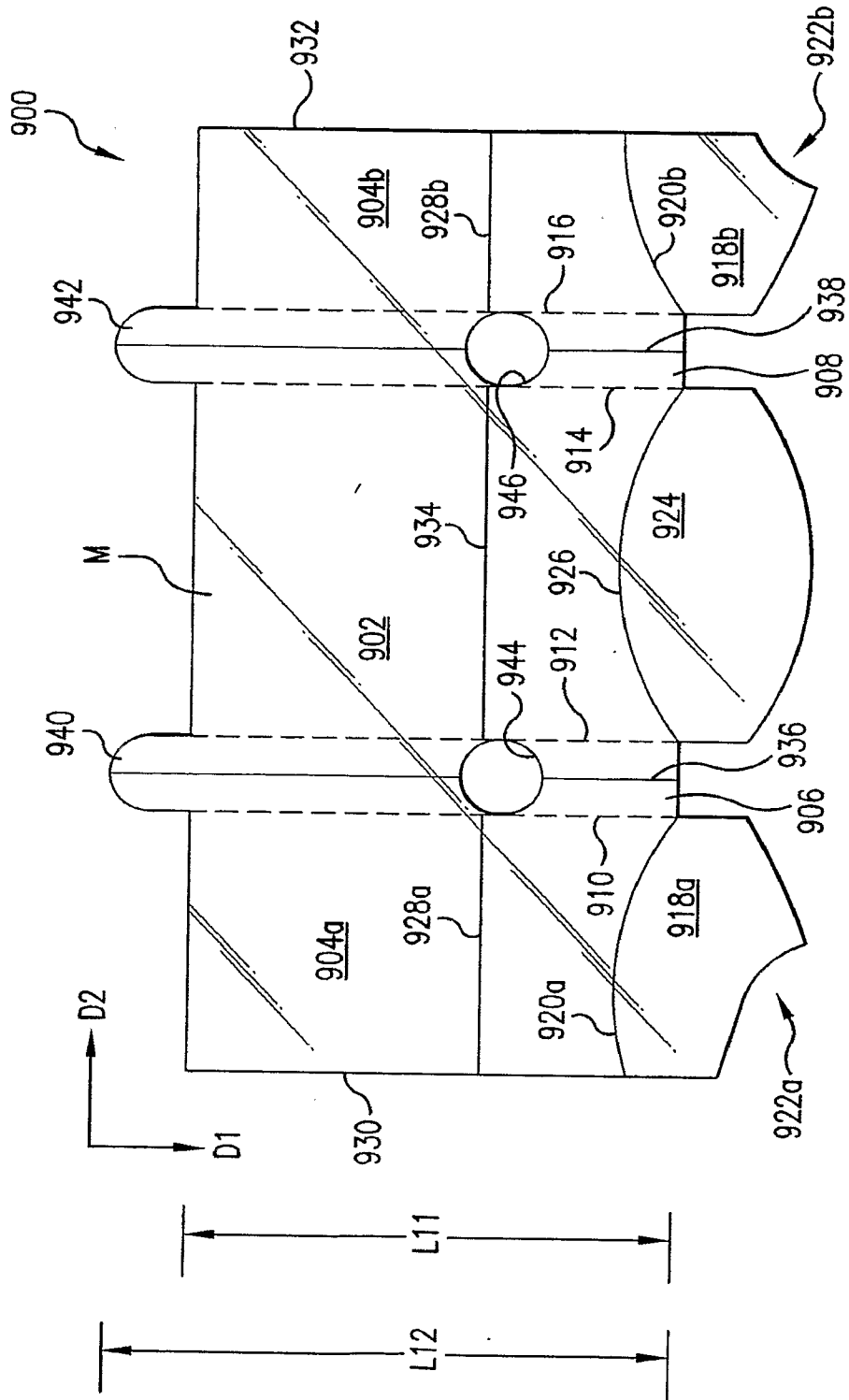

FIG.9A

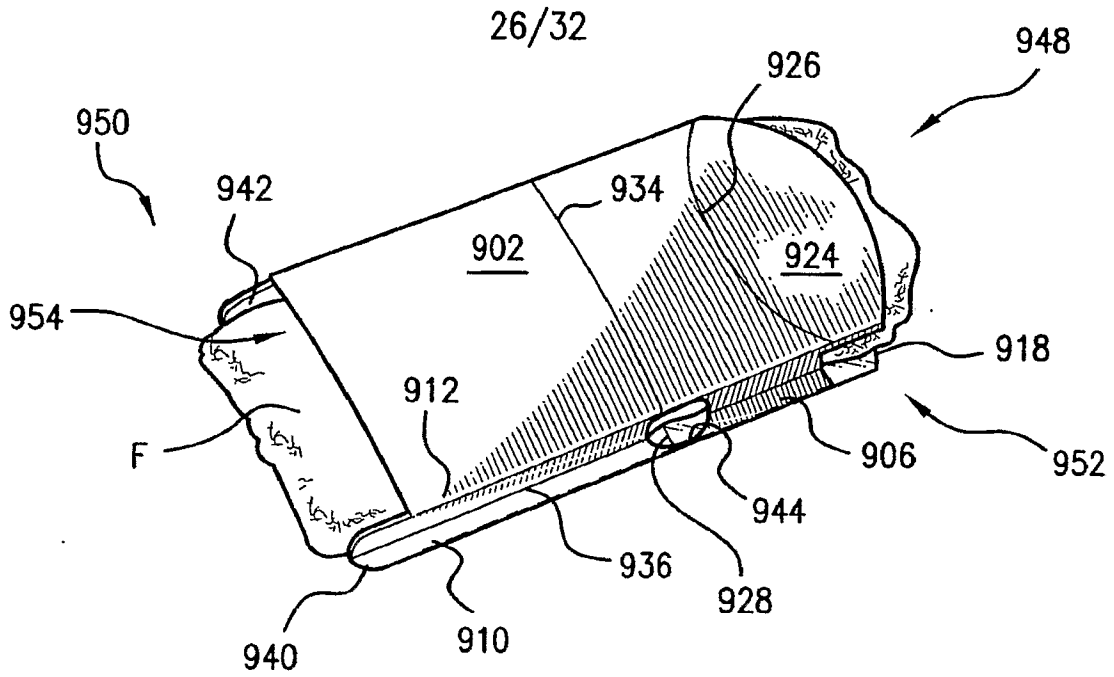

FIG. 9B

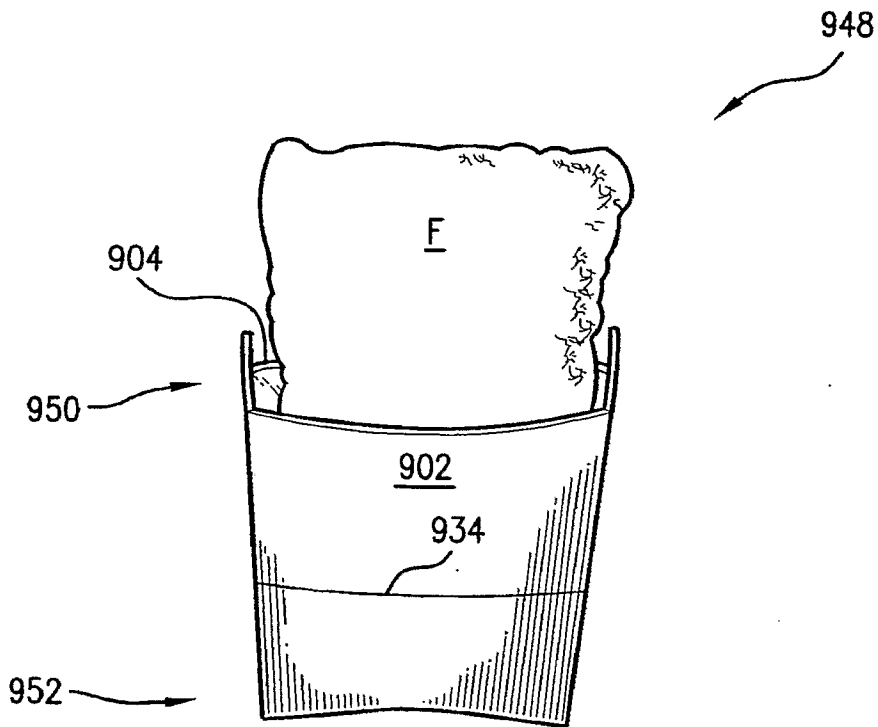
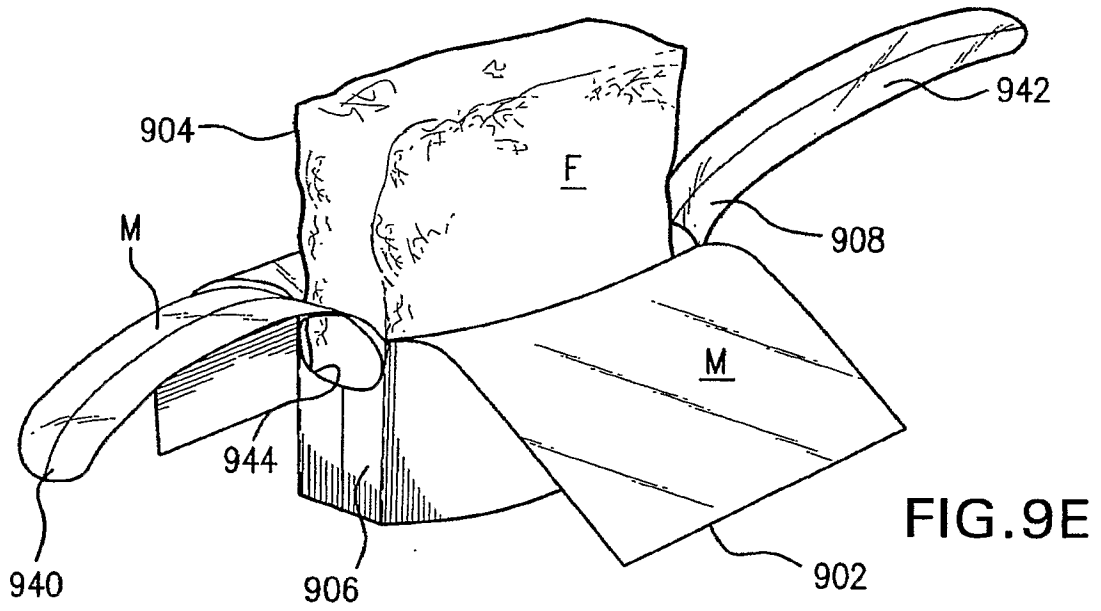
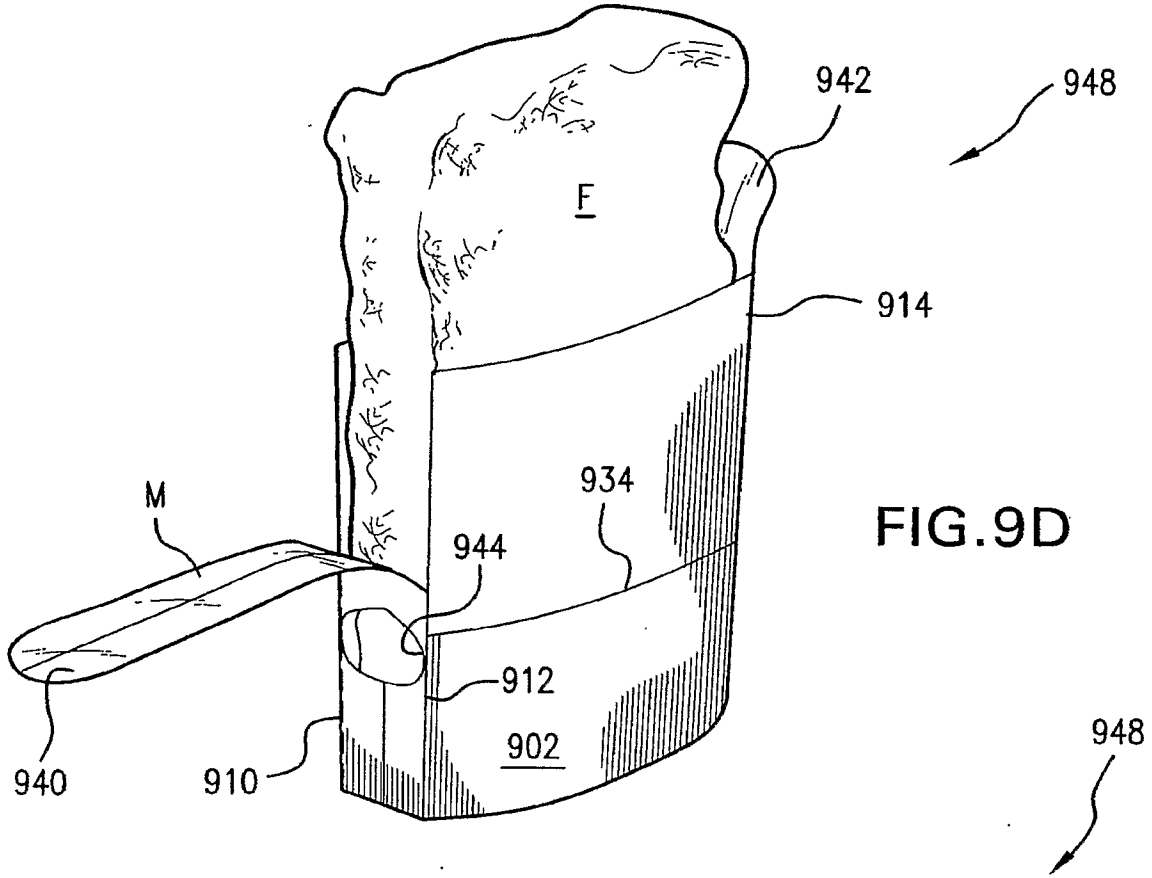

FIG. 9C

27/32



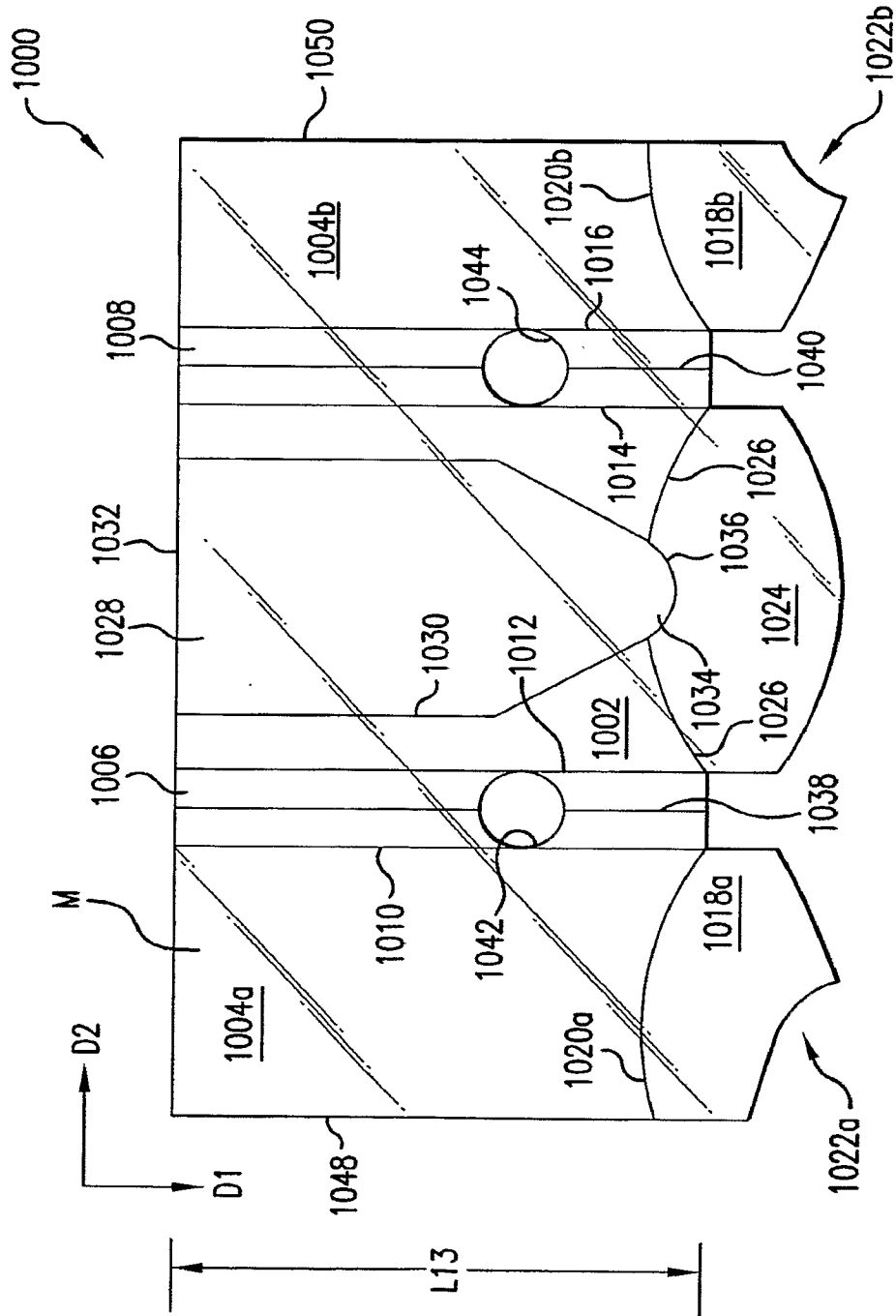

FIG. 10A

29/32

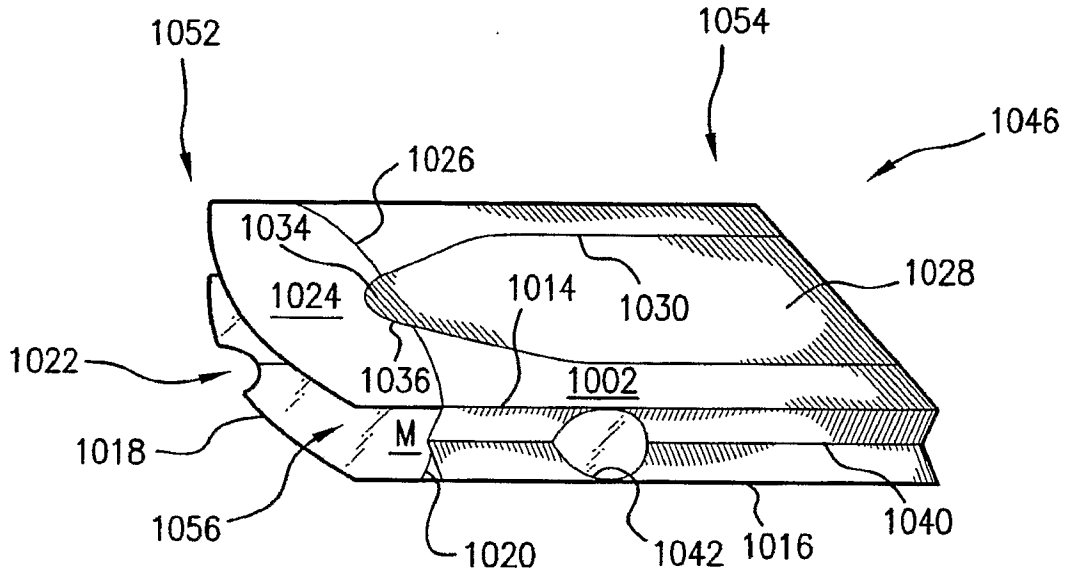

FIG. 10B

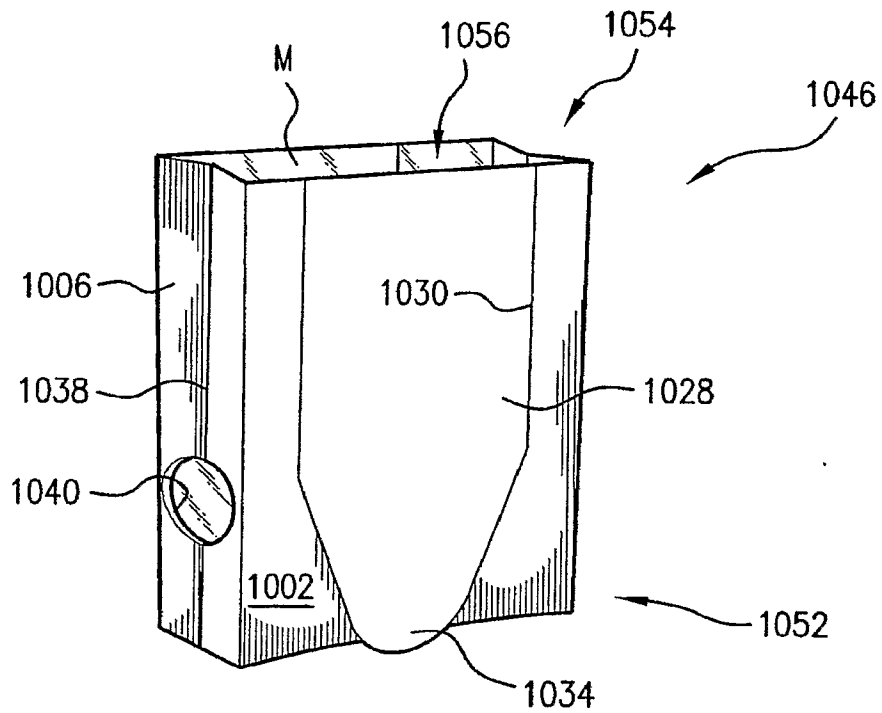

FIG. 10C

30/32

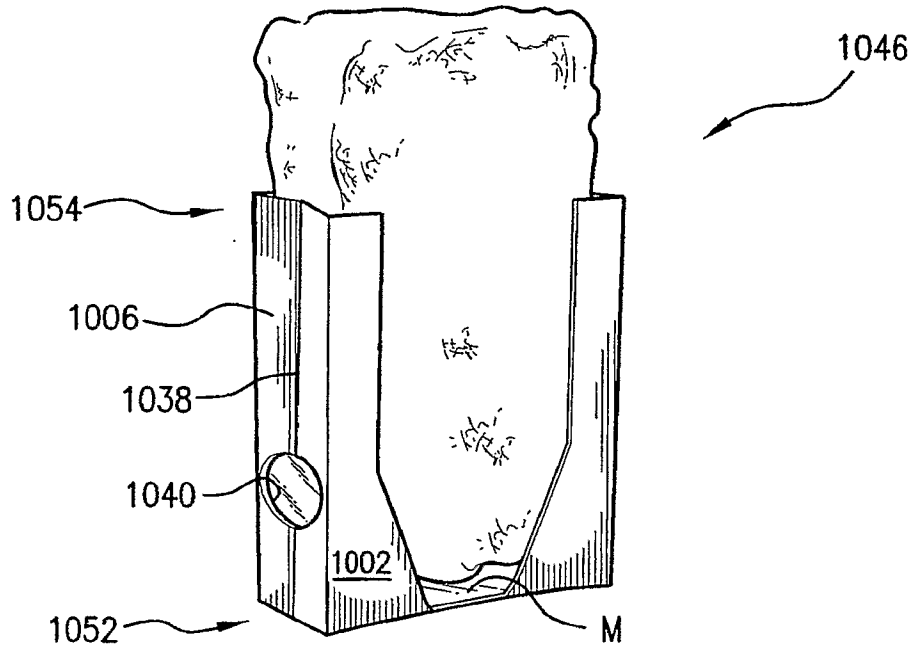

FIG. 10D

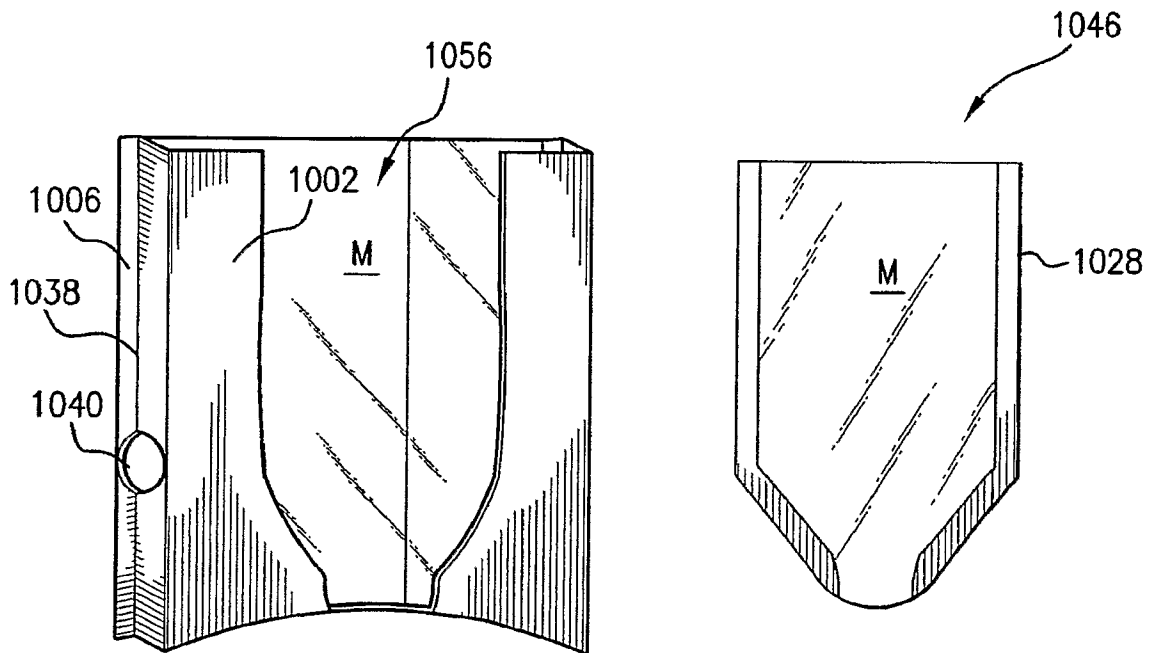

FIG. 10E

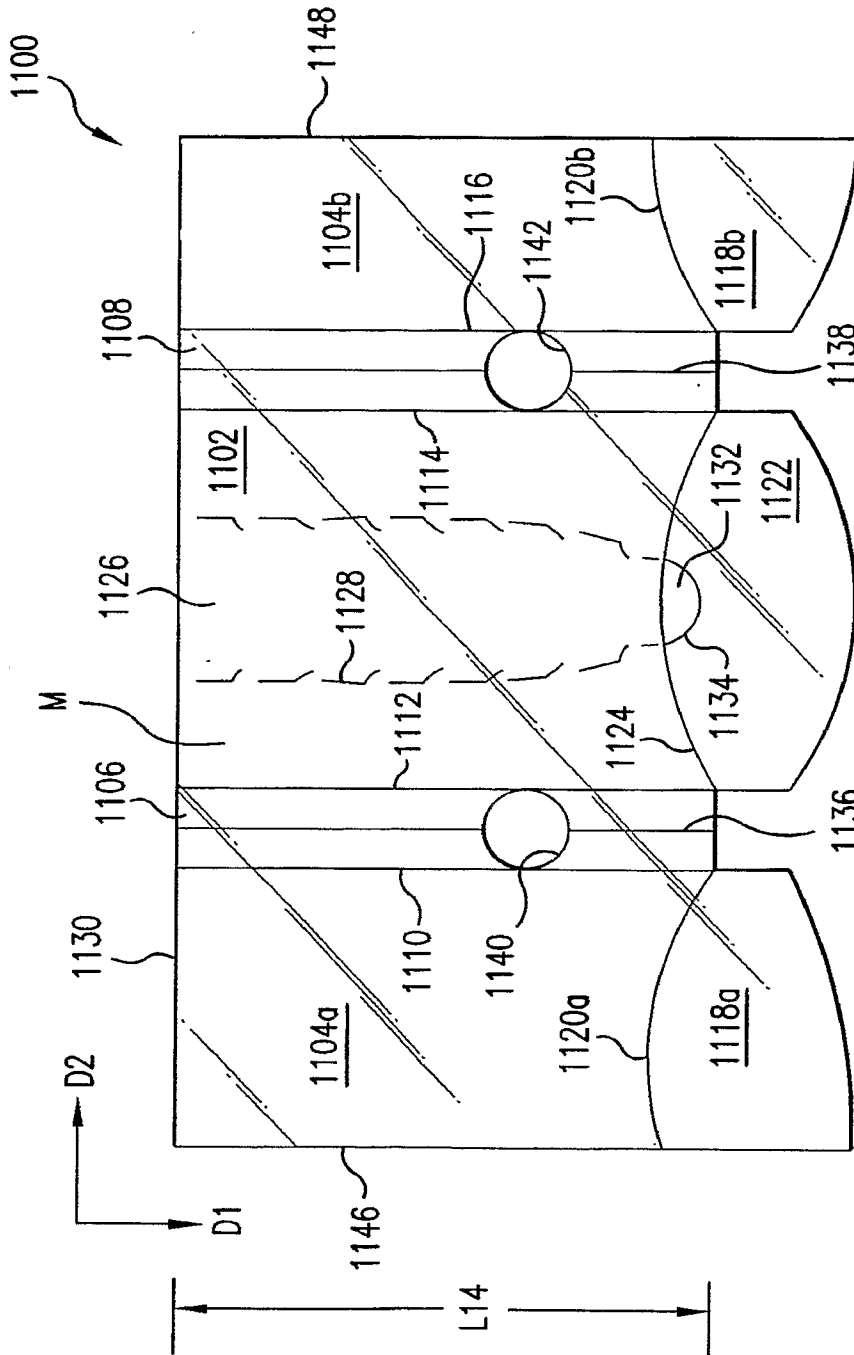

FIG.11A

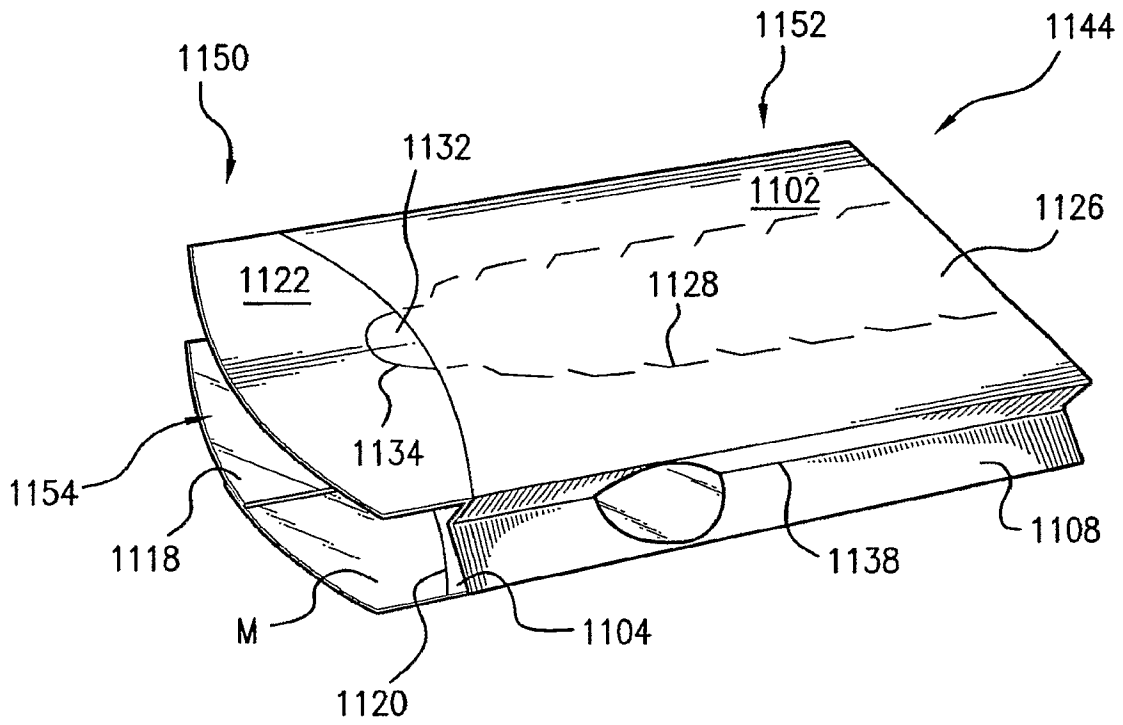

FIG. 11B