

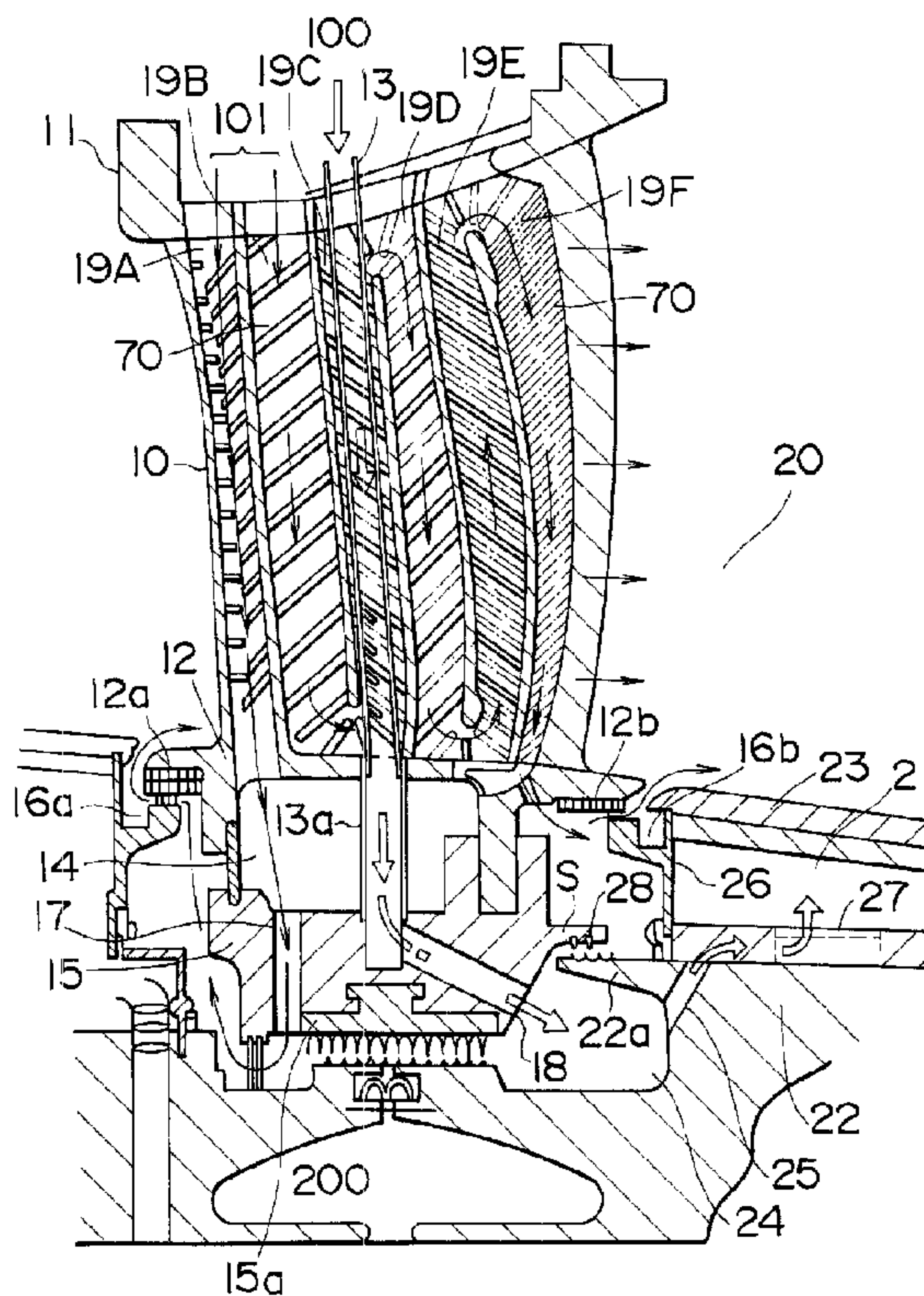

(22) Date de dépôt/Filing Date: 1998/03/10  
 (41) Mise à la disp. pub./Open to Public Insp.: 1998/09/11  
 (45) Date de délivrance/Issue Date: 2001/08/21  
 (30) Priorité/Priority: 1997/03/11 (056268/1997) JP

(51) Cl.Int.<sup>6</sup>/Int.Cl.<sup>6</sup> F01D 5/18, F01D 25/12  
 (72) Inventeurs/Inventors:  
 SUENAGA, Kiyoshi, JP;  
 HASHIMOTO, Yukihiro, JP;  
 FUKUNO, Hiroki, JP;  
 TOMITA, Yasuoki, JP  
 (73) Propriétaire/Owner:  
 MITSUBISHI HEAVY INDUSTRIES, LTD., JP  
 (74) Agent: FETHERSTONHAUGH & CO.

(54) Titre : ALIMENTATION EN AIR DE REFROIDISSEMENT DES AUBES D'UNE TURBINE A GAZ  
 (54) Title: BLADE COOLING AIR SUPPLYING SYSTEM OF GAS TURBINE



(57) Abrégé/Abstract:

In the present invention, an air pipe extends through a stationary blade between outer and inner shrouds. Further, an air passage is directed to a lower portion of the stationary blade and is communicated with the air pipe so that a serpentine cooling passage is formed. The air enters a cavity from the air passage and is discharged to a gas passage through an air hole, a passage and a seal. Thus, the cavity is sealed at a high pressure. Cooling air is supplied from the air passage to a rotating blade through a cooling air hole, a cooling air chamber, a radial hole and a lower portion of a platform. The stationary blade is cooled by the air through the air passage. The cooling air can be supplied to the rotating blade at a low temperature and a high pressure as they are. Accordingly, the air can be also supplied to the rotating blade when a rotor is cooled by vapor.

ABSTRACT

In the present invention, an air pipe extends through a stationary blade between outer and inner shrouds. Further, an air passage is directed to a lower portion of the stationary blade and is communicated with the air pipe so that a serpentine cooling passage is formed. The air enters a cavity from the air passage and is discharged to a gas passage through an air hole, a passage and a seal. Thus, the cavity is sealed at a high pressure. Cooling air is supplied from the air passage to a rotating blade through a cooling air hole, a cooling air chamber, a radial hole and a lower portion of a platform. The stationary blade is cooled by the air through the air passage. The cooling air can be supplied to the rotating blade at a low temperature and a high pressure as they are. Accordingly, the air can be also supplied to the rotating blade when a rotor is cooled by vapor.

TITLE OF THE INVENTION

BLADE COOLING AIR SUPPLYING SYSTEM OF GAS TURBINE

FIELD OF THE INVENTION AND RELATED ART STATEMENT

5           The present invention relates to a blade cooling air supplying system for effectively cooling a blade of a gas turbine by the air, and particularly to a system which makes it a possible to cool rotating blade (moving blade) by the air when a rotor is cooled by vapor.

10           Fig. 4 is a cross-sectional view of the interior of a conventional general gas turbine showing a flow of cooling air to a rotating blade. In Fig. 4, reference numerals 50, 51 and 52 respectively designate a stationary blade, an outer shroud and an inner shroud. Reference numeral 60 designates  
15 a rotating blade constructed such that this rotating blade 60 is attached to a rotor disk blade root portion 62 of a turbine disk 61 and is rotated between stationary blades 50.

          In the gas turbine constructed by the stationary blade 50 and the rotating blade 60 mentioned above, the rotating  
20 blade 60 is cooled by the air and is adapted to be cooled by using one portion of the rotor cooling air. Namely, a radial hole 65 is formed in the rotor disk blade root portion 62 and the rotor cooling air 100 is guided to each disk cavity 64. The rotor cooling air 100 is guided through the radial hole  
25 65 to a lower portion of a platform 63, and is supplied to

the rotating blade 60.

Fig. 3 is a detailed view of the stationary and rotating blades in the gas turbine of the above construction. In Fig. 3, the stationary blade 50 has the outer shroud 51 and the inner shroud 52. An air pipe 53 axially extends through the interior of the stationary blade 50. Namely, in this stationary blade 50, air 110 for seal is guided from a side of the outer shroud 51 to a cavity 54 and flows out to a passage 56 through a hole 57. A pressure within the passage 56 is increased in comparison with that in a combustion gas passage and one portion of this pressure flows into the combustion gas passage so as to prevent the invasion of a high temperature gas. Reference numeral 55 designates a labyrinth seal similarly used to seal the high temperature gas.

As mentioned above, the cooling air supplied to the rotating blade 60 guides the rotor cooling air 100 into the disk cavity 64 and also guides the rotor cooling air 100 to a shank portion 61 surrounded by a seal plate 66 in a lower portion of the platform 63 through the radial hole 65 extending through the interior of the rotor disk blade root portion 62. The rotor cooling air 100 is then supplied from this shank portion 61 to a passage for cooling the rotating blade 60. The air from a compressor may be also cooled through a cooler instead of usage of one portion of the rotor

cooling air and may be guided to the disk cavity 64.

As mentioned above, the blades of the conventional gas turbine are cooled by the air and the rotating blade 60 is particularly cooled by guiding one portion of the rotor cooling air. In recent years, a cooling system using vapor instead of the air has been researched. When a rotor system is cooled by the vapor, no air for cooling can be obtained from the rotor so that no rotating blade can be cooled by the air in the conventional structure.

With respect to the stationary blade 50, as explained with reference to Fig. 3, the air 110 for seal is blown out to the cavity 54 of the stationary blade 50 from the air pipe 53 extending through the interior of the stationary blade. Thus, the interior of the cavity 54 is held at a high pressure and the pressure of the passage 56 is set to be higher than the pressure of the combustion gas passage so that the invasion of a high temperature gas into the interior of the stationary blade is prevented. Namely, the air 110 for seal blown out to the cavity 54 partially flows out to the high temperature combustion gas passage through the hole 57 and the passage 56. When an amount of this flowing-out air is increased, efficiency of the gas turbine is reduced.

#### OBJECT AND SUMMARY OF THE INVENTION

Therefore, a first object of the present invention is

to provide a blade cooling air supplying system of a gas turbine in which the air for cooling a rotating blade is supplied from a stationary blade to the rotating blade instead of using one portion of the air for cooling a rotor, and the rotating blade can be also cooled by the air when a vapor cooling system is adopted to cool the rotor.

A second object of the present invention is to provide a blade cooling air supplying system of a gas turbine having a structure for effectively supplying the air for sealing the stationary blade in addition to the above first object.

A third object of the present invention is the same as the first object with respect to the supply of the cooling air from the stationary blade to the rotating blade, but is to provide a blade cooling air supplying system of the gas turbine in which this cooling air from an air supplying system is utilized as the air for seal and can cool the rotating blade.

Therefore, the present invention provides the following (1), (2) and (3) means to respectively achieve the above-mentioned first, second and third objects.

(1) A blade cooling air supplying system of a gas turbine characterized in that the gas turbine has plural rotating blades each attached to a rotor through a blade root portion and also has plural stationary blades arranged alternately with the rotating blades such that each of the

21326-217

stationary blades has outer and inner shrouds, a cavity for seal in a lower portion of the inner shroud, and a seal box in a lower portion of the cavity for seal, and the blade cooling air supplying system comprises an air pipe extending through  
5 each of said stationary blades from the outer shroud to the inner shroud and inserted into the respective seal box, a rotating blade side cooling air introducing portion arranged in the blade root portion of each of said rotating blades and guiding cooling air to each of said rotating blades, and a  
10 cooling air passage arranged in said seal box and communicated with said air pipe and opened toward an inlet of said rotating blade side cooling air introducing portion, and the cooling air is sent to said air pipe and is blown out from said cooling air passage to the inlet of said rotating blade side cooling air  
15 introducing portion and is sent from the rotating blade side cooling air introducing portion to each of said rotating blades.

(2) In the above (1), the entirety of the air supplied to said air pipe out of the cooling air supplied from  
20 an outer shroud side of each stationary blade is supplied to each of said rotating blades, and the cooling air supplied to a leading edge portion passage among the air for cooling each stationary blade is sent as the air for seal to the cavity of each of said stationary blades.

(3) A blade cooling air supplying system of a gas  
25 turbine characterized in that the gas turbine has plural rotating blades each attached to a rotor through a blade root portion and also has plural stationary blades arranged alternately with the rotating blades such that each of the  
30 stationary blades has outer and inner shrouds, a cavity for seal in a lower portion of the inside shroud, and a seal box in

21326-217

a lower portion of the cavity for seal, and the blade cooling air supplying system comprises an air passage extending through each of said stationary blades from the outer shroud to the inner shroud and communicated with the respective cavity, a  
5 rotating blade side cooling air passage arranged in the blade root portion of each of said rotating blades and guiding cooling air to each of said rotating blades, and a seal box side cooling air passage arranged in said seal box and connecting said cavity to said rotating blade side cooling air  
10 passage, and said cavity is set to have a pressure higher than that of a combustion gas passage by sending the cooling air to the air passage of each of said stationary blades, and the cooling air is sent to each of said rotating blades through said rotating blade side cooling air passage.

15 In the above (1) of the present invention, the cooling air is supplied from the air pipe of each stationary blade and is blown out to the inlet of the cooling air introducing portion on a rotating blade side from the cooling air passage

20

arranged in the seal box. The cooling air is then guided from the cooling air introducing portion to the rotating blade. However, this cooling air can be directly supplied from the stationary blade to the rotating blade at a high pressure and a low temperature as they are. Accordingly, similar to the conventional air cooling for cooling the rotating blade by one portion of the rotor cooling air, the rotating blade can be effectively cooled by the air. Such a blade cooling air supplying system can be used as an air cooling system for the blades in a gas turbine in which the rotor is cooled by vapor.

In the above (2) of the present invention, the entirety of the cooling air from the air pipe is used to cool the rotating blade. The air for sealing the stationary blade is separately transmitted through a leading edge portion of the stationary blade and cools this leading edge portion. Thereafter, this air is used to pressurize the cavity. Accordingly, in addition to the effects of the above (1) of the present invention, the cooling air is effectively utilized.

Further, in the above (3) of the present invention, the cooling air supplied from the air passage of the stationary blade first flows into the cavity and sets an internal pressure of the cavity to be higher than that of the combustion gas passage. Thereafter, the cooling air is

guided to the rotating blade side cooling air passage and is supplied to the rotating blade. Accordingly, the cooling air is effectively utilized. As a result, an air amount escaping from a portion between the rotating and stationary blades to the combustion gas passage can be reduced. Similar to the above (1) and (2) of the present invention, the a cooling air supplying system for the blades can air cool the blades in a gas turbine in which the rotor is cooled by vapor.

In the above (1) of the present invention, the gas turbine has plural rotating blades each attached to a rotor through a blade root portion and also has plural stationary blades arranged alternately with the rotating blades such that each of the stationary blades has outer and inner shrouds, a cavity for seal in a lower portion of the inner shroud, and a seal box in a lower portion of the cavity for seal, and the blade cooling air supplying system comprises an air pipe extending through each of said stationary blades from the outer shroud to the inner shroud and inserted into said seal box, a rotating blade side cooling air introducing portion arranged in the blade root portion of each of said rotating blades and guiding cooling air to each of said rotating blades, and a cooling air passage arranged in said seal box and communicated with said air pipe and opened toward an inlet of said rotating blade side cooling air introducing portion. Accordingly, the cooling air is blown

out to the inlet of the cooling air introducing portion on  
the rotating blade side from the cooling air passage and is  
then sent from the cooling air introducing portion on the  
rotating blade side to each rotating blade. This cooling air  
5 can be directly supplied from each stationary blade to the  
rotating blade at a high pressure and a low temperature as  
they are. Accordingly, cooling effects of the rotating blade  
can be improved.

Accordingly, the invention of this (1) can be used as  
10 an air cooling system for the blades in a gas turbine in  
which the rotor is cooled by vapor.

With respect to the above (2) of the present invention,  
in the invention of the above (1), the entirety of the  
cooling air supplied to said air pipe out of the cooling air  
15 supplied from an outer shroud side of each stationary blade  
is supplied to each of said rotating blades, and the cooling  
air supplied to a leading edge portion passage among the air  
for cooling each of said stationary blades is sent as the air  
for seal to the cavity of each of said stationary blades.  
20 Accordingly, the entirety of the cooling air from the air  
pipe is used to cool each rotating blade. The air for  
sealing each stationary blade is separately transmitted  
through a leading edge portion of the stationary blade and  
cools this leading edge portion. Thereafter, this air is  
25 used to pressurize the cavity. Accordingly, in addition to

the effects of the above (1) of the present invention, the cooling air is effectively utilized.

The above (3) of the present invention is a blade cooling air supplying system of a gas turbine having rotating and stationary blades similar to those of the above (1) and constructed such that the blade cooling air supplying system comprises an air passage extending through each of said stationary blades from the outside shroud to the inner shroud and communicated with said cavity, a rotating blade side cooling air passage arranged in the blade root portion of each of said rotating blades and guiding cooling air to each of said rotating blades, and a seal box side cooling air passage arranged in said seal box and connecting said cavity to said rotating blade side cooling air passage.

Accordingly, the cooling air first flows into the cavity and sets an internal pressure of the cavity to be higher than that of the combustion gas passage. Thereafter, the cooling air is guided to the rotating blade side cooling air passage and is supplied to each rotating blade. Accordingly, the cooling air is efficiently utilized. As a result, the amount of air escaping from a portion between the rotating and stationary blades to the combustion gas passage can be reduced.

Accordingly, similar to the above (1) and (2) of the present invention, the invention of the above (3) can be also

used as a system for air cooling the blades in a gas turbine in which the rotor is cooled by vapor.

#### BRIEF DESCRIPTION OF THE DRAWINGS

5 Fig. 1 is a cross-sectional view of root portions of stationary and rotating blades to which a blade cooling air supplying system in accordance with a first embodiment of the present invention is applied.

10 Fig. 2 is a cross-sectional view of root portions of stationary and rotating blades to which a blade cooling air supplying system in accordance with a second embodiment of the present invention is applied.

15 Fig. 3 is a cross-sectional view of a rotating blade in which a cooling air supplying system to the rotating blade of a conventional gas turbine is applied.

Fig. 4 is a cross-sectional view of a blade portion of the conventional gas turbine showing a flow of cooling air to the rotating blade.

#### 20 DETAILED DESCRIPTION OF THE PREFERRED EMBODIMENTS

The embodiment modes of the present invention will next be described in detail on the basis of the drawings. Fig. 1 is a cross-sectional view of a blade portion to which a blade cooling air supplying system of a gas turbine in accordance with a first embodiment of the present invention is applied.

25

In Fig. 1, reference numeral 10 designates a stationary blade having an outside shroud 11 and an inner shroud 12. Reference numeral 13 designates an air pipe extending through the interior of the stationary blade and the air 100 for cooling is guided by this air pipe 13. Reference numeral 14 designates a cavity arranged in a lower portion of the inner shroud 12. A tube 13a connected to the air pipe 13 hermetically passes through the interior of the cavity 14. Reference numeral 15 designates a seal box for supporting a labyrinth seal 15a. Reference numerals 16a and 16b designate passages formed by seal portions 12a, 12b of the inner shroud 12 in both end portions thereof. Reference numeral 17 designates an air hole extending through the seal box 15 and communicating the cavity 14 with the passage 16a. Reference numeral 18 designates a cooling air passage arranged in the seal box 15. The cooling air passage 18 communicates the tube 13a continuously connected to the air pipe 13 with a cooling air chamber 24 on a rotating blade side. An air passage 19A for seal guides the air 101 from the outer shroud 11. Air passages 19B, 19C, 19D, 19E and 19F form a serpentine cooling flow passage.

Reference numerals 20, 21 and 22 respectively designate an unillustrated rotating blade, a shank portion and a rotor disk blade root portion. This rotor disk blade root portion 22 has a projecting portion 22a. A seal portion 28 is formed

between this projecting portion 22a and the seal box 15 of the stationary blade 10. Reference numerals 23 and 24 respectively designate a platform and a cooling air chamber in the blade root portion 22. The cooling air chamber 24 is formed by the projecting portion 22a, the seal chamber 28, the seal box 15 of the stationary blade 10 and the labyrinth seal 15a. The cooling air chamber 24 is communicated with the cooling air passage 18 arranged in the seal box 15 on a stationary blade side.

Reference numeral 25 designates a radial hole formed in the rotor disk blade root portion 22. The radial hole 25 is communicated with the cooling air chamber 24 and an air reservoir 27 formed in the blade root portion 22 and the shank portion 21. Namely, an air introducing portion is constructed by the cooling air passage 24, the radial hole 25 and the air reservoir 27. Reference numeral 26 designates a seal plate in a lower portion of the platform 23. The passage 16b is formed by the seal plate 26 and the seal portion 12b on a stationary blade side. A turbulator 70 is arranged within the air passages 19A to 19F of the stationary blade 10 to provide turbulence to a cooling air flow and improve a heat transfer rate.

In the above first embodiment, the rotor is cooled by vapor and a vapor cavity 200 is arranged. The rotor is cooled by the vapor from the vapor cavity 200. The

stationary blade 10 and the rotating blade 20 are cooled by the air. One portion of the air 101 first flows into the interior of the stationary blade from the outside shroud 11 through the passage 19A on a leading edge side. This air  
5 cools the leading edge and is blown out to the cavity 14 and passes through the air hole 17 of the seal box 15 and also passes through the passage 16a at a pressure equal to or higher than a predetermined pressure. The air then passes through the seal portion 12a and partially flows out onto the  
10 side of a high temperature gas passage. Accordingly, a rotor side of the combustion gas passage is held at a pressure higher than the pressure of the combustion gas passage by this air 101 for seal so that the invasion of a high temperature gas onto the rotor side of the combustion gas  
15 passage is prevented.

The remaining portion of the air 101 enters the passage 19B and is moved upward in the passage 19C from a lower portion of the passage 19B. Serpentine cooling is performed while the remaining portion of the air 101 sequentially  
20 passes through the passages 19D, 19E and 19F and is partially discharged from a trailing edge side. After this cooling, the air at a high temperature passes through the passage 16b and flows out to a gas flow passage on the trailing edge side from the seal portion 12b.

25 In contrast to this, the cooling air 100 flows into the

air pipe 13 from the outside shroud 11 and passes through the tube 13a continuously connected to a lower portion of the air pipe 13. The cooling air 100 further enters the cooling air chamber 24 through the cooling air passage 18 and stays as cooling air at a high pressure and a low temperature. The cooling air entering the cooling air chamber 24 further enters the air reservoir 27 through the radial hole 25 on the rotating blade side, and is guided from the platform 23 to an air passage for cooling arranged in an unillustrated rotating blade 20, and cools the rotating blade 20.

In the above-mentioned first embodiment, the air for cooling the rotating blade is supplied from only the air pipe 13 arranged in the stationary blade 10 and the tube 13a. The air pipe 13 and the tube 13a constitute an independent route. Accordingly, the air for cooling the rotating blade is directly supplied to the rotating blade 20 while the high pressure and the low temperature of the air are maintained. Therefore, the rotating blade 20 can be effectively cooled.

The air 101 for seal within the cavity 14 is independently supplied from the passage 19A at a leading edge. The air 101 passing through this passage 19A cools a leading edge portion and is then used as a seal. Accordingly, the air 101 can be used for both seal and cooling so that the air can be effectively utilized.

In the blade cooling air supplying system in the first

embodiment having such features, the air can be also supplied to the blades, especially the rotating blade 20 in the case of a gas turbine for cooling the rotor by vapor. Accordingly, the blades can be cooled by the air.

5            Fig. 2 is a cross-sectional view of a blade portion to which a blade cooling air supplying system in accordance with a second embodiment of the present invention is applied. In Fig. 2, this second embodiment is characterized in that one portion of the air supplied from a stationary blade to cool a  
10 rotating blade can be also utilized as the air for sealing the stationary blade, and the air escaping from a portion between the rotating and stationary blades to a combustion gas passage is reduced by effectively utilizing the air. These features will next be explained.

15            In Fig. 2, a stationary blade 30 has an outer shroud 31 and an inner shroud 32. Reference numeral 33 designates an air passage within the stationary blade. This air passage 33 may be formed within the stationary blade and may be also formed by arranging a tube. Reference numerals 34 and 35  
20 respectively designate a cavity and a seal box. The seal box 35 supports a labyrinth seal 35a for sealing a portion between the seal box 35 and a rotating blade 40. Reference numerals 36 and 37 respectively designate a passage and an air passage. The air passage 37 is formed in the seal box 35  
25 and communicates the cavity 34 with the passage 36.

Reference numerals 38a and 38b designate seals between an end portion of the inside shroud 32 of the stationary blade 30 and an end portion of a platform 43 of the rotating blade 40 described later. Reference numeral 39 designates an air  
5 reservoir formed between the labyrinth seal 35a and a baffle plate 47. The baffle plate 47 is arranged between the labyrinth seal 35a and a rotor disk blade root portion 42 of the rotating blade 40.

Reference numerals 40, 41 and 42 respectively designate  
10 a rotating blade and a shank portion formed in a lower portion of the platform 43, and a rotor disk blade root portion. Reference numerals 44 and 45 respectively designate cooling air passages. The cooling air passage 44 is formed  
15 such that this cooling air passage 44 extends through a rotor disk. The cooling air passage 44 is communicated with the air reservoir 39 and the cooling air passage 45 of the rotor disk blade root portion 42. Air passage portions of the rotor disk blade root portion 42 and the shank portion 41 are  
20 sealed by a seal plate 46 and the supplied cooling air does not escape to a combustion gas passage, but is reliably supplied to the rotating blade 40. In Fig. 2, reference numerals S and SF respectively designate a seal and a seal  
fin.

In the second embodiment of the above construction, the  
25 cooling air 100 from a compartment side flows into the cavity

34 from the interior of the stationary blade through the air passage 33. The cooling air 100 then passes through the air passage 37 and enters the air reservoir 39 through the labyrinth seal 35a at a pressure equal to or higher than a predetermined pressure. One portion of the air flowing out through the air passage 37 passes through the passage 36. When this air has a pressure equal to or higher than that of a combustion gas at a high pressure, the air passes through a seal 38a and flows out to the combustion gas passage. Thus, the interior of the cavity 34 is held at a pressure higher than that of the combustion gas passage so that the invasion of a high pressure combustion gas onto a rotor side of the combustion gas passage is prevented.

The cooling air of the air reservoir 39 passes through the cooling air passages 44 and 45 and enters the shank portion 41 via an unillustrated passage formed in the rotor disk blade root portion 42. The cooling air is then supplied to a passage for cooling the rotating blade 40 and cools the rotating blade 40. After this cooling, the air is discharged to the combustion gas passage. Both sides of the shank portion 41 and the blade root portion 42 formed in a lower portion of the platform 43 are sealed by the seal plate 46 so that the cooling air can be reliably supplied to the rotating blade 40 without escaping this cooling air to the combustion gas passage.

In the second embodiment explained above, the cooling air 100 supplied from the air passage 33 of the stationary blade 30 is reliably supplied to the rotating blade 40 without escaping this cooling air to the combustion gas passage, and can cool the rotating blade 40. Further, one portion of the cooling air of the air passage 33 is supplied to the cavity 34 as the air for seal. Accordingly, the air for seal is sent to the cavity 34 by forming a dedicated passage for seal, and an air amount escaping to the combustion gas passage can be reduced in comparison with a system for almost escaping the air to the combustion gas passage.

Similar to the blade cooling air supplying system in the first embodiment, the cooling air can be also supplied to the rotating blade 40 in such a blade cooling air supplying system in the second embodiment even in the case of a gas turbine for cooling the rotor by vapor. Accordingly, the rotating blade can be cooled by the air.

21326-217

CLAIMS:

1. A blade cooling air supplying system of a gas turbine which comprises:

5 a plurality of rotating blades each attached to a rotor through a blade root portion, and plural stationary blades arranged alternately with the rotating blades such that each stationary blade has outer and inner shrouds, a cavity for seal in a lower portion of the inner shroud, and a seal box in a lower portion of the cavity for seal;

10 an air pipe extending through each of said stationary blades from the outer shroud to the inner shroud and inserted into the respective seal box;

15 a rotating blade side cooling air introducing portion arranged in the blade root portion of each rotating blade and guiding cooling air to each rotating blade; and

a cooling air passage arranged in said seal box and communicating with said air pipe and opening toward an inlet of said rotating blade side cooling air introducing portion;

20 wherein the cooling air is sent to said air pipe and is blown out from said cooling air passage to the inlet of said rotating blade side cooling air introducing portion and is sent from the rotating blade side cooling air introducing portion to each rotating blade.

25 2. The blade cooling air supplying system of the gas turbine as claimed in claim 1, wherein substantially an entirety of the air supplied to said air pipe among the cooling air supplied from an outer shroud side of each stationary blade is supplied to each rotating blade, and the cooling air

21326-217

supplied to a leading edge portion passage out of the air for cooling each stationary blades is sent as the air for seal to the cavity of each stationary blade.

3. A blade cooling air supplying system of a gas turbine  
5 comprising:

a plural rotating blades each attached to a rotor through a blade root portion, and plural stationary blades arranged alternately with the rotating blades such that each stationary blade has outer and inner shrouds, a cavity for seal  
10 in a lower portion of the inner shroud, and a seal box in a lower portion of the cavity for seal;

an air passage extending through each stationary blade from the outer shroud to the inner shroud and communicating with the respective cavity;

15 a rotating blade side cooling air passage arranged in the blade root portion of each of said rotating blades and guiding cooling air to each rotating blade; and

a seal box side cooling air passage arranged in said seal box and connecting said cavity to said rotating blade side  
20 cooling air passage;

wherein said cavity is set to have a pressure higher than an external pressure by sending the cooling air to the air passage of each stationary blade, and the cooling air is sent to each rotating blade through said rotating blade side cooling  
25 air passage.



FIG. 2

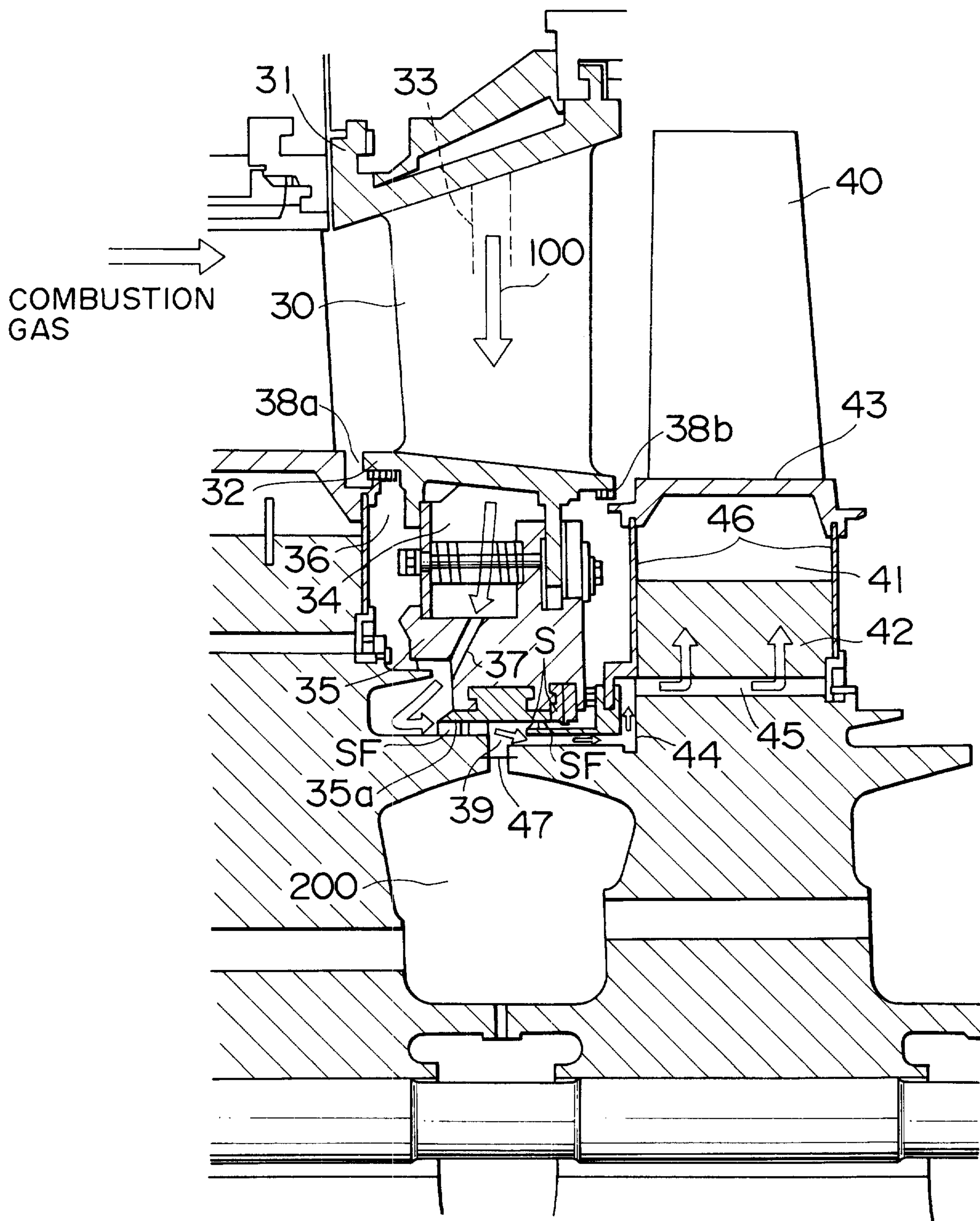

# FIG. 3 RELATED ART

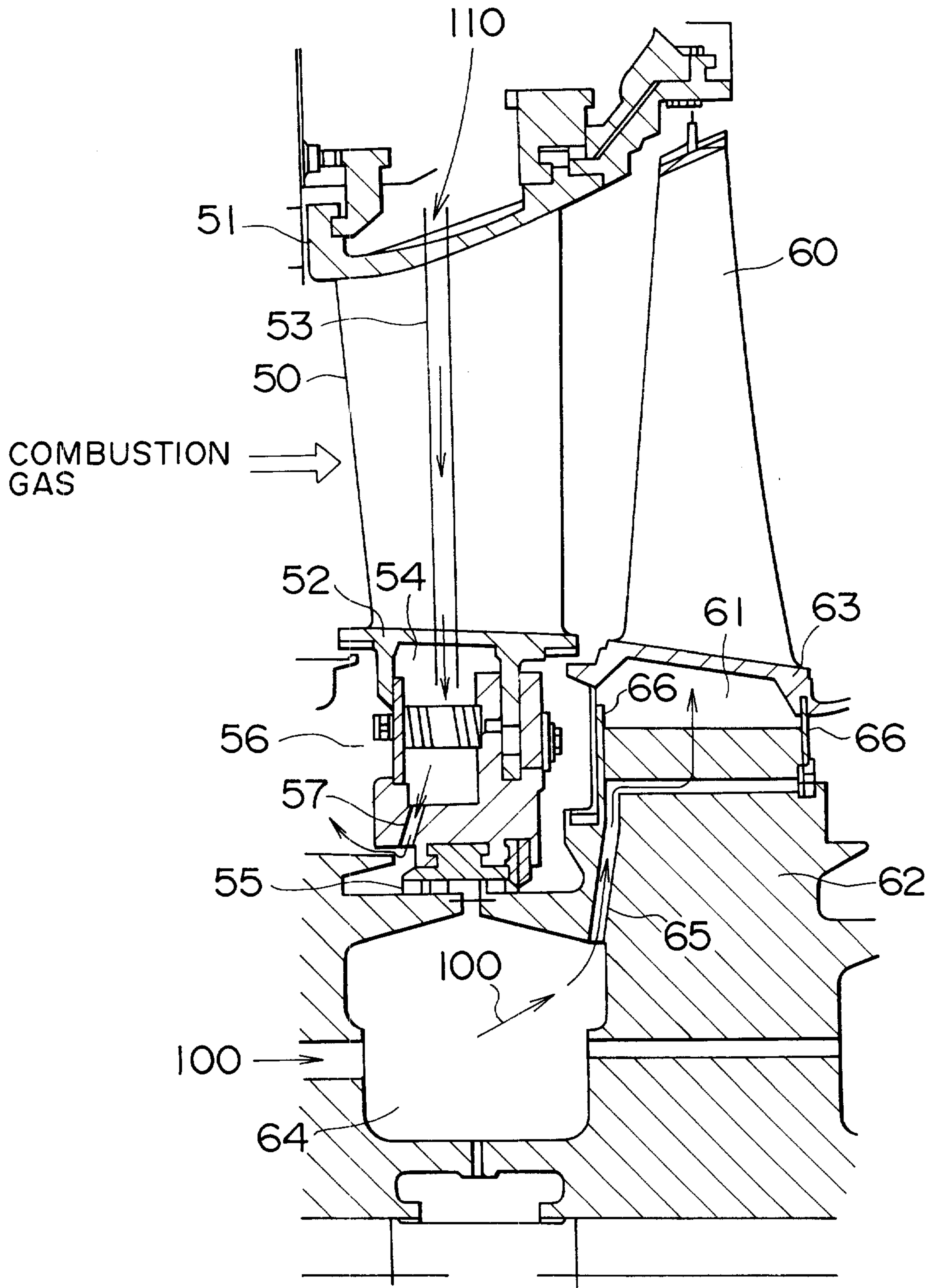
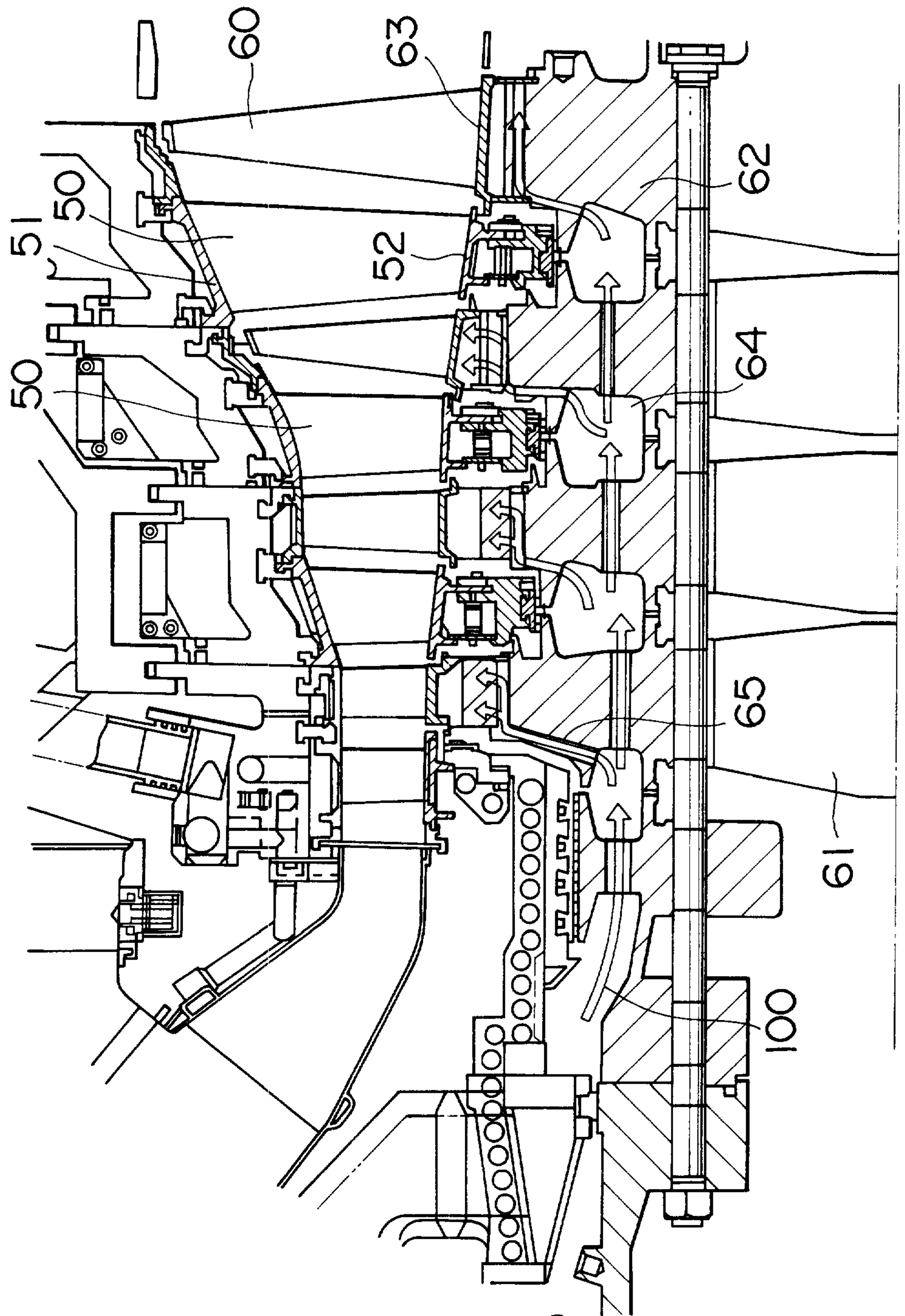

FIG. 4  
RELATED ART



Patent Agents  
Fetherstonhaugh & Co.

