

(12) UK Patent

(19) GB

(11) 2608562

(13) B

(45) Date of B Publication

16.04.2025

(54) Title of the Invention: **Draining member**

(51) INT CL: **E04B 1/64** (2006.01)

E04D 13/15 (2006.01)

E04D 13/158 (2006.01)

(21) Application No: **2214759.9**

(22) Date of Filing: **16.12.2020**

Date Lodged: **07.10.2022**

(86) International Application Data:
PCT/JP2020/046992 Ja 16.12.2020

(87) International Publication Data:
WO2022/130540 Ja 23.06.2022

(43) Date of Reproduction by UK Office **04.01.2023**

(72) Inventor(s):

**Mitsuharu Yachi
Masaki Watanabe
Toshiyuki Osada**

(73) Proprietor(s):

**Sekisui House, Ltd.
1-1-88, Oyodonaka, Kita-ku, Osaka-shi 531-0076,
Osaka, Japan**

(74) Agent and/or Address for Service:

**Appleyard Lees IP LLP
15 Clare Road, HALIFAX, West Yorkshire, HX1 2HY,
United Kingdom**

(56) Documents Cited:

**JP 2002276043 A
JP H0335765
JP S6336092**

(58) Field of Search:

As for published application 2608562 A viz:
INT CL **E04B, E04D**
Other: **Public JP utility model applns (examined
1922-1996),(unexamined 1971-2021); JP utility models
(regst specs 1996-2021),(public regst applns
1994-2021)**
updated as appropriate

Additional Fields

Other: **None**

GB
2608562
B

Fig.1

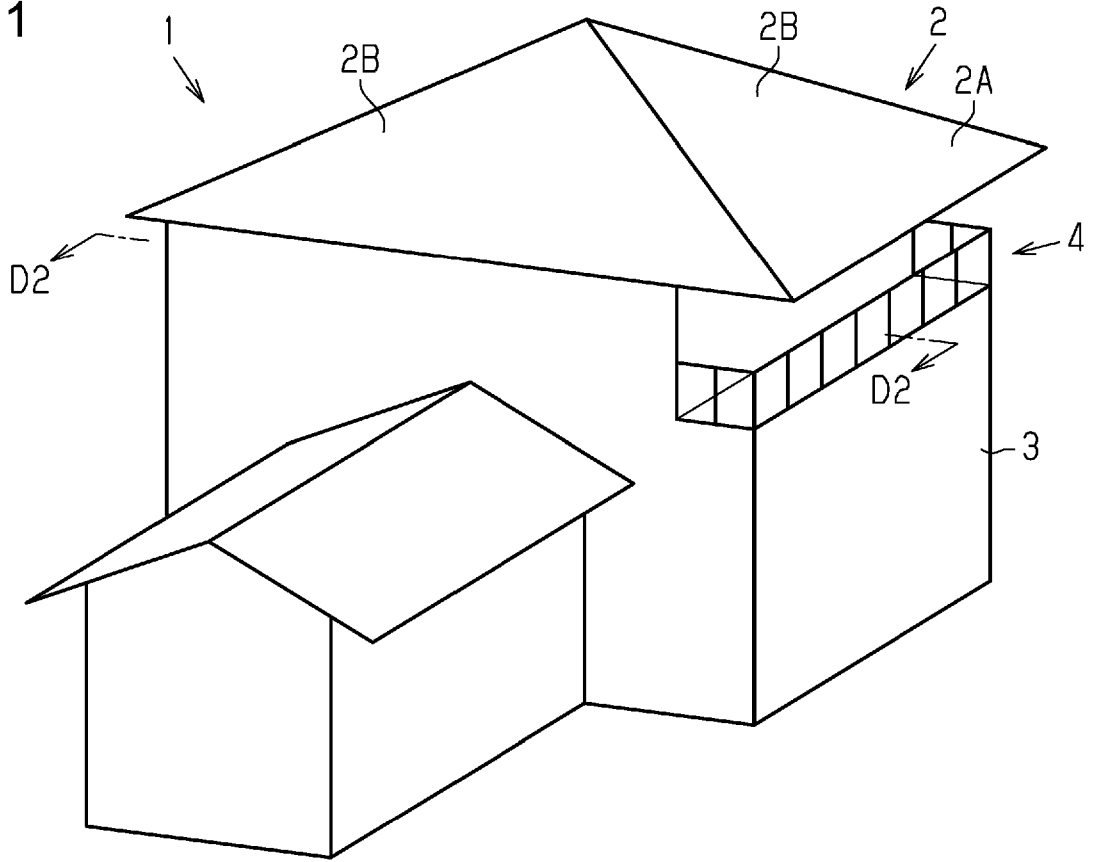

Fig.2

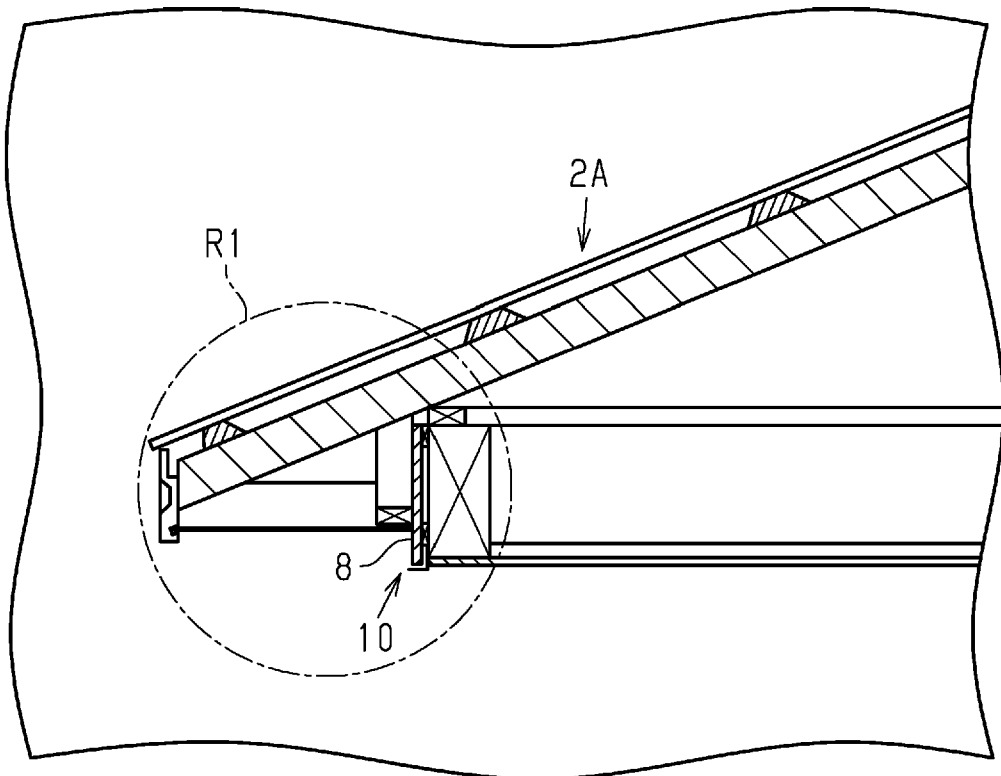

Fig.3

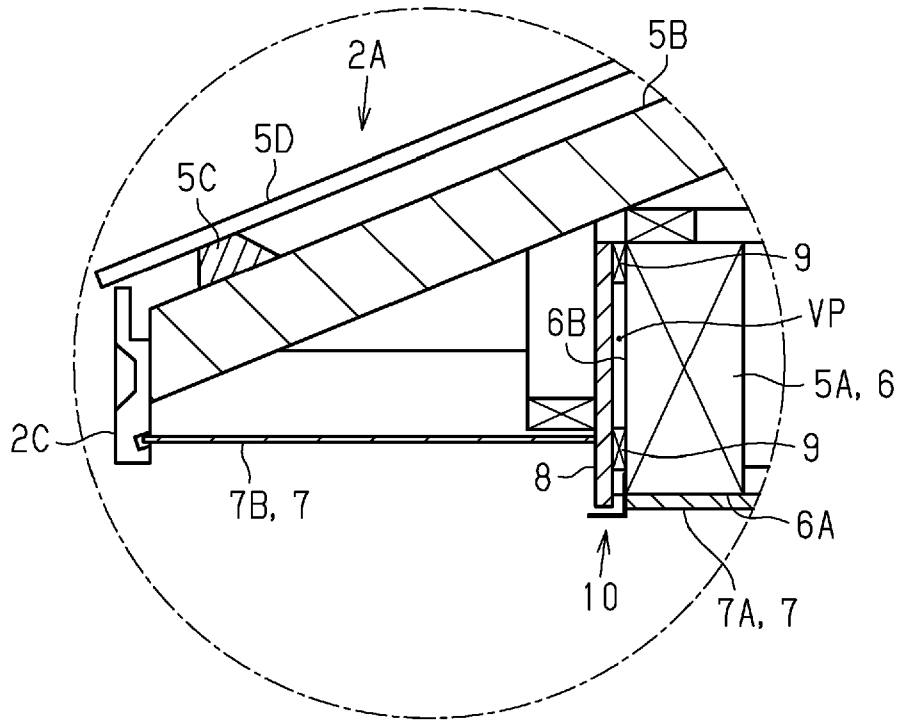

Fig.4

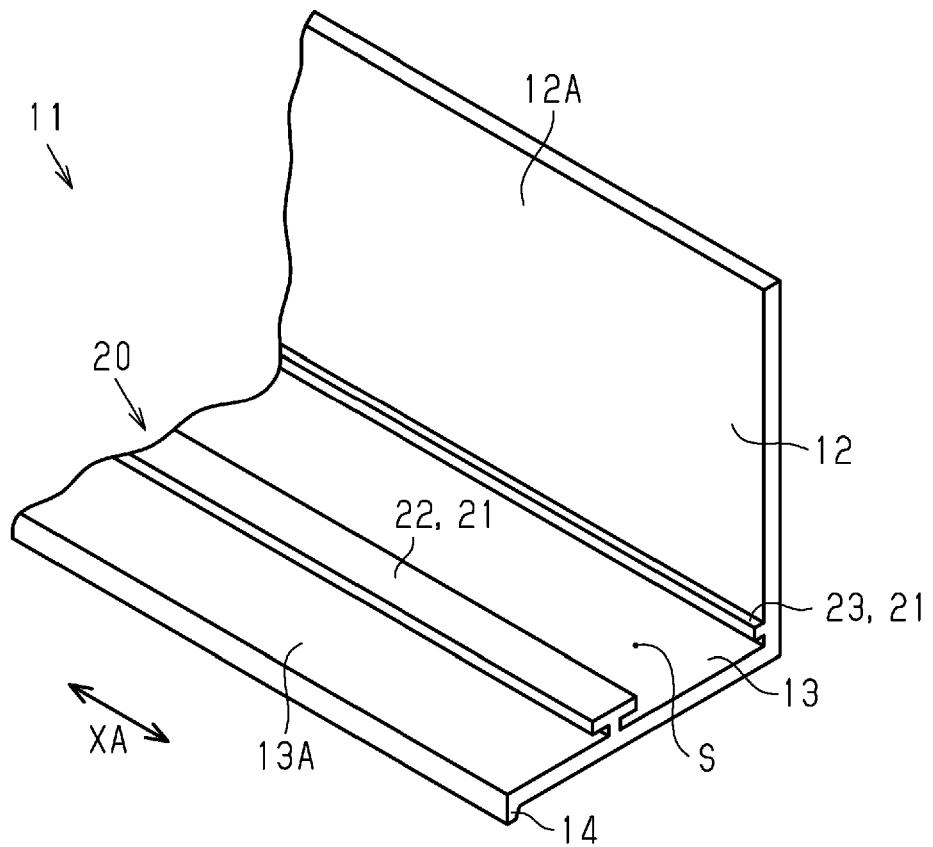

Fig.5

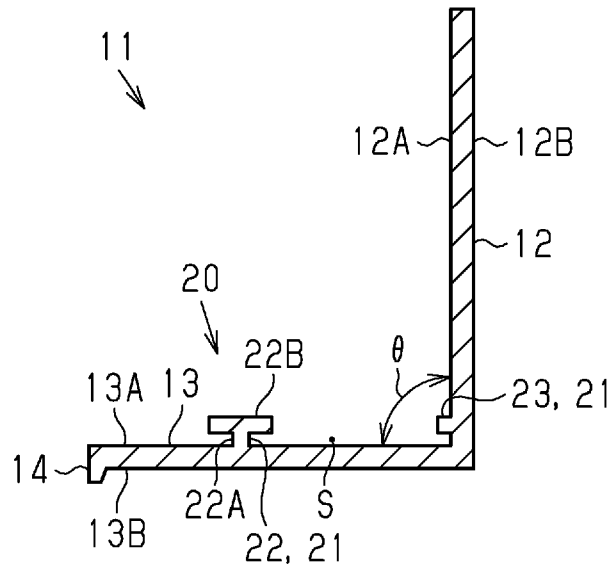

Fig.6

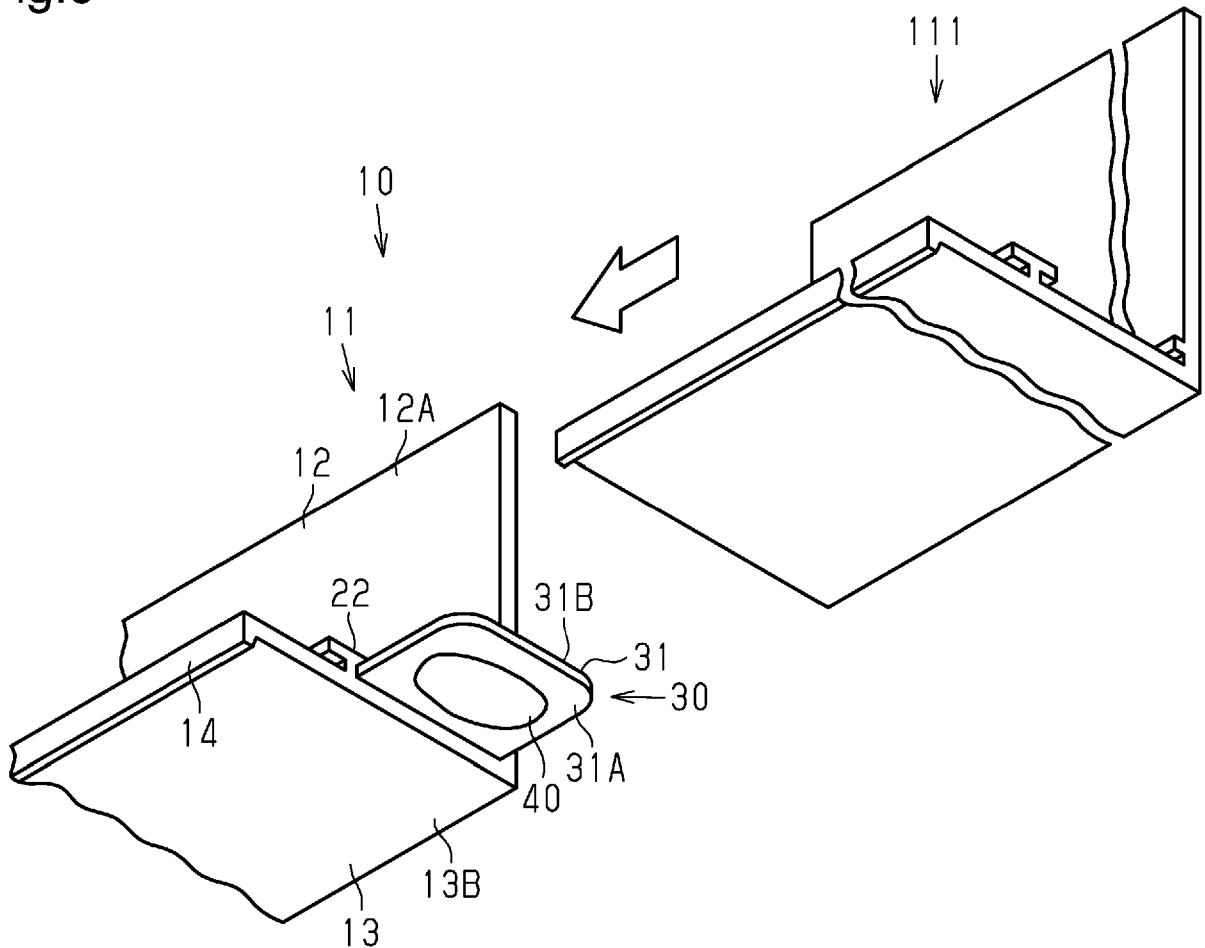

Fig.7

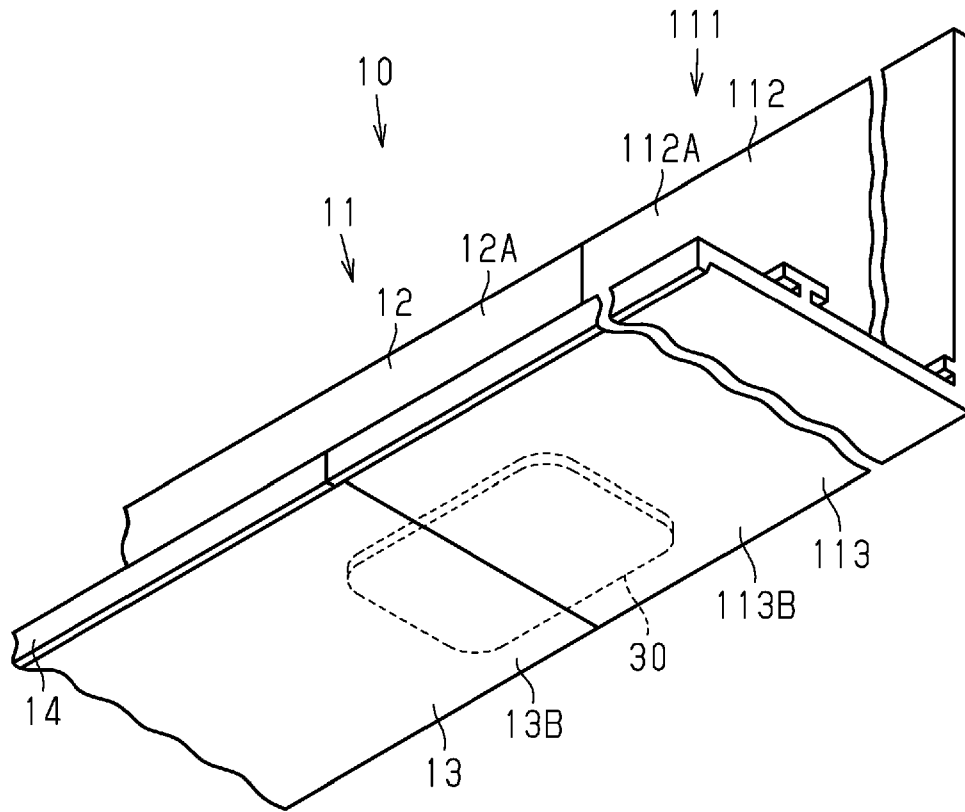

Fig.8

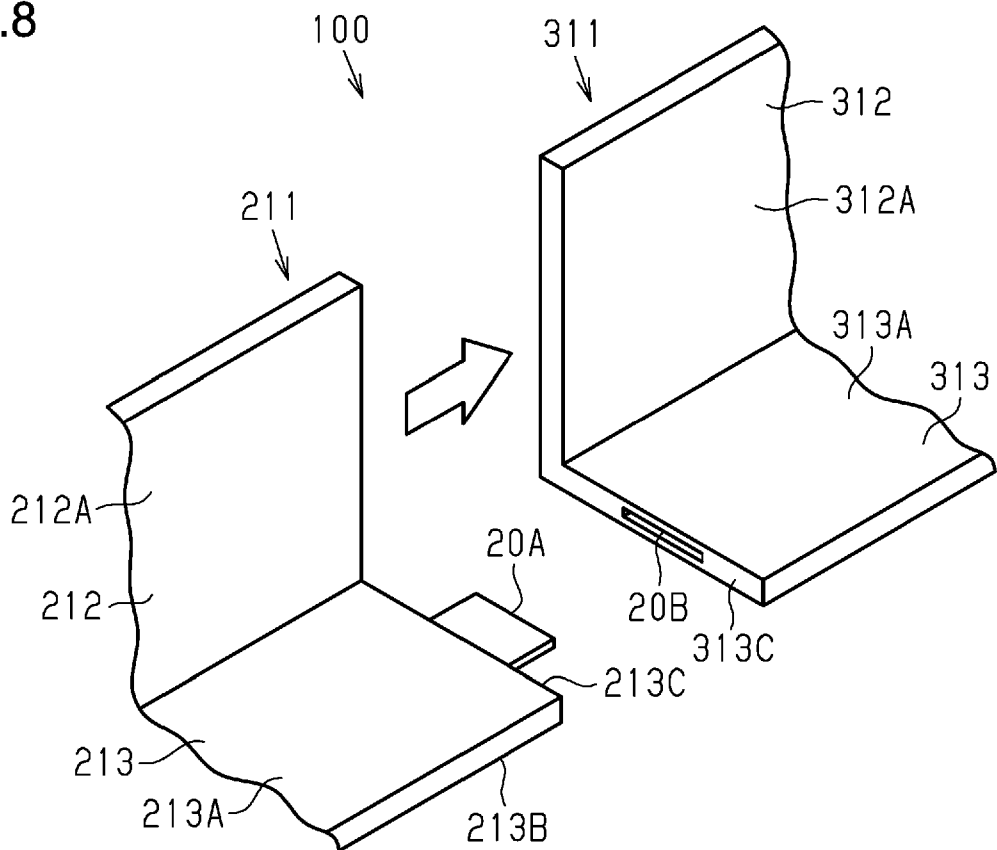
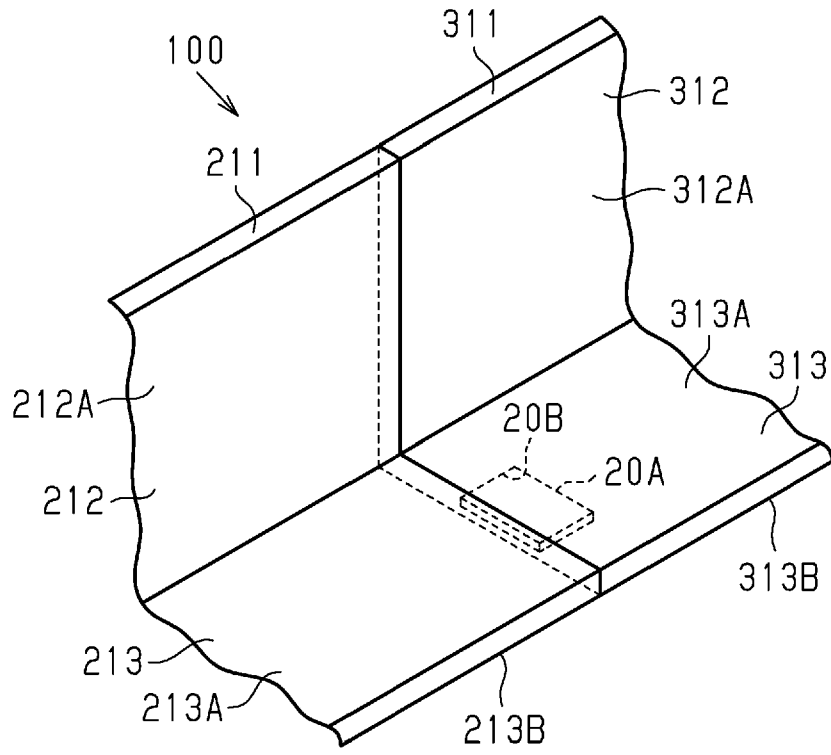

Fig.9



DESCRIPTION

TITLE OF INVENTION

DRAINING MEMBER

TECHNICAL FIELD

[0001] The present disclosure relates to a flashing member arranged on an exterior part of a building.

BACKGROUND ART

[0002] Techniques for arranging a flashing portion on the eaves of a building are known. Patent Literature 1 discloses an example of a configuration including a flashing portion. The flashing portion disclosed in the literature prevents water from entering a molding.

CITATION LIST

Patent Literature

[0003] Patent Literature 1: U.S. Patent No. 4339898

SUMMARY OF INVENTION

Technical Problem

[0004] The exterior part arranged on the outer surface of the building may include a flashing. For example, the flashing is arranged along the lower surface of the exterior part of a structure that projects from the outer wall of the building. Examples of the structure include a balcony, a veranda, a bay window, and the eaves edge of a roof. The flashing arranged on the exterior part of such a structure may include flashing members. The flashing members are arranged on the exterior part so as not to produce a gap between adjacent ones

of the flashing members. However, it is not easy to arrange the flashing members so as not to produce a gap between adjacent ones of the flashing member.

Solution to Problem

[0005] (1) The flashing member that solves the above-described problem is a flashing member arranged below an exterior part of a building. The flashing member includes a coupling portion that is coupled to an additional flashing member. The additional flashing member is separate from the flashing member.

The flashing member includes the coupling portion that couples the flashing member to the additional flashing member. This allows flashing members to be easily positioned when the flashing members are located below the exterior part.

[0006] (2) In the flashing member of (1), the coupling portion includes a retainer that retains a coupling member for coupling of the flashing member. The retainer of the flashing member and the retainer of the additional flashing member retain the coupling member so as to couple the flashing member to the additional flashing member.

The flashing member allows flashing members to be easily positioned when the flashing members are located below the exterior part.

[0007] (3) In the flashing member of (2), the coupling member is bonded to the coupling portion using an adhesive.

The flashing member increases a coupling force of the coupling member.

[0008] (4) In any one of the flashing members of (1) to (3), a predetermined surface of the flashing member is flush with a predetermined surface of the additional flashing member in a state where the flashing member is coupled to the additional flashing member.

The flashing member includes no gap between the flashing members and thus has an improved design.

[0009] (5) In the flashing member of (1), the flashing member includes a first flashing member and a second flashing member. The second flashing member being different separate from the first flashing member. The first flashing member includes at least a first coupling portion. The second flashing member includes at least a second coupling portion. The first coupling portion of the first flashing member is couplable to the second coupling portion of the second flashing member or the second coupling portion of the second flashing member is couplable to the first coupling portion of the first flashing member.

The flashing member allows flashing members to be easily positioned when the flashing members are located below the exterior part.

[0010] (6) In any one of the flashing members (1) to (5), the flashing member is made of aluminum.

In the flashing member, when the flashing is adjusted in length, the flashing member can be easily cut.

Advantageous Effects of Invention

[0011] The flashing member according to the present disclosure allows flashing members to be easily positioned when the flashing members are located below the exterior part.

BRIEF DESCRIPTION OF DRAWINGS

[0012] Fig. 1 is an outer view showing a building on which a flashing of a first embodiment is arranged.

Fig. 2 is a partial cross-sectional view taken along line D2-D2 in the building of Fig. 1.

Fig. 3 is an enlarged view showing region R1 of Fig. 2.

Fig. 4 is a perspective view showing the flashing member of the first embodiment.

Fig. 5 is a cross-sectional view showing the flashing member of Fig. 4.

Fig. 6 is a perspective view of the flashing, showing a state before the flashing member of the first embodiment is coupled.

Fig. 7 is a perspective view of the flashing, showing a state in which the flashing member of the first embodiment is coupled.

Fig. 8 is a perspective view of a flashing, showing a state before a flashing member of a second embodiment is coupled.

Fig. 9 is a perspective view of the flashing, showing a state in which the flashing member of the second embodiment is coupled.

DESCRIPTION OF EMBODIMENTS

[0013] First Embodiment

A flashing 10 according to a first embodiment will now be described with reference to Figs. 1 to 7. The flashing 10 is arranged on a building 1. The flashing 10 of the present embodiment is arranged below an exterior part 8 in order to prevent rainwater flowing on the exterior part 8 from moving to the lower surface of the exterior part 8.

[0014] The building 1 is, for example, a house that includes a building body 2. The building body 2 includes a roof 2A and an outer wall 3. The roof 2A includes a roof surface 2B that is parallel to or inclined with respect to the horizontal direction. The building 1 further includes an outdoor living space 4. Examples of the outdoor living space 4 include a terrace, a balcony, and a veranda.

[0015] As shown in Figs. 2 and 3, the roof 2A includes lateral members 5A that are horizontally arranged, rafters 5B that are directly or indirectly supported on the lateral members 5A, receiving members 5C that are respectively arranged on the rafters 5B, and a roof foundation 5D supported by the receiving members 5C. A roofing material is covered on the roof foundation 5D.

[0016] In one example, the roof 2A projects out of the outer wall 3 to cover the outdoor living space 4. Examples of the outdoor living space 4 include a terrace, a balcony, and a veranda. In such a roof 2A, one or more lateral members 5A are arranged above the outdoor living space 4. In the present embodiment, one lateral member 5A (hereinafter referred to as an outer lateral member 6) of the lateral members 5A that support the roof 2A is arranged above the outdoor living space 4. The portion of the roof 2A facing the floor surface of the outdoor living space 4 is closed by a cover member 7.

[0017] The space between the outer lateral member 6 and the outer wall 3 is closed by a first cover member 7A. The first cover member 7A is arranged to cover a lower surface 6A of the outer lateral member 6. The space between a side surface 6B of the outer lateral member 6 and an eaves edge member 2C is closed by a second cover member 7B.

[0018] The second cover member 7B is located at a higher position than the first cover member 7A. More specifically, the second cover member 7B is arranged such that its lower surface intersects the side surface 6B of the outer lateral member 6. The lower part of the side surface 6B of the outer lateral member 6 is located at a lower position than the second cover member 7B. The side surface of the outer lateral member 6 is covered by the exterior part 8. The exterior part 8 is preferably formed using a finishing material that is waterproof and light-resistant. Examples of the finishing material include a siding and a tile. The exterior part 8 is attached to the outer lateral member 6 by a furring strip 9. A ventilation passage VP through which air passes is provided between the exterior part 8 and the outer lateral member 6. The flashing 10 is arranged below the exterior part 8. The flashing 10 prevents the rainwater on the exterior part 8 from moving to the outer lateral member 6 via the lower surface of the exterior part 8. Further, the flashing hides the lower surface of the exterior part 8, thereby improving the design of the lower surface of the roof 2A, which projects on the upper side of the outdoor living space 4.

[0019] Referring to Fig. 4, the main component of the flashing 10 is a flashing member 11. The flashing member 11 includes an attachment portion 12 and a guide 13. The attachment portion 12 is used to attach the flashing member 11 to the building 1. The guide 13 guides water. The flashing member 11 is made of, for example, metal. Examples of the metal include metal that can be easily machined at a construction site. In one example, the metal of which the flashing member 11 is made is aluminum or aluminum alloy.

[0020] The flashing member 11 is fixed to the outer lateral member 6 by fixing the attachment portion 12 to the outer lateral member 6 using a screw. More specifically, the attachment portion 12 is arranged in the ventilation passage VP between the exterior part 8 and the outer lateral member 6 in a state where the flashing member 11 is arranged below the exterior part 8. The body of the attachment portion 12 includes a first main surface 12A and a second main surface 12B. The body of the attachment portion 12 is, for example, plate-shaped. At least a part of the first main surface 12A faces the exterior part 8 in the state where the flashing member 11 is arranged below the exterior part 8. At least a part of the second main surface 12B faces the outer lateral member 6 in the state where the flashing member 11 is arranged below the exterior part 8.

[0021] The guide 13 is spaced apart from the lower surface of the exterior part 8 in the state where the flashing member 11 is arranged below the exterior part 8. The body of the guide 13 includes a first main surface 13A and a second main surface 13B. The body of the guide 13 is, for example, plate-shaped. The first main surface 13A of the guide 13 is continuous with the first main surface 12A of the attachment portion 12. The second main surface 13B of the guide 13 is continuous with the second main surface 12B of the attachment portion 12. Angle θ , formed by the first main surface 12A and the first main surface 13A, is preferably greater than or equal to 90° . Angle θ , formed by the first main surface 12A and the first main surface 13A, is preferably less than or equal to 120° .

[0022] The flashing member 11 further includes an extension 14. The extension 14 is continuous with the guide 13. The extension 14 prevents the water flowing on the first main surface 13A of the guide 13 from flowing to the second main surface 13B of the guide 13. More specifically, the attachment portion 12 is arranged at one end of the guide 13 in the width direction and the extension 14 is arranged at the other end. Further, in the state where the flashing member 11 is arranged below the exterior part 8, the extension 14 is configured to extend downward from the end of the guide 13 opposite the portion where the attachment portion 12 is arranged.

[0023] The flashing member 11 includes a coupling portion 20. The flashing member 11 is used to couple the flashing member 11 to an additional flashing member 111. The additional flashing member 111 has the same components as the flashing member 11. The coupling portion 20 is arranged at least on the first main surface 13A of the guide 13. In the present embodiment, the coupling portion 20 is further arranged on the first main surface 12A of the attachment portion 12.

[0024] The coupling portion 20 includes a retainer 21 that retains a coupling member 30. In a state where the flashing member 11 is coupled to the additional flashing member 111 by the coupling member 30, the retainer 21 is configured such that the second main surface 13B of the guide 13 of the flashing member 11 is flush with a second main surface 113B of a guide 113 of the additional flashing member 111.

[0025] The retainer 21 includes a first protrusion 22 that protrudes from the first main surface 13A of the guide 13 and a second protrusion 23 that protrudes from the first main surface 12A of the attachment portion 12. The first protrusion 22 extends in a longitudinal direction XA of the guide 13. The second protrusion 23 extends in the longitudinal direction XA of the attachment portion 12.

[0026] The first protrusion 22 includes a body 22A that protrudes from the first main surface 13A and a movement restricting portion 22B that is orthogonal to the longitudinal direction XA of the body 22A. The movement restricting portion 22B is parallel to the first main surface 13A. The second protrusion 23 is parallel to the first main surface 13A.

[0027] The first main surface 13A, the first protrusion 22, and the second protrusion 23 define a retaining space S that retains the coupling member 30. The flashing member 11 is coupled to the additional flashing member 111 by retaining a part of the coupling member 30 in the retaining space S of the flashing member 11 and retaining another part of the coupling member 30 in the retaining space S of the additional flashing member 111.

[0028] The coupling member 30 includes a body 31. The body 31 is a plate-shaped member including a first main surface 31A and a second main surface 31B. One of the first main surface 31A and the second main surface 31B contacts the movement restricting portion 22B of the first protrusion 22 and the second protrusion 23 during coupling. The other one of the first main surface 31A and the second main surface 31B contacts the first main surface 13A during coupling. The size of the body 31 is set according to the retaining space S.

[0029] The method for attaching the flashing 10 of the present embodiment will now be described with reference to Figs. 6 and 7.

A worker brings the attachment portion 12 of the flashing member 11 into contact with the side surface 6B of the outer lateral member 6 to fix the attachment portion 12 to the outer lateral member 6 using a screw. When the length of the flashing 10 including one flashing member 11 in the longitudinal direction XA is shorter than the length of the exterior part 8 in the horizontal direction, the worker couples the additional flashing member 111, which is separate from the flashing member 11. In such a manner, the length in the longitudinal direction XA is made longer. More specifically, a part of the coupling member

30 is inserted into the retaining space S defined by the first main surface 13A, the first protrusion 22, and the second protrusion 23 of the flashing member 11. Another part of the coupling member 30 protrudes from the flashing member 11. The portion of the coupling member 30 protruding from the retainer 21 is inserted into the retaining space S defined by the additional flashing member 111. It is preferred that the adhesive 40 be applied to the first main surface 31A or the second main surface 31B of the coupling member 30, which contacts the first main surface 13A of the guide 13. In the state where the flashing member 11 is coupled to the additional flashing member 111 by the coupling member 30, the second main surface 13B of the guide 13 of the flashing member 11 is flush with the second main surface 113B of the guide 113 of the additional flashing member 111. Further, the first main surface 12A of the attachment portion 12 is flush with the first main surface 112A of the attachment portion 112 of the additional flashing member 111. The attachment portion 112 of the additional flashing member 111 is fixed to the side surface 6B of the outer lateral member 6 using a screw.

[0030] When the length of the flashing 10, including the flashing member 11 and the additional flashing member 111, in the longitudinal direction XA does not match the length of the exterior part 8 in the horizontal direction, the lengths are adjusted using the following means. When the length of the flashing 10, including the flashing member 11 and the additional flashing member 111, in the longitudinal direction XA is shorter than the length of the exterior part 8 in the horizontal direction, the length in the longitudinal direction XA is made longer by coupling a further additional flashing member 111. When the length of the flashing 10, including the flashing member 11 and the additional flashing member 111, in the longitudinal direction XA is greater than the length of the exterior part 8 in the horizontal direction, a part of the flashing member 11 or the additional flashing member 111 is cut using, for example, an electric saw. Such a means is used so that the length of the flashing 10

in the longitudinal direction XA matches the length of the exterior part 8 in the horizontal direction.

[0031] The operation of the flashing 10 the present embodiment will now be described.

When strong wind or the like blows, the rainwater in contact with the exterior part 8 contacts the first main surface 13A of the guide 13 and moves to the extension 14 to fall downward. The configuration of the guide 13 and the extension 14 prevents the rainwater in contact with the exterior part 8 from contacting the outer lateral member 6. In addition, the arrangement of the guide 13 of the flashing 10 below the opening of the lower end of the ventilation passage VP prevents the rainwater from reaching the inside of the ventilation passage VP.

[0032] The advantages of the flashing member 11 of the first embodiment will now be described.

(1) The flashing member 11 is arranged below the exterior part 8 of the building 1. The flashing member 11 includes the coupling portion 20 that is coupled to the additional flashing member 111, which is separate from the flashing member 11.

The flashing 10 of the present embodiment includes the coupling portion 20 that couples the flashing member 11 to the additional flashing member 111. Thus, when the flashing member 11 and the flashing member 111 are arranged below the exterior part 8, one of the flashing member 11 and the flashing member 111 can be easily positioned relative to the other one.

[0033] (2) The coupling portion 20 includes the retainer 21 that retains the coupling member 30 for coupling of the flashing member 11. The retainer 21 of the flashing member 11 and the retainer of the additional flashing member 111 retain the coupling member 30 so as to couple the flashing member 11 to the additional flashing member 111.

The flashing 10 of the present embodiment allows one of the flashing member 11 and the flashing member 111 to be easily positioned relative to the other one when the flashing member 11 and the flashing member 111 are arranged below the exterior part 8.

[0034] (3) The coupling member 30 is bonded to the coupling portion 20 using the adhesive 40.

The flashing 10 of the present embodiment increases a coupling force of the coupling member 30. When the adhesive 40 has a sealing effect, the gap formed between the coupling member 30 and the coupling portion 20 is sealed. This prevents the rainwater in contact with the first main surface 13A of the guide 13 from flowing through the gap to the second main surface 13B.

[0035] (4) In the state where the flashing member 11 is coupled to the additional flashing member 111, the second main surface 13B of the flashing member 11 is flush with the second main surface 113B of the additional flashing member 111.

The flashing 10 of the present embodiment includes no gap between the flashing member 11 and the additional flashing member 111 and thus has an improved design.

[0036] (5) The flashing member 11 is made of aluminum.

In the flashing 10 of the present embodiment, the flashing member 11 is made of aluminum. In a case where the flashing member 11 is coupled to the additional flashing member 111, the length of the exterior part 8 in the horizontal direction may be longer than the length of the flashing members coupled to each other in the longitudinal direction XA. This may lower the appearance and the flashing effect. However, the flashing member 11 is made of aluminum and thus can be easily cut.

[0037] Second Embodiment

A flashing 100 according to a second embodiment will now be described with reference to Figs. 8 and 9. The flashing 100 of the second embodiment includes a first

flashing member 211 and a second flashing member 311. Like or the same reference numerals are given to those components that are like or the same as the corresponding components of the flashing member 11 of the first embodiment. Explanation of such components may be partially or entirely omitted.

[0038] The first flashing member 211 includes at least one of a first coupling portion 20A or a second coupling portion 20B. The second flashing member 311 includes at least the other one of the first coupling portion 20A or the second coupling portion 20B. In the present embodiment, the first flashing member 211 includes the first coupling portion 20A, and the second flashing member 311 includes the second coupling portion 20B. The first coupling portion 20A and the second coupling portion 20B are couplable to each other.

[0039] The first coupling portion 20A is arranged on a third main surface 213C of a guide 213. The third main surface 213C connects a first main surface 213A and a second main surface 213B of the first flashing member 211 to each other at an end of the first flashing member 211 in the longitudinal direction XA. The first coupling portion 20A has a projected shape that protrudes from the third main surface 213C.

[0040] The second coupling portion 20B is arranged in a third main surface 313C. The third main surface 313C connects a first main surface 313A and a second main surface 313B of the second flashing member 311 to each other at an end of the second flashing member 311 in the longitudinal direction XA. The second coupling portion 20B has a recessed shape recessed from the third main surface 313C.

[0041] As shown in Fig. 8, when the first flashing member 211 is coupled to the second flashing member 311, for example, the first flashing member 211 is moved so as to couple the first coupling portion 20A of the first flashing member 211 to the second coupling portion 20B of the second flashing member 311. When the first flashing member 211 is coupled to the second flashing member 311, the adhesive 40 may be applied to one of the

first coupling portion 20A and the second coupling portion 20B. As shown in Fig. 9, in a state where the first flashing member 211 is coupled to the second flashing member 311, the first coupling portion 20A and the second coupling portion 20B are configured such that a first main surface 212A of an attachment portion 212 is flush with a first main surface 312A of an attachment portion 312. In the state where the first flashing member 211 is coupled to the second flashing member 311, the first coupling portion 20A and the second coupling portion 20B are configured such that a second main surface 213B of the guide 213 is flush with a second main surface 313B of the attachment portion 313. Further, in the state where the first flashing member 211 is coupled to the second flashing member 311, the first coupling portion 20A and the second coupling portion 20B are configured such that a first main surface 213A of the guide 213 is flush with a first main surface 313A of the attachment portion 313.

[0042] The flashing 100 of the second embodiment provides the following advantages.

(6) The flashing 100 includes the first flashing member 211 and the second flashing member 311, which is separate from the first flashing member 211. The first flashing member 211 includes at least the first coupling portion 20A. The second flashing member 311 includes at least the second coupling portion 20B. The first coupling portion 20A of the first flashing member 211 is couplable to the second coupling portion 20B of the second flashing member 311. Alternatively, the second coupling portion 20B of the second flashing member 311 is couplable to the first coupling portion 20A of the first flashing member 211.

[0043] The flashing 100 of the present embodiment allows one of the flashing member 211 and the second flashing member 311 to be easily positioned relative to the other one when the flashing member 211 and the second flashing member 311 are arranged below the exterior part 8.

[0044] (7) The first coupling portion 20A of the present embodiment is arranged on the third main surface 213C. The second coupling portion 20B is arranged in the third main surface 313C. Since the coupling portion 20 is not provided on the first main surface 213A or the first main surface 313A, the first main surface 213A is flush with the first main surface 313A during coupling. When the first main surface 213A is configured to be flush with the first main surface 313A in the state where the first flashing member 211 is coupled to the second flashing member 311, the surface defined by the first main surface 213A and the first main surface 313A does not include an obstacle that hinders the flow of water. This limits situations in which the water flowing on the flashing 100 remains on the first main surface 213A and the first main surface 313A. Thus, the function of the flashing 100 is improved.

[0045] Modifications

The description of the embodiments is an exemplification of the mode that the flashing member according to the present invention can take, and is not intended to limit the mode. In addition to the embodiments, the flashing member according to the present invention can take, for example, a mode in which the following modifications of each embodiment are combined and a mode in which at least two modifications that remain consistent each other are combined.

[0046] In the first embodiment, the second protrusion 23 may be arranged on the first main surface 13A of the guide 13. In this case, the second protrusion 23 includes a body and a movement restricting portion in the same manner as the first protrusion 22.

[0047] In the first flashing member 211 of the second embodiment, the first coupling portion 20A may be arranged on a third main surface 213C that is provided at one end of the first flashing member 211 in the longitudinal direction XA, and the second coupling portion 20B may be arranged on a third main surface 213C that is provided at the other end of the

first flashing member 211 in the longitudinal direction XA. Since one first flashing member 211 includes the first coupling portion 20A and the second coupling portion 20B, flashing members can be easily coupled to each other in the case of extension in the longitudinal direction XA.

[0048] In the building 1, the target on which the flashing 10 is arranged is not limited to the examples of the present embodiment. For example, the flashing 10 may be arranged below the exterior part of the vertical wall of a veranda. The flashing 10 may be arranged below the exterior part of the wall of a bay window. The flashing may be arranged below the exterior part of a hanging wall that protrudes from the outer wall of the building 1.

REFERENCE SIGNS LIST

- [0049]** 1) Building
- 8) Exterior Part
 - 10) Flashing
 - 11) Flashing Member
 - 20) Coupling Portion
 - 20A) First Coupling Portion
 - 20B) Second Coupling Portion
 - 21) Retainer
 - 30) Coupling Member
 - 40) Adhesive
 - 111) Additional Flashing Member
 - 211) First Flashing Member
 - 311) Second Flashing Member

CLAIMS

1. A flashing member arranged below a roof of a building, the roof including an outer lateral member, an exterior part covering a side surface of the outer lateral member, and a furring strip attaching the exterior part to the outer lateral member, a ventilation passage through which air passes being provided between the exterior part and the outer lateral member, the flashing member comprising:

an attachment portion arranged in the ventilation passage;

a guide for guiding water, the guide being continuous with the attachment portion;

and

a coupling portion that is coupled to an additional flashing member, the additional flashing member being separate from the flashing member, wherein

at least a part of the attachment portion faces the exterior part, and

the guide is spaced apart from a lower surface of the exterior part.

2. The flashing member according to claim 1, wherein

the coupling portion includes a retainer that retains a coupling member for coupling of the flashing member, and

the retainer of the flashing member and the retainer of the additional flashing member retain the coupling member so as to couple the flashing member to the additional flashing member.

3. The flashing member according to claim 2, wherein the coupling member is bonded to the coupling portion using an adhesive.

03 12 24

4. The flashing member according to any one of claims 1 to 3, wherein a predetermined surface of the flashing member is flush with a predetermined surface of the additional flashing member in a state where the flashing member is coupled to the additional flashing member.

5. The flashing member according to claim 1, wherein
the flashing member includes a first flashing member and a second flashing member, the second flashing member being separate from the first flashing member,
the first flashing member includes at least a first coupling portion,
the second flashing member includes at least a second coupling portion, and
the first coupling portion of the first flashing member is couplable to the second coupling portion of the second flashing member or the second coupling portion of the second flashing member is couplable to the first coupling portion of the first flashing member.

6. The flashing member according to any one of claims 1 to 5, wherein the flashing member is made of aluminum.