



- (51) **International Patent Classification:**
E06B 3/66 (2006.01) *E06B 3/30* (2006.01)
E04D 13/035 (2006.01) *E06B 7/14* (2006.01)
E06B 3/263 (2006.01)
- (21) **International Application Number:**
PCT/DK2009/050031
- (22) **International Filing Date:**
3 February 2009 (03.02.2009)
- (25) **Filing Language:** English
- (26) **Publication Language:** English
- (71) **Applicant (for all designated States except US):** **VKR HOLDING A/S** [DK/DK]; Breettevej 18, DK-2970 Hørsholm (DK).
- (72) **Inventors; and**
- (75) **Inventors/Applicants (for US only):** **KRISTENSEN, Lars** [DK/DK]; Søndermarken 25, DK-8752 Østbirk (DK). **NIELSEN, Kristian Ørnsvig** [DK/DK]; Skovgården, Bøgeskovvejen 18, DK-8783 Hornslyd (DK). **SØNDERKÆR, Peter** [DK/DK]; Poststien 1, Haldrup, DK-8700 Horsens (DK).
- (74) **Agents:** **ROHDE, Vibeke** et al.; Awapatent A/S, Rigersgade 11, DK-1316 København K (DK).
- (81) **Designated States (unless otherwise indicated, for every kind of national protection available):** AE, AG, AL, AM, AO, AT, AU, AZ, BA, BB, BG, BH, BR, BW, BY, BZ, CA, CH, CN, CO, CR, CU, CZ, DE, DK, DM, DO, DZ, EC, EE, EG, ES, FI, GB, GD, GE, GH, GM, GT, HN, HR, HU, ID, IL, IN, IS, JP, KE, KG, KM, KN, KP, KR, KZ, LA, LC, LK, LR, LS, LT, LU, LY, MA, MD, ME, MG, MK, MN, MW, MX, MY, MZ, NA, NG, NI, NO, NZ, OM, PG, PH, PL, PT, RO, RS, RU, SC, SD, SE, SG, SK, SL, SM, ST, SV, SY, TJ, TM, TN, TR, TT, TZ, UA, UG, US, UZ, VC, VN, ZA, ZM, ZW.
- (84) **Designated States (unless otherwise indicated, for every kind of regional protection available):** ARIPO (BW, GH, GM, KE, LS, MW, MZ, NA, SD, SL, SZ, TZ, UG, ZM, ZW), Eurasian (AM, AZ, BY, KG, KZ, MD, RU, TJ, TM), European (AT, BE, BG, CH, CY, CZ, DE, DK, EE, ES, FI, FR, GB, GR, HR, HU, IE, IS, IT, LT, LU, LV, MC, MK, MT, NL, NO, PL, PT, RO, SE, SI, SK, TR), OAPI (BF, BJ, CF, CG, CI, CM, GA, GN, GQ, GW, ML, MR, NE, SN, TD, TG).

[Continued on next page]

(54) **Title:** A WINDOW HAVING A SASH AND AN IMPROVED CONNECTION TO THE HINGE

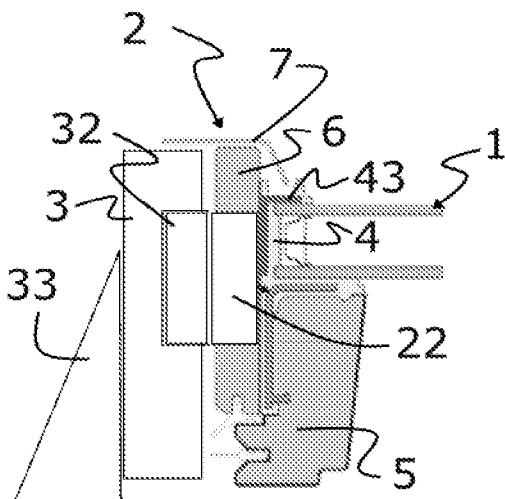

Fig. 2c

(57) **Abstract:** The window for a building structure has a window frame (3), a sash (2) and a pane (1) including at least one sheet of glass or other glazing material. The sash (2) is moveable relative to the frame (3) by means of a hinge connection including a set of frame hinge parts (32) and a set of sash hinge parts (22). The sash (2) carrying the pane (1) includes at least a first element (4) surrounding the pane (1) and formed as a moulded border element which at least partially encases an edge of the pane (1). The first element (4) has at least one functional face to which the set of sash hinge parts (22) of the hinge connection is adapted to be connected. The sash (2) may include further elements (5, 6, 7, 8) for insulating, covering and/or aesthetical purposes.

WO 2010/088904 A1

Published:

— *with international search report (Art. 21(3))*

A window having a sash and an improved connection to the hinge

The invention relates to a window for a building structure, comprising a window frame, a sash and a pane including at least one sheet
5 of glass or other glazing material, said sash being moveable relative to the frame by means of a hinge connection including a set of frame hinge parts and a set of sash hinge parts, said sash carrying the pane, said sash including at least a first element surrounding the pane and formed as a moulded border element which at least partially encases an edge of
10 at least one sheet of said pane, said first element having at least one functional face.

When glazing vertical windows as well as roof windows the pane is usually secured to a glass-carrying frame, i.e. traditionally the sash, by means of glazing profiles fastened to the frame by means of screws.
15 The pane is kept in place by means of glass spacers and glazing clips. Though it has proven very efficient this method suffers from a number of disadvantages, among others the large number of different parts needed for the glazing and the fact that the discontinuous support may cause potentially destructive strains on the pane, particularly when using a
20 conventional glass sheet pane. This influences the lifespan of the pane with respect to breakage and failure in the sealing, the latter resulting in the formation of condensation in the space between the two sheets of glass constituting the pane.

One attempt at overcoming these deficiencies is disclosed in
25 published European patent application No. EP 0 384 482 A2.

It is the object of the invention to provide a window, in which the manufacture is more cost-effective and flexible, and which provides a secure and reliable connection between the individual parts of the window.

30 This and further objects are achieved by a window of the kind mentioned in the introduction, which is furthermore characterized in that the set of sash hinge parts of the hinge connection is adapted to be connected to said first element at a functional face thereof.

By providing for connection of the sash hinge parts directly to

the first element of the sash the window may be manufactured with the use of fewer parts than what is needed for conventional glazing, as there is thus no need for further structural elements for transmitting the load from the pane into the fixed building structure. By moulding the pane and the element required to fulfil the tasks of the sash in one operation, this design of the window allows for a particularly cost-effective and flexible manufacture, as the first element may be designed taking mainly or only structural considerations into account.

In a preferred embodiment, said sash includes at least one further element, said at least one further element being connected to the first element at a functional face. This provides for a great flexibility in designing and custom-making the sash to the demands made, for instance on individual markets, in order to fulfil regulations, architectonic traditions or consumer requirements with respect to insulating properties, appearance, protection against weather conditions etc.

In a further development of the preferred embodiment, said at least one further element includes a second element positioned on the inner side and/or internal side of the first element. The second element is thus the one visible from the interior, i.e. the inside of the building room in which the window is installed. The second element may thus be designed with any properties desirable, without having to take structural considerations into account. Additionally, the second element may have insulating properties to increase the overall thermal efficiency of the window.

In one embodiment, which is particularly advantageous as regards the insulating properties, said at least one further element includes an insulating element positioned on the outer side of the first element. As this further element is in general not visible from the interior, at least not in the closed or only slightly opened condition of the window, and does not necessarily contribute to the structural strength of the sash, a material for the insulating element may be chosen only to optimise the insulating properties of the window. In turn, this opens a considerably increased choice in materials, as most insulating materials have a low density and consequently a lower structural strength.

In yet another embodiment, said at least one further element includes an external element positioned on the external side of the first element. The external element may be formed as a traditional cover connected to the exterior functional face of the first element of the sash.

5 The cover may provide additional shielding against the penetration of weathering to interior parts of the window, or may be chosen to adapt the window to the surroundings, for instance in cases where the window is utilised as a replacement window in an array of conventional windows.

In a further development, which is particularly applicable in areas requiring a high degree of insulation and soundproofing, said at least one further element includes an internal element positioned on the internal side of the first element, said internal element including a supplemental sheet of glazing material.

10

The window may be any kind of window applicable within the building area, i.e. fulfilling the particular requirements to windows to be installed in fixed constructions, including any geometrical configuration. In a preferred embodiment, said sash comprises a top piece, a bottom piece and two side pieces, and wherein said set of sash hinge parts is connected to the first element of the side pieces of the sash.

15

In one embodiment, each sash hinge part is integrally connected with the first element of the sash. Preferably, the integral connection is carried out in the same process step as the moulding of the first element to the pane, for instance by positioning the sash hinge parts at the appropriate places in the mould. Alternatively, the hinge parts may be connected integrally in any other manner.

20

25

Alternatively, each sash hinge part is adapted to be connected to a mounting fitting moulded into the first element of the sash. This makes it possible to utilize the same pane-sash constellation in a number of applications having different requirements as to the particular design of the hinge.

30

Thus, the hinge connection may include a traditional pivot hinge for positioning at a position along the side pieces of e.g. a roof window, the hinge of a top-hung window, pivot hinges included in special arrangements, for instance positioned farther away from the light-

admitting aperture, or on an intermediate frame allowing pivoting of a top-hung window.

Although the first element of the sash is only required to transmit the forces via the hinge connection, further arrangements including load-transmission may be applicable. In one embodiment, the top piece of the sash is provided with a locking assembly. In another embodiment, the bottom piece of the sash is provided with operating means for opening, positioning and/or closing of the sash relative to the window frame.

In windows adapted for the building area, condensation may arise, which must be avoided or alleviated. In one embodiment, the pane comprises at least two sheets, the first element encasing the edges of both sheets of the pane substantially in full, and wherein draining means are provided.

The drain may include a channel extending from the edge of the pane to the outer side of the first element of the sash. Alternatively, the drain may include a gel located in a space within the first element of the sash. As a further alternative, a circumferential drain extending along the edge of the pane and within the first element of the sash.

In one embodiment, in which the insulating properties of the window are increased, the window frame is provided with a supplemental insulating frame.

Although the connection between the pane and the sash, viz. the first element moulded to the edge of the pane, is reliable and sufficient for most applications, taking modern materials and manufacturing processes into account, there may arise a need or desire for supplemental protection against the risk of loosening of the pane with respect to the sash. In one embodiment, which takes care of these considerations, a support is provided in the first element of the sash, said support being moulded into the first element and overlapping the external side of the pane slightly. By means of the support, a mechanical securing of the pane is achieved.

In windows, in which the sash comprises a top piece, a bottom piece and two side pieces, the support is provided on at least two opposite side pieces of the sash or at the top piece and the bottom piece of

the sash. By positioning the support at least on sash pieces opposite each other, or even on all four pieces, a positive engagement between the pane and the sash is ensured at all times.

The support may be formed of any suitable material, which is preferably fireproof. In one preferred embodiment, the support is connected to the set of sash hinge parts. In this manner, a connection between the pane and the window frame via the hinge connection is maintained, even in the case of fire entailing partial or full melt-down or at least deterioration of the structural properties of the sash.

In a further development of the preferred embodiment, in which at least one further element is connected to the first element, each said further element is advantageously detachably connected to first element. In this manner, the parts of the sash may be exchanged for new parts, or extra elements may be mounted subsequently, for instance for maintenance purposes.

In the following, the invention will be described in further detail with reference to the drawing in which:

Fig. 1 is a perspective view of a window according to the invention;

Figs. 2a to 2g are cross-sectional views taken along the line II-II in Fig. 1 of different embodiments of the window shown in Fig. 1;

Fig. 3 is a cross-sectional view taken along the line III-III of Fig. 1;

Fig. 4 is a cross-sectional view taken along the line IV-IV of Fig. 1;

Fig. 5 is a perspective view of another window according to the invention;

Figs 6a to 6c are cross-sectional views taken along the line VI-VI in Fig. 5 of three different embodiments of the window shown in Fig. 5.

A window according to the invention is shown in Fig. 1. The window comprises a pane element 1 (referred to as pane in the following), a sash 2 and a window frame 3 for installation in a building structure (not shown). The building structure may be any kind of suitable roof

surface or a façade of a fixed construction. Thus, the window is a building window to be installed vertically or inclined in the façade or the roof of any residential, office or industrial building. The sash 2 is connected to the window frame 3 by means of a hinge connection defining a hinge axis, in a manner to be described in further detail below. The sash 2 comprises a top piece, a bottom piece and two side pieces, and the set of sash hinge parts is connected to the first element of the side pieces of the sash. In the following the side pieces, top piece and bottom piece of the sash and frame, respectively, will be denoted throughout by reference numerals 2 and 3, respectively.

Referring now in general to the embodiments of the window shown in Figs 2a to 2g, each window comprises a sash 2 including a first element 4 surrounding the pane 1 and formed as a moulded border element. In the embodiments shown in Figs 2a to 2d, the sash 2 includes a second element 5.

The first element or border element 4 creates a structural joint to the pane 1, thereby rendering the glazing profiles etc. formerly used redundant. In the embodiments shown in Figs 2a to 2e, the first element 4 surrounds the entire border of the pane and encases an edge of both sheets of the pane 1 on all four pieces of the sash 2, but it is to be understood that it may also be U-shaped surrounding the pane on three of its four sides or that separate elements may be used on each side leaving the corners of the pane free or connected to tailor-made corner pieces. Similarly it is to be understood that windows with other geometrical configurations, i.e. semi-circular or triangular, are also conceivable. In the embodiment of Fig. 2f, the first or border element 4 only surrounds the external sheet 11 of the pane 1, whereas in the embodiment of Fig. 2g, only one sheet exists, thus constituting the pane 1 itself.

The first element 4 is preferably made by moulding it directly on the pane 1, either with both sheets congruently or separately. If the pane 1 is a finished pane element comprising the predefined number of sheets (two, three, ...), the entire pane element is positioned in the mould. If, on the other side, the multi-sheet pane 1 is formed in two or more steps, then the first sheet 11 is attached to the first element 4 by

the moulding process and the second sheet is then connected to the first sheet thereby forming a two-sheet pane 1. Further sheets may, if desirable, be connected in a corresponding manner. Subsequently, the space between the first element 4 and the edge of the pane may be sealed by
5 caulking, cf. the description of Fig. 2f below. Polyurethane is a preferred moulding material. In principle, a pane module consisting of the pane 1 and the first element 4 thus forms the sash 2 itself and fulfils the function of a structural element bearing the loads affecting the window. The remaining element or elements of the sash 2 may therefore be formed
10 with any desired properties as regards insulation, soundproofing, protection, covering, or even taking into account aesthetical considerations. Any suitable material, such as wood, plastic, polyurethane or polyurethane with a wooden core, can be used for the manufacture of the remaining elements of the sash 2.

15 The first element 4 may be produced by using any suitable moulding technique, but injection moulding, e.g. reaction injection moulding (RIM), is preferred. When using the RIM process, current-carrying components, plastic or metal components contributing to strength and stiffness, screws etc. may be embedded in the moulding
20 material. Furthermore, the RIM process allows the integration of details such as sealings. Reaction injection moulding (RIM) is a process that is well known per se. During moulding, a two-component curing polyurethane is mixed in the mould. In the mould a pressure of approximately 6 to 10 bar is obtained during the curing process. The cured item is ready
25 to be handled within approximately 45 to 60 seconds. During the RIM process itself the temperature of the material and the mould lies between 80 and 110°C depending on the configuration of the mould and whether the polyurethane used is of the aromatic or the aliphatic kind. According to the kind of polyurethane used different Shore A hardness
30 may be obtained. In the example, polyurethane having a cured hardness of 60-90 Shore A may be used.

It is of course also possible to perform the moulding in other ways, e.g. at higher temperature and/or pressure, which may be necessary when using other materials than polyurethane. Using a single-

component material, which is injected into the mould without the need for mixing is another option.

As the unit formed by the first element or border element 4 as the substantial parts of the sash 2 functions as a structural member itself, a set of sash hinge parts 22; 122; 222 of the hinge connection is adapted to be connected directly to the first element 4 at a functional face thereof, viz. in the embodiment shown to the outer surface facing away from the light-admitting aperture covered by the pane 1. The hinge connection may be formed as any hinge connection suitable for openable windows. In the embodiment of Figs 2a, 2c, and 2e, the hinge connection may for instance formed as a traditional pivot hinge used in roof windows. One example of such a hinge connection is disclosed in Applicant's European patent No. 1038083. The corresponding set of frame hinge parts 32 is mounted in the window frame 3, preferably but not necessarily in a recess formed in the inner side of each of the window frame side pieces.

The embodiment of Fig. 2d shows a fourth embodiment of the window according to the invention and incorporating a hinge connection disclosed in Applicant's international application WO 2007/028392. Each frame hinge part 32 is secured to the surface of the window frame piece facing away from the sash piece or, alternatively, in a recess formed in an upper surface of the frame side piece, in which the side facing the surrounded aperture is substantially unaffected by the recess, and wherein the sash hinge part 22 is connected to the sash side piece 4 via a connecting piece spanning at least a part of the frame piece substantially crosswise to the longitudinal direction of the frame piece 3. In the embodiment shown, the connecting piece and the sets of frame and sash hinge parts constitute a substantially U shaped unit, in which a first leg of the U including or constituted by the sash hinge part 22 is substantially perpendicular to the hinge axis and projects into the recess or along the surface of the frame facing away from the surrounded aperture, where the centre of the U is substantially parallel to the hinge axis and spans a part of the frame piece 3, and where a second leg 24 of the U is secured to the sash, the centre leg 23 and second leg being formed

by the connecting piece.

A further alternative embodiment of the hinge connection is shown in Figs 2b and 2f. Here, each sash hinge part is adapted to be connected to a mounting fitting 122 moulded into the first element 4 of the sash 2. This provides for a flexible choice of hinge connections, which may be of any kind suitable. In order to secure retention of the mounting fitting 122 into the first element 4 of the sash 2, anchoring means 122a are provided. The anchoring means 122a may be formed as flanges extending in various directions in any of the three dimensions, i.e. lengthwise along the sash side piece 2, transverse from the outer to the inner, and/or in the height direction, i.e. from the internal to the external. Correspondingly, the sash hinge part 22 of a traditional pivot hinge may be secured into the sash 2 by providing the sash hinge part 22 with anchoring means. Referring now to Fig. 6b, such anchoring means 22a are indicated in the sash side piece 2. The provision of anchoring means, which may be formed integrally with the mounting fitting and the sash hinge part itself, or as one or more separate elements connected to the hinge part, provides an additional security against unintentional de-attachment of the hinge from the sash.

In all of the above embodiments, the set of hinge parts of the hinge connection may be located at suitable opposite positions of for instance the side pieces of the window frame and sash, or at the top or bottom pieces, respectively, of the window frame and sash. Furthermore, the hinge axis being positioned arbitrarily along for instance the side pieces. In a traditional pivot window, the sets of hinge parts are positioned centrally; however, a position closer to the top piece or bottom piece is conceivable as well, for instance for the purpose of obtaining a larger available opening, if the window is to be used as a rescue exit.

In a not-shown embodiment, the sash is connected to the window frame by means of an intermediate frame connected to the window frame at the top piece window frame by means of an additional set of hinges, and wherein the sash is hingedly connected to the frame by means of said set of sash hinge parts, the set of frame hinge parts being mounted on said intermediate frame. In this manner, the window is of

the top-hinged type having a hinge axis at or close to the top of the window. However, due to the intermediate frame, the sash is able to pivot for instance for cleaning purposes. Examples of this type of window are shown in for instance European patent applications 733146 and
5 1873323.

Eventually, the set of sash hinge parts may be formed as a simple pin 222 as shown in the embodiment of Fig. 2g. The pin 222 is moulded into the first element 4 and is adapted to be received in a corresponding aperture of a hinge fitting mounted to the frame, for instance
10 centrally or at the top of the window frame.

Figs 2a and 2b show two different embodiments of the sash side pieces 2. The first or border element 4 is moulded around the pane 1 enclosing it on the edge and interior faces. "Interior" in this respect denotes the direction, which in the installed position of the window points in-
15 wards into the building. At an interior functional face of the first element 4, a further element sash element in the form of second element 5 is attached. The second element 5 is shown as being of a rectangular configuration, but it is to be understood that more complex configurations may be necessary for carrying out any features desirable, for instance
20 for achieving a water proof connection to the structure in which the window is mounted or to the surrounding window frame, for insulating considerations, or for aesthetical purposes.

A fitting 41, 42 is embedded in the first or border element 4 during its manufacture and is subsequently connected to the second
25 element 5. When using a wooden or extruded second element 5, the fitting may be driven into the second element and when using a moulded second element 5, the fitting may be embedded therein during moulding. In the latter case an I-shaped fitting (not shown) may be used to thereby increase the draw out resistance.

30 If the adhesion of the first element 4 to the second element 5 is particularly strong and stable, the fitting 41, 42 may be left out entirely. This may be achieved by an appropriate priming of the area of attachment on the frame.

The use of a moulded sash comprising more elements in addi-

tion to the compulsory first element 4 provides a particularly secure connection, but it necessitates the use of a mould that is large enough to hold at least both the first element 4 of the sash 2 and the pane 1.

Attachment of the first or border element to the glass sheet is achieved purely by the adhesive properties of the moulding material and is established during the moulding process. To achieve good adhesion the areas of attachment on the pane may be covered by a mask and/or be primed. The masking has the further purpose of contributing to the aesthetic value of the window and to protect adherents and the pane sealing 13 from sunlight. The mask is generally lightproof but must as a minimum be non-transparent for UV-A and UV-B light. The mask may be a ceramic coating, UV hardening lacquer, a one- or two-component lacquer or any other suitable material. It is to be understood that priming and masking may be achieved in one by the use of a material having properties suitable for both purposes.

However, for security reasons, for instance for the purposes of fire protection, a mechanical support may supplement the fastening provided by the moulding of the first or border element to the pane. One example of such a support is shown in Figs 2c, 2e to 2g, and 6c, but similar supports may be present in the other embodiments as well. The support 43 may be formed of any suitable material, which is preferably fireproof. One example is a metal rod that has been bent into the desired shape. In this manner, a connection between the pane and the window frame via the hinge connection is maintained, even in case the remaining material is burnt or melted, or if the structural and load-bearing capacity is deteriorated partly or in full. As a supplementary securing against deterioration of the sash 2 in the case of fire, a fire resistant or fire retardant filler may be mixed into the moulding material of the first element 4.

The provision of a second element 5 and further elements in the sash 2, in addition to the first element 4 moulded to the pane 1, may be chosen in correspondence with for instance different market requirements as to insulating properties, weather resistance and appearance. In the following, a limited but not exhaustive number of further elements

will be described.

In Fig. 2c, which describes an embodiment, which is particularly advantageous as regards the insulating properties, said at least one further element includes an insulating element 6 positioned on the outer side of the first element 4. As this further element is in general not visible from the interior, at least not in the closed or only slightly opened condition of the window, and is not required to contribute to the structural strength of the sash, a material for the insulating element may be chosen only to optimise the insulating properties of the window. In turn, this opens a considerably increased choice in materials, as most insulating materials have a low density and consequently a lower structural strength. Furthermore, an external element 7 positioned on the external side of the first element 4 is provided. The external element 7 may be formed as a traditional cover connected to the exterior functional face of the first element of the sash. The cover may provide additional shielding against the penetration of weathering to interior parts of the window, or may be chosen to adapt the window to the surroundings, for instance in cases where the window is utilised as a replacement window in an array of conventional windows. In order to increase the insulating capacity even further, the window frame 3 is provided with a supplemental insulating frame 33.

In Fig. 2e, which shows a further development, which is particularly applicable in areas requiring a high degree of insulation and sound-proofing, said at least one further element includes an internal element 8 positioned on the internal side of the first element 4, said internal element 8 including a supplemental sheet 14 of glazing material. The internal element 8 may for instance be connected to the first element 4 by a protruding flange 4a thereof extending into a recess 8a of the interior element 8. The first element 4 may have a supplemental rod-shaped attachment part 45, cf. also the embodiment of Fig. 2g, and the corresponding part 245 of the embodiment of Fig. 6c.

The number and configuration of further elements may vary, and several combinations and further developments of the examples given in the above are conceivable. One example is the provision of an

external element including a supplemental sheet positioned externally of the pane 1. Such an external element may be provided with ventilation means, either passive means or active means sucking air from the outdoors. The internal element 8 may be provided with ventilation means as well.

Referring now to Figs 3 and 4, showing cross-sectional views of the window shown in Fig. 1 in the embodiment corresponding to Fig. 2c. Although the first element 2 of the sash is only required to transmit the forces via the hinge connection, further arrangements including load-transmission may be applicable. In one embodiment, the top piece 2 of the sash is provided with a locking assembly 42 for cooperation with corresponding means 52 in the frame top piece 3. In another embodiment, the bottom piece of the sash 2 is provided with operating means 62 for opening, positioning and/or closing of the sash relative to the window frame, the operating means being connected to a window operator 72 mounted in the bottom frame piece 3.

The first element 4 may be connected to the second element 5 and any other further elements by means of any detachable or undetachable connecting means. Examples of detachable connecting means are screws, nails or other mechanical connection means, e.g. a click-system. Examples of undetachable connecting means are moulding (for instance in the same process step as the moulding of the first element to the pane), glue or adhesives. Examples of click systems are shown in Figs 6a and 6b.

In Fig. 6a the first or border element 4 encases the exterior glass sheet 11, the distance profile and pane sealing unit 13, as well as the interior glass sheet 12. A fitting 76 embedded in the first element 4 has a tongue 77 with a barb 78, which engages with a catcher 79 on the second element 5. As in the above embodiment and the embodiments to be described in the following the pane element includes glass sheets, which may be parallel or non-parallel plane sheets, or sheets having an arbitrary shape.

The system depicted in Fig. 6b corresponds to the one in Fig. 6a as regards the overall configuration of the pane 1, first element 4, and

second element 5. In this case, however, the second element 5 is provided with a fixation bushing 89 arranged to engage with a hole 88 in the projecting part 87 of the fitting 86. By turning the fixation bushing over 180 degrees, the tongue is engaged or disengaged. A screw 90 is used for fastening the bushing 89 in the second element 5 upon engagement of the tongue.

The connection between the first element and the frame is made in a manner that creates a watertight connection or at least so that moisture and water may be drained off in a controlled manner.

10 In the embodiment of Fig. 6a, one example of providing a durable protection against the penetration of water is shown. A sealing strip 44 of any suitable material, for instance butyl rubber, is moulded into a nose portion 4b of the first element 4. The sealing strip 44 thus covers the outer corner of the external sheet 11.

15 Additional draining means may, however, be required. Referring still to Figs 6a to 6c, the design of three different draining techniques will be described further:

In Fig. 6a, a channel 46 extends from the edge of the pane 1 to the outer side of the first element 4 of the sash 2. In this manner, water penetrating through any sealings and covers may be safely drained from the pane edge.

20 In Fig. 6b, the drain includes a gel 147a located in a space 147 within the first element of the sash. The gel 147a is able to absorb water during humid conditions, and to allow the water to evaporate during dry spells.

In Fig. 6c, the drain includes a circumferential drain 246 extending along the edge of the pane 1 and within the first element 4 of the sash 2. The circumferential drain 246 may be provided with a number of openings 246a to allow entry of water into the circumferential drain 246.

30 In this embodiment, a gasket 248 is furthermore provided between the interior glass sheet 12 and the second element 5 for relieving the border of the pane and for draining off condensation forming on the inside of the pane, preventing it from reaching the first element 4 and pane sealing/spacer profile 13. The sash 2 in this embodiment furthermore com-

prises a tongue-like weather strip 249 formed integrally during the moulding for tightening the space between the sash 2 and the window frame (not shown in this Figure). Additional draining may be provided by a projecting feather, preferably running along the entire length of the first element. The feather will prevent water from running from the exterior surface of the pane into the space between the sash and the window frame. At the lower end of the window the feather should be left out or interrupted to allow rainwater and the like to drain off unobstructed.

The pane is usually composed of monolithic glass sheets, in the embodiments of Figs 2a to 2f forming two sheets 11 and 12. In this context the term "monolithic glass" covers annealed glass, tempered glass, laminated glass, wired glass, figured or patterned glass as well as other types of glass that are used in conventional panes. Even if referred to as being made from glass, it is to be understood that Plexiglas (also known as Perspex) or any other sheet of glazing material, transparent or not, which is suited for the particular use of the window, may also be employed, including luminescent materials. Referring to Fig. 2f, the glass may have coatings on one or both sides. When making a step unit pane in this manner, a space 16 remains between the first or border element and edge of the non-encased glass sheet, allowing the introduction of a caulking device for the purpose of establishing a secondary pane sealing. The weight of the pane depends on a number of factors, including the choice of material, the size of the window, the number of sheets and the thickness of the individual sheets. These parameters are chosen in accordance with a number of factors, including the degree of insulating properties desired, both as regards soundproofing and thermal insulation. In a mid-size window having two sheets of glass, the weight of the pane 1 and the sash 2 may be 10-20 kg, whereas the corresponding sash-pane unit of a window having three sheets of glass may amount to above 25 kg. Conversely, in a window having a glazing consisting solely of a lightweight plastic material, the weight may be as low as 2-5 kg.

The cavity between the sheet elements may be filled with dry air, gas such as Ar, Kr or Xe, or with gas mixtures suitable for improving the insulating properties of the pane by reducing its U value. A vacuum

pane may also be used as may a pane with a layer of aerogel filling the space between the sheet elements.

The pane may be a conventional type pane, where all sheet elements have identical size and shape, or may be a step unit. Step units
5 are panes, where the different glass sheets have different height and/or width so that one sheet projects over another at least at one edge thereof. Also panes comprising three or more sheet elements, such as for example three-sheet thermo panes, may be used as may combinations of different pane types such as a traditional thermo pane in combination with a single sheet pane.
10

If using a pane type that can best be made in relatively small units, such as vacuum panes, a series of pane elements may be arranged side-by-side for the formation of a larger element of the desired size. This method may also be used for providing different areas of the
15 pane with different properties such as colour, opacity, insulation etc.

The distance profiles or spacer members may be made from metal or plastic. A desiccant may be deposited in hollow distance profiles, embedded in a matrix or in a getter element in each of the cavities delimited by the glass sheets and the distance profiles. This may be carried out as a part of the pane module manufacture or the different elements may be pre-manufactured. Moreover, the distance profile may be provided with additional functionalities, such as sound dampening features, or additional members providing such functionalities may be provided in between the sheet elements of the pane(s).
20

The pane may be a conventional type pane, in which all glass sheets have identical size and shape, or may be step units. Step units are panes, where the different glass sheets have different height and/or width so that one sheet projects over another at least at one edge thereof.
25

A two-sheet pane may be constructed simultaneously with the moulding of the first element, in which case the distance profile may be made as an integral part of the first element or border element. The same applies if combining different pane types such as a two-sheet pane with a single-sheet pane; the two-sheet pane may then for example be
30

made in a traditional manner whereas the distance member keeping it apart from the single-sheet pane may be a moulded projection on the border element. Either type of distance profile may be provided with projecting fittings or other means of attachment to the border element.

5 Although the invention described in the above and shown in the drawings is referred to as a window, the invention is applicable to other closures for apertures in a building structure. Such closures may comprise panels including solar cells, photovoltaic elements etc. As indicated in Fig. 5 of the drawing a ventilation device 10 may be incorporated into
10 the pane 1. The ventilation device 10 may be powered by for instance solar cells or photovoltaic elements in the pane 1, and be operated by control means moulded into the first element 4 or positioned elsewhere in the window.

 The invention should not be regarded as being limited to the
15 embodiments described and shown. Several modifications and combinations may be carried out within the scope of the claims.

P A T E N T C L A I M S

1. A window for a building structure, comprising a window frame (3), a sash (2) and a pane (1) including at least one sheet of glass or other glazing material, said sash being moveable relative to the frame by
5 means of a hinge connection including a set of frame hinge parts (32) and a set of sash hinge parts (22), said sash (2) carrying the pane (1), said sash (2) including at least a first element (4) surrounding the pane (1) and formed as a moulded border element which at least partially en-
10 (4) having at least one functional face, characterized in that the set of sash hinge parts (22) of the hinge connection is adapted to be connected to said first element (4) at a functional face thereof.

2. A window according to claim 1, wherein said sash (2) includes at least one further element (5,6,7,8), said at least one further
15 element being connected to the first element (4) at a functional face.

3. A window according to claim 2, wherein said at least one further element includes a second element (5) positioned on the inner side and/or internal side of the first element (4).

4. A window according to claim 2 or 3, wherein said at least one
20 further element includes an insulating element (6) positioned on the outer side of the first element (4).

5. A window according to any one of claims 2 to 4, wherein said at least one further element includes an external element (7) positioned on the external side of the first element (4).

25 6. A window according to any one of claims 2 to 5, wherein said at least one further element includes an internal element (8) positioned on the internal side of the first element (4), said internal element (8) including a supplemental sheet (14) of glazing material.

7. A window according to any one of the preceding claims,

wherein said sash (2) comprises a top piece, a bottom piece and two side pieces, and wherein said set of sash hinge parts (22;122;222) is connected to the first element (4) of the side pieces of the sash (2).

8. A window according to claim 7, wherein each sash hinge part
5 (22;222) is integrally connected with the first element (4) of the sash (2).

9. A window according to claim 7, wherein each sash hinge part is adapted to be connected to a mounting fitting (122) moulded into the first element (4) of the sash (2).

10 10. A window according to claim 7, wherein the each frame hinge part is secured to the surface of the window frame piece facing away from the sash piece or in a recess formed in an upper surface of the window frame side piece, in which the side facing the surrounded aperture is substantially unaffected by the recess, and wherein the sash
15 hinge part is connected to the sash side piece via a connecting piece spanning at least a part of the frame piece substantially crosswise to the longitudinal direction of the frame piece.

11. A window according to claim 10, wherein the connecting piece and the sets of frame and sash hinge parts constitute a substan-
20 tially U shaped unit, in which a first leg of the U including or constituted by the sash hinge part is substantially perpendicular to the hinge axis and projects into the recess or along the surface of the frame facing away from the surrounded aperture, where the centre of the U is substantially parallel to the hinge axis and spans a part of the frame piece,
25 and where a second leg of the U is secured to the sash, the centre and second leg being formed by the connecting piece.

12. A window according to claim 7, wherein the sash is connected to the window frame by means of an intermediate frame connected to the window frame at the top piece by means of an additional
30 set of hinges, and wherein the sash is hingedly connected to the intermediate frame by means of said set of sash hinge parts, the set of frame

hinge parts being mounted on said intermediate frame.

13. A window according to any one of claims 7 to 12, wherein the top piece of the sash (2) is provided with a locking assembly.

14. A window according to any one of claims 7 to 13, wherein
5 the bottom piece of the sash (2) is provided with operating means for opening, positioning and/or closing of the sash relative to the window frame.

15. A window according to any one of the preceding claims, wherein the pane (1) comprises at least two sheets, the first element
10 encasing the edges of both sheets of the pane substantially in full, and wherein draining means are provided.

16. A window according to claim 15, wherein the drain includes a channel extending from the edge of the pane (1) to the outer side of the first element (4) of the sash (2).

15 17. A window according to claim 15, wherein the drain includes a gel located in a space within the first element (4) of the sash (2).

18. A window according to claim 15, wherein the drain includes a circumferential drain extending along the edge of the pane (1) and within the first element (4) of the sash (2).

20 19. A window according to any one of the preceding claims, wherein the window frame (3) is provided with a supplemental insulating frame (33).

20. A window according to any one of the preceding claims, wherein a support (43) is provided in the first element (4) of the sash
25 (2), said support being moulded into the first element (4) and overlapping the external side of the pane (1) slightly.

21. A window according to claims 7 and 20, wherein the support (43) is provided on at least two opposite side pieces of the sash (2) or at

21

the top piece and the bottom piece of the sash (2).

22. A window according to claim 20 or 21, wherein the support (43) is connected to the set of sash hinge parts (22).

23. A window according to any one of claims 2 to 22, wherein
5 each said further element (5,6,7,8) is detachably connected to first element (4).

10

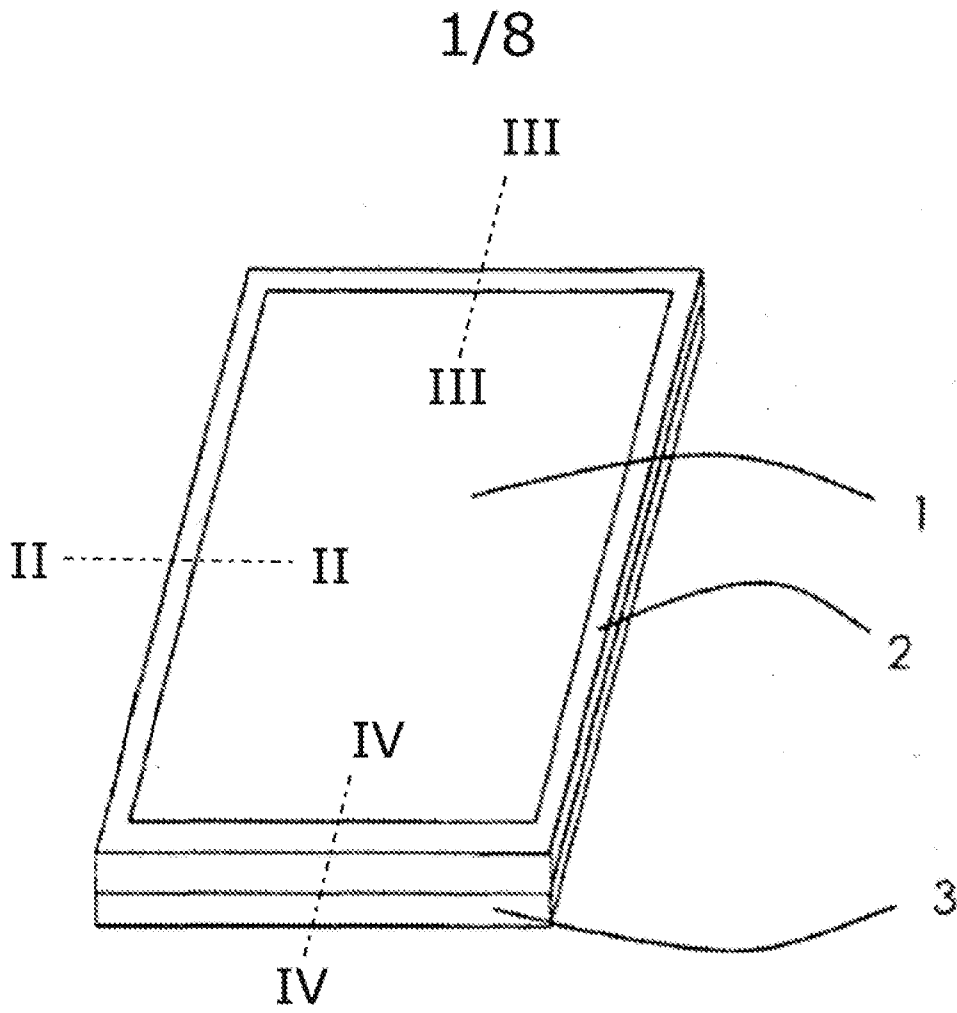

Fig. 1

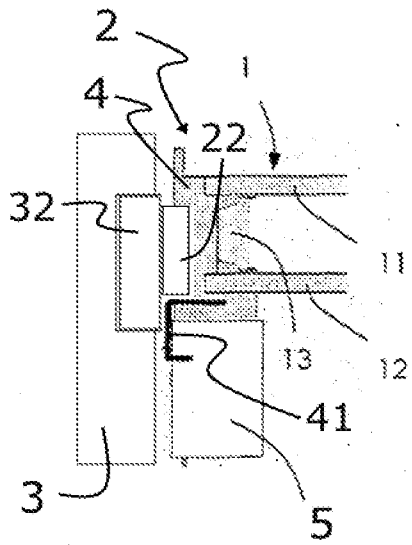

Fig. 2a

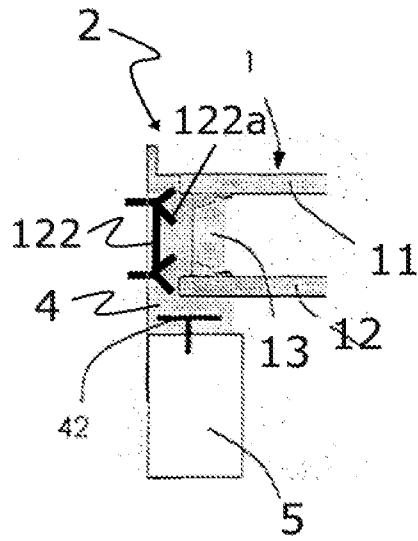

Fig. 2b

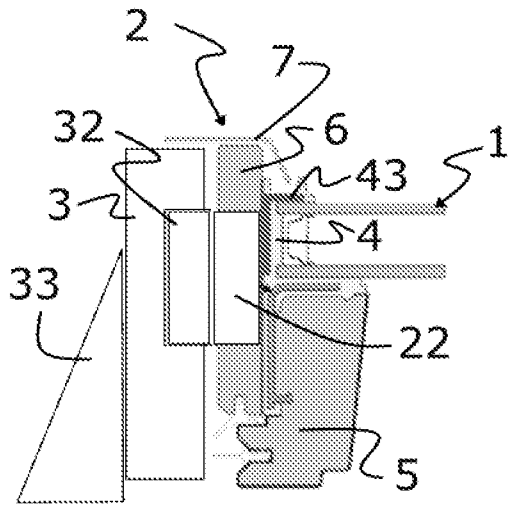

Fig. 2c

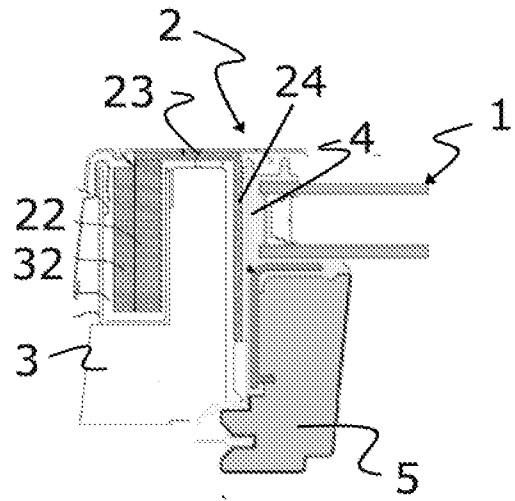

Fig. 2d

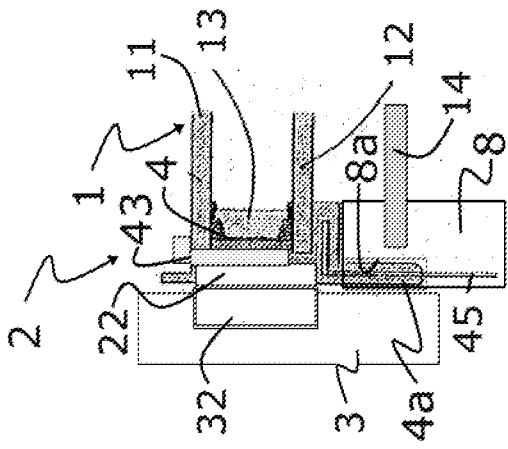

Fig. 2e

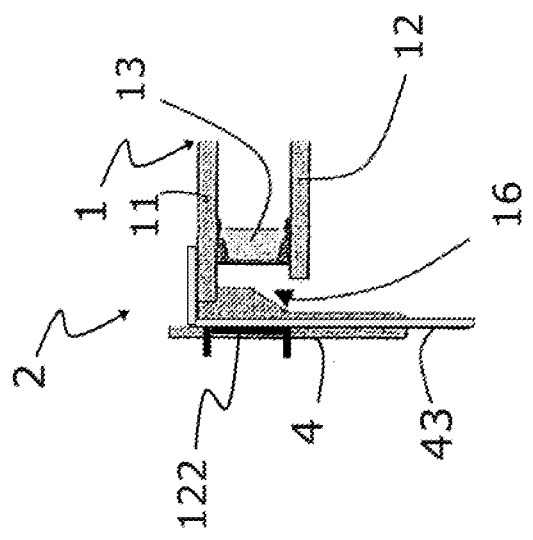

Fig. 2f

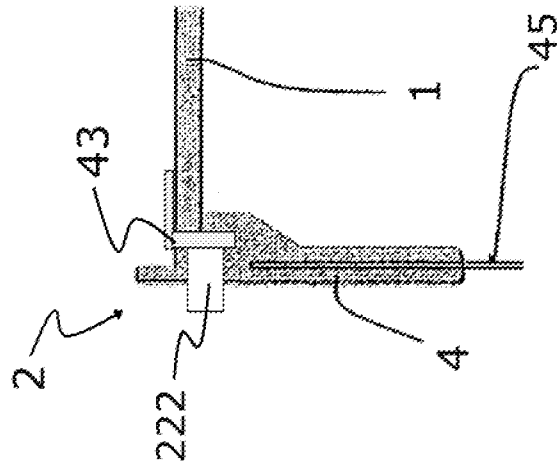

Fig. 2g

5/8

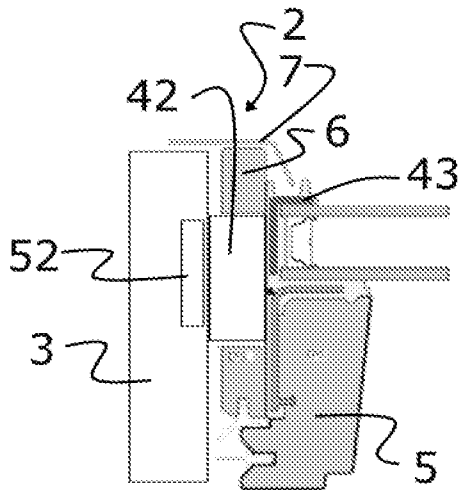

Fig. 3

6/8

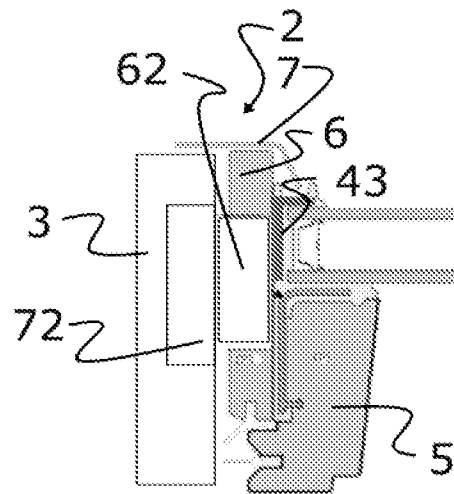

Fig. 4

7/8

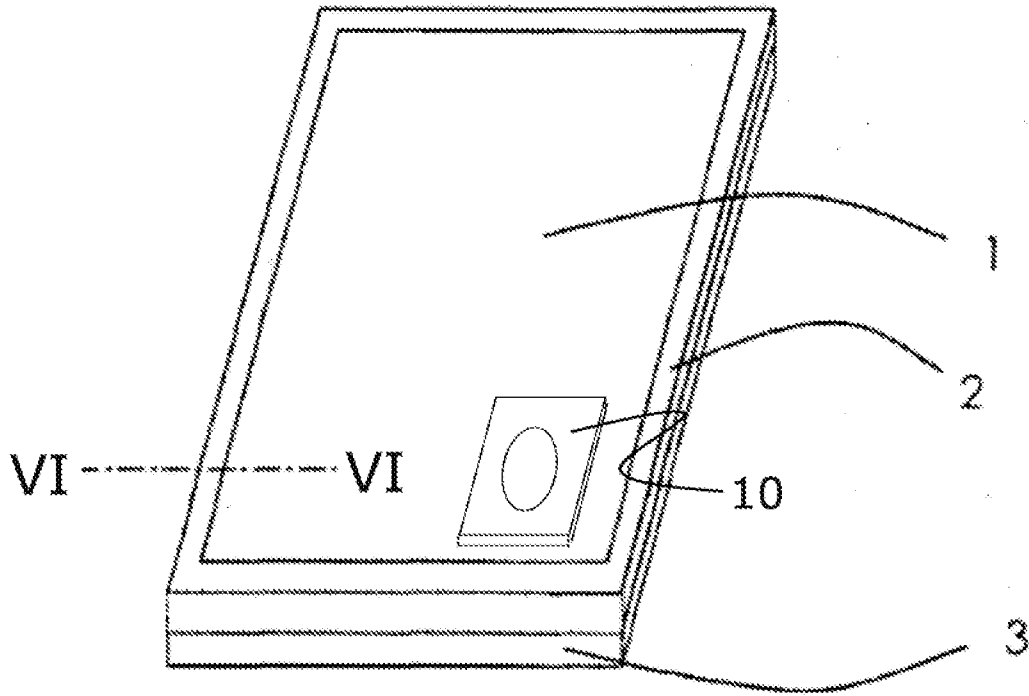

Fig. 5

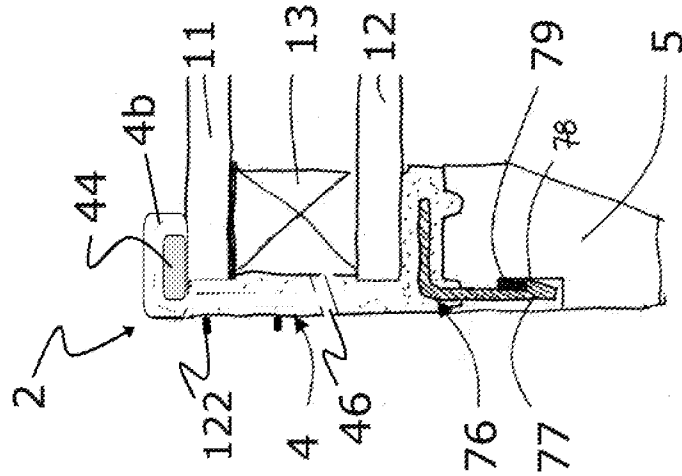

Fig. 6a

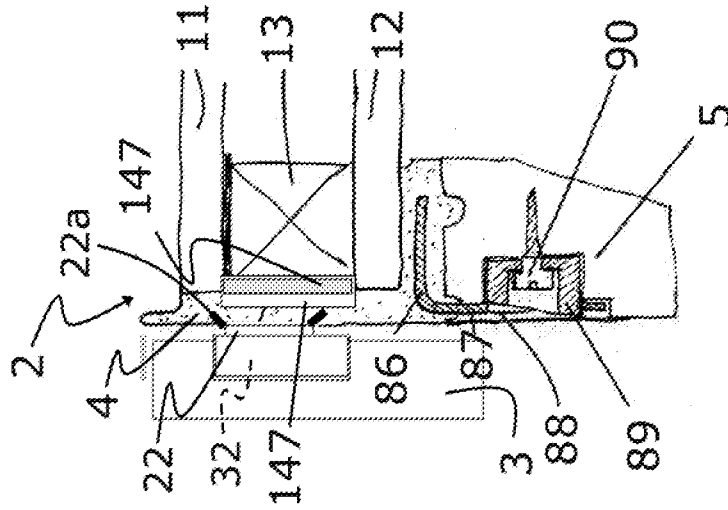

Fig. 6b

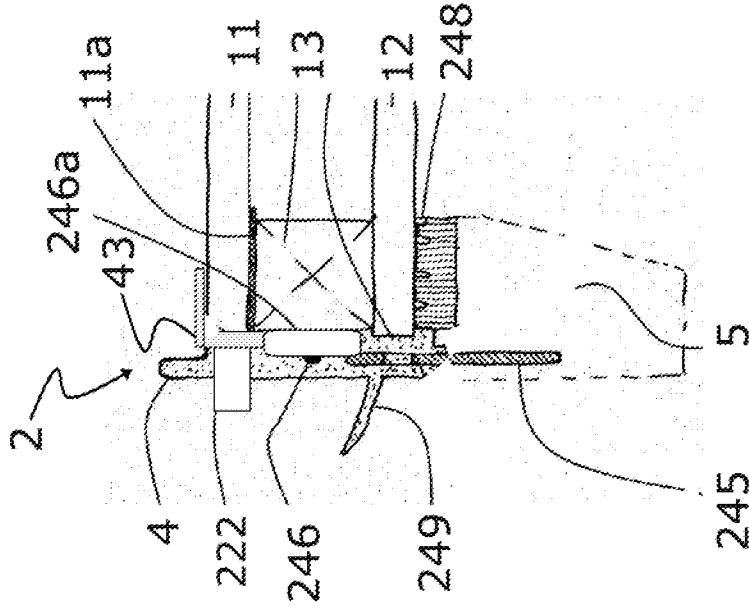

Fig. 6c

INTERNATIONAL SEARCH REPORT

International application No
PCT/DK2009/050031

A. CLASSIFICATION OF SUBJECT MATTER
 INV. E06B3/66 E04D13/035
 ADD. E06B3/263 E06B3/30 E06B7/14

According to International Patent Classification (IPC) or to both national classification and IPC

B. FIELDS SEARCHED
 Minimum documentation searched (classification system followed by classification symbols)
E06B E04D

Documentation searched other than minimum documentation to the extent that such documents are included in the fields searched

Electronic data base consulted during the international search (name of data base and, where practical, search terms used)
EPO-Internal

C. DOCUMENTS CONSIDERED TO BE RELEVANT

Category*	Citation of document, with indication, where appropriate, of the relevant passages	Relevant to claim No.
X	DE 296 07 923 U1 (VER GLASWERKE GMBH [DE]) 14 August 1996 (1996-08-14) figures 1,2	1-3,5
Y	claims 1,2	4,7-14
Y	----- CH 369 277 A (EBERSPAECHER J [DE]) 15 May 1963 (1963-05-15) figures 1,5 page 2, line 5 - line 10 page 2, line 39 - line 41	4
Y	----- WO 2007/028392 A (VKR HOLDING AS [DK]; EDVARDESEN ALLAN [DK]) 15 March 2007 (2007-03-15) cited in the application figures 2,4 page 8, line 25 - page 9, line 29 ----- -/-	7-12

Further documents are listed in the continuation of Box C. See patent family annex.

* Special categories of cited documents :

"A" document defining the general state of the art which is not considered to be of particular relevance	"T" later document published after the international filing date or priority date and not in conflict with the application but cited to understand the principle or theory underlying the invention
"E" earlier document but published on or after the international filing date	"X" document of particular relevance; the claimed invention cannot be considered novel or cannot be considered to involve an inventive step when the document is taken alone
"L" document which may throw doubts on priority claim(s) or which is cited to establish the publication date of another citation or other special reason (as specified)	"Y" document of particular relevance; the claimed invention cannot be considered to involve an inventive step when the document is combined with one or more other such documents, such combination being obvious to a person skilled in the art.
"O" document referring to an oral disclosure, use, exhibition or other means	"&" document member of the same patent family
"P" document published prior to the international filing date but later than the priority date claimed	

Date of the actual completion of the international search 23 February 2010	Date of mailing of the international search report 03/03/2010
--	---

Name and mailing address of the ISA/ European Patent Office, P.B. 5818 Patentlaan 2 NL - 2280 HV Rijswijk Tel. (+31-70) 340-2040, Fax: (+31-70) 340-3016	Authorized officer Tänzler, Ansgar
--	--

INTERNATIONAL SEARCH REPORT

International application No
PCT/DK2009/050031

C(Continuation). DOCUMENTS CONSIDERED TO BE RELEVANT		
Category*	Citation of document, with indication, where appropriate, of the relevant passages	Relevant to claim No.
Y	GB 2 005 330 A (REICHSTADT H U) 19 April 1979 (1979-04-19) figures 3,5 -----	13
Y	EP 1 691 000 A (WINKHAUS FA AUGUST [DE]) 16 August 2006 (2006-08-16) figures 1,2 -----	14
Y	EP 0 733 146 B (RASMUSSEN KANN IND AS [DK]) 11 June 1997 (1997-06-11) figure 1 -----	12

INTERNATIONAL SEARCH REPORT

International application No.
PCT/DK2009/050031

Box No. II Observations where certain claims were found unsearchable (Continuation of item 2 of first sheet)

This international search report has not been established in respect of certain claims under Article 17(2)(a) for the following reasons:

1. Claims Nos.:
because they relate to subject matter not required to be searched by this Authority, namely:

2. Claims Nos.:
because they relate to parts of the international application that do not comply with the prescribed requirements to such an extent that no meaningful international search can be carried out, specifically:

3. Claims Nos.:
because they are dependent claims and are not drafted in accordance with the second and third sentences of Rule 6.4(a).

Box No. III Observations where unity of invention is lacking (Continuation of item 3 of first sheet)

This International Searching Authority found multiple inventions in this international application, as follows:

see additional sheet

1. As all required additional search fees were timely paid by the applicant, this international search report covers all searchable claims.

2. As all searchable claims could be searched without effort justifying an additional fees, this Authority did not invite payment of additional fees.

3. As only some of the required additional search fees were timely paid by the applicant, this international search report covers only those claims for which fees were paid, specifically claims Nos.:

1-5, 7-14

4. No required additional search fees were timely paid by the applicant. Consequently, this international search report is restricted to the invention first mentioned in the claims; it is covered by claims Nos.:

Remark on Protest

- The additional search fees were accompanied by the applicant's protest and, where applicable, the payment of a protest fee.
- The additional search fees were accompanied by the applicant's protest but the applicable protest fee was not paid within the time limit specified in the invitation.
- No protest accompanied the payment of additional search fees.

FURTHER INFORMATION CONTINUED FROM PCT/ISA/ 210

This International Searching Authority found multiple (groups of) inventions in this international application, as follows:

1. claims: 1-5

A window sash with an insulating element

2. claim: 6

A window sash with a supplemental sheet of glazing material

3. claims: 7-14

A window sash with hinge parts

4. claims: 15-18

A window sash with draining means

5. claim: 19

A window frame with a supplemental insulating frame

6. claims: 20-22

A window sash with a support

7. claim: 23

A window sash with detachable means

INTERNATIONAL SEARCH REPORT

Information on patent family members

International application No

PCT/DK2009/050031

Patent document cited in search report	Publication date	Patent family member(s)	Publication date
DE 29607923	U1	14-08-1996	NONE
CH 369277	A	15-05-1963	NONE
WO 2007028392	A	15-03-2007	CN 101258297 A 03-09-2008 EA 200800761 A1 29-08-2008 EP 1760234 A1 07-03-2007 EP 1922466 A1 21-05-2008 JP 2009507152 T 19-02-2009
GB 2005330	A	19-04-1979	BE 870450 A1 02-01-1979 DE 2745192 A1 12-04-1979 FR 2405349 A1 04-05-1979 US 4217732 A 19-08-1980
EP 1691000	A	16-08-2006	AT 368778 T 15-08-2007 DE 102005002908 A1 27-07-2006 DK 1691000 T3 27-12-2007
EP 0733146	B	11-06-1997	AT 154411 T 15-06-1997 AU 1271695 A 27-06-1995 CN 1137306 A 04-12-1996 CZ 9601665 A3 13-11-1996 DE 69403814 D1 17-07-1997 DE 69403814 T2 22-01-1998 DK 138393 A 11-06-1995 WO 9516097 A1 15-06-1995 EP 0733146 A1 25-09-1996 ES 2105881 T3 16-10-1997 HU 75427 A2 28-05-1997 JP 3510259 B2 22-03-2004 JP 9506401 T 24-06-1997 PL 314871 A1 30-09-1996 RU 2126481 C1 20-02-1999 SK 71296 A3 09-04-1997 US 5689916 A 25-11-1997