

(No Model.)

H. B. POLKINHORN.

TABLET.

No. 302,774.

Patented July 29, 1884.

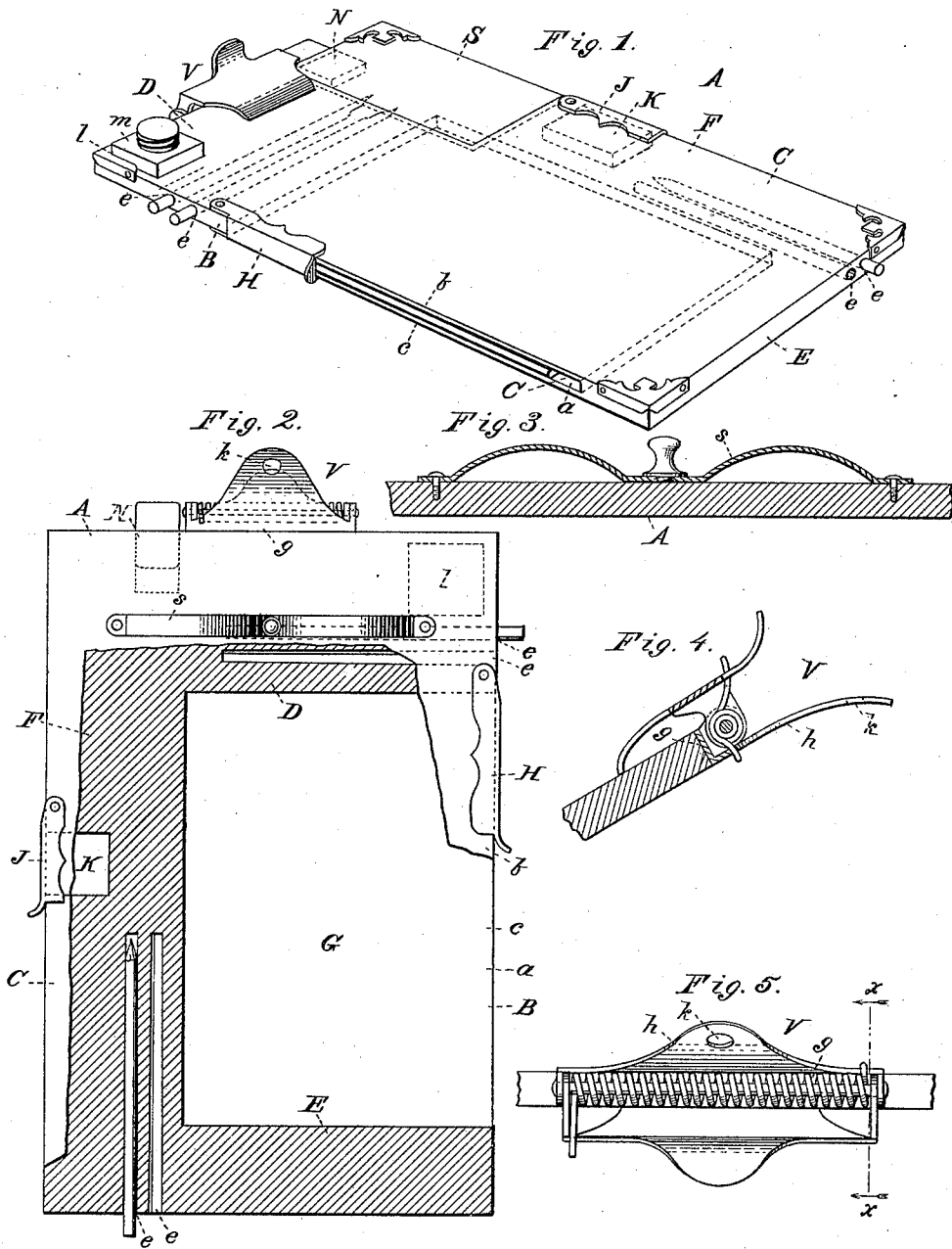

WITNESSES
Villette Anderson.
Philletasi.

INVENTOR
Henry B. Polkinhorn,
By Anderson & Smith
Lis Attorneys

UNITED STATES PATENT OFFICE.

HENRY B. POLKINHORN, OF WASHINGTON, DISTRICT OF COLUMBIA.

TABLET.

SPECIFICATION forming part of Letters Patent No. 302,774, dated July 29, 1884.

Application filed June 3, 1884. (No model.)

To all whom it may concern:

Be it known that I, HENRY B. POLKINHORN, a citizen of the United States, residing at Washington, in the District of Columbia, have invented certain new and useful Improvements in Portable Tablets; and I do declare the following to be a full, clear, and exact description of the invention, such as will enable others skilled in the art to which it appertains to make and use the same, reference being had to the accompanying drawings, and to letters or figures of reference marked thereon, which form a part of this specification.

Figure 1 of the drawings is a representation of this invention, and is a perspective view. Fig. 2 is a back view, partly in section. Fig. 3 is a cross-section of a portion of the tablet, showing the envelope-holder attached. Fig. 4 is a detail view showing the spring-clamp in section, taken on the broken line *xx* shown in Fig. 5. Fig. 5 is a detail view showing the spring-clamp on top.

This invention has relation to portable tablet-desks or lap-tablets; and it consists in the construction and novel arrangement of devices, as hereinafter set forth, and pointed out in the appended claims.

In the accompanying drawings, the letter A designates the tablet or desk, which may be made of wood, papier-maché, or other light material. It is a thin tablet of rectangular form, having its face and back plane. Its corners may be square, rounded, or beveled. In the tablet, between the face and back, is made a deep pocket, extending transversely from its opening at *a* in one of the lateral edges B of the tablet toward the other edge, C, thereof, the extension of the pocket being parallel to the face and back of the tablet. The upper wall, *b*, of the pocket is therefore thin, as is also the lower wall, *c*, thereof. At each end of the pocket the tablet is made or filled solid, as indicated at D and E, and along the edge C a solid portion, F, is left. The length and depth of the pocket G are usually sufficient to accommodate letter-paper, although it may sometimes be preferred to make the recess or pocket larger for cap-paper or smaller for note. The distance between the back wall, *c*, and the face-wall *b* is usually sufficient for the accommodation of a quire or

more of the paper. A clasp or fastener, H, is usually attached to the edge B of the tablet in such position that it may be closed over the opening or mouth of the pocket, and serve to keep the paper therein from casually slipping out. In the solid end portions, D and E, or preferably in the upper portion, D, are made long perforations *e e*, adapted to receive pencils or pen-holders, holding them by friction, and preventing them from being lost or injured. Usually these perforations are bored transversely, as shown; but sometimes it may be preferred to extend them longitudinally in the solid portion F along the edge C. In the solid side F, or in the solid end portion, is usually made a small recess, K, opening at the edge and provided with a cover, J. It is adapted to hold pen-points, and other edge recesses, as at N, may be made to hold pieces of rubber, postage-stamps, and other small articles.

S represents a silex-covered card, which is secured to the face of the tablet near one of its upper corners, preferably at the right hand, and recessed so that it will be even with the surface of the tablet.

V indicates a spring-clamp, having a flange, *g*, adapted to be secured to the upper edge of the tablet, and upon its upper portion a flange, *h*, having a perforation, *k*, so that the entire tablet may be hung up thereby when not in use.

In one of the upper corners, and preferably at the left-hand end of the solid portion D, is made a recess, *l*, adapted to receive a small inkstand, *m*, which is designed to be secured therein by cement or otherwise in any common manner. This inkstand is provided with a screw-cap or a spring-cap, or with some form of stopper which will, when the tablet is in upright position, prevent the ink from escaping.

To the under side of the tablet a spring-holder, *s*, may be attached, serving to hold envelopes; or the envelope-holding spring may be attached to the clamp V, or to an edge of the tablet.

Having described this invention, what I claim, and desire to secure by Letters Patent, is—

1. A tablet having parallel back and face, and between the same a transversely-extend-

ing paper-holding receptacle open at one edge, and provided with a suitable holding device, substantially as specified.

2. A tablet having rigid parallel back and face walls connected by solid end portions, and between said walls a transversely-extending pocket adapted to hold sheets of paper, and provided with a clasp on its edge to prevent the paper from slipping out, substantially as specified.

3. A tablet having parallel back and face, and paper-receptacle opening at the side, solid ends, and a solid side bored or recessed to form holding-seats for pencils, rubbers, &c., and an inkstand fixed in position at the head of the tablet, substantially as specified.

4. As an improved article of manufacture, the tablet having recesses opening at the edges thereof for the reception of writing material, a spring paper-holding clamp at the

head of the tablet, an inkstand-receptacle at one corner of the face-wall, and a silica card at the opposite corner, substantially as specified.

5. A tablet having its rear upper side provided with a spring-clamping device to serve the functions of holding envelopes, inclining the tablet and furnishing a spring-bearing for the same, substantially as specified.

6. The combination, with a tablet, of the paper-holding clamp, constructed as shown, having the flange *g*, adapted to be secured to the upper transverse edge of the tablet, substantially as and for the purposes specified.

In testimony whereof I affix my signature in presence of two witnesses.

H. B. POLKINHORN.

Witnesses:

JOHN A. CARR,
PHIL. C. MASI.