

A. WORTHINGTON.
 STEAM BOILER.
 APPLICATION FILED NOV. 17, 1909.

992,467.

Patented May 16, 1911.

2 SHEETS—SHEET 1.

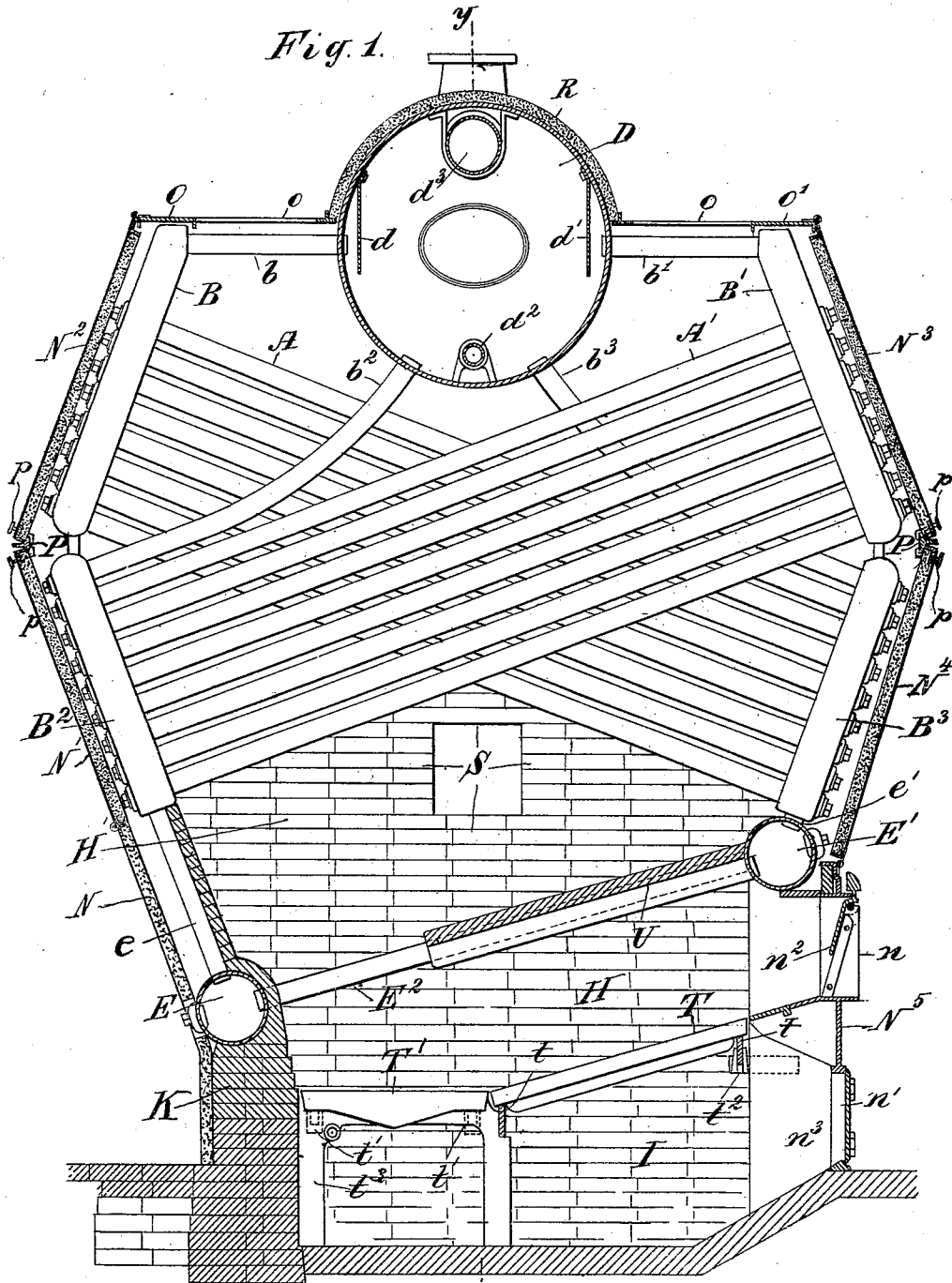

Witnesses:
S. H. Wiman
Grace T. Wilson

Inventor
Amasa Worthington
 By Attorney
W. H. Appleton

A. WORTHINGTON.
 STEAM BOILER.
 APPLICATION FILED NOV. 17, 1909.

992,467.

Patented May 16, 1911.

2 SHEETS—SHEET 2.

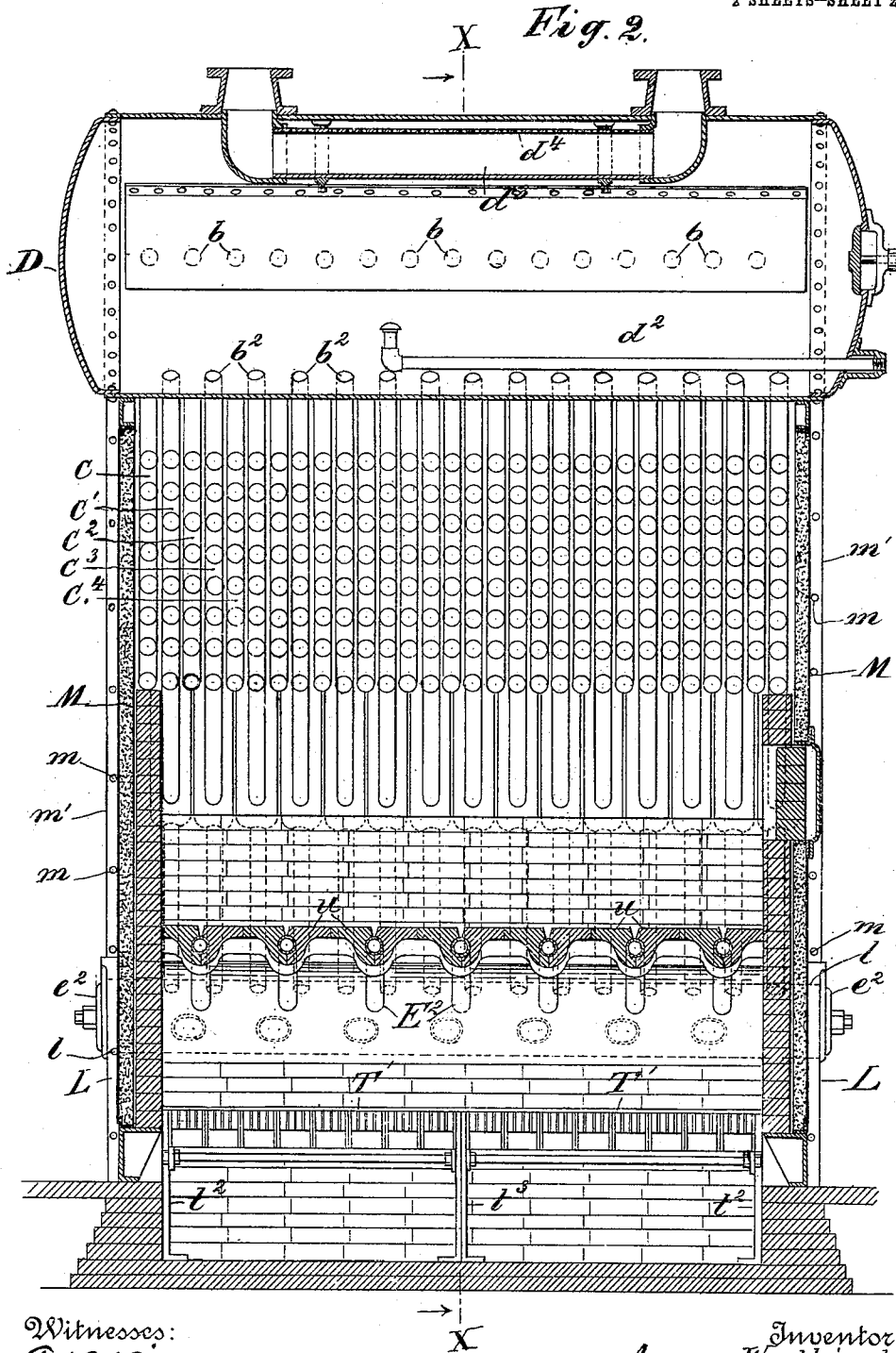

Witnesses:
S. H. Winson
Grace T. Clifton

Inventor
Amasa Worthington
 By
 Attorney
Wm. J. Appleton

UNITED STATES PATENT OFFICE.

AMASA WORTHINGTON, OF NEW YORK, N. Y.

STEAM-BOILER.

992,467.

Specification of Letters Patent.

Patented May 16, 1911.

Application filed November 17, 1909. Serial No. 528,550.

To all whom it may concern:

Be it known that I, AMASA WORTHINGTON, a citizen of the United States, and a resident of the borough of Brooklyn, in the county of Kings and city and State of New York, have invented a certain new and useful Improvement in Steam-Boilers, of which the following is a specification.

Although relating to steam boilers generally, my invention has reference more particularly to that form thereof which is known to the art as the "water-tube boiler," and in which the boiler is built up from a number of individual sections that are placed side by side and alternately inclined in opposite directions with respect to the horizon; its object being to provide a steam boiler of this class, in which, when in use, a more efficient circulation of water shall be effected through the mud-drums and through their tubular connections, and a more complete combustion of the fuel accomplished than is possible with boilers of this class as heretofore constructed.

To these ends my invention consists, first, in the peculiar combination of the mud-drums with their connecting tubes and with the water-tube sections, whereby the water in circulating through the boiler, instead of passing across from one mud-drum to the other in a single tube arranged in a horizontal direction at each of their ends, is caused to travel from one to the other in a plurality of tubes, which extend across above the fire-box at appropriate distances apart and incline upwardly from one drum to the other, and second, in the combination with the boiler and the fire-box thereof, of an improved deflector or baffle-plate, whereby the gases and other products arising from the combustion of the fuel, instead of passing upward directly to and between the water-tube sections, are, in their travel, deflected downwardly and rearwardly in an inclined direction and thereby more thoroughly commingled with the oxygen supplied to them before being carried upward in their course to and between those sections, all as will hereinafter more fully appear.

Referring to the accompanying drawings, which form a part of this specification, Figure 1, is a longitudinal vertical section of a water-tube boiler constructed in accordance with my invention, taken in the line $x x$ of Fig. 2, and Fig. 2 is a vertical trans-

verse section of the same, taken in the line $y y$ of Fig. 1.

In all the figures, like letters of reference are employed to indicate corresponding parts.

A and A^1 indicate the water-tubes, and B, B^1 , B^2 , and B^3 , the headers with which these tubes respectively cooperate. These water-tubes are preferably disposed in a number of series, with the individual tubes of each series arranged the one above the other in a vertical row, and are secured at their opposite ends in their appropriate headers, which are or may be constructed of rectangular or other convenient form in cross-section, and are provided with suitably-formed orifices in which the ends of the tubes enter and are expanded. As thus arranged these series of water-tubes A and A^1 constitute, with their respective headers, separate and independent sections C, C^1 , C^2 , etc., which, in the completed boiler, lie side by side throughout its length, with the sections made up from the respective series of tubes and their cooperating headers alternating with each other and inclined in opposite directions with respect to the horizon. In being thus disposed, these sections cooperate with a steam and water-drum D, which, located above and extending transversely of the various series of water-tubes, in a position opposite their longitudinal central portion, is connected with the respective headers B, B^1 , B^2 , and B^3 , by tubes b , b^1 , b^2 , and b^3 , which are secured at one of their ends in suitable orifices formed in the walls of the drum, and are confined at their opposite ends in appropriate orifices formed in their respective headers, with the tubes b and b^1 extended outward from the opposite side walls of the drum in a line passing through its axis, or slightly above the same, to the upper end portions of the headers B and B^1 , while the tubes b^2 and b^3 extend downward and outward from the walls of its under portion to the upper end portions of the headers B^2 and B^3 .

With the steam and water-drum D thus connected with the sections C, C^1 , C^2 , etc., the free and uninterrupted circulation of the water in the boiler, when the boiler is in use, is insured, as the cooler water in the drum is caused to flow downward from its lower portion through the tubes b^2 and b^3 to and through their respective headers B^2

and B³, thence upward through their coöperating tubes A and A¹, where it is heated, thence upward and through the respective headers B and B¹ to and through their connecting tubes *b* and *b*¹ to the upper portion of the drum, where it is discharged, and so on, the cooler water in the lower portion of the steam and water-drum passing downward to and through the respective tubes A and A¹, where it is heated, and thence upward to the drum in a continuous operation; and in order to break up the columns of water thus flowing through the tubes *b* and *b*¹ in effecting this circulation, whereby to release the steam entrained in them, I make use of baffle-plates *d* and *d*¹, against which these columns strike when discharged, and which, secured to the interior of the steam and water-drum, extend downward over the ends of the respective tubes *b* and *b*¹, as shown.

While the circulation of the water within the boiler is thus effected, the removal of all mud or other sediment set free in its operation is accomplished through the intervention of mud-drums E and E¹, into which this extruded material descends under the action of gravity, and from which it may be withdrawn when desired. To permit of the attainment of this end, these mud-drums are arranged transversely across the boiler beneath the various sections thereof, and are respectively connected with the headers B² and B³ through the medium of tubes *e* and *e*¹, which extend between them, and are secured at their opposite ends in suitable orifices formed respectively in the walls of the drums and the lower ends of the headers. As thus arranged and connected, an uninterrupted descent of the mud or other sediment set free in the operation of the boiler, downward into the drums E and E¹ is permitted through the tubes *e* and *e*¹, from which it may be removed through any appropriate means, as, for instance, through the ends of the drums, which may be closed by appropriate caps *e*²; and in order to prevent the drying or hardening of the mud or other sediment thus deposited and the injury to the drums by heat, these drums are connected by a series of tubes E², which, placed at the proper distance apart throughout their length, extend across from one to the other, whereby to insure of a free and uninterrupted circulation of water through them and the consequent maintenance of the mud or other sediment in condition for easy removal when desired.

In boilers of this class as heretofore constructed, these mud-drums when employed have usually been disposed at the same elevation, and have been connected at each of their ends to the corresponding end of the other by a single tube which was disposed in a horizontal plane, with the result that

the circulation of water through them, and through the mud-drums, has not been sufficient to prevent either the drying and hardening of the mud and other sediment deposited in them or injury to the mud-drums themselves from the heat to which they have been exposed. To obviate this objection, I not only connect these mud-drums by a series of water-tubes E² which extend across from one to the other at different points through their length, but I locate one of these mud-drums, as, for instance, the drum E¹ at or near the front of the boiler, at a somewhat higher elevation than the other, whereby to impart to the tubes E² extending between them an upward inclination, to the end that a more positive and efficient flow of the water through them, as it becomes heated, shall be insured.

With the parts connected and organized as above explained, the fire-box H, and its accompanying ash-pit I, are located beneath the series of water-tubes E². To permit of the fire-box and ash-pit being thus located, the boiler is supported at the proper elevation to allow of their interposition beneath it, by a pier K and standards L. Of these the pier K extends across the rear of the boiler and receives the mud-drum E, which rests upon its top, while the standards L are arranged upon its opposite ends near its front, and are provided with orifices *l* for reception of the ends of the mud-drum E¹, which are protruded through them, as shown. With the respective mud-drums thus resting upon the top of the pier K and within the orifices *l* of the standards L, a firm support for the boiler is afforded; and in order that the mud-drum E¹ may be disposed at the proper elevation above the mud-drum E to bring the parts of the boiler into proper operative position, the orifices *l* in the standards L are located in a higher level than is the top of the pier K, whereby to bring it into that position. In being thus employed to support the boiler, the pier K and standards L may be constructed of any appropriate materials. As shown in the drawings however, the pier K is built up of masonry, while the standards L are constructed of metal and in plate form, but these are merely illustrative, and other forms of material may be employed in their construction if so desired.

With the boiler constructed and supported as above described, it may be inclosed within any ordinary or preferred form of casing or setting. In the drawings however it is shown as inclosed within a casing made up from plates formed from cement, magnesia, or fire-felt, properly treated and firmly packed in pan-shaped sheet-metal backs, as illustrated and described in United States Letters Patent No. 524,878, which were granted to me August 21st, 1894, with the

lower portion of its front opposite the furnace and ash-pit constructed from a plate of cast or sheet-metal N^5 , as is common to boiler casings or settings as ordinarily constructed. When this form of casing is adopted, its opposite ends M , its back N , N^1 , and N^2 , and the upper portion of its front N^3 and N^4 , will be made up of plates having the proper shape and dimensions to suit them to their appropriate locations, in which the plates making up the ends M and the lower portion N of the back will be fixedly secured in place by appropriate rivets and flanges m and m^1 ; while the plates N^1 and N^2 constituting the upper portion of the back, and the plates N^3 and N^4 making up the upper portion of its front, will be secured in place by appropriate hinges, whereby to admit of access to the various headers when desired, with the plates N^1 and N^4 respectively hinged at their lower edges to the plates N and N^5 , while the plates N^2 and N^3 are respectively hinged at their upper edges to the plates O and O^1 . As thus hinged in place, the plates N^1 and N^2 at the back, and the plates N^3 and N^4 at the front, are arranged to rest at their respective meeting edges, when in their closed positions, against bars or girths P , in which positions they may be secured thereto by appropriate catches p , rotatively mounted in the inner edges of the plate, as shown. Although thus briefly described this form of casing constitutes no part of my present invention, but is merely illustrative of one of the many forms of settings or casings that may be adopted; and, when employed, the interior of the fire-box and other portions of the casing may be lined with fire-brick S or other heat resisting material, which, extending upward along the inner walls thereof to the required height along the sides and ends thereof, may inclose the mud-drum E and the inner surface of the series of water-tubes e if so preferred.

For separating the fire-box H from the ash-pit I , and at the same time supporting the fuel that may be supplied to it the grate-bars T and T^1 are employed. In some instances these grate-bars may be continuous throughout their length. In the drawings however I have shown them as made up from two sections, of which the sections T are arranged in an inclined position with respect to the horizon at the front of the fire-box, while the sections T^1 are disposed in horizontal relationship at the rear thereof. As thus arranged these sections are supported at their respective ends upon beams t and t^1 , which extend transversely of the fire-box and are secured at their opposite extremities either in the ends M of the casing, or in suitable stands t^2 , with an intermediate stand t^3 disposed beneath the middle of the inner beam t , when found necessary

or desired. While the supporting of the grate-bars T and T^1 is thus effected, the closing of the openings n and n^1 , through which the fuel is supplied to the fire-box and the ashes withdrawn from the ash-pit, is accomplished by doors n^2 and n^3 , of which the door n^2 is or may be hinged upon a horizontal axis at or near its top, while the door n^3 may be either hinged upon a vertical axis, or used without such connection, as may be preferred. As thus equipped the fire-box H receives the coal or other fuel employed for heating the boiler, which will be supplied through the opening n , when the door n^2 is opened, and deposited upon the grate-bars T and T^1 , where its combustion will be accomplished. In being thus consumed, the heated gases and other products arising therefrom will pass upward between the water-tubes E^2 to the auxiliary combustion chamber H^1 , which is located above them, and thence continue their course upward between the various series of water-tubes A and A^1 , to and around the under surface of the steam and water-drum D to the openings o in the plates O and O^1 , where they will pass to the chimney or other up-take and thence be discharged. In order however to retard the upward movement of these gases and other products of the combustion in their upward travel, whereby to insure of their more thorough commingling with the oxygen supplied to them before entering the auxiliary chamber H^1 , I make use of a deflector or baffle-plate U , which is preferably supported by the series of water-tubes E^2 , and extending from the front of the fire-box to near the rear thereof constitutes with those water-tubes an important feature of my invention. As thus arranged the gases and other products arising from the combustion, instead of passing directly upward to the auxiliary chamber H^1 , are deflected rearwardly and downwardly with respect to the boiler before being allowed to pass upward between the water-tubes E^2 , with the result that a more perfect combustion of the fuel is thereby effected, and the use of soft coal as a heating agent permitted without the objectionable escape of a large amount of it in the shape of unconsumed gases and smoke.

In the construction of the baffle-plate U various forms may be adopted. In some instances it may be made in the shape of a plate of heat resisting material of the proper length and breadth to suit it to its intended use, and, in such case, it may rest directly upon the tubes E^2 . It is preferred however to construct it in the form of sections u , which are interposed between and inclose the tubes, as shown more particularly in Fig. 2. As thus constructed and arranged these sections will preferably extend across from one end of the boiler to the other, as well as

from its front to near the rear thereof, with the result that, while the forward portion of the fire-box will be covered by them, a passage-way between the tubes E² is left at the rear for the upward travel of the heated gases and other products of the combustion to the auxiliary chamber H¹.

With the parts constructed and arranged as above set forth a cross-tube boiler is produced, in which, not only is the heating surface for the water very greatly increased, but a more perfect circulation of the water through the tubes connecting the mud-drum, and a more thorough combustion of the fuel employed in the heating operation, attained, than have been possible with boilers of this class as heretofore constructed.

Having thus described my invention and specified certain of the ways in which it is or may be carried into effect, I claim and desire to secure by Letters Patent of the United States:—

1. In a water tube boiler, in combination, a series of oppositely inclined and alternately arranged tubular sections comprising each an upper and a lower header and a series of connecting tubes, a steam and water drum above said sections, tubular connections between the upper ends of each of said lower headers and the bottom of said steam and water drum, tubular connections leading from the upper ends of each of said upper headers and running horizontally into the upper portion of said drum, baffle plates in said drum adjacent the ends of said last-named connections and arranged to deflect fluid delivered thereby to said drum toward the ends of said first-named connections, a pair of mud drums located beneath the opposite ends of said sections and communicating with each of said lower headers through tubular connections, one of said mud drums being placed at a higher elevation than the

other, and a series of connecting tubes extending across from one of said mud drums to the other and inclined to correspond with the difference in elevation thereof, substantially as described.

2. In a water tube boiler, in combination, a series of oppositely inclined and alternately arranged tubular sections comprising each an upper and a lower header and a series of connecting tubes, a steam and water drum above said sections, tubular connections between the upper ends of each of said lower headers and the bottom of said steam and water drum, tubular connections leading from the upper ends of each of said upper headers and running horizontally into the upper portion of said drum, baffle plates in said drum adjacent the ends of said last named connections and arranged to deflect fluid delivered thereby to said drum toward the ends of said first named connections, a pair of mud drums located beneath the opposite ends of said sections and communicating with each of said lower headers through tubular connections, one of said mud drums being placed at a higher elevation than the other, a series of connecting tubes extending across from one of said mud drums to the other and inclined to correspond with the difference in elevation thereof, and a deflector or baffle plate supported by and inclosing said last-named connecting tubes, said deflector extending from the front of the boiler to near the rear thereof, substantially as described.

In testimony whereof I have hereunto set my hand in the presence of two witnesses this 13th day of November, 1909.

AMASA WORTHINGTON.

Witnesses:

JOSEPH A. STARRETT,
GRACE T. DIXON.