



(19) **United States**

(12) **Patent Application Publication**
Romanovsky

(10) **Pub. No.: US 2003/0151790 A1**

(43) **Pub. Date: Aug. 14, 2003**

(54) **DISCRETE ELEMENT LIGHT
MODULATING MICROSTRUCTURE
DEVICES**

(57) **ABSTRACT**

(76) Inventor: **Alexander B. Romanovsky**, San Jose,
CA (US)

Correspondence Address:
KNOBBE MARTENS OLSON & BEAR LLP
2040 MAIN STREET
FOURTEENTH FLOOR
IRVINE, CA 92614 (US)

(21) Appl. No.: **10/247,720**

(22) Filed: **Sep. 19, 2002**

Related U.S. Application Data

(63) Continuation of application No. 10/033,153, filed on
Oct. 25, 2001, now abandoned, which is a continuation
of application No. 08/959,778, filed on Oct. 29,
1997, now Pat. No. 6,310,712.

Publication Classification

(51) **Int. Cl.⁷ G02F 1/03; G02F 1/07**
(52) **U.S. Cl. 359/245**

A light modulating or switching array (10) having a plurality of discrete protrusions (16) formed of electro-optic material, each of which is electrically and optically isolated from each other. The protrusions (16) have defined a top face (20), a bottom face (30), first and second side faces (22, 24), and front and back faces (26, 28). There are a plurality of electrodes (34) associated with each of the protrusions (16), these electrodes (34) being capable of inducing an electric field in the electro-optic material for independently modulating a plurality of light beams which are incident upon one of the faces (20, 22, 24, 26, 28, 30) of the protrusions (16). The electro-optic material may be of PLZT, or a member of any of the groups of electro-optic crystals, polycrystalline electro-optic ceramics, electro-optic semiconductors, electro-optic glasses and electro-optically active polymers. Also disclosed is a light modulating array (10) of the type having a matrix (136) of electro-optic material which contains a plurality of embedded adjacent electrodes (134). These electrodes (134) are capable of inducing an electric field in the electro-optic material for independently modulating a plurality of light beams which are incident upon the matrix (136) of electro-optic material. This matrix (136) can be formed by a variety of processes, including a sol-gel process. Additionally disclosed is a system (11) in which light modulating arrays (10) are used to modulate incident light beams (42) and separate them into a plurality of data channels (94, 96).

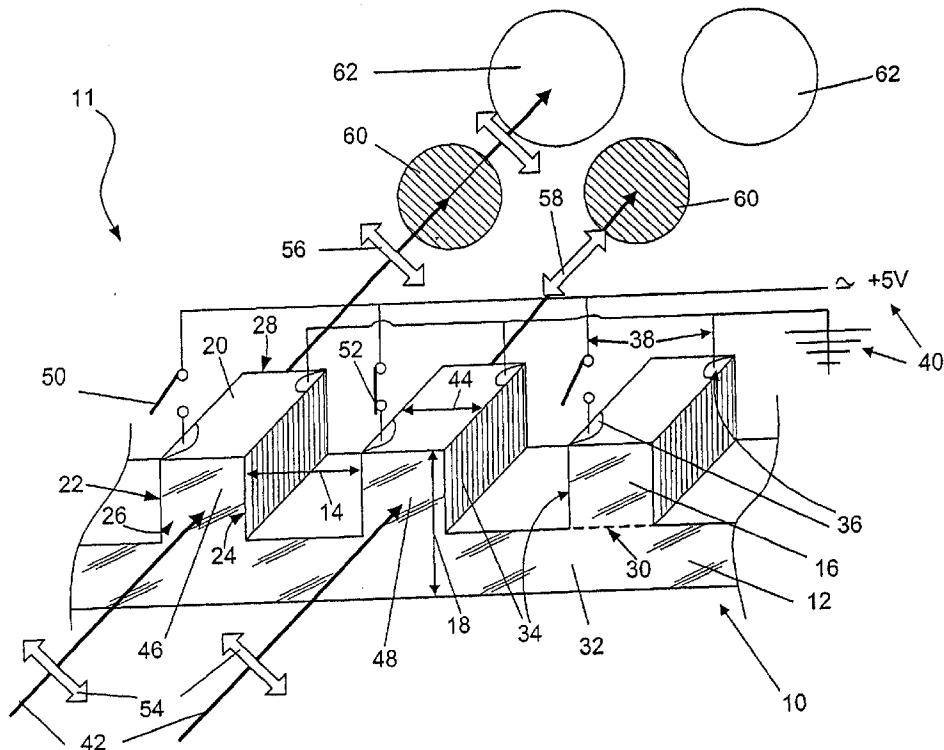

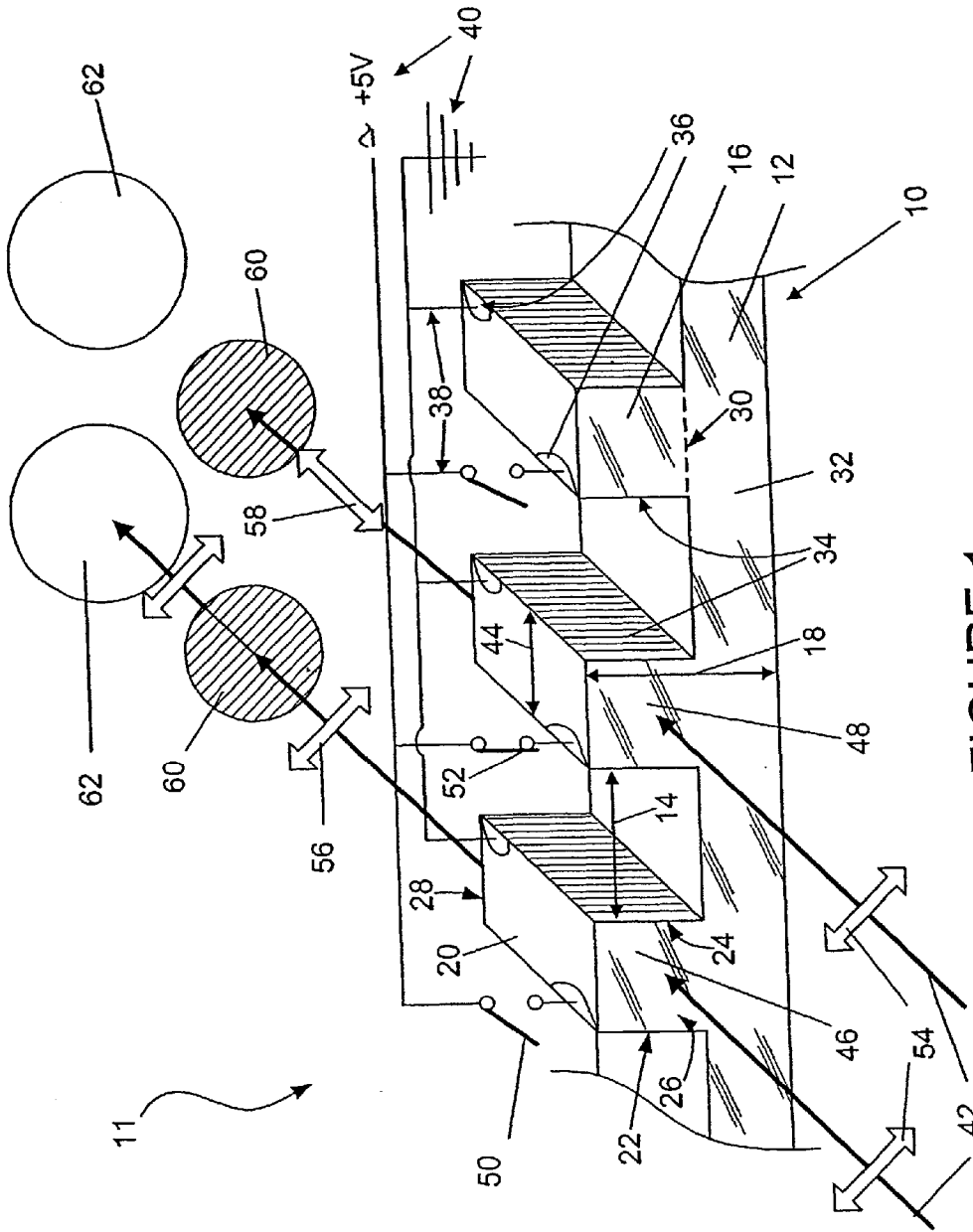

FIGURE 1

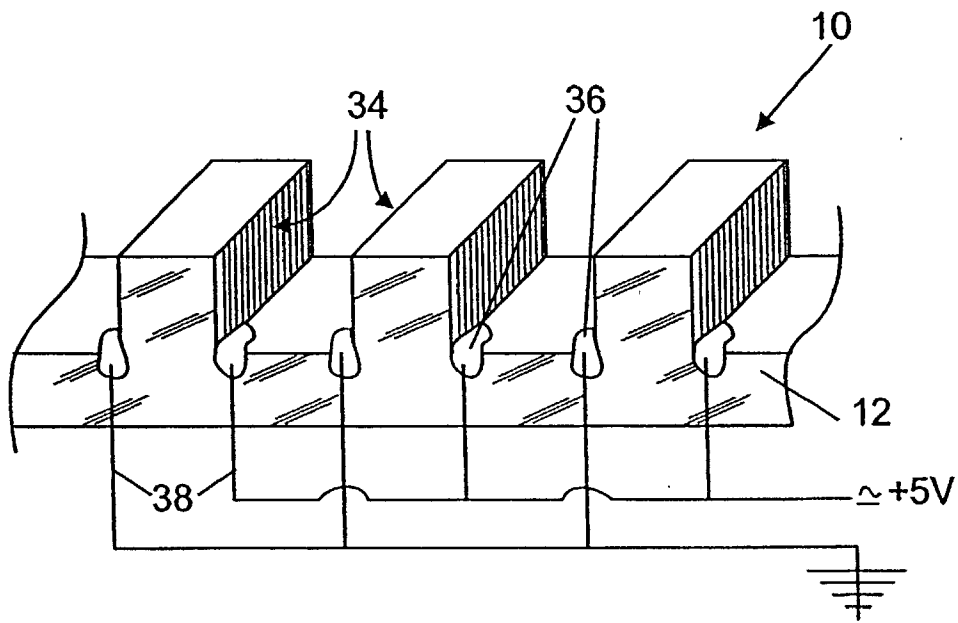

FIGURE 2

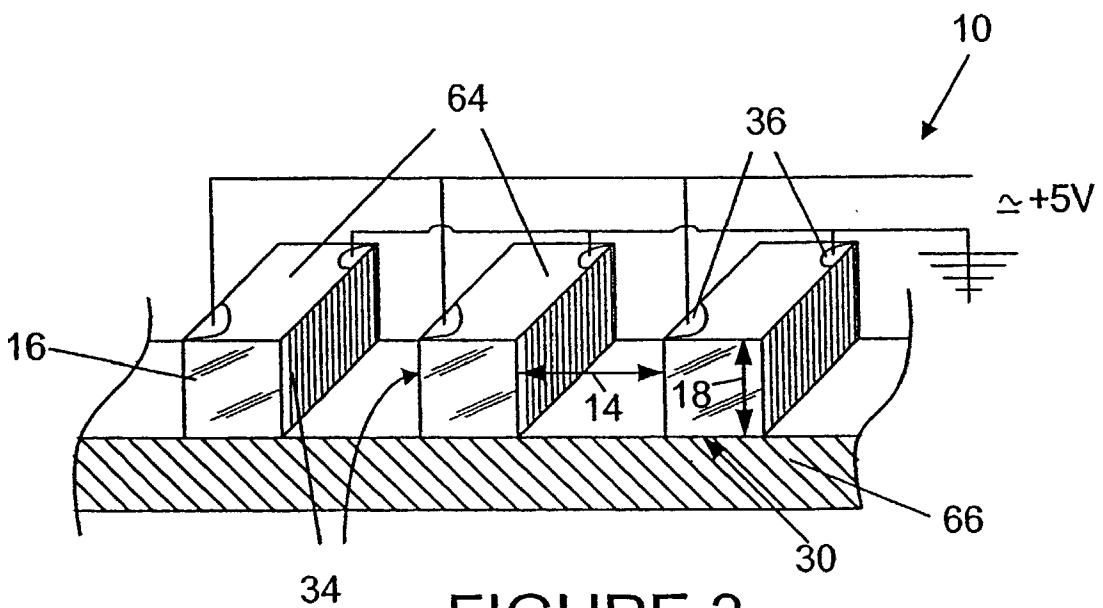

FIGURE 3

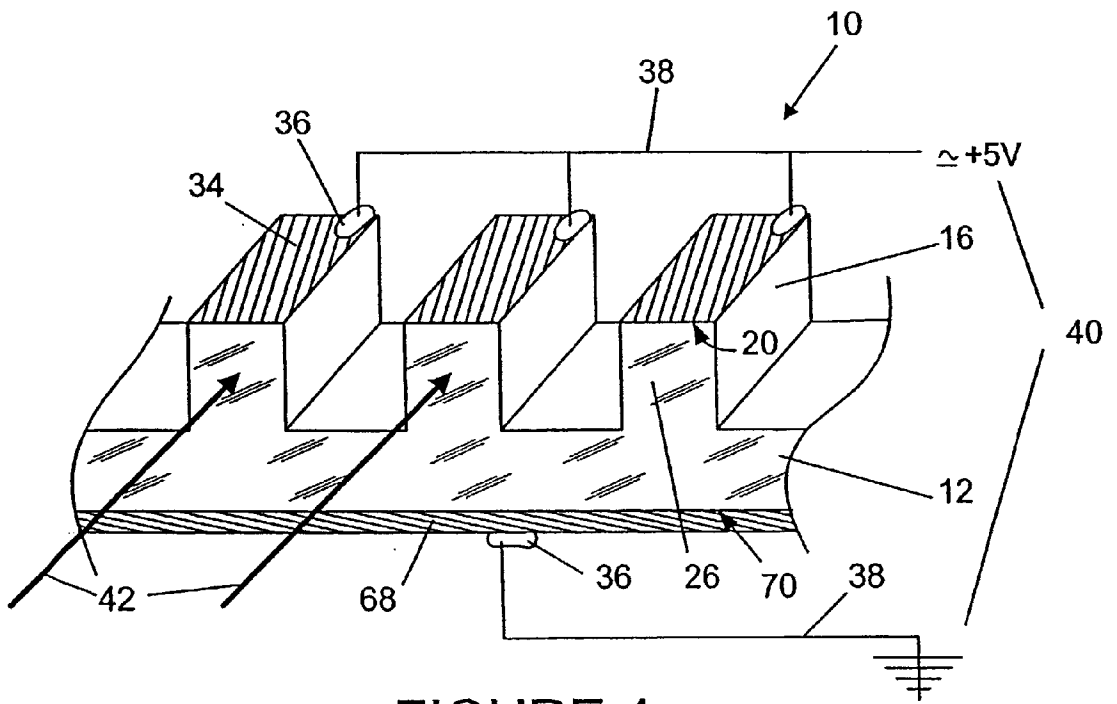

FIGURE 4

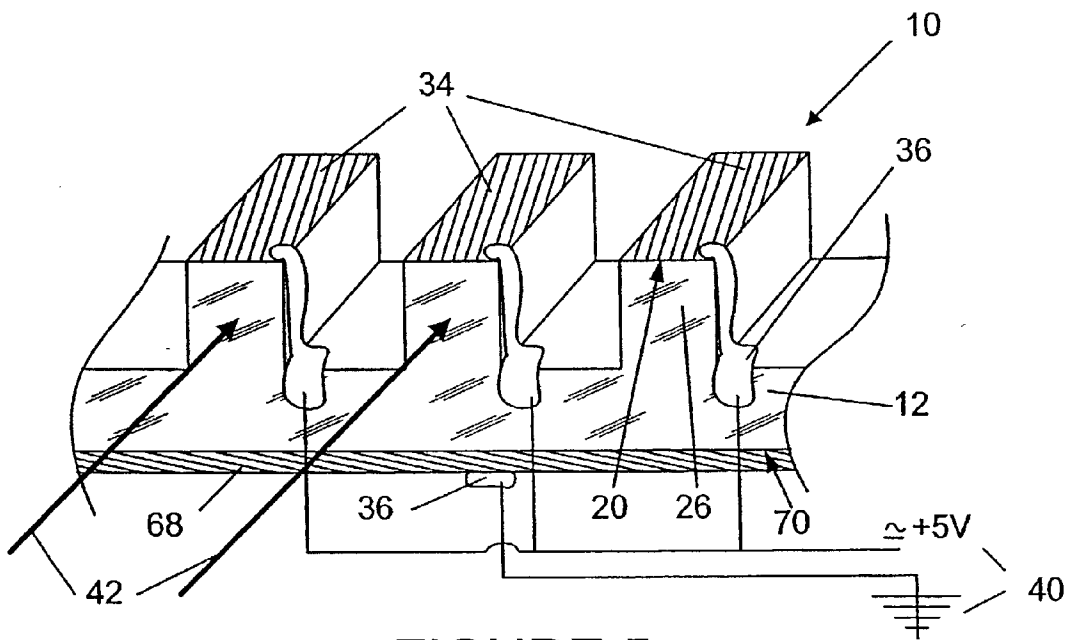

FIGURE 5

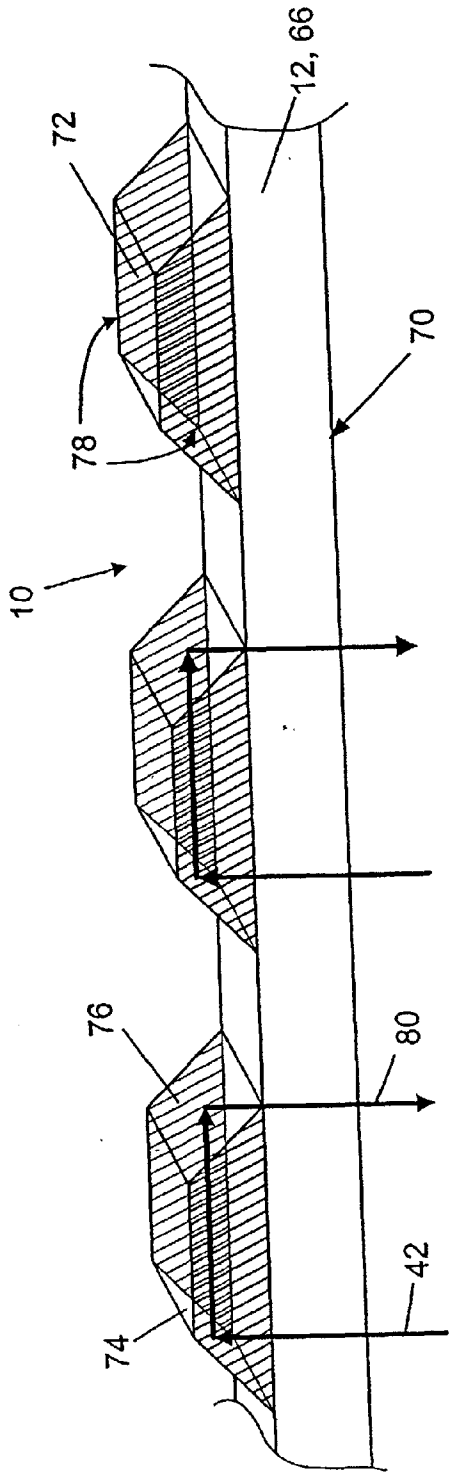

FIGURE 6

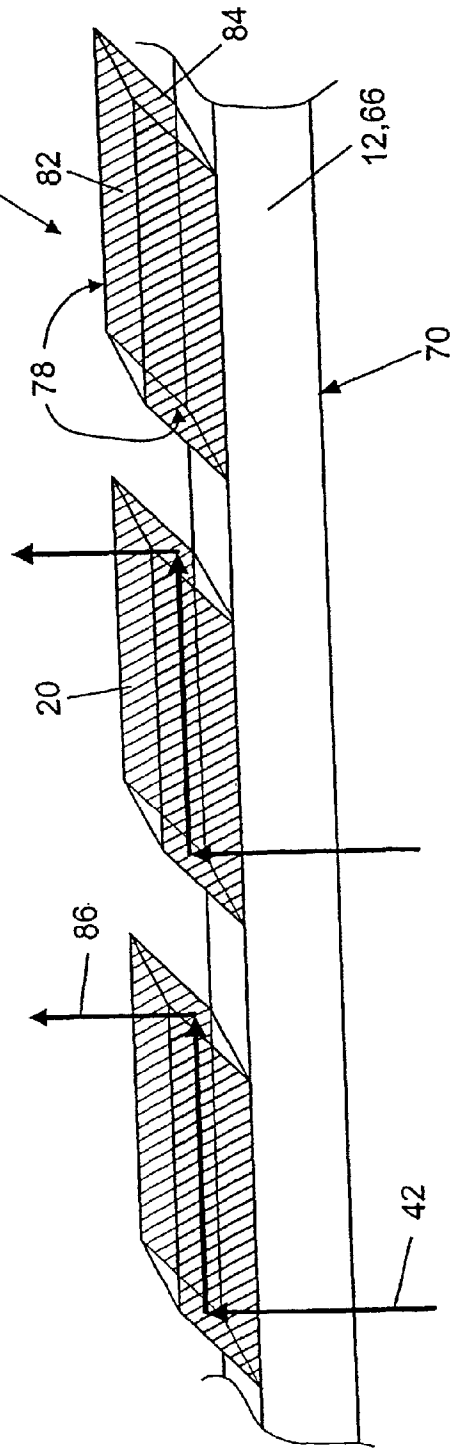

FIGURE 7

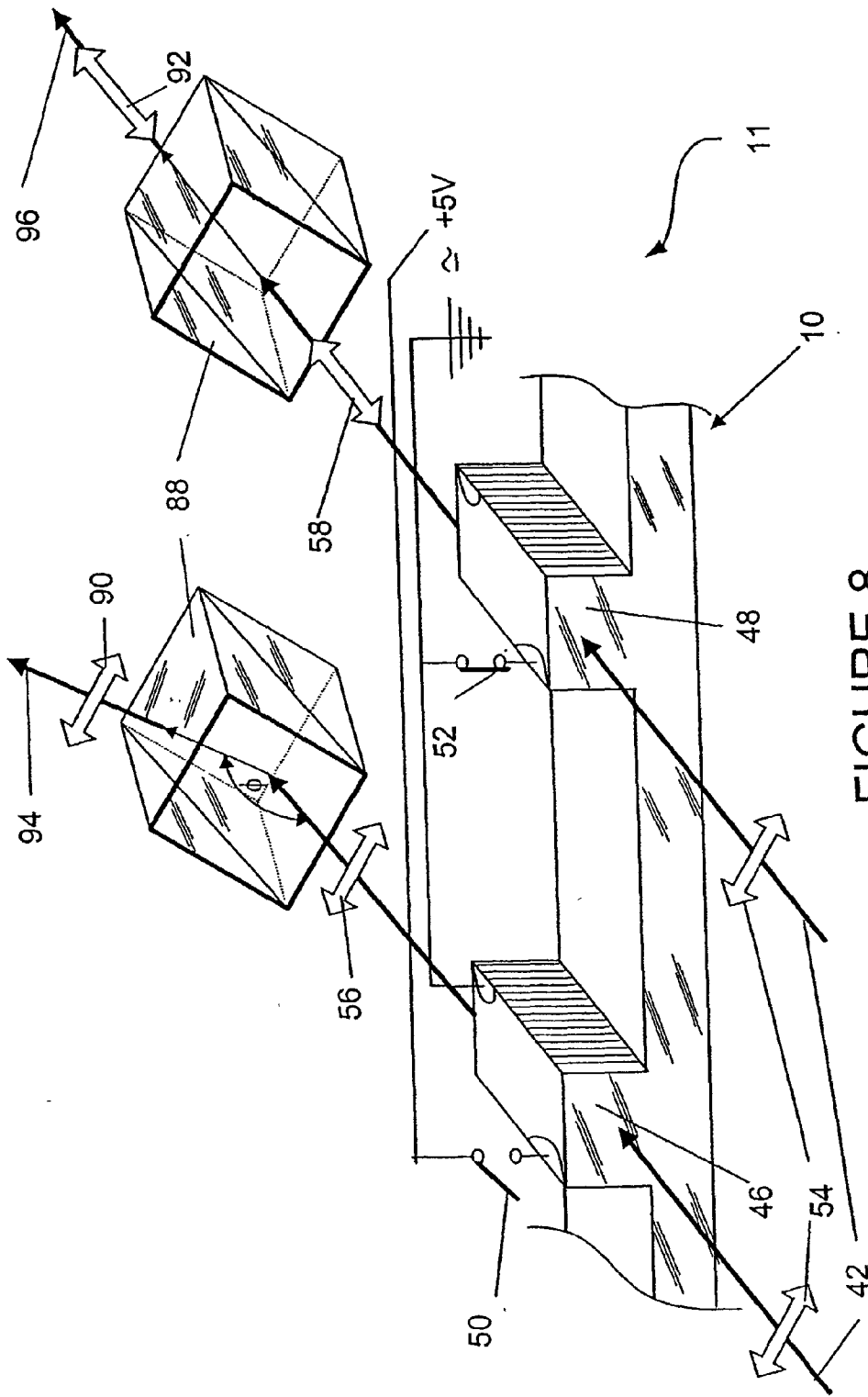

FIGURE 8

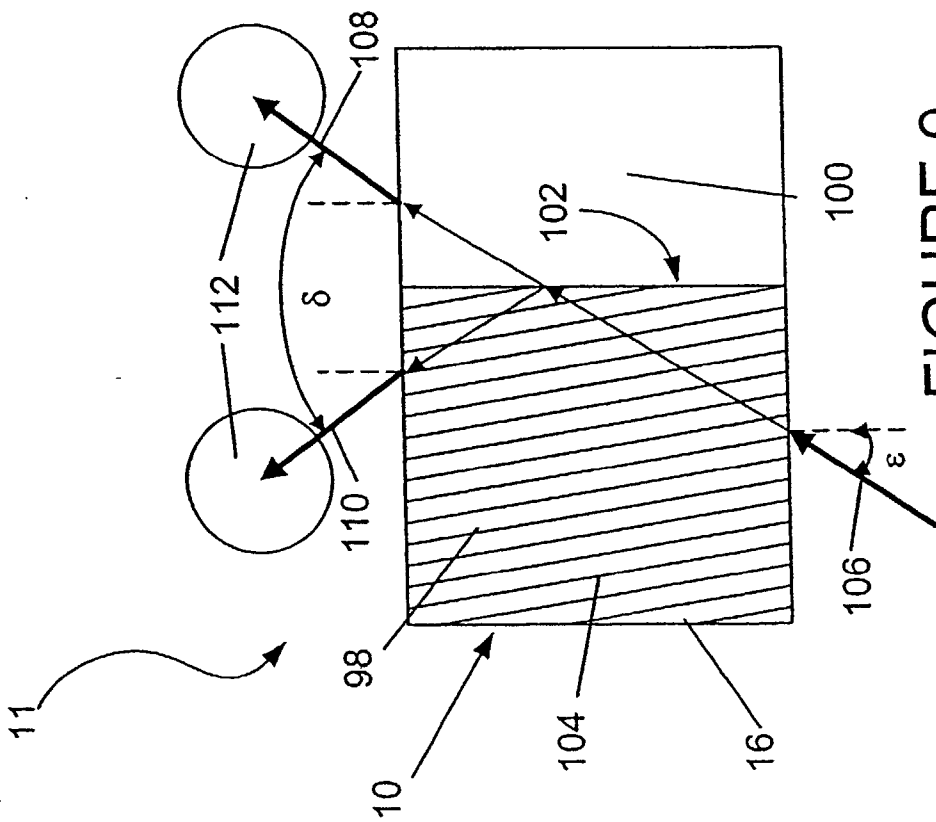

FIGURE 9

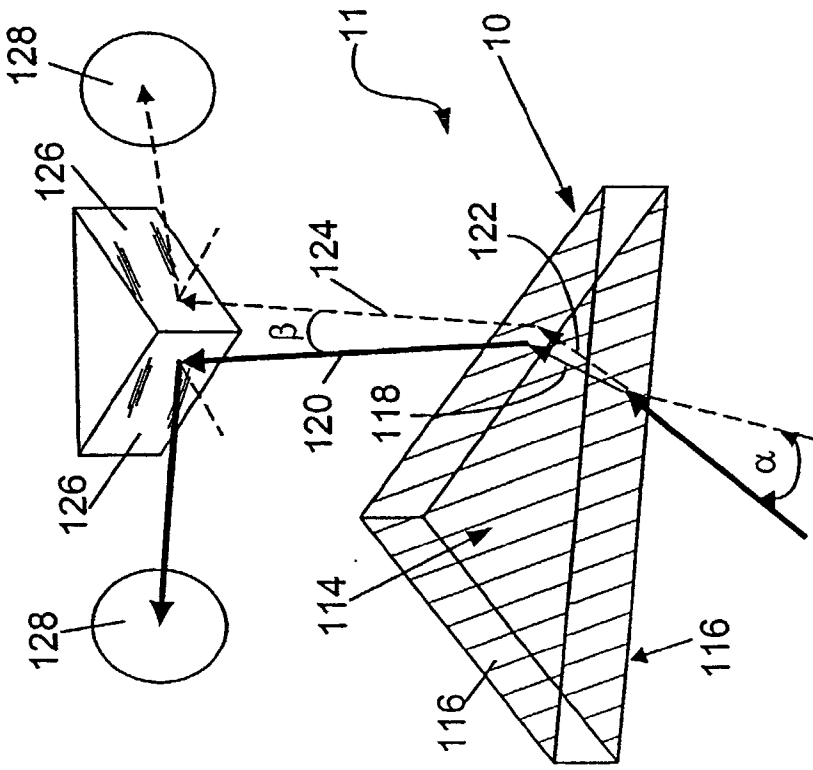

FIGURE 10

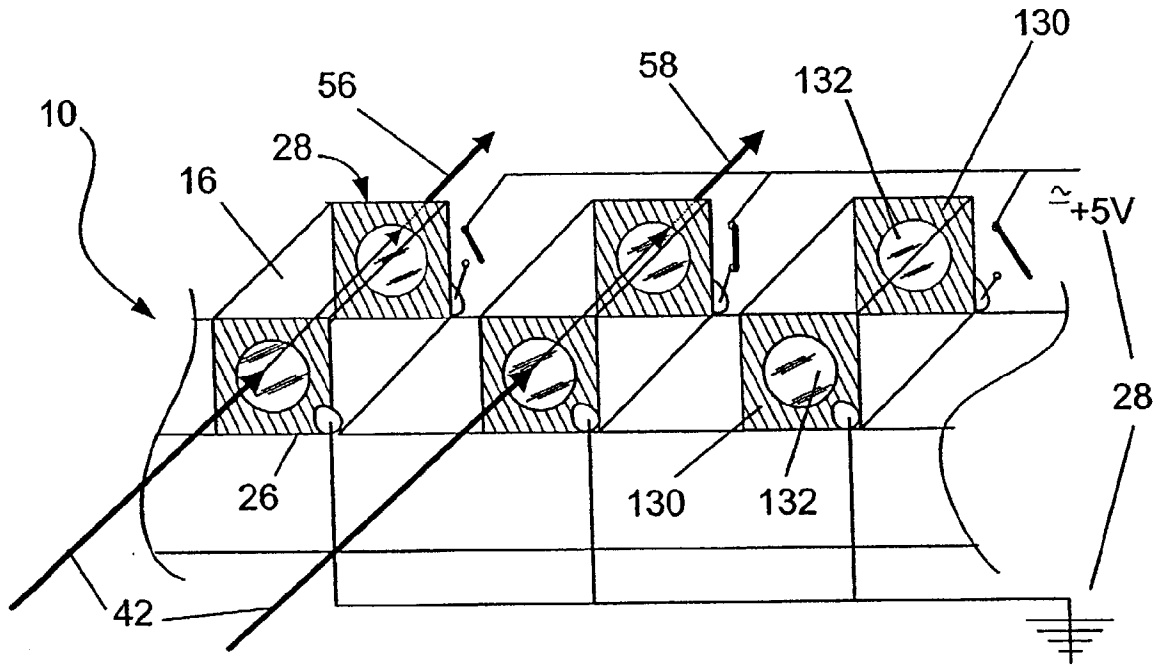

FIGURE 11

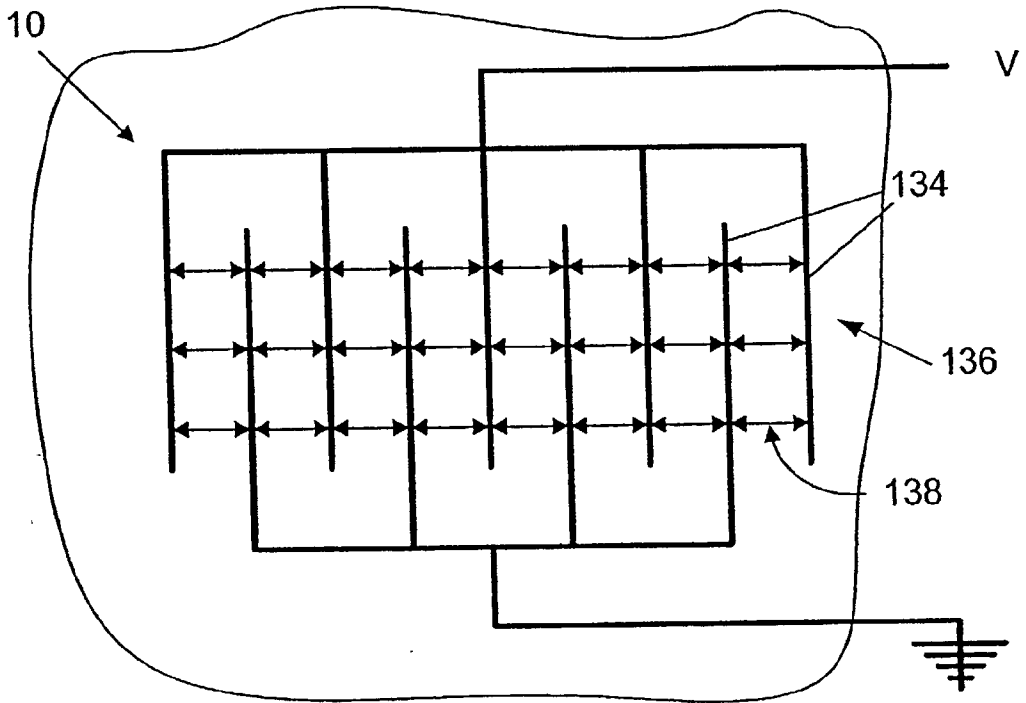

FIGURE 12

DISCRETE ELEMENT LIGHT MODULATING MICROSTRUCTURE DEVICES

TECHNICAL FIELD

[0001] The present invention relates generally to light modulators and light switches, and more particularly to electro-optic modulator arrays. The inventor anticipates that primary application of the present invention will be in high-speed printing and image processing, although it may also be used in optical interconnects, telecommunications and flat panel displays.

BACKGROUND ART

[0002] Electro-optic modulators have been well known in the art for years, but for multi-channel applications they have suffered from several disadvantages. Prior art modulator arrays have usually been formed from single wafers of electro-optically active material onto which surface electrodes have been attached, to form channels which are defined by the electric field lines within the optical wafer. Cross-talk, or interference between channels, has been a problem because electro-optic modulators are vulnerable on at least two levels. Since the channels are not restricted except by the electric field lines, activity in one channel can easily induce electro-optic interference in a nearby channel. This is in addition to usual electrical cross-talk experienced by closely grouped and unshielded electrical contacts. Also, previous electro-optic modulators and light switches have often relied on surface deposited electrodes, which produce electric field lines that are fringed, rather than channeled and directed. Due to the exponential decay of the electric field intensity inside the material, very high voltages may be required to drive the material to produce the desired electro-optic effect.

[0003] Electro-optic materials, such as LiNbO_3 , can be expensive, and can require high driving voltages. Liquid crystal modulators have also been used, but response times for this type are typically very slow, on the order of milliseconds. Also, the electro-optic effect exhibited by a material can be of several different orders, depending on the material. A first order effect, called the Pockels effect, is linear in its response to increase in applied voltage. A second order effect, called the Kerr effect, is quadratic in its response, thus a greater increase in effect can be produced relative to an increase in voltage. This can theoretically allow smaller driving voltages in a primarily Kerr effect material to be applied to produce a comparable electro-optic effect compared to material which produces primarily Pockels effect.

[0004] Lead zirconate titanate polycrystalline ceramic which is doped with lanthanum (PLZT) is a relatively inexpensive, optically transparent ceramic which can be made to exhibit either the quadratic Kerr effect or the linear Pockels effect, depending on the composition, and can be formed into wafers easily and used in sol-gel moldings. The concentrate of lanthanum, or "doping", is variable, and can lead to varying characteristics in the material. PLZT that is commercially available is typically made from a "recipe" which produces a very high dielectric constant κ . Very high κ values produce high capacitance values C , which in turn produce high power requirements, as power (P) is proportional to $CV^2/2$ where V =voltage. High power consumption

in turn generates heat, so that some modulators that require high voltage also may require cooling. If the proportion of lanthanum dopant, or other components, in the material is adjusted, the dielectric constant value and electro-optic constant value, as well as the type of electro-optic effect (Kerr or Pockels), may also be varied, with the result affecting capacitance and power consumption.

[0005] Prior art inventions for modulating light in arrays generally suffer from common problems experienced by multi-channel optical and electrical systems in which the channels are not appropriately isolated. As discussed above, interference is easily induced in nearby channels resulting in cross-talk which can distort image clarity and corrupt data transmissions. Additionally, much of the prior art requires high driving voltages that are incompatible with TTL level power supplies.

[0006] U.S. Pat. No. 4,746,942 by Moulin shows a wafer of PLZT electro-optic ceramic material with a large number of surface mounted electrodes. This invention suffers from the disadvantage of cross-talk between channels, although there is discussion of attempts to decrease cross-talk by use of large electrodes and increased space of the electro-optic windows. This results in less efficient use of the material. Although typical driving voltages are not given, with larger areas of material, higher applied voltages become necessary to provide the necessary electric field density in the wafer.

[0007] U.S. Pat. No. 4,867,543 by Bennion et al. describes a spatial light modulator made of a solid sheet layer of electro-optic material such as PLZT, which has paired surface electrodes. This has the disadvantage of requiring a driving voltage of approximately 20 volts to produce a phase retardation of π radians. U.S. Pat. No. 4,406,521 by Mir et al. discloses a panel of electro-optic material which uses electrodes to define pixel regions. It speaks of using voltages in the range of 100-200 volts. U.S. Pat. No. 5,033,814 by Brown et al. also shows a single slab of electro-optic material which requires a driving voltage of 150 volts. U.S. Pat. No. 5,528,414 to Oakley discloses a single wafer of Pockels crystal with surface mounted electrodes requiring a 70 volt driving voltage. Besides being obviously incompatible with TTL voltage levels, none of these inventions have any mechanism for confining electric field lines. Also, in general, use of higher driving voltages will generate heat in the electro-optic material, which can mean that a cooling system may be required.

[0008] U.S. Pat. No. 5,220,643 by Collings discusses an array of optical modulators which are built into a neural network. These modulators are mostly of liquid crystal type, although use of PLZT is mentioned. U.S. Pat. No. 4,560,994 by Sprague shows a single slab of electro-optic material with an array of electrodes which create fringe electric fields, which are not channeled. Sarraf's U.S. Pat. No. 5,521,748 also discloses a modulator array in which mirror-like devices deflect or deform when electrostatic force is applied. U.S. Pat. No. 4,367,946 to Varner also discusses a light valve array, with one specifically preferred material being PLZT. However, all four of these inventions can be expected to have the same problems of cross-talk, which the present invention is designed to eliminate.

[0009] For the foregoing reasons, there is a need for an array of discrete light modulating elements which can operate at TTL voltage levels, and at high speeds, with almost no

cross-talk, and which can be used to produce small pixels or which can be grouped together to create larger pixels and large two dimensional panels or sheets.

DISCLOSURE OF THE INVENTION

[0010] Accordingly, it is an object of the present invention to provide an array of discrete modulated elements of electro-optic material.

[0011] Another object of the invention is to provide arrays of electro-optically modulators that can be driven by TTL voltages, and thus be compatible with standard TTL power supplies.

[0012] Yet another object of the invention is to produce arrays of electro-optic modulators which have very little cross-talk between channels.

[0013] Still another object of the present invention is to provide an array with very fast response and switching time.

[0014] A further object of the present invention is to provide an array of pixels which can be of very small dimensions to reduce problems of aliasing in optical displays.

[0015] A yet further object of the present invention is to produce light modulating arrays that can be manufactured by conventional methods very inexpensively.

[0016] Briefly, one preferred embodiment of the present invention is a light modulating array having a number of discrete protrusions formed of electro-optic material, each of which is electrically and optically isolated from each other. The protrusions each can be viewed as having a top face, a bottom face, first and second side faces, and front and back faces. Each array also has a number of electrodes associated with each of the protrusions, the electrodes being capable of inducing an electric field in the electro-optic material for independently modulating a number of light beams which are incident upon one of the faces of the protrusions. The protrusions can be made from any number of electro-optic materials including electro-optic crystals, polycrystalline electro-optic ceramics, electro-optically active polymers, electro-optic semiconductors and electro-optic glasses. The protrusions can be integral with a substrate wafer, or formed upon a substrate of a second material. The electrodes can be attached in a variety of positions including on the sides, top and bottom, and on the front and back faces if electrodes with apertures are used.

[0017] A second preferred embodiment of the present invention is a light modulating array having a number of discrete protrusions formed of electro-optic material, each of which is electrically and optically isolated from each other, each protrusion being formed in a prism shape. Each protrusion has a top face, a bottom face, and front and rear faces. Each array also has a number of electrodes associated with each of the protrusions, the electrodes being capable of inducing an electric field in the electro-optic material for independently modulating a plurality of incident light beams. Each of the prism shaped protrusions is oriented with respect to a number of light beams such that each light beam incident upon the front face of each protrusion enters the protrusion traveling a first path and emerging at a first angle from the rear face of the protrusion when no voltage is applied to electro-optically activate the protrusion. However, each light beam travels a second path and emerges at a second angle from the rear face of the protrusion when the protrusion is electro-optically activated by application of appropriate voltage.

[0018] A third preferred embodiment of the present invention is a light modulating array having a matrix of electro-optic material, with each matrix containing a number of embedded adjacent electrodes. The electrodes are each capable of inducing an electric field in the electro-optic material for independently modulating a number of light beams which are incident upon the matrix of electro-optic material.

[0019] A fourth preferred embodiment of the present invention is a system for modulating light having a number of discrete protrusions formed of electro-optic material and a number of electrodes, as above. The system also includes a power supply capable of supplying sufficient voltage to induce a desired polarization shift from a first polarization orientation to a second polarization orientation in a beam of polarized light entering the protrusions. Also included are a switches for controlling application of voltage to the electrodes through a conductor and a separator for separating light of a first polarization orientation from light of a second polarization orientation. The separator could be any of a number of mechanisms, such as beam splitters, cross-polarizers, etc.

[0020] An advantage of the present invention is that it may be operated with TTL voltages or lower.

[0021] Another advantage of the invention is that because of the low voltage requirements, heating of the elements is reduced and requirements for cooling are minimized.

[0022] Yet another advantage of the present invention is that very small elements may be produced, thus allowing for very fine image resolution.

[0023] A further advantage of the present invention is that cross-talk between channels is nearly eliminated.

[0024] A still further advantage of the present invention is that standard micro-machining operations can be used, allowing for inexpensive manufacture.

[0025] A yet further advantage of the present invention is that sol-gel processes can be used to create arrays very inexpensively.

[0026] Yet another advantage of the present invention is that sol-gel processes can be used to make displays which are both thin and flexible. These molding processes can produce arrays with large numbers of elements quickly and for very low cost.

[0027] These and other objects and advantages of the present invention will become clear to those skilled in the art in view of the description of the best presently known mode of carrying out the invention and the industrial applicability of the preferred embodiment as described herein and as illustrated in the several figures of the drawings.

BRIEF DESCRIPTION OF THE DRAWINGS

[0028] The purposes and advantages of the present invention will be apparent from the following detailed description in conjunction with the appended drawings in which:

[0029] **FIG. 1** is a perspective view of a system for modulating and switching light beams which uses a light modulating array, showing the modulation of impinging light beams;

[0030] **FIG. 2** is a perspective view of a modulator array, and electrical circuit showing an alternative location for conductive pads;

[0031] FIG. 3 is a perspective view of a modulator array, and electrical circuit showing the elements mounted on a substrate of different material;

[0032] FIG. 4 is a perspective view of a modulator array and electrical circuit in which electrodes have been attached to the top and bottom wafer surfaces;

[0033] FIG. 5 is a perspective view of a modulator array and electrical circuit showing an alternate location for conductive pads;

[0034] FIG. 6 is a perspective view of an alternate embodiment of a modulator array and electrodes;

[0035] FIG. 7 is a perspective view of another alternative embodiment of a modulator array and electrodes;

[0036] FIG. 8 is a perspective view of system for modulating and switching light beams which uses a modulator array and beamsplitters to separate modulated and unmodulated beams into different channels;

[0037] FIG. 9 is a plan view of a system for modulating and switching light beams, which shows a single element of a modulator array used as an alternate mechanism for separating modulated and unmodulated beams into different channels;

[0038] FIG. 10 is a perspective view of a system for modulating and switching light beams which shows a single element of a different version of a modulator array used as an alternate mechanism for separating modulated and unmodulated beams into different channels;

[0039] FIG. 11 is a perspective view of a modulator array in which electrodes have been placed so as to produce an electric field which is collinear with the direction of light propagation; and

[0040] FIG. 12 is a cross-sectional view of an embedded electrode array in a sol-gel matrix of electro-optic material.

BEST MODE FOR CARRYING OUT THE INVENTION

[0041] A preferred embodiment of the present invention is an array of light modulating and switching microstructure devices. The present invention solves many of the problems of the prior art by using lanthanum doped lead zirconate titanate crystal (PLZT), which is an optically transparent ceramic that becomes birefringent when proper voltage is applied. PLZT has a quadratic electro-optic response to voltage increase thus allowing lower driving voltages. In addition, the present invention uses an optimized compositional "recipe" in which the proportion of lanthanum dopant and matrix elements has been designed to produce low dielectric constant κ ; higher electro-optic efficiency, and thus low power requirements. Additionally, the electro-optic elements are 3-dimensional and of very small size, generally $10\ \mu\text{m}$ - $200\ \mu\text{m}$ in the light propagation direction, or much less, depending on the design. This allows production of very high-density electric fields in these elements by using small voltages, including TTL levels of approximately 5 volts, and lower. This has advantages because power supplies that are already set up for TTL level digital components can supply the electro-optic modulators as well. Cross-talk has been nearly eliminated by the use of grooves or regions which are filled with air or other dielectric materials. These

physically separate at least a portion of the elements, thus directing and channeling electric field lines more closely. PLZT, as well as other electro-optic materials, also allows for pico-second response time, thus theoretically allowing very high switching frequencies of 100 GHz and more.

[0042] The use of embedded electrodes produces more uniform electric field strength in the elements. This allows a much lower driving voltage and a much more predictable and controllable electric field.

[0043] The present invention is also useful when using standard recipe electro-optic materials, in which the dielectric constant has not been minimized, and also in a variety of other electro-optic materials beside PLZT. Electro-optic materials fall generally into five categories, 1) electro-optic crystals, 2) polycrystalline electro-optic ceramics, 3) electro-optically active polymers, 4) electro-optic semiconductors, and 5) electro-optic glasses. Although the electro-optic properties of the materials are variable depending on composition, the present invention can be implemented with materials of any of these three categories. Specific examples of electro-optic materials besides PLZT which may be used include, but are not limited to, LiNbO_3 , LiTaO_3 , BSN, PBN, KTN, KDP, KD^*P , KTP, BaTiO_3 , $\text{Ba}_2\text{NaNb}_5\text{O}_{15}$, GaAs, InP, CdS, AgGaS_2 , and ZnGeP_2 . The very small dimensions of the elements result in very low element capacitance even when using material having a relatively large dielectric constant κ .

[0044] As illustrated in the various drawings herein, and particularly in the view of FIG. 1, a form of this preferred embodiment of the inventive device is depicted by the general reference character 10.

[0045] FIG. 1 illustrates an array of light modulating microstructures 10 as well as a system 11 for modulating or switching light in a number of independent channels. In this preferred embodiment, the array 10 is formed from a wafer 12 of PLZT. PLZT has been chosen for its large electro-optic effect and low absorption for thin wafers.

[0046] If PLZT is used, the relative proportion of the Lanthanum dopant in the ceramic can be very important in determining the driving voltage required for the elements. The composition also is important in establishing the optical properties such as transparency, grain size and pore size, speed, power dissipation, operating temperature and for maximizing both the linear and the quadratic electro-optic coefficients of the material. Commercial recipes for PLZT have largely used Lanthanum concentrations of 9.0% to 12%. If Lanthanum concentration is varied in the range of 8.5% to 9.0% of the PLZT ceramic and the concentration of Zirconium and Titanium are unchanged from typical ratios of 65/35, it may be possible to achieve a higher quadratic electro-optic coefficient (R) in the PLZT for the La dopant percentage closer to 8.5%. For the PLZT compositions, where Zr and Ti are maintained in a 65/35 ratio and the overall percentage of La is varied:

$$\text{La}=9.5\%, \text{R}=1.5 \times 10^{-16} \text{ m}^2/\text{V}^2;$$

$$\text{La}=9.0\%, \text{R}=3.8 \times 10^{-16} \text{ m}^2/\text{V}^2.$$

[0047] It is known that for $\text{La}<8.0\%$, PLZT loses quadratic electro-optic properties. It is therefore expected that somewhere around 8.5% La there should be a maximum for R around $(5-40) \times 10^{-16} \text{ m}^2/\text{V}^2$.

[0048] This enhanced value of electro-optic coefficient provides many advantages. It will permit lower required driving voltages, and thus lower power dissipation in the material and hence lower heating of the device. This in turn allows the device to be driven at significantly higher frequencies, even without external cooling. Also, the use of lower La concentrations (which is a free electron donor) will result in a reduced "charge screening" effect. The overall result is higher modulation efficiency of devices manufactured from this material.

[0049] The wafer 12 has regions or grooves 14 formed to produce protrusions 16 from the original thickness 18 of the wafer 12. The grooves 14 may be formed by any number of means, such as mechanical machining with micro-saws, chemical etching using photo-resist masks, or laser ablation, or the array may be molded in shape from polycrystalline ceramic, among other methods. The grooves 14 provide isolation between the channels of the array 10, serve to direct and channel the electric field lines in the electro-optic material and thus allow the array to operate with nearly zero cross-talk.

[0050] Each protrusion 16 has a top face 20, a first side face 22 and a second side face 24, a front face 26 and a rear face 28. The grooves 14 can be cut through the entire original thickness 18 of the wafer 12, in which case, the protrusions will have an independent bottom face 30, or if the groove is not cut through the entire original thickness 18, the bottom face 30 will be integral with the wafer 12, as shown by the dotted line in FIG. 1.

[0051] The faces of the wafer 32 can be polished either before or after the grooves 14 are formed, to prevent scattering of light entering or leaving the wafer 12. Electrodes 34 are attached to the protrusions 16 by any of a number of ways, but one preferred method is to embed the electrodes 34, as this may produce a more uniform electrical field. It is also possible that the material of the electrode 34 may completely fill the grooves 14. Conductive pads 36 of gold or some other metal or conductive material are used to attach electrical leads 38 to the electrodes 34, which connect them in turn to the electrical power supply 40. An electrical field is thus established which is oriented in a transverse direction relative to the direction of the incoming light beams 42. The width of electro-optic material between the grooves 14 in the protrusions 16 establishes the electrode gap 44 in this configuration of electrode 34 placement.

[0052] For ease of reference, an assembly containing a protrusion 16, attached electrodes 34, and conductive pads 36 shall be referred to as an "element". The size of the wafer 12, the protrusions 16 and the electrode gaps 44 will depend on the material chosen, and the desired range of applied voltages to be used. The electro-optic effect exhibited by an element of a particular material depends on the electric field strength within that element. The density of that field will in turn depend on the amount of applied voltage, the material chosen, and the physical dimensions of the element in which the electric field is contained. Using very small elements allows a large concentration of electric field density by use of small to moderate voltages. In the present invention, in order to use voltages in the TTL range, around 5V, it is estimated that the physical size of the elements, if made of PLZT, will be on the order of $20\ \mu\text{m} \times 20\ \mu\text{m} \times 200\ \mu\text{m}$. The grooves 14 can be made very small, and indeed may be

limited by the size of machining tools used to form them. Excellent results in terms of near zero cross-talk have been achieved using micro-sawing methods where the kerf size of the saw cuts are around $25\ \mu\text{m}$. Effective reduction of cross-talk between channels may be achieved with grooves as small as $5\ \mu\text{m}$.

[0053] Such tiny elements can produce modulated beams of very small size, producing such fine image resolution that the unaided eye is incapable of distinguishing it. It may have applications where microscopic images are required, or where multiple beams are combined in groups of 5 or 10 elements to make up 1 pixel in a display device.

[0054] The size of the elements will also depend on whether the beam is transmitted through the element or reflected from a rear surface, in which case, the length or the driving voltage can be cut roughly in half to produce the same degree of modulation. Materials with smaller electro-optic properties may require greater size or increased applied voltage to achieve proper modulation results.

[0055] In FIG. 1, a first element 46 and a second element 48 are shown, which in this preferred embodiment, will be assumed to be composed of PLZT. Between the first element 46 and the voltage supply line, an open switch 50 is shown to represent that the element 46 has no voltage applied, and is in an inactive state. It is, of course, to be understood that nothing so primitive as throw-switches need be used to practice the invention. Most likely, very high frequency (perhaps as much as 100 GHz or more) square waves of appropriate voltage will be used, but throw-switches are used here as an easy means of illustrating the state of the applied voltage.

[0056] The incoming light beams 42 having incoming linear polarization 54 which is aligned with the upper tip 45 degrees to the left of vertical, (which shall be referred to as "R" polarization) impinge on both elements 46 and 48. This incoming light may be linearly polarized laser light, or it may be initially unpolarized light, perhaps even including light from an incandescent bulb, which has been transmitted through a polarizer to produce linearly polarized light. First element 46 is inactive, thus the outgoing polarization 56 of the first element 46 is unchanged. It passes through an R aligned polarizer 60 and is detected by a light sensor or photo detector 62, perhaps to be recognized as a digital "1".

[0057] In contrast, switch 52 is closed leading to the second element 48, thus the supply voltage is applied and the element 48 is active. The element 48 becomes birefringent under the influence of the applied electric field. Birefringence causes an incoming beam 42 which is linearly polarized at a 45 degree angle relative to the direction of the applied electric field to split into two orthogonal components which are respectively parallel and perpendicular to the electric field lines. These components travel along the same path but at different velocities. The electro-optic effect thus will cause a phase shift between the two components, as one is retarded in relation to the other. After traveling through the element 48, the components re-combine with the result that the polarization of the emergent beam 58 is changed. If the voltage is sufficient to cause a $\lambda/2$ shift in polarization, the polarization will be rotated by 90 degrees, relative to its original orientation. In FIG. 1, it is assumed that a $\lambda/2$ voltage of 5 volts has been applied which produces a 90 degree phase shift to give a linearly polarized output beam

58, which is oriented with the upper tip now 45 degrees to the right of vertical (which shall be referred to as “S” polarization). This S polarized light is now blocked by the R aligned polarizer **60**, which allows no light to reach the detector **62**. This may be recognized by a digital device as a “0”.

[**0058**] If the applied voltage causes a $\lambda/4$ rotation, the outgoing polarization **58** will be made into circular polarization, as the tip of the resultant electric field vector will describe a circle as it propagates. Intermediate voltage values will result in elliptical polarization. These will be incompletely blocked by the polarizer **60**, which will allow only the R aligned component to pass. Thus, the light seen by the detector **62** may be theoretically controlled anywhere in the range from undiminished incoming intensity to total extinction, to produce analog-type output signals if the appropriate control voltage is applied.

[**0059**] **FIG. 2** illustrates a different version of the modulator array **10**. A wafer **12** is shown with attached or embedded electrodes **34**, and in this embodiment, the conductive pads **36** are located in a different configuration for attachment to electrical leads **38**.

[**0060**] **FIG. 3** illustrates another version of the modulator array **10**, in which the grooves **14** have been extended completely through the original thickness **18** of the wafer. The elements **64** here are composed of the protrusion **16** portions of the wafer **12** and their respective attached or embedded electrodes **22** and conductive pads **24** (see **FIG. 1**). A number of elements **64** have been formed on a substrate **66** made from a different material which the bottom faces **30** now contact. This substrate **66** is preferably a low dielectric material that is not electro-optically active, such as SiO_2 , for one example among many. The protrusions **16** may be attached or glued to the substrate **66** prior to machining or attachment of the electrodes **34** and pads **36**, or the completed elements **64** may be assembled prior to attachment to the substrate **66**.

[**0061**] **FIG. 4** shows yet another version of the modulator array **10**. In this embodiment, electrodes **34** are attached to the top faces **20** of the protrusions **16** and a single large electrode **68** is positioned on the bottom side **70** of the wafer **12**. It is to be understood that a plurality of appropriately placed individual electrodes could be used on the bottom side **70** of the wafer **12** in place of the single large electrode **68** pictured here and in the following **FIG. 5**. Conducting pads **36** are attached to the top and bottom electrodes **34**, **68** as attachment points for the electrical leads **38**. Polished front faces **26** are indicated as before, and incoming light beams **42** are shown to indicate orientation. The polarization direction has not been shown, as the principles of phase retardation operate much the same as in **FIG. 1**, with a $\lambda/2$ shift producing a 90 degree rotation, etc. This placement of electrodes **34**, **68** produces a different orientation of transverse electrical fields, but still retains the advantage of channel separation and minimization of cross-talk which was unavailable in the prior art.

[**0062**] **FIG. 5** shows a variation of the configuration in **FIG. 4**, in which the upper conductive pads **36** are located in a different orientation relative to the wafer **12**. The top and bottom electrodes **34**, **68** are positioned as in **FIG. 4**, to produce a transverse electric field. The polished front faces **26** and incoming light beams **42** are again shown for orientation purposes.

[**0063**] Although not pictured here, it is to be understood that this arrangement of top and bottom electrodes and the variations in conductive pad locations seen in **FIGS. 4 and 5** can be used with elements which have been positioned on a different substrate material, in the manner suggested by **FIG. 3**, if the substrate material has the proper conductive properties. It may also be possible for elements to be directly attached to a single large bottom electrode which can act as a substrate to support and position the elements. Alternately, the electrodes may be attached or embedded on both sides of the electro-optic material directly before mounting the assembled elements onto a substrate.

[**0064**] **FIG. 6** shows another version of an array **10** of modified protrusions **72** which have either been formed on the original wafer **12** or formed separately on a substrate of different optically transparent material **66** in a similar manner to the embodiment shown in **FIG. 3**. The modified protrusions **72** are shown to be oriented with their long sides parallel to the long edge of the wafer **12** or substrate **66**, but it should be understood that they may also be oriented with the long sides of the protrusions **72** transverse to the long edge of the wafer **12** or substrate **66**. An incoming polarized light beam **42** enters from the bottom side **70** of the wafer **12** or substrate **66** and is internally reflected on the angled first side face **74** and angled second side face **76** to reemerge from the bottom side **70** of the wafer **12**. If appropriate voltage has been applied to the electrodes **78**, the resulting polarization of the emergent light beam **80** will be modulated in the manner described above. The angles of the faces here are chosen to allow total internal reflection, but it is to be understood that if a reflective coating is applied to the faces, a variety of other angles may be used as well.

[**0065**] **FIG. 7** illustrates yet another version of a modulator array **10** in which the protrusions **82** have been modified in another manner such that the angled second side face **84** of each has been angled to direct the emergent beam **86** out of the top face **20** of each protrusion **82**. As in **FIG. 6**, the protrusions may be oriented in a transverse direction, a different substrate material may be used, and a reflective coating may be applied to reflecting faces.

[**0066**] **FIG. 8** shows a system **11** for modulating or switching light beams which uses the modulator array **10** in much the same configuration as in **FIG. 1**. An incoming linearly polarized beam **42** of polarization “R” enters a first element **46** which is inactive due to an open switch **50**, so that its exiting polarization **56** is unchanged. This enters a beamsplitter **88** that has been positioned so that light of R polarization will be reflected out of the beamsplitter at angle ϕ , as shown by reflected beam **90**. In a second element **48**, which is active, the voltage is assumed to be such as to produce a $\lambda/2$ shift, the polarization is rotated 90 degrees to “S” orientation, and this passes through the beamsplitter **88**, as shown by unreflected beam **92**. These beams can be used to carry separate digital information, and may be designated “channel 1”**94** and “channel 2”**96**. It is to be understood that beamsplitters can be used as a channel separation device with any of the various embodiments illustrated herein.

[**0067**] **FIG. 9** shows a top plan view of another system **11** for modulating or switching light beams which uses a different version of a light modulating array **10**. A single protrusion **16** is shown, which is composed of a first block **98** or portion of material having an index of refraction N_1 ,

and a second block **100** of material having index of refraction N_2 . A boundary **102** is formed at the junction of the two materials. One of the two blocks, in this case the first block **98**, has top and bottom electrodes **104**. First block **98** is composed of electro-optic material such that when electrodes **104** are uncharged, the electro-optic material is inactive, and $N_1=N_2$. When voltage is applied to electrodes **104**, the first block **98** becomes active and the index of refraction changes for polarization components which are aligned with the electric field lines so that for this polarization, $N_1>N_2$. When first block **98** is inactive, an incoming beam **106** is projected into the first block **98** at entry angle ϵ to a normal such that the beam passes through the boundary between the two blocks **98**, **100** and emerges as unreflected light ray **108**. When first block **98** is active the index of refraction is increased such that total internal reflectance (TIR) occurs, and the beam is reflected back into the first block **98** at the boundary **102**, and emerges as reflected light ray **110**. The two emergent beams **108** and **110** are separated by angle δ , which has been greatly exaggerated here. These separated beams **108**, **110**, can be detected by sensors **112**, and thus be used to establish channel separation for data transmission.

[0068] Alternatively, the protrusion **16** can be made from a single integral block of material, which has been electro-optically divided into portions or sections. A first section **98** may have electrodes **104** attached to induce a different index of refraction in this section. An incoming beam **106** will then be totally internally reflected, as described above, at the interface between the activated **98** and unactivated sections **100**. This interface or boundary **102** can be established more definitely by having the second section **100**, be of a different thickness than the first **98**. This serves to direct the electric field lines better so that less fringing is produced, and a sharper interface boundary **102** is established.

[0069] FIG. 10 shows a perspective view of another system **11** for modulating or switching light beams which uses yet another version of the light modulating array **10** to perform channel separation. A single prism-shaped protrusion **114** is shown, which can be electro-optically activated by electrodes **116** to increase the index of refraction. This causes the light beam to be bent towards the normal upon entry slightly differently than when the material is an inactive state. Thus when the element is active, the light beam will follow a first path **118**, and will emerge at a slightly different angle relative to the normal upon leaving the element, thus following a first exiting path **120**. In contrast, when the element is inactive, the light follows a second path **122** upon entry, and follows a second exiting path **124**. Both of these second paths are shown in dashed line in FIG. 10. These first and second exiting paths **120**, **124** are separated by angle β , and they can be further directed by mirrored surfaces **126** to sensors **128** to produce separate channels. The separation of the paths and the separation angle has been exaggerated in the FIG. 10.

[0070] FIG. 11 illustrates yet another version of the present light modulating array **10** in which end-mounted electrodes **130** each having an aperture **132** have been attached to the front faces **26** and rear faces **28** of the protrusions **16**. In this configuration, the electric field lines are collinear with the direction of incoming light beams **42**. The application of appropriate applied voltage results in the change in polarized output in a manner similar to that discussed above. It is to be understood that the above

mentioned methods of splitting the output into separate channels, or using an external polarizer and sensor may be used, as well as mounting of elements on different substrate material, and variations in conductive pad placement.

[0071] It is also possible to have a light-producing element, such as a diode laser, with a modulating element physically attached at the laser's output, in order to produce a single integrated element.

[0072] Another variation of the preferred embodiment uses sol-gel processing to create an array of elements that are fixed in a flexible medium. Sol-gel processing is a chemically based, relatively low temperature (400-800 degrees C.) method that can produce ceramics and glasses with better purity and homogeneity than higher temperature (2,000 degrees C.) conventional processes.

[0073] When using molding processes, two approaches are possible. In the first approach, a non electro-optic, optically transparent or non-transparent matrix is prepared. Electrodes are deposited on the side walls. Then it is filled with soft, curable electro-optic material of sol-gel type or polymer resin. It is then cured to produce an array of electro-optic modulators separated spatially by non electro-optic material.

[0074] In the second approach, an electro-optically active matrix of solid or flexible material is prepared. Electrodes are deposited on the side walls. Then it is filled with soft, curable non electro-optic material, of optically transparent or non transparent, sol gel type or polymer resin. Then it is cured to produce an array of electro-optic modulators separated spatially by non electro-optic material.

[0075] For the PLZT thin films made by the sol-gel process with 1-2 μm spacing between embedded adjacent electrodes, $\lambda/2$ voltages range from 20-30 Volts for 0.5 μm thick films, to TTL levels (4-5 Volts) for 1-2 μm film thickness. This idea is very attractive for large area flat panel display applications, which function like CRT tubes and which may successfully compete with them. Because electrode spacing is necessarily very small to achieve low driving voltages, resulting pixel size is also very small, which makes this embodiment ideal for high-resolution flat panel displays or spatial light modulators. This fine pixel structure is below typical resolution capability of the human eye, so for consumer applications, sub-micron and micron size substructures may be aggregated to produce standard sized pixels (usually dozens or hundreds of microns). To simplify the manufacturing process and make it compatible with existing flat panel technology, the pixel size can be made larger. In this case, each pixel represents an interdigital pattern of PLZT embedded shutter electrodes.

[0076] FIG. 12 shows a top plan view of a modulator array **10** composed of embedded electrodes **134** that are contained in a sol-gel matrix **136**. The arrow lines indicate electric field lines **138**. The height of the electrodes **134** (out of drawing plane) is defined by the thickness of the film. In the figure, light also travels perpendicular to the drawing plane. For non-polarized light, the modulator array **10** is placed in between two cross polarizers (not shown).

[0077] The electrode structures can be deposited either prior to the sol-gel film deposition, or after it, using standard etching or micro-machining techniques. Using etching techniques and molding processes, the height of the electrodes

134 can be much higher, 10 μm or more with the same 1-2 μm spacing between electrodes. In this case, sol-gel can fill the spacings between electrodes **134** and the thin film can still be thin enough (a few microns) to guarantee the same fabrication process and similar process conditions. This will allow driving or switching voltages on the TTL level (4-5 Volts) or below (1-3 Volts and even lower). The arrays thus fabricated can be used in either transmissive or reflective modes. Additionally, the sol-gel material can either be used to completely fill the gap between electrodes, or it can instead be deposited on the sides of the electrodes as a coating. If used as a coating, an additional electrode can be added on the outer side of the sol-gel coating to make a complete element, each element being separated from its neighbor by a gap or groove.

[**0078**] In addition to the above mentioned examples, various other modifications and alterations of the inventive device **10** may be made without departing from the invention. Accordingly, the above disclosure is not to be considered as limiting and the appended claims are to be interpreted as encompassing the true spirit and the entire scope of the invention.

INDUSTRIAL APPLICABILITY

[**0079**] The present device **10** is well suited for application in a wide range of fields in which light modulators and high speed light switching devices are used, such as in high-speed printing, image processing and telecommunications. The present invention **10** is also especially suited for use in flat panel displays and projection television.

[**0080**] Although the basic array structures **10** discussed above are in a one-dimensional line configuration, these may be configured and arranged to form two-dimensional sheets of large size. Additionally, by use of the sol-gel process, they may be used to make a kind of thin flexible display material almost like cloth, which may be used to cover three dimensional forms or perhaps even to make clothing.

[**0081**] The materials presently used in flat panel displays respond very slowly to changes in display information. This leads to the commonly observed problem, especially in flat panel displays of laptop computers, that the display of a moving object will leave trails behind, due to the lag in the response of the display. The present invention, by contrast, is capable of switching speeds of 100 GHz and more, producing such fast response that it is beyond the ability of the human eye to register individual steps in a display of motion.

[**0082**] Prior art displays also may exhibit the problem of aliasing, or the jagged edges sometimes seen around the outline of a displayed object due to the comparatively large size of pixels in a digital display. By contrast, the elements of the present invention **10** may be made as smaller than 1 $\mu\text{m} \times 1 \mu\text{m}$ in cross section, each element being capable of producing an independent signal. Thus each element is potentially an independent pixel. The use of the present invention completely eliminates the problem of aliasing down to the microscopic scale. Indeed, the human eye cannot resolve such small elements. Thus for use on the scale of ordinary unaided human vision, the elements may be grouped into larger pixels, whose overall size can still be small enough to provide far better image resolution than is presently available. There may also be applications in which

microscopic pixel size is advantageous, such as making microscopic photo masks for microchip manufacture. The ungrouped pixels of the present invention are uniquely suited for such uses.

[**0083**] The very small size of the elements allows low driving voltages to be used to produce the necessary electric field density to induce the desired electro-optic effect. TTL levels may be used with some materials. The use of TTL level voltages has many significant advantages. TTL level power supplies have been well developed over many years and are commonly available "off the shelf". Thus power supplies can be easily obtained for systems that utilize the present invention **10**, without having to provide a customized power supply. This also allows easier introduction of the present invention **10** into equipment that uses TTL devices and already has the appropriate power supply in place.

[**0084**] The present invention **10** also may be designed to utilize sub-TTL levels. It is useful in many applications in which these smaller driver voltages are supplied.

[**0085**] Prior art light modulators and optical switches that are fabricated on a common wafer without benefit of any feature to channel the electric field lines commonly suffer from problems with cross-talk between the channels. This interferes with image clarity and can corrupt transmitted data. By contrast, by utilizing the discrete elements of the present invention **10**, cross-talk between channels is practically eliminated, resulting in cleaner image production and improved accuracy and integrity of data transmission. This has very many industrial applications in a wide variety of devices such as printers, telecommunications, and visual displays.

[**0086**] In addition, for telecommunications applications, prior art diode lasers which have been used, have typically suffered from the problem of "chirping" which is interference which can be produced when the voltage supplied to a diode laser is rapidly modulated. In contrast, the present invention **10** modulates the optical output rather than the diode laser itself. This greatly reduces interference and can eliminate the problem of chirping. This can be an important advantage for telecommunications applications.

[**0087**] Another feature that makes the present invention **10** especially desirable for industrial applications is its ease of manufacture and low cost. It can be made using existing technology by varying methods such as micro-machining, laser ablation, selective etching in an electric field, and molding by conventional means or using a sol-gel process. For micro-machining, the same kinds of micro-saws as are presently used in trimming silicon wafers can be used to form the slots between the projections.

[**0088**] Another method for manufacturing light modulating arrays **10** is the use of sol-gel processing to create an array of elements that are fixed in a flexible medium. Sol-gel processing is a chemically based, relatively low temperature method that can produce ceramics and glasses with better purity and homogeneity than higher temperature conventional processes. Another of the attractive features of the sol-gel process is the capability to produce compositions not possible with conventional methods.

[**0089**] Thin films of PLZT electro-optic ceramic made with the sol-gel process have a number of advantages

relative to PLZT ceramics prepared from powders. Large surface areas of thin film can be created which have very uniform (homogeneous) material structure. Small grain sizes are achievable, in the range of 10's of nm, with much less porosity compared with PLZT ceramics prepared from powders. A wide range of film thickness from a few nanometers to a few microns can be produced.

[0090] Sol-gel manufacture also easily lends itself to high volume production. It is inexpensive, suitable for large area spatial light modulators or flat panel displays and can utilize micro-machining fabrication processes which are standard in the industry. It can be used for bright, ultra high-speed flat panel displays or spatial light modulators suitable for computer interconnects and high-speed telecommunications with very wide viewing angles which may eventually be used to replace cathode ray tubes.

[0091] For the above, and other reasons, it is expected that the device **10** of the present invention will have widespread industrial applicability. Therefore, it is expected that the commercial utility of the present invention will be extensive and long lasting.

What is claimed is:

1. A light modulating array comprising:

a plurality of discrete protrusions formed of electro-optic material, each discrete protrusion being electrically and optically isolated from each other, said protrusions further having defined a top face, a bottom face, first and second side faces, and front and back faces; and

a plurality of electrodes associated with each of said protrusions, said electrodes being capable of inducing an electric field in said electro-optic material for independently modulating one or more light beams which are incident upon one of said faces of said protrusions.

2. The light modulating array of claim 1 wherein:

said protrusions are formed from a single wafer of electro-optic material and said bottom faces of said protrusions are integral with said wafer.

3. The light modulating array of claim 1 wherein:

said protrusions are formed on a separate substrate layer.

4. The light modulating array of claim 1 wherein:

said protrusions are separated by regions of dielectric material.

5. The light modulating array of claim 1 wherein:

each of said first side faces are angled such that incident light beams are internally reflected within said protrusions.

6. The light modulating array of claim 5 wherein:

said second side face is angled such that incident light beams are directed to exit said protrusions.

7. The light modulating array of claim 6 wherein:

said first and second angled faces include a reflective means.

8. The light modulating array of claim 1 wherein:

said electro-optic material is selected from the group consisting of electro-optic crystals, polycrystalline electro-optic ceramics, electro-optically active polymers, electro-optic semiconductors and electro-optic glasses.

9. The light modulating array of claim 8 wherein:

said electro-optic material is PLZT where the lanthanum concentration lies in the range of 8.5% to 9.0% of the overall composition.

10. The light modulating array of claim 1 wherein:

said electrodes are attached to said first and second side faces of said protrusions.

11. The light modulating array of claim 1 wherein:

said electrodes are attached to said front and rear faces of said protrusions and said electrodes include an aperture for passage of light beams.

12. The light modulating array of claim 2 wherein:

said wafer includes a bottom surface; and

an electrode is attached to each top face of each of said protrusions and one or more electrodes contact said bottom surface of said wafer.

13. The light modulating array of claim 3 wherein:

an electrode is attached to each said top face of each said protrusion and said substrate layer includes one or more electrodes which contact said bottom face of each of the protrusions in the array.

14. The light modulating array of claim 1 wherein:

each of said protrusions includes a first portion of said electro-optic material to which a plurality of electrodes is associated, and each of said protrusions further includes a second portion composed of material with an index of refraction matching that of said first portion when no voltage is applied to electro-optically activate said first portion, but said index of refraction of said second portion is less than the index of refraction of said first portion when said first portion is electro-optically activated by application of appropriate voltage;

said first and second portions are in close conjunction with each other such that a boundary is formed at the junction of said first and second portions; and

each of said protrusions is oriented with respect to one or more light beams such that said each of the light beams enters each first portion of each protrusion and strikes said boundary between said first and said second portions at an angle such that each light beam is totally reflected internally when said first portion is electro-optically activated by application of sufficient voltage, but which will pass unreflected through said boundary when said first portion is not electro-optically activated.

15. A light modulating array comprising:

a plurality of discrete protrusions formed of electro-optic material, each discrete protrusion being electrically and optically isolated from each other, said protrusions further being formed in a prism shape having defined a top face, a bottom face, and front and rear faces;

a plurality of electrodes associated with each of said protrusions, said electrodes being capable of inducing an electric field in said electro-optic material for independently modulating one or more incident light beams; and

each of said prism shaped protrusions is oriented with respect to one or more light beams such that each light

beam incident upon said front face of said protrusion enters each protrusion traveling a first path and emerging at a first angle from said rear face of said protrusion when no voltage is applied to electro-optically activate said protrusion, but each light beam travels a second path and emerges at a second angle from said rear face of said protrusion when said protrusion is electro-optically activated by application of appropriate voltage.

16. A light modulating array comprising:

a matrix of electro-optic material; and

said matrix containing a plurality of embedded adjacent electrodes, said electrodes being capable of inducing an electric field in said electro-optic material for independently modulating one or more light beams which are incident upon said matrix of electro-optic material.

17. A light modulating array as in claim 16 wherein:

said electrodes are embedded in said matrix material by a process selected from the group consisting of sol-gel deposition, molding, etching of the matrix followed by electrode placement, and micro-machining of the matrix.

18. A system for modulating light comprising:

one or more discrete protrusions formed of electro-optic material, each discrete protrusion being electrically and optically isolated from each other, said protrusions having defined a top face, a bottom face, one or more side faces, and front and back faces;

a plurality of electrodes associated with each of said protrusions, said electrodes being capable of inducing an electric field in said electro-optic material for independently modulating one or more light beams incident upon one of said faces of said protrusions, the light beams being linearly polarized in a first polarization orientation;

a power supply capable of supplying sufficient voltage to induce a desired polarization shift from a first polarization orientation to a second polarization orientation in a beam of polarized light entering said protrusions;

conductive means for conducting electricity from said power supply to said plurality of electrodes;

switching means for controlling application of voltage to said electrodes through said conducting means; and

separation means for separating light of a first polarization orientation from light of a second polarization orientation.

19. The system for modulating light of claim 18 wherein:

said conductive means includes conductive pads which are connected to said electrodes in a configuration to be selected from the group consisting of two conductive pads on the top surface of each protrusion, a conductive pad on each side surface of each protrusion, and a conductive pad on the top surface of each protrusion and a conductive pad on each of one or more electrodes which are associated with the bottom of each protrusion,

20. The system for modulating light of claim 18 wherein:

said separation means is an output polarizer having a polarization orientation, said polarizer being positioned to transmit linearly polarized light output from said protrusions having the same polarization orientation as that of said output polarizer.

21. The system for modulating light of claim 18 wherein:

said separation means is a beam splitter, said beam splitter being positioned so that light of a first polarization orientation is passed through said beam splitter, and light of a second polarization orientation is reflected.

* * * * *