

W. J. A. LONDON.  
 DIFFUSION VANE FOR FORCED DRAFT OR OTHER BLOWER SETS.  
 APPLICATION FILED NOV. 10, 1911.

1,031,944.

Patented July 9, 1912.

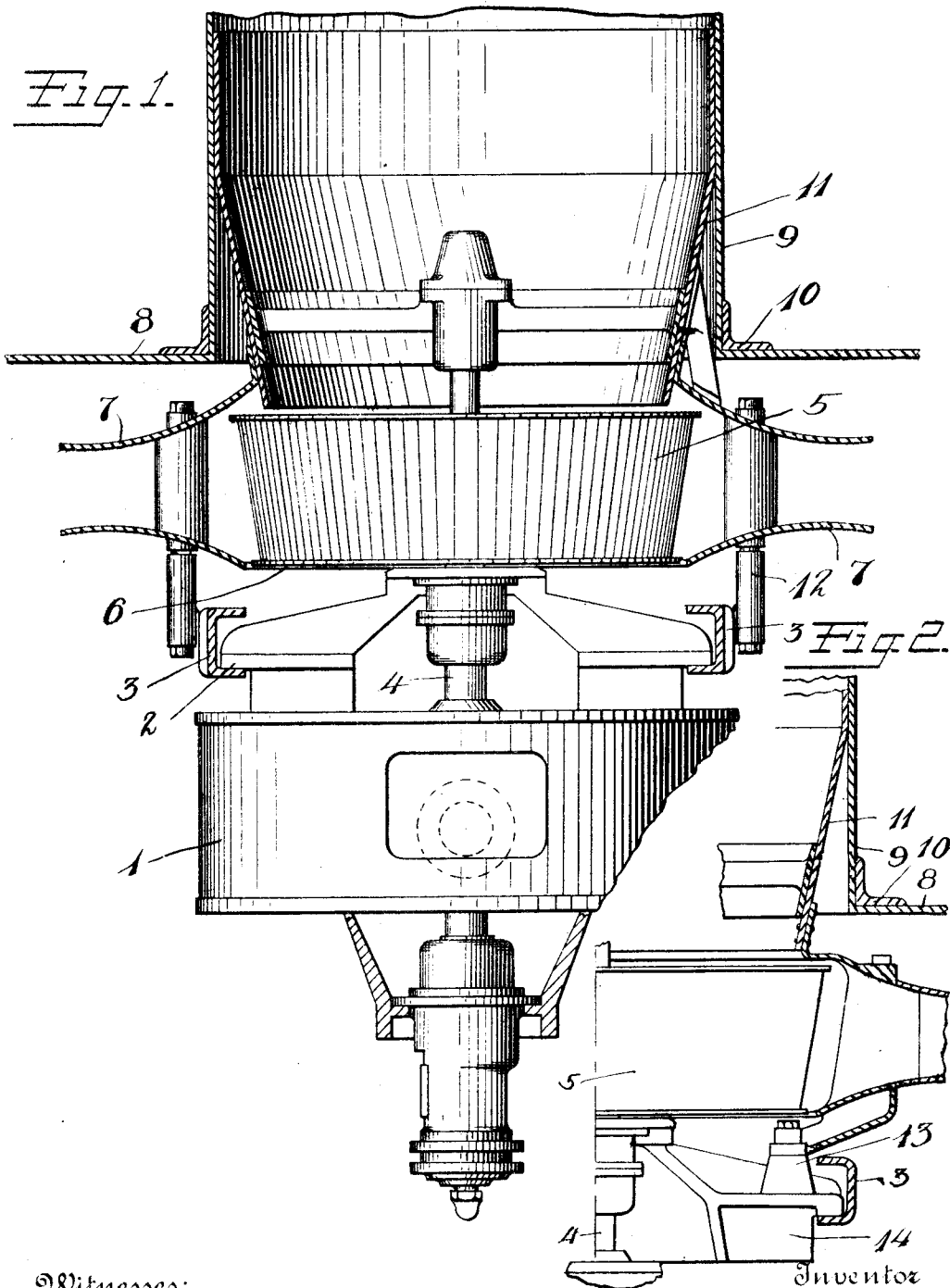

Witnesses:  
*Chas. A. Ford*  
*Geo. W. Hunsicker*

Inventor  
 W. J. A. LONDON  
 By his Attorney  
*Arthur B. Miller*

# UNITED STATES PATENT OFFICE.

WILLIAM JAMES ALBERT LONDON, OF HARTFORD, CONNECTICUT, ASSIGNOR TO THE TERRY STEAM TURBINE COMPANY, OF HARTFORD, CONNECTICUT, A CORPORATION OF CONNECTICUT.

DIFFUSION-VANE FOR FORCED-DRAFT OR OTHER BLOWER SETS.

1,031,944.

Specification of Letters Patent.

Patented July 9, 1912.

Application filed November 10, 1911. Serial No. 659,480.

To all whom it may concern:

Be it known that I, WILLIAM J. A. LONDON, subject of King George V, residing at Hartford, county of Hartford, State of Connecticut, have invented certain new and useful Improvements in Diffusion-Vanes for Forced Draft or other Blower Sets, of which the following is a full, clear, and exact description.

My invention relates to blower sets for forced draft and the like, and is particularly concerned with improvements in the manner of mounting the fan cone and diffusion vanes for such sets.

The object of the invention is to so mount the fan casing and cone, and also the diffusion vanes relative to the fan as to produce the most compact construction, and which will prevent the loss due to the large clearance necessary between the fan and its cone or casing, which is necessary in the constructions in common use.

With these objects in view, the invention consists in a construction and arrangement of parts, the preferred embodiment of which is illustrated in the accompanying drawing, in which,

Figure 1 is a view particularly in section showing one layout of the fan and its casing in combination with the turbine by which the fan may be operated, the parts being in section. Fig. 2 is a fragmentary view similar to Fig. 1 of a modified form of layout.

This invention is particularly, though not exclusively, adapted for use on shipboard in which installations the fan motor and fan are usually supported on girders or I-beams within the body of the ship, while the guide vanes or diffusion vanes are secured to the deck of the boat. In torpedo boats or similar vessels, the construction of the boat is so light that there is a distinct movement between the deck of the boat and the girders supporting the turbine and fan, consequently, a large clearance space must be allowed between the fan itself and the fan cones or casings. In such construction considerable losses in air pressure are found to exist due to these large clearances, for the reason that the pressure on the outside of the fan is greater than that on the inside thereof, and, therefore, there exists a con-

tinual eddying or return of the high pressure air through this clearance space.

The object of the present invention, therefore, is to provide means for reducing this clearance and improving the arrangement of parts generally.

Referring to Fig. 1, 1 indicates a seam turbine or other suitable form of motor, the casing of which is provided with a convenient flange 2, supported upon girders or beams 3 conveniently located within the body of the vessel. Upon the shaft 4 of this motor is mounted the fan 5 which may be of any desired construction. 6 indicates the fan casing which may be provided with any desired number of diffusion vanes 7—7 as shown. In the usual arrangement of apparatus of this character, the fan casing is secured to the deck 8 of the vessel, and consequently owing to the movement of the deck relatively to the girders 3, considerable clearance must be allowed between the fan and its casing to prevent injury of the parts. In the arrangement here illustrated, the intake pipe or funnel 9 is secured to the deck as at 10, in a suitable manner, and the fan casing is provided with a cone 11, slidably mounted within the intake pipe 9, and the casing as a whole is mounted on supporting standards 12, which in Fig. 1 are shown as supported directly by the beams or girders 3. It will be seen, therefore, that the fan casing is rigidly held in proper position closely about the fan, and that the fan cone 11 may readily accommodate itself to any movements of the intake pipe 9 due to movement of the deck 8.

In the embodiment of the invention illustrated in Fig. 2, the parts are in general of the same construction and arrangement as heretofore described, but in this case, the fan casing and vanes, as well as the fan cone, instead of being supported directly upon the girders or supporting beams 3 are supported directly upon standards 13 on the turbine casing 14.

While I have herein described the particular embodiment of my invention, it is to be understood that the same may be altered in details and relative arrangement of parts within the scope of the appended claims.

What I claim is:—

1. In a blower set for vessels, the combi-

nation with a fan and motor therefor rigidly mounted within the body of the vessel, an intake pipe supported from the deck of the vessel, a fan casing also rigidly mounted within the body of the vessel, and a fan cone connecting said intake pipe and movable relatively thereto.

2. In a blower set for vessels, the combination with a fan and a motor therefor, supporting members within the body of the vessel within which said parts are rigidly mounted, a fan casing for said fan also rigidly mounted upon said supporting members, and an intake pipe mounted upon the deck of the vessel and a connection between said intake pipe and said casing slidably mounted relatively to said intake pipe.

3. In a blower set for vessels, the combination with a motor, a fan mounted upon the shaft of said motor, supporting members within the body of the vessel upon which said motor and fan are rigidly mounted, a fan casing for said fan also rigidly mounted

within the body of the vessel, an intake pipe mounted upon the deck of the vessel, and a fan cone rigidly connected with said casing and slidably mounted within said intake pipe.

4. In a blower set, the combination with a fan and motor, a rigid support for said parts, a casing for said fan also mounted on said support, an intake funnel mounted on a separate support, and a fan cone rigidly connected with the said fan casing and movably connected with said intake funnel.

5. In a blower set, the combination with a fan and motor, a rigid support for said parts, a fan casing rigidly supported relatively to said fan and motor, an intake funnel mounted upon a separate support, and a fan cone mounted upon said fan casing and slidable within said intake funnel.

WILLIAM JAMES ALBERT LONDON.

Witnesses:

EDWARD T. FITZ-GERALD,  
J. O. STOUT.