

(19)



(11)

EP 3 623 708 B1

(12)

EUROPEAN PATENT SPECIFICATION

(45) Date of publication and mention of the grant of the patent:

10.05.2023 Bulletin 2023/19

(51) International Patent Classification (IPC):

F24F 1/46 <small>(2011.01)</small>	F24F 1/50 <small>(2011.01)</small>
F24F 1/56 <small>(2011.01)</small>	F24F 1/68 <small>(2011.01)</small>
F24F 1/10 <small>(2011.01)</small>	F24F 1/22 <small>(2011.01)</small>

(21) Application number: **19192518.9**

(52) Cooperative Patent Classification (CPC):

(22) Date of filing: **20.08.2019**

F24F 1/56; F24F 1/10; F24F 1/22; F24F 1/46; F24F 1/50; F24F 1/68; F24F 2221/36

(54) COOLING MODULE AND COOLING APPARATUS

KÜHLMODUL UND KÜHLVORRICHTUNG

MODULE DE REFRROIDISSEMENT ET APPAREIL DE REFRROIDISSEMENT

(84) Designated Contracting States:

AL AT BE BG CH CY CZ DE DK EE ES FI FR GB GR HR HU IE IS IT LI LT LU LV MC MK MT NL NO PL PT RO RS SE SI SK SM TR

- **KURAMOTO, Tetsuhide**
Osaka, 540-6207 (JP)
- **KUWABARA, Osamu**
Osaka, 540-6207 (JP)

(30) Priority: **13.09.2018 JP 2018171249**

(74) Representative: **Eisenführ Speiser Patentanwälte Rechtsanwälte PartGmbB Postfach 31 02 60 80102 München (DE)**

(43) Date of publication of application: **18.03.2020 Bulletin 2020/12**

(73) Proprietor: **Panasonic Intellectual Property Management Co., Ltd. Osaka-shi, Osaka 540-6207 (JP)**

(56) References cited:
EP-A1- 2 461 111 EP-A1- 2 645 008
WO-A1-2014/149482 WO-A2-2008/124637

(72) Inventors:

- **KIYA, Toyoaki**
Osaka, 540-6207 (JP)

EP 3 623 708 B1

Note: Within nine months of the publication of the mention of the grant of the European patent in the European Patent Bulletin, any person may give notice to the European Patent Office of opposition to that patent, in accordance with the Implementing Regulations. Notice of opposition shall not be deemed to have been filed until the opposition fee has been paid. (Art. 99(1) European Patent Convention).

Description

Technical Field

[0001] The present invention relates to a cooling apparatus which includes a plurality of cooling modules.

Background Art

[0002] A condensing unit is carried to an installation location with compressors and a heat exchanger for heat radiation housed in a housing. The number of the compressors and/or the size of the heat exchanger increases depending on the cooling capacity of the condensing unit. Accordingly, in comparison with a condensing unit with low cooling capacity, a condensing unit with high cooling capacity is larger in external size, and smaller in loadable amount in transportation (e.g., a truck or a ship).

[0003] In addition, to deliver condensing units of various cooling capacities in a short period, it is necessary to stock a certain number of condensing units of various cooling capacities.

[0004] In view of this, there are various techniques for achieving the desired cooling capacity by coupling appropriate number of modularized small condensing units (hereinafter referred to as "freezing module") with a relatively low cooling capacity (e.g., PTL 1).

From PTL 2 forming the closest prior art, a refrigerant-storage vessel configuration for a multichannel heat exchanger coil of a condenser (HVAC) is known, which includes an air cooled packaged chiller and at least one air handling unit. The chiller can include one or more refrigerant circuits.

PTL 3 discloses a heat sink for a condensing unit. The condensing unit includes a condenser having a compressor disposed in a cavity formed by the condenser, and a control module arranged on top of the compressor and inside the cavity. The control module is in heat-transferring relation with a heat sink.

[0005] By assembling freezing modules at an installation location after carrying the freezing modules to the installation location, small freezing modules can be loaded to the transportation in an efficient installation manner, and the amount of the modules per transportation can be increased. In addition, various cooling capacities can be set by coupling freezing modules in accordance with the desired cooling capacity, and thus the numbers of the types of the freezing modules to be stocked can be reduced.

Citation List

Patent Literature

[0006]

PTL 1
Japanese Patent Laid-open No. 2016-125773

PTL 2

PCT patent application WO 2008/124637 A2

PTL 3

EP patent application 2 645 008 A1

5 Summary of Invention

Technical Problem

10 **[0007]** Regarding such a configuration of coupling freezing modules to configure a condensing unit of a different capacity, it has been conventionally desired to optimize the arrangements of components that highly require maintenance such that maintenance of such components can be easily performed when the freezing modules are coupled.

15 **[0008]** In response to the above-mentioned desire, an object of the present invention is to increase the ease of maintenance of cooling apparatuses having a configuration in which cooling modules are coupled to each other.

Solution to problem

20 **[0009]** To solve the above-mentioned conventional problems, a cooling module as a part of the present invention as defined in claim 1 includes: a first frame member including an upper section and a lower section; a refrigerant compressor installed on a front side in the first frame member in one of the upper section and the lower section; and an electrical component box installed on the front side in the first frame member in the other of the upper section and the lower section.

25 **[0010]** To solve the above-mentioned conventional problems, a cooling apparatus of the present invention as defined in claim 1 includes a plurality of cooling modules as defined in the previous paragraph and being arranged side by side in a lateral direction wherein the plurality of cooling modules are coupled with each other such that the refrigerant compressors of the plurality of cooling modules are arranged side by side in the lateral direction in a line and that the electrical component boxes of the plurality of cooling modules are arranged side by side in the lateral direction in a line.

45 Advantageous Effects of Invention

[0011] According to the present invention, when cooling modules are coupled with each other, maintenance of components that highly require maintenance can be easily performed.

Brief Description of Drawings

[0012]

55

FIG. 1 is a perspective view illustrating a configuration of a freezing module;
FIG. 2 is a perspective view illustrating a configura-

tion of the freezing module;
 FIG. 3 is a perspective view illustrating a configuration of a heat exchanging module;
 FIG. 4 is a schematic view for describing adjustment of an oil level of a compressor between freezing modules coupled with each other;
 FIG. 5 is a perspective view illustrating a configuration of a freezing apparatus;
 FIG. 6 is a plan view illustrating a configuration of the freezing apparatus;
 FIG. 7 is a perspective view illustrating a configuration of the freezing apparatus; and
 FIG. 8 is a perspective view illustrating a configuration of the freezing apparatus in which illustration of an upper wall of the heat exchanging module is omitted.

Description of Embodiments

[0013] A cooling module and a cooling apparatus according to an embodiment of the present invention are described below with reference to the drawings. While the invention made by the present inventor will be specifically described based on the preferred embodiments, it is not intended to limit the present invention to the following preferred embodiments but the present invention may be further modified within the scope of the invention defined by the appended claims or the equivalents thereof.

[0014] In the following embodiment, the cooling apparatus is a freezing apparatus, and the cooling module is a freezing module. Note that the cooling apparatus is a concept including a freezing apparatus, a refrigeration apparatus, an ultra-low temperature freezer and a combination thereof, and the same similarly applies to the cooling module.

[0015] In addition, in the following description, the front side is the side on which refrigerant compressors 4S and 4L described later are disposed, and the rear side is opposite to the front side. In addition, the left and right are set with respect to the direction from the front side to the rear side.

[0016] Basically, in the diagrams for describing the embodiment, the same elements are denoted with the same reference numerals, and the description thereof may be omitted.

1. Configuration

[0017] Configurations of an embodiment of the present invention are described below with reference to FIG. 1 to FIG. 4. FIG. 1 is a perspective view illustrating a configuration of freezing module 1S. FIG. 2 is a perspective view illustrating a configuration of freezing module 1L of the embodiment of the present invention. FIG. 3 is a perspective view illustrating a configuration of heat exchanging module 1H of the embodiment of the present invention. FIG. 4 is a schematic view for describing adjustment

of oil levels of refrigerant compressors 4S between freezing modules 1S coupled with each other.

1-1. Configuration of Freezing Module

[0018] Rated output P of freezing module 1S illustrated in FIG. 1 is output PS ($P=PS$), and, in freezing module 1S, components are appropriately mounted in frame member 2S of two sections built-up in the vertical direction as illustrated in FIG. 1.

[0019] Specifically, electrical component box 3S in which an electrical component substrate and the like are housed is disposed on the front side in upper section 2Su of frame member 2S, and one refrigerant compressor (hereinafter referred to as "compressor") 4S is installed on the front and right side in lower section 2Sd of frame member 2S. A refrigerant pipe connected with compressor 4S is branched into a plurality of refrigerant pipes LS so as to be arranged to upper section 2Su and connected to air-cooling heat exchanger 5H or water-cooling heat exchangers 7a and 7b as a condenser through a connector as described later.

[0020] With respect to the height of the bottom surface of the leg part fixed at the installation position, the height of the top surface of upper section 2Su is set to H_u , and the height of the top surface of lower section 2Sd is set to H_d .

[0021] In freezing module 1L illustrated in FIG. 2, rated output P is output PL higher than PS that is the rated output of freezing module 1S ($P=PL, PL>PS$). In addition, in freezing module 1L, components are appropriately mounted in frame member 2L of two sections built-up in the vertical direction as in freezing module 1S as illustrated in FIG. 2.

[0022] Specifically, two compressors 4L are arranged side by side in the lateral direction on the front side in lower section 2Ld of frame member 2L, and electrical component box 3L in which electrical component substrate and the like are housed is disposed on the front side in upper section 2Lu of frame member 2L. The refrigerant pipe connected with each compressor 4L is branched into a plurality of refrigerant pipes LL so as to be arranged to upper section 2Lu and connected to water-cooling heat exchangers 7a and 7b or air-cooling heat exchanger 5H as described later.

[0023] With respect to the height of the bottom surface fixed at the installation position, the heights of the top surfaces of upper section 2Lu and lower section 2Ld are identical to the heights of the top surfaces of upper section 2Su and lower section 2Sd of freezing module 1S. In other words, the height of the top surface of upper section 2Lu is set to H_u , and the height of the top surface of lower section 2Ld is set to H_d .

[0024] It is preferable that the height of upper section 2Su of freezing module 1S and the height of upper section 2Lu of freezing module 1L be close to each other, but may not be identical to each other. Likewise, it is preferable that the height of lower section 2Sd of freezing mod-

ule 1S and the height of lower section 2Ld of freezing module 1L be close to each other, but may not be identical to each other.

[0025] In addition, each of freezing modules 1S and 1L is provided with an oil system composed of an oil level sensor, an oil separator, an oil returning valve and the like (omitted in FIG. 1 and FIG. 2). The oil system is described later.

[0026] In the following description, freezing module 1S and freezing module 1L are referred to as "freezing module 1" when they are not discriminated from each other, and compressor 4S and compressor 4L are referred to as "compressor 4" when they are not discriminated from each other.

[0027] Note that freezing module 1 may be used not only in a configuration in which a plurality of freezing modules 1 are coupled to each other to serve as a freezing apparatus as described later, but also in a configuration in which single freezing module 1 serves as a freezing apparatus.

1-2. Configuration of Heat Exchanging Module

[0028] Heat exchanging module 1H illustrated in FIG. 3 includes frame member 2H, air-cooling heat exchanger 5H disposed in the rear, left and right frames of frame member 2H, and blower 6H serving as the upper wall of frame member 2H.

[0029] Frame member 2H is configured to have a size capable of accommodating two freezing modules 1 arranged side by side in the lateral direction. Specifically, frame member 2H can accommodate freezing modules 1S and 1L in any of the following three states: (1) a state where two freezing modules 1S are arranged side by side in the lateral direction, (2) a state where two freezing modules 1L are arranged side by side in the lateral direction, and (3) a state where freezing module 1S and freezing module 1L are arranged side by side in the lateral direction. In addition, the front side of frame member 2H is open, and thus freezing modules 1S and 1L may be installed from the front side.

[0030] Blower 6H includes two air blasting apparatuses 60 arranged side by side in the lateral direction. When air blasting apparatuses 60 are activated, air passes through air-cooling heat exchanger 5H, and then the air is discharged from frame member 2H. When passing through air-cooling heat exchanger 5H, the air exchanges heat with refrigerant flowing in air-cooling heat exchanger 5H, and thus cools and condenses the refrigerant.

1-3. Adjustment of Oil Level

[0031] With reference to FIG. 4, a method of adjusting the oil level of compressor 4 between a plurality of freezing modules 1 coupled with each other is described. Here, a case where two freezing modules 1S are coupled with each other is described. In FIG. 4, the solid line indicates

a refrigerant pipe and the broken line indicates an oil pipe. Note that, in FIG. 4, illustration of the system of the refrigerant pipe is simplified for convenience of description.

[0032] Each compressor 4S is provided with oil level sensor 40. Oil level sensor 40 detects the oil level in the casing of compressor 4S. In the present embodiment, oil level sensor 40 is a float sensor, and detects the upper limit level and the lower limit level of the oil in the casing of compressor 4S.

[0033] Intake pipe LS0 (refrigerant pipe LS) is connected with the intake port of each compressor 4S. In addition, one end of discharge pipe LS1 (refrigerant pipe LS) is connected with the discharge port of each compressor 4S, and the other end of discharge pipe LS1 is connected with an intermediate portion of oil separator 41 in the height direction. In addition, high-pressure pipe LS2 is fixed at an upper portion of each oil separator 41.

[0034] Oil separator 41 captures oil contained in high-pressure refrigerant discharged from compressor 4S by separating the oil from the refrigerant. Oil pipe LRa is fixed at a lower portion of each oil separator 41, and oil returning pipe LR for returning the captured oil to compressor 4S is branched from oil pipe LRa. Oil returning valve 42 whose opening can be changed in accordance with the oil returning amount is interposed in each oil returning pipe LR.

[0035] Here, refrigerant intake pipes LS0 of freezing modules 1S are connected with each other with connector C1 therebetween, and refrigerant high-pressure pipes LS2 are connected with each other with connector C2 therebetween. In addition, communication pipe 41a communicated with the interior of oil separator 41 is fixed at an upper portion of each oil separator 41, and communication pipes 41a are connected with each other with connector C3 therebetween. In addition, oil returning pipes LR of freezing modules 1S are connected with each other with connector C4 therebetween.

[0036] The flow rate of oil supplied from oil separator 41 to compressor 4S is adjusted by controlling the opening of oil returning valve 42 connected with the compressor, such that the oil surface in the compressor case is set between the upper limit and the lower limit, according to a detection result of the oil level sensor 40.

[0037] In addition, when the oil surfaces in two oil separators 41 differ from each other, connector C4 connecting the oil part of oil separator 41 serves as a siphon and thus the heights of the oil surfaces in oil separators 41 are substantially equalized.

1-4. Freezing Apparatus 10A

[0038] Freezing apparatus 10A is described with reference to FIG. 5 and FIG. 6. FIG. 5 is a perspective view illustrating a configuration of freezing apparatus 10A. FIG. 6 is a plan view illustrating a configuration of freezing apparatus 10A.

[0039] In freezing apparatus 10A illustrated in FIG. 5,

two freezing modules 1L are coupled with each other in the lateral direction. Specifically, frame members 2L of freezing modules 1L are connected with each other with metal coupling fitting 20 at same height or substantially same height as those of upper section 2Lu and lower section 2Ld on the front and rear sides. Metal coupling fittings 20 are fixed to frame members 2L of freezing modules 1L at at least left and right both ends by a publicly known method such as a bolting or welding.

[0040] Freezing modules 1L are coupled with each other with electrical component box 3L and compressor 4L facing forward. As a result, electrical component boxes 3L are arranged side by side in the lateral direction at the same height (or at substantially the same height) on the front side in freezing apparatus 10A, and compressors 4L are arranged side by side in the lateral direction at the same height (or at substantially the same height) at lower section 2Ld.

[0041] In addition, as illustrated in FIG. 6, on the rear side in upper section 2Lu in each freezing module 1L, two water-cooling heat exchangers 7a and 7b are arranged side by side in the lateral direction.

[0042] Each of connecting parts (ends) of refrigerant pipes LL of each freezing module 1L extends upward through a rear portion of upper section 2Lu of frame member 2L. Refrigerant pipes LL are connected, by connector C5, C6, C7 and C8, with water-cooling heat exchangers 7a and 7b installed in the corresponding freezing module 1L. In addition, water-cooling heat exchangers 7a and 7b are connected with two headers H arranged in the vertical direction with branched pipe h therebetween. With this configuration, water supplied from one of two headers H and refrigerant supplied from refrigerant pipe LL exchange heat, and the refrigerant is cooled. Then, the heated water is collected at the other header H, and discharged to the outside.

[0043] In addition, refrigerant pipe LL that outputs, to the cooling load side, refrigerant having been subjected to heat exchange at water-cooling heat exchangers 7a and 7b in each freezing module 1L is joined at the coupling part (connector C9), and refrigerant coming back from the cooling load is branched at the coupling part (connector C1) and taken by each freezing module 1L through intake-refrigerant pipe LL.

[0044] In addition, on the rear side in electrical component box 3L, shielding plate 8 is formed in an L-shape with an upper wall and a rear wall extending downward from the rear end of the upper wall. The upper and rear walls are integrally formed.

1-5. Freezing Apparatus 10B

[0045] Freezing apparatus 10B is described with reference to FIG. 7 and FIG. 8. FIG. 7 is a perspective view illustrating a configuration of freezing apparatus 10B. FIG. 8 is a perspective view illustrating a configuration of freezing apparatus 10B in which illustration of the upper wall of heat exchanging module 1H is omitted.

[0046] As illustrated in FIG. 7, freezing apparatus 10B includes freezing modules 1S and 1L arranged side by side in the lateral direction in heat exchanging module 1H. Freezing modules 1S and 1L are housed in heat exchanging module 1H in the state where electrical component boxes 3S and 3L and compressors 4S and 4L face forward. As a result, at the front frame where air-cooling heat exchanger 5H is not disposed, electrical component boxes 3S and 3L are arranged side by side in the lateral direction at the same height (or substantially same height) in the upper section, and compressors 4S and 4L are arranged side by side in the lateral direction at the same height (or substantially same height) in the lower section.

[0047] As illustrated in FIG. 8, a plurality of connecting parts (ends) of refrigerant pipes LS and LL of freezing modules 1S and 1L extend upward through rear portions of upper sections 2Su and 2Lu of frame members 2S and 2L. Of the extending connecting parts, connecting parts of some refrigerant pipe LS and refrigerant pipe LL are connected by connectors C2, C10, C11 and C12. The connecting parts of the remaining refrigerant pipes LS and LL are closed with plugs. Note that connector C10 connects refrigerant pipes LS and LL of the inter cooler entrance of compressors 4S and 4L. Connector C11 connects refrigerant pipes LS and LL of the inter cooler outlet of compressors 4S and 4L. Connector C12 connects refrigerant pipes LS and LL of the air-cooling heat exchanger 5H (gas cooler) outlet.

[0048] In the case where freezing modules 1S and 1L are combined with heat exchanging module 1H, the refrigerant pipe, that is provided at the side surface, the back surface or the front surface of a lower portion of freezing modules 1S and 1L, is used as a refrigerant pipe to output refrigerant to the cooling load, and therefore refrigerant pipes LS and LL having an ejection port (connection port) on upper sections 2Su and 2Lu of freezing modules 1S and 1L are not used. For this reason, the ejection port (connection port) is closed with a plug.

[0049] Other configurations are similar to those of freezing apparatus 10A, and therefore the description thereof is omitted.

2. Operation and Effect

[0050]

(1) In upper sections 2Su and 2Lu or lower sections 2Sd and 2Ld of frame members 2S and 2L of freezing modules 1S and 1L, compressors 4S and 4L and electrical component boxes 3S and 3L are arranged on the front side in frame members 2S and 2L. With this configuration, when freezing apparatus 10A and 10B are configured by coupling a plurality of freezing modules 1S and 1L, compressors 4S and 4L can be arranged side by side on the front side in the same section (in the present embodiment, lower section), and electrical component boxes 3S and 3L can be

arranged side by side on the front side in the same section (in the present embodiment, upper section). That is, in freezing apparatus 10A and 10B, it is possible to easily access compressors 4S and 4L and electrical component boxes 3S and 3L that highly require maintenance because of their high importance and high cost. Accordingly, according to the embodiment of the present invention, maintenance of components that highly require maintenance can be easily performed.

(2) Since compressors 4S and 4L, which are heavy members, are disposed in lower sections 2Sd and 2Ld of frame members 2S and 2L of freezing modules 1S and 1L, the gravity centers of freezing modules 1S and 1L and freezing apparatuses 10A and 10B are located near the bottom, and thus a stable and hard-to-fall structure can be achieved.

(3) Since refrigerant pipes LS and LL of freezing modules 1S and 1L and/or the connection port of the oil system of compressors 4S and 4L are aligned on the rear side, connection between refrigerant pipes LS and LL and the oil system can be easily performed in freezing modules 1S and 1L.

(4) Since electrical component boxes 3S and 3L are provided with L-shaped shielding plate 8, electrical component boxes 3S and 3L can be protected from rain, coolant leaked from water-cooling heat exchangers 7a and 7b and the like even when electrical component boxes 3S and 3L are provided in upper sections 2Su and 2Lu of freezing modules 1S and 1L as in the present embodiment.

3. Other points

[0051]

(1) In contrast to the embodiment, electrical component boxes 3S and 3L may be disposed in lower sections 2Sd and 2Ld, and compressors 4S and 4L may be disposed in upper sections 2Su and 2Lu.

(2) While two freezing modules 1 are coupled to each other in the embodiment, three or more freezing modules 1 may be coupled to each other.

(3) While two freezing modules 1, and one heat exchanging module 1H are mounted to configure a cooling apparatus in the embodiment, one freezing module 1, and one heat exchanging module 1H may be mounted to configure a cooling apparatus.

Industrial Applicability

[0052] According to the present invention, maintenance of components that highly require maintenance can be easily performed, and thus the present invention provides high industrial applicability.

Reference Signs List

[0053]

- | | |
|----|---|
| 5 | 1, 1S, 1L Freezing module (Cooling module) |
| | 1H Heat exchanging module |
| | 2S, 2L, 2H Frame member |
| | 2Su, 2Lu Upper section |
| | 2Sd, 2Ld Lower section |
| 10 | 3S, 3L Electrical component box |
| | 4S, 4L Refrigerant compressor |
| | 5H Air-cooling heat exchanger |
| | 6H Blower |
| | 7a, 7b Water-cooling heat exchanger |
| 15 | 8 Shielding plate |
| | 20 Metal coupling fitting |
| | 10, 10A, 10B Freezing apparatus (Cooling apparatus) |
| | 40 Oil level sensor |
| 20 | 41 Oil separator |
| | 42 Oil returning valve |
| | 60 Air blasting apparatus |
| | C1 to C12 Connector |
| | H Header |
| 25 | h Branched pipe |
| | LS, LL Refrigerant pipe |
| | LS0 Intake pipe |
| | LS1 Discharge pipe |
| | LS2 High-pressure pipe |
| 30 | LR Oil returning pipe |
| | LRa Oil pipe |

Claims

35

1. A cooling apparatus comprising:

a plurality of cooling modules (1S, 1L) being arranged side by side in a lateral direction;
wherein each of the cooling modules (1S, 1L) comprises:

40

a first frame member (2S, 2L) including an upper section (2Su, 2Lu) and a lower section (2Sd, 2Ld);

45

a refrigerant compressor (4S, 4L) installed on a front side in the first frame member (2S, 2L) in one of the upper section (2Su, 2Lu) and the lower section (2Sd, 2Ld); and an electrical component box (3S, 3L) installed on the front side in the first frame member (2S, 2L) in the other of the upper section (2Su, 2Lu) and the lower section (2Sd, 2Ld), and

50

wherein the plurality of cooling modules (1S, 1L) are coupled with each other such that the refrigerant compressors (4S, 4L) of the plurality of cooling modules (1S, 1L) are

arranged side by side in the lateral direction in a line and that the electrical component boxes (3S, 3L) of the plurality of cooling modules (1S, 1L) are arranged side by side in the lateral direction in a line.

2. The cooling apparatus according to claim 1,

wherein the refrigerant compressor (4S, 4L) is installed in the lower section (2Sd, 2Ld); and wherein the electrical component box (3S, 3L) is installed in the upper section (2Su, 2Lu).

3. The cooling apparatus according to claim 2, further comprising a shielding member (8) configured to shield at least a part of the electrical component box (3S, 3L).

4. The cooling apparatus according to claim 1 or 2, wherein a plurality of the refrigerant compressors (4S, 4L) are arranged side by side in a lateral direction.

5. The cooling apparatus according to any one of claims 1 to 3, wherein, in the upper section (2Su, 2Lu) or the lower section (2Sd, 2Ld), a refrigerant pipe (LS, LL) is provided on a rear side of the first frame member (2S, 2L).

6. The cooling apparatus according to any one of claims 1 to 5, further comprising a heat exchanging module (1H), wherein the heat exchanging module (1H) comprises:

a second frame member (2H) including an upper section (2Su, 2Lu) and a lower section (2Sd, 2Ld);

an air-cooling heat exchanger (5H) disposed in a rear frame part, a left frame part and a right frame part of the second frame member (2H), the air-cooling heat exchanger (5H) being configured to cause heat exchange between air and refrigerant fed by the refrigerant compressor (4S, 4L); and

an air blower (6H) provided at an upper part of the second frame member (2H) and configured to send air to the air-cooling heat exchanger (5H), and

wherein the cooling module (1S, 1L) is disposed in the second frame member (2H).

Patentansprüche

1. Kühlvorrichtung, umfassend:

eine Vielzahl von Kühlmodulen (1S, 1L), die ne-

beneinander in einer lateralen Richtung angeordnet sind;

wobei jedes der Kühlmodule (1S, 1L) umfasst:

ein erstes Rahmenelement (2S, 2L), das einen oberen Abschnitt (2Su, 2Lu) und einen unteren Abschnitt (2Sd, 2Ld) aufweist; einen Kältemittelverdichter (4S, 4L), der auf einer Vorderseite in das erste Rahmenelement (2S, 2L) in einem von dem oberen Abschnitt (2Su, 2Lu) und dem unteren Abschnitt (2Sd, 2Ld) eingebaut ist; und einen Kasten elektrischer Komponenten (3S, 3L), der auf der Vorderseite in das erste Rahmenelement (2S, 2L) in dem anderen von dem oberen Abschnitt (2Su, 2Lu) und dem unteren Abschnitt (2Sd, 2Ld) eingebaut ist, und

wobei die Vielzahl von Kühlmodulen (1S, 1L) derart miteinander verbunden sind, dass die Kältemittelverdichter (4S, 4L) der Vielzahl von Kühlmodulen (1S, 1L) nebeneinander in der lateralen Richtung in einer Linie angeordnet sind und dass die Kästen elektrischer Komponenten (3S, 3L) der Vielzahl von Kühlmodulen (1S, 1L) nebeneinander in der lateralen Richtung in einer Linie angeordnet sind.

2. Kühlvorrichtung nach Anspruch 1,

wobei der Kältemittelverdichter (4S, 4L) in den unteren Abschnitt (2Sd, 2Ld) eingebaut ist; und wobei der Kasten elektrischer Komponenten (3S, 3L) in den oberen Abschnitt (2Su, 2Lu) eingebaut ist.

3. Kühlvorrichtung nach Anspruch 2, ferner umfassend ein Abschirmelement (8), das dazu ausgestaltet ist, mindestens einen Teil des Kastens elektrischer Komponenten (3S, 3L) abzuschirmen.

4. Kühlvorrichtung nach Anspruch 1 oder 2, wobei eine Vielzahl der Kältemittelverdichter (4S, 4L) nebeneinander in einer lateralen Richtung angeordnet sind.

5. Kühlvorrichtung nach einem der Ansprüche 1 bis 3, wobei in dem oberen Abschnitt (2Su, 2Lu) oder dem unteren Abschnitt (2Sd, 2Ld) eine Kältemittelrohrleitung (LS, LL) auf einer Rückseite des ersten Rahmenelements (2S, 2L) vorgesehen ist.

6. Kühlvorrichtung nach einem der Ansprüche 1 bis 5, ferner umfassend ein Wärmetauschermodul (1H), wobei das Wärmetauschermodul (1H) umfasst:

ein zweites Rahmenelement (2H), das einen oberen Abschnitt (2Su, 2Lu) und einen unteren

Abschnitt (2Sd, 2Ld) aufweist;
 einen Luftkühlwärmetauscher (5H), der in einem hinteren Rahmenteil, einem linken Rahmenteil und einem rechten Rahmenteil des zweiten Rahmenelements (2H) angeordnet ist, wobei der Luftkühlwärmetauscher (5H) dazu eingerichtet ist, einen Wärmeaustausch zwischen Luft und einem Kältemittel, das von dem Kältemittelverdichter (4S, 4L) zugeführt wird, zu bewirken; und
 ein Luftgebläse (6H), das an einem oberen Teil des zweiten Rahmenelements (2H) vorgesehen und dazu eingerichtet ist, Luft zu dem Luftkühlwärmetauscher (5H) zu schicken, und wobei das Kühlmodul (1S, 1L) in dem zweiten Rahmenelement (2H) angeordnet ist.

Revendications

1. Appareil de refroidissement comprenant :

une pluralité de modules de refroidissement (1S, 1L) agencés côte à côte dans une direction latérale ;
 chacun des modules de refroidissement (1S, 1L) comprenant :

un premier élément de cadre (2S, 2L) incluant une section supérieure (2Su, 2Lu) et une section inférieure (2Sd, 2Ld) ;
 un compresseur de fluide frigorigène (4S, 4L) installé sur un côté avant dans le premier élément de cadre (2S, 2L) dans l'une parmi la section supérieure (2Su, 2Lu) et la section inférieure (2Sd, 2Ld) ; et
 une boîte à composants électriques (3S, 3L) installée sur le côté avant dans le premier élément de cadre (2S, 2L) dans l'autre parmi la section supérieure (2Su, 2Lu) et la section inférieure (2Sd, 2Ld) et
 la pluralité de modules de refroidissement (1S, 1L) étant accouplés l'un à l'autre de telle sorte que les compresseurs de fluide frigorigène (4S, 4L) de la pluralité de modules de refroidissement (1S, 1L) sont agencés côte à côte dans la direction latérale sur une ligne et que les boîtes à composants électriques (3S, 3L) de la pluralité de modules de refroidissement (1S, 1L) sont agencées côte à côte dans la direction latérale sur une ligne.

2. Appareil de refroidissement selon la revendication 1,

le compresseur de fluide frigorigène (4S, 4L) étant installé dans la section inférieure (2Sd, 2Ld) ; et

la boîte à composants électriques (3S, 3L) étant installée dans la section supérieure (2Su, 2Lu).

3. Appareil de refroidissement selon la revendication 2, comprenant en outre un élément de blindage (8) conçu pour protéger au moins une partie de la boîte à composants électriques (3S, 3L).

4. Appareil de refroidissement selon la revendication 1 ou 2, une pluralité des compresseurs de fluide frigorigène (4S, 4L) étant agencés côte à côte dans une direction latérale.

5. Appareil de refroidissement selon l'une quelconque des revendications 1 à 3, dans lequel, dans la section supérieure (2Su, 2Lu) ou la section inférieure (2Sd, 2Ld), un tuyau de fluide frigorigène (LS, LL) est prévu sur un côté arrière du premier élément de cadre (2S, 2L).

6. Appareil de refroidissement selon l'une quelconque des revendications 1 à 5, comprenant en outre un module d'échange de chaleur (1H),
 le module d'échange de chaleur (1H) comprenant :

un deuxième élément de cadre (2H) incluant une section supérieure (2Su, 2Lu) et une section inférieure (2Sd, 2Ld) ;

un échangeur de chaleur de refroidissement d'air (5H) disposé dans une partie de cadre arrière, une partie de cadre gauche et une partie de cadre droite du deuxième élément de cadre (2H), l'échangeur de chaleur de refroidissement d'air (5H) étant conçu pour provoquer un échange de chaleur entre l'air et le fluide frigorigène alimenté par le compresseur de fluide frigorigène (4S, 4L) ; et

un ventilateur (6H) prévu au niveau d'une partie supérieure du deuxième élément de cadre (2H) et conçu pour envoyer de l'air à l'échangeur de chaleur de refroidissement d'air (5H) et le module de refroidissement (1S, 1L) étant disposé dans le deuxième élément de cadre (2H).

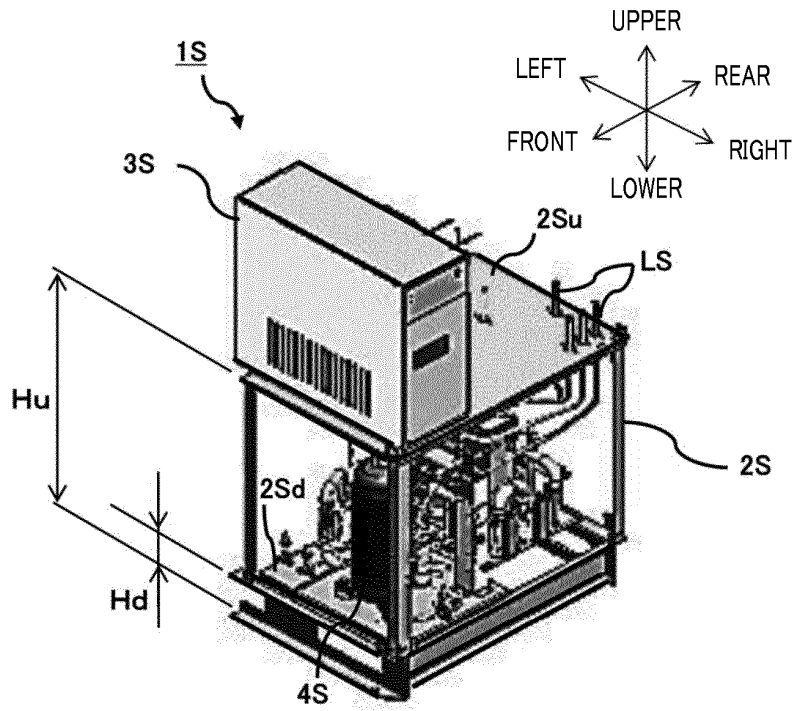

FIG. 1

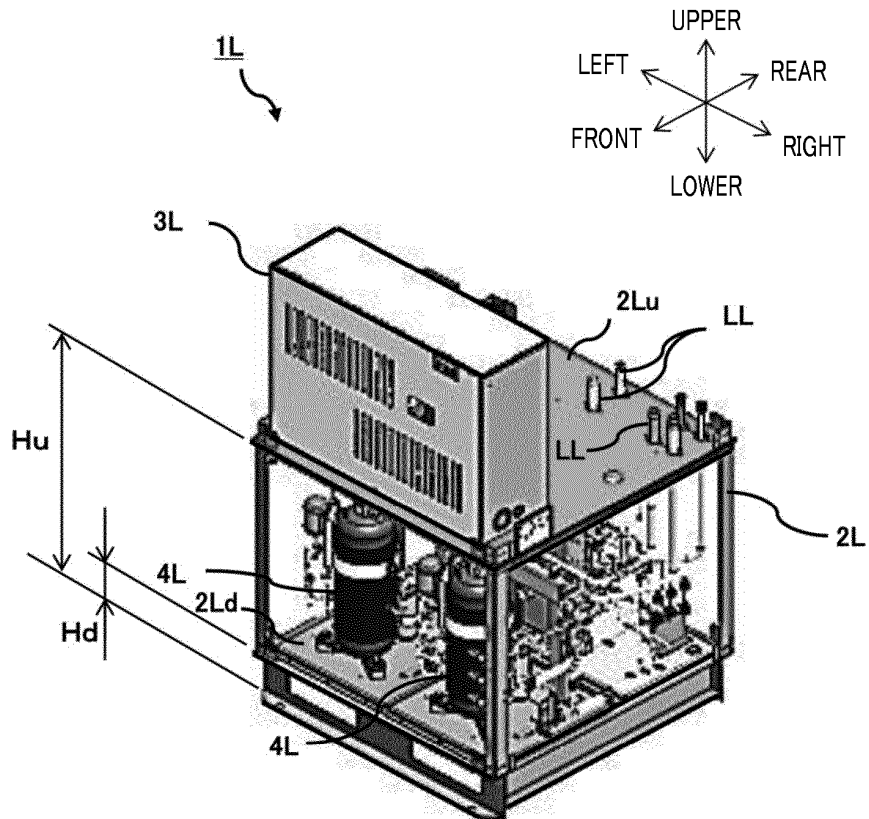

FIG. 2

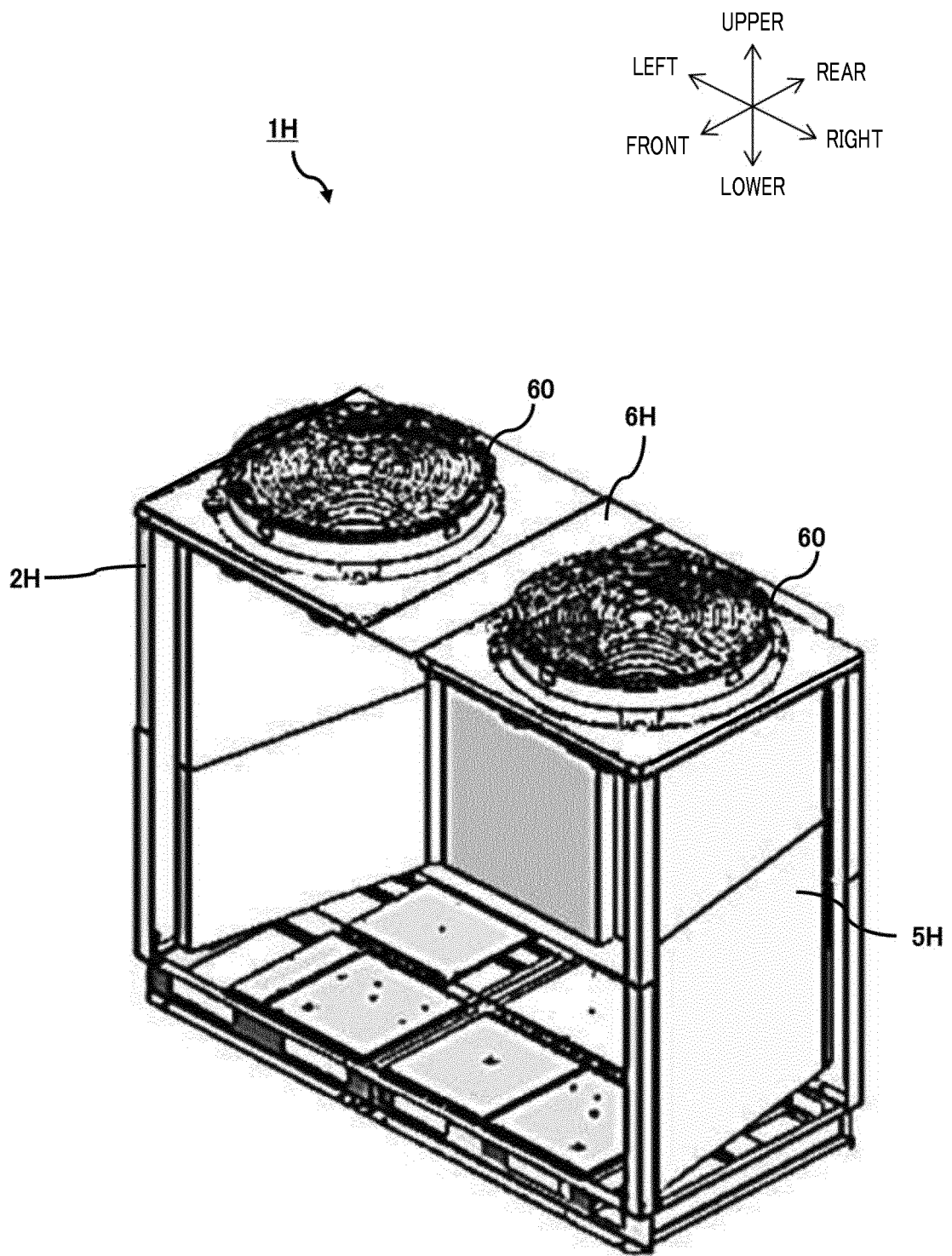

FIG. 3

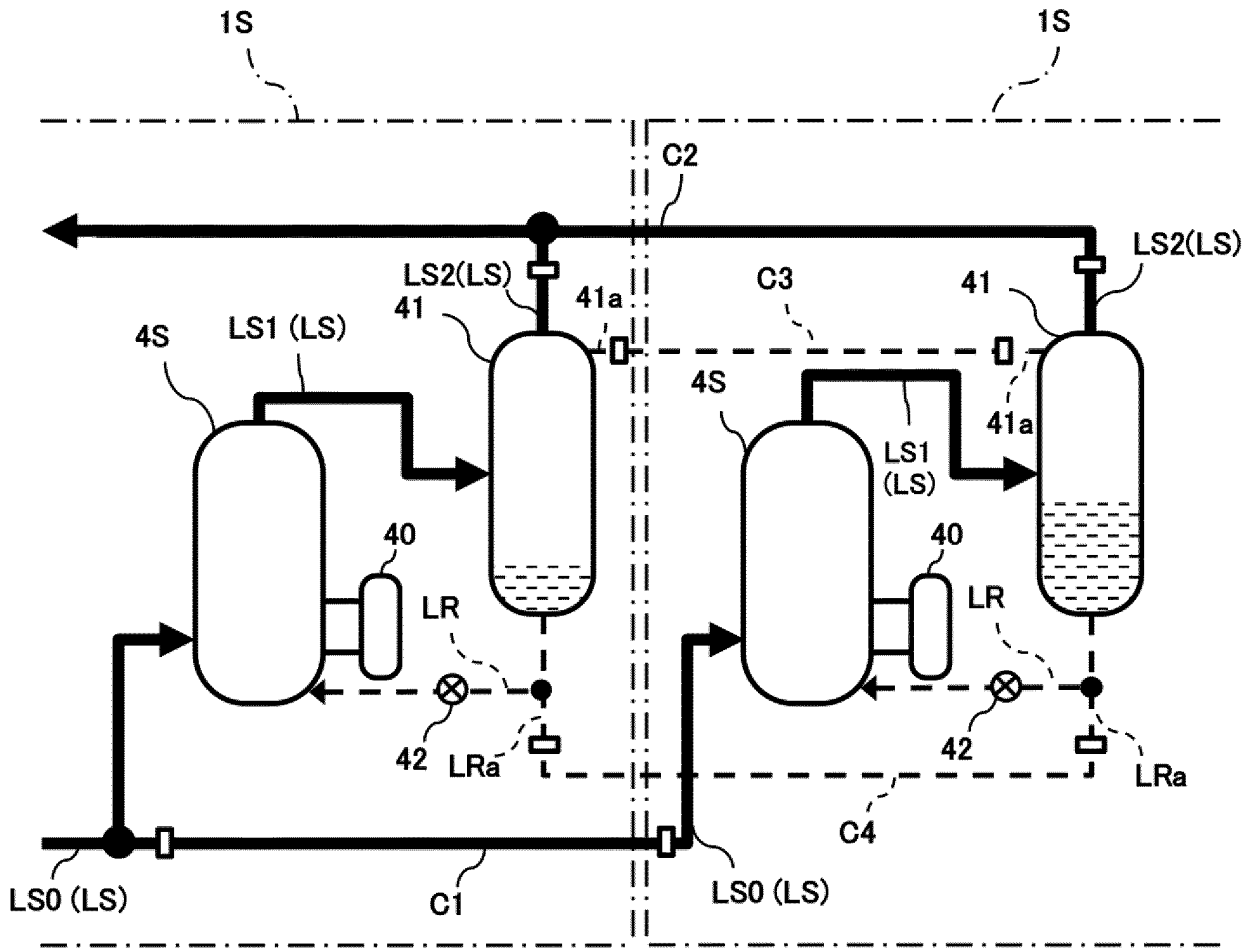

FIG. 4

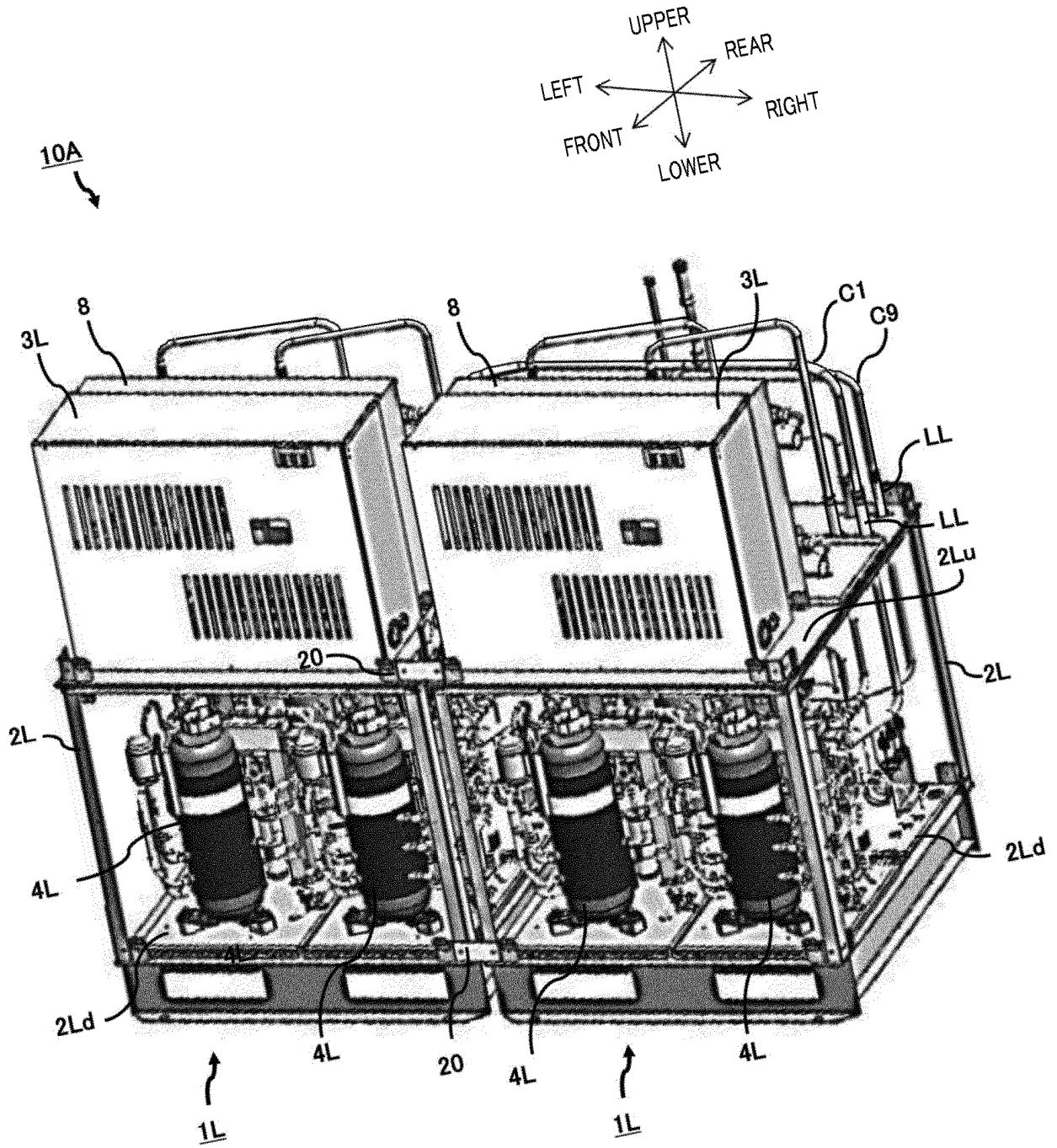

FIG. 5

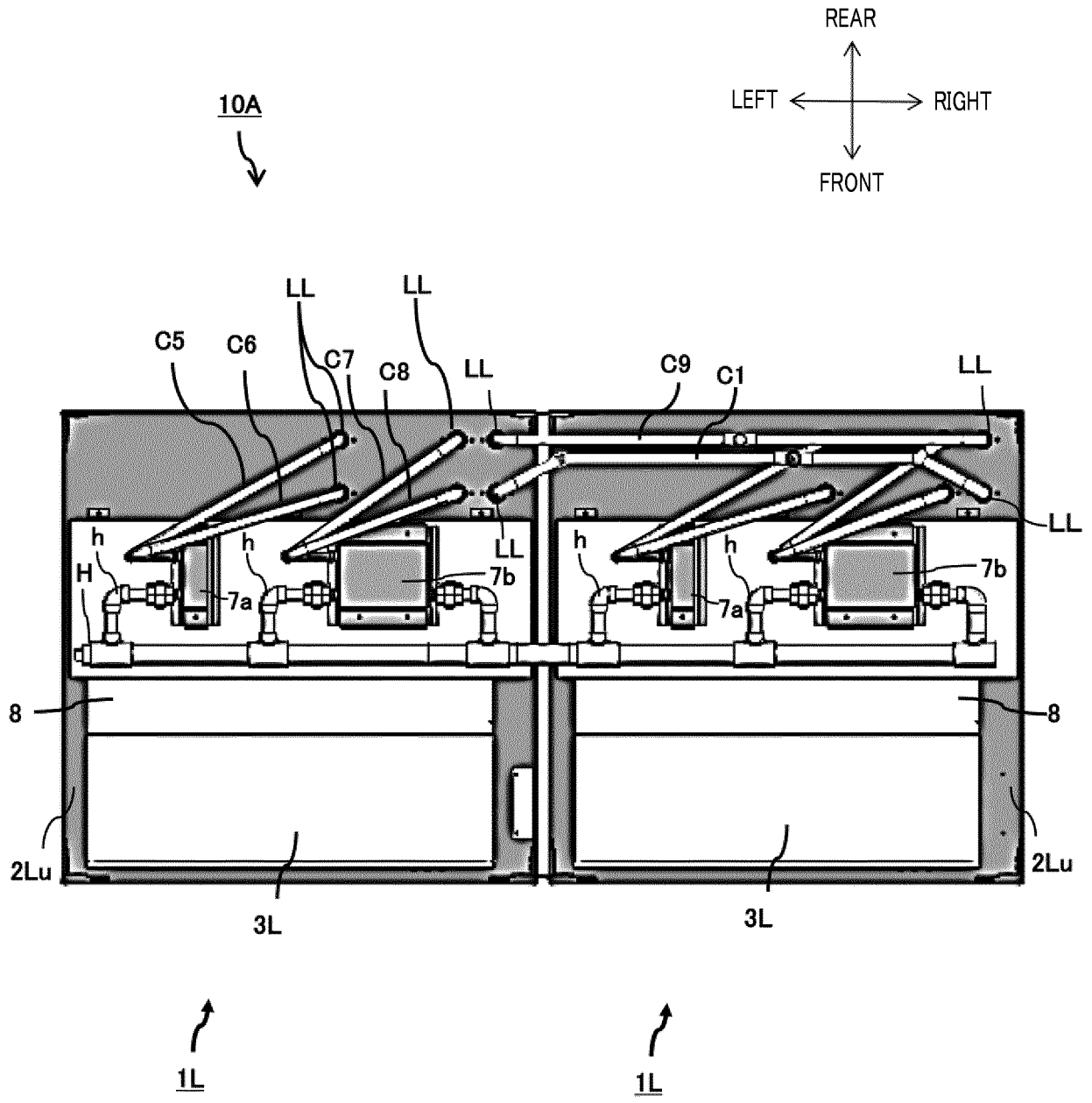

FIG. 6

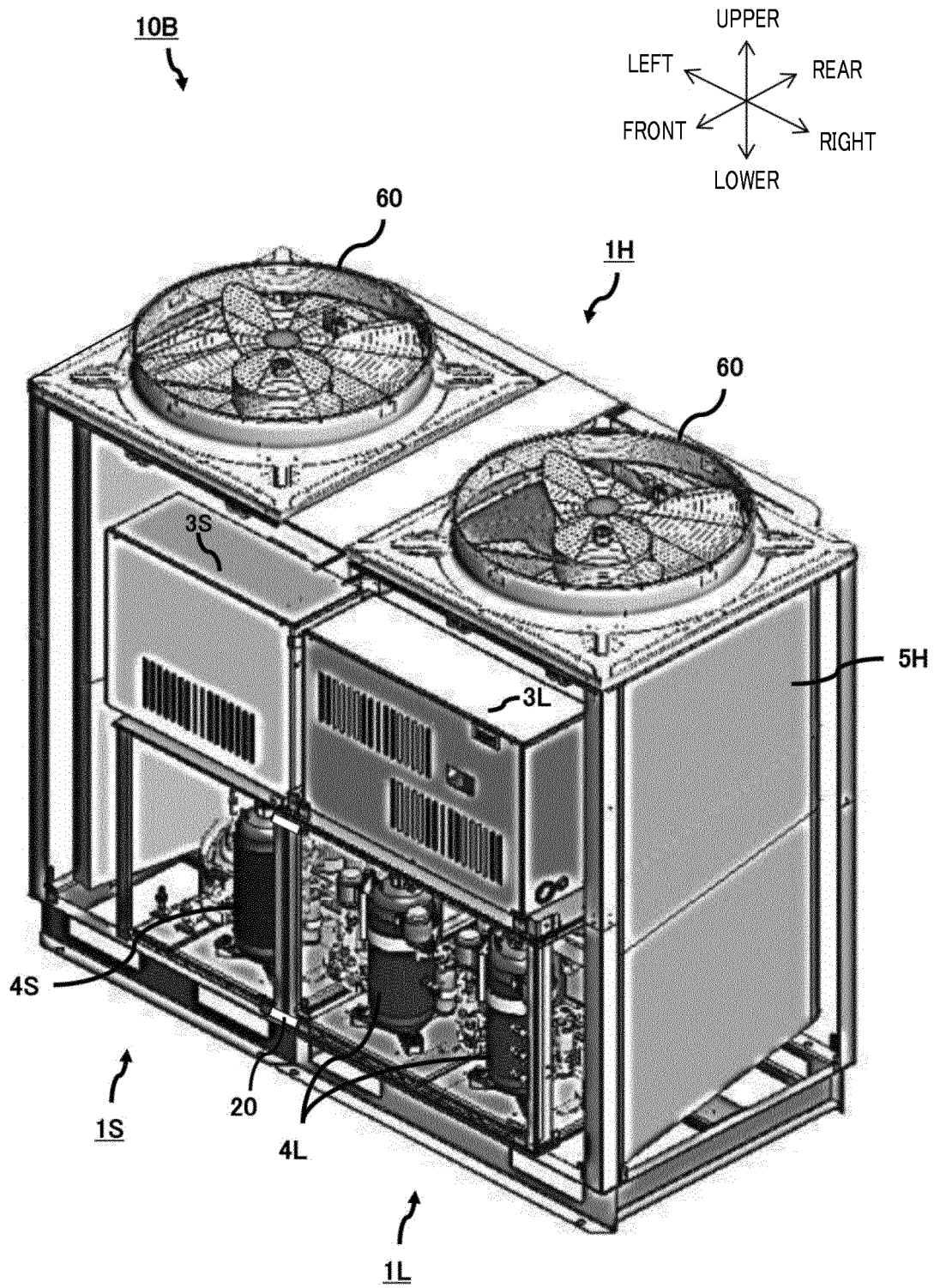

FIG. 7

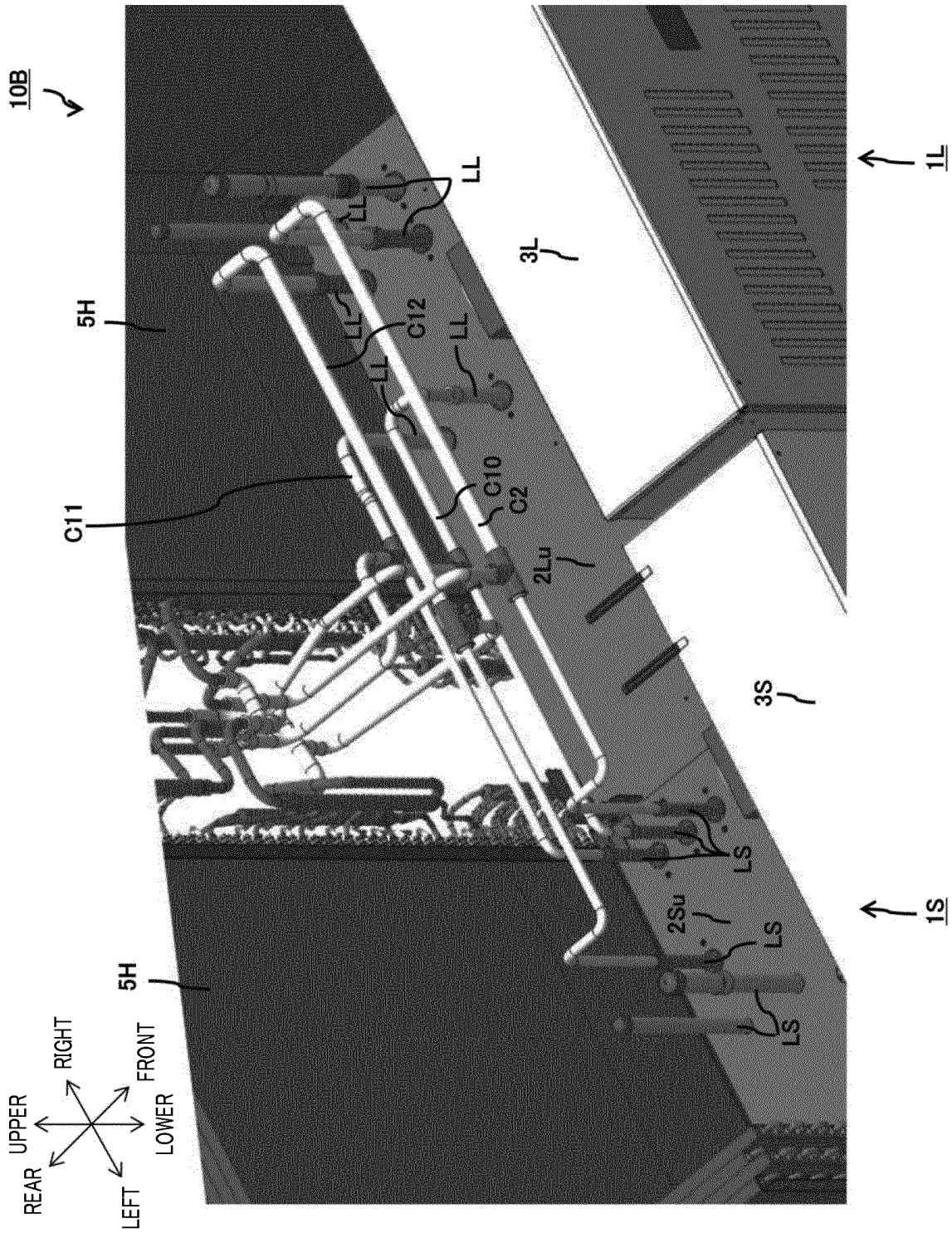

FIG. 8

REFERENCES CITED IN THE DESCRIPTION

This list of references cited by the applicant is for the reader's convenience only. It does not form part of the European patent document. Even though great care has been taken in compiling the references, errors or omissions cannot be excluded and the EPO disclaims all liability in this regard.

Patent documents cited in the description

- JP 2016125773 A [0006]
- WO 2008124637 A2 [0006]
- EP 2645008 A1 [0006]