

(19) World Intellectual Property Organization
International Bureau



(43) International Publication Date
7 October 2004 (07.10.2004)

PCT

(10) International Publication Number
WO 2004/086289 A2

- (51) International Patent Classification⁷: **G06K**
- (21) International Application Number: PCT/US2004/009070
- (22) International Filing Date: 24 March 2004 (24.03.2004)
- (25) Filing Language: English
- (26) Publication Language: English
- (30) Priority Data:
60/457,263 24 March 2003 (24.03.2003) US
10/807,775 23 March 2004 (23.03.2004) US
- (71) Applicant: **ALIEN TECHNOLOGY CORPORATION**
[US/US]; 18220 Butterfield Boulevard, Morgan Hill, CA 95037 (US).
- (72) Inventors: **GENGEL, Glen, W.**; 690 Tevis Trail, Hollister, CA 95023 (US). **HADLEY, Mark, A.**; 39887 Cedar Boulevard, #353, Newark, CA 94560 (US). **POUNDS, Tom**; 17380 Valley Oak Dr., Monte Sereno, CA 95030 (US). **SCHATZ, Kenneth, D.**; 1445 Cerro Verde, San Jose, CA 95120 (US). **DRZAIC, Paul, S.**; 506 Calle Florencia, Morgan Hill, CA 95037 (US).
- (74) Agents: **SHELLER, James, C.** et al.; Blakely, Sokoloff, Taylor & Zafman LLP, 7th floor, 12400 Wilshire Boulevard, Los Angeles, CA 90025 (US).
- (81) Designated States (*unless otherwise indicated, for every kind of national protection available*): AE, AG, AL, AM, AT, AU, AZ, BA, BB, BG, BR, BW, BY, BZ, CA, CH, CN, CO, CR, CU, CZ, DE, DK, DM, DZ, EC, EE, EG, ES, FI, GB, GD, GE, GH, GM, HR, HU, ID, IL, IN, IS, JP, KE, KG, KP, KR, KZ, LC, LK, LR, LS, LT, LU, LV, MA, MD, MG, MK, MN, MW, MX, MZ, NA, NI, NO, NZ, OM, PG, PH, PL, PT, RO, RU, SC, SD, SE, SG, SK, SL, SY, TJ, TM, TN, TR, TT, TZ, UA, UG, US, UZ, VC, VN, YU, ZA, ZM, ZW.
- (84) Designated States (*unless otherwise indicated, for every kind of regional protection available*): ARIPO (BW, GH, GM, KE, LS, MW, MZ, SD, SL, SZ, TZ, UG, ZM, ZW), Eurasian (AM, AZ, BY, KG, KZ, MD, RU, TJ, TM), European (AT, BE, BG, CH, CY, CZ, DE, DK, EE, ES, FI, FR, GB, GR, HU, IE, IT, LU, MC, NL, PL, PT, RO, SE, SI, SK, TR), OAPI (BF, BJ, CF, CG, CI, CM, GA, GN, GQ, GW, ML, MR, NE, SN, TD, TG).

[Continued on next page]

(54) Title: RFID TAGS AND PROCESSES FOR PRODUCING RFID TAGS

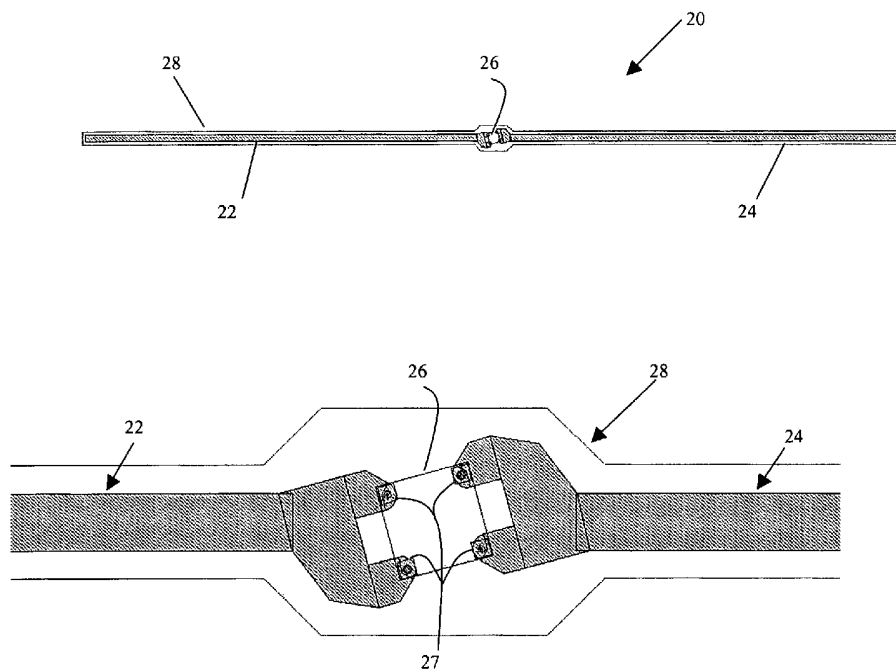

(57) Abstract: A Radio Frequency Identification (RFID) tag. The RFID tag comprises a flexible substrate and an integrated circuit embedded within the flexible substrate. The top surface of the integrated circuit is coplanar with the flexible substrate. At least one conductive element is formed on the flexible substrate. The conductive element is electrically connected to the integrated circuit. The conductive element serves as an antenna for the RFID tag.

WO 2004/086289 A2



Published:

— *without international search report and to be republished upon receipt of that report*

For two-letter codes and other abbreviations, refer to the "Guidance Notes on Codes and Abbreviations" appearing at the beginning of each regular issue of the PCT Gazette.

RFID TAGS AND PROCESSES FOR PRODUCING RFID TAGS

GOVERNMENT RIGHT NOTICE

[0001] This invention was made with government support under North Dakota State University Subcontract SB004-03, Defense Microelectronics Activity (DMEA) Sponsor Cooperative Agreement No. 90-03-2-0303 (prime). The government has certain rights to this invention.

RELATED APPLICATIONS

[0002] This application is related to and claims the benefit of U.S. Provisional Patent application serial number 60/457,263 filed March 24, 2003, which is hereby incorporated by reference in its entirety.

BACKGROUND

1). Field

[0003] Embodiments of the present invention relate generally to the Radio Frequency Identification (RFID) devices or tags and methods of making RFID devices or tags.

2). Description of the Related Art

[0004] Radio frequency identification (RFID) tags allow for the remote identification of objects through the use of radio waves.

[0005] Certain embodiments of the present inventions described here are aimed at improving the present state of RFID technology by lowering assembly cost, by providing new and useful form factors, or by enabling new applications of RFID. While the designs and processes described here can be used to form many types of electronic assemblies (e.g. sensors or arrays for antennas or other devices which are not RFID tags), they are particularly useful for RFID tags, where cost, size, and form factor are desirable elements.

[0006] Demands for RFID tags are expanding into many applications from small merchandises to large merchandises. It is desirable to have the RFID tags be made as small as possible and as flexible as possible to enable the effective incorporation of the RFID tags into various merchandises. Also, it is desirable to have the RFID tags to be made as least expensive as possible to allow for wide integration of the RFID tags to into various merchandises.

SUMMARY

[0007] The exemplary embodiments of the present invention pertain to a Radio Frequency Identification (RFID) tag. The RFID tag comprises a flexible substrate and an integrated circuit embedded within the flexible substrate. The top surface of the integrated circuit is coplanar with the flexible substrate. At least one conductive element is formed on the flexible substrate. The conductive element is electrically connected to the integrated circuit. The conductive element serves as an antenna for the RFID tag.

[0008] According to an aspect of the invention, an RFID tag comprises a flexible substrate and an integrated circuit embedded within the flexible substrate. The top surface of the integrated circuit is coplanar with the flexible substrate. The integrated circuit is embedded within the flexible substrate using a fluidic self assembly (FSA) process. A planarization layer is formed over the flexible substrate and the integrated circuit. At least one conductive element is formed on the flexible substrate and is electrically connected to the integrated circuit through at least one via created in the planarization layer. The conductive element serves as an antenna for the RFID tag.

[0009] According to another aspect of the invention, an RFID tag comprises a flexible substrate and an integrated circuit embedded within the flexible substrate. The integrated circuit has a top surface that is coplanar with the flexible substrate. The conductive elements are formed on the flexible substrate and electrically connected to the integrated circuit. The conductive elements also serve as an antenna for the RFID tag. The conductive elements are formed on a top surface and bottom surface of the substrate. An electrical connection is provided to connect the conductive element on the bottom surface

to the integrated circuit.

[0010] According to another aspect of the invention, an RFID tag comprises an RFID integrated circuit deposited in a flexible substrate. A first antenna layer is coupled to the RFID integrated circuit. A second antenna layer is coupled to the RFID integrated circuit. The first antenna layer is above the RFID integrated circuit and the second antenna layer is below the RFID integrated circuit. The RFID integrated circuit is coupled to the first antenna layer at the top of the RFID integrated circuit. The RFID integrated circuit is coupled to the second antenna layer at the bottom of the RFID integrated circuit.

[0011] Another aspect of the invention pertains to a method of assembling blocks where alignment is not critical. The method includes combining blocks, each containing a functional component, with a fluid to form a slurry. The slurry is then dispensed over a substrate having receptor holes, each of which is designed to receive one of the blocks. The relative size of each hole and block is such that each block is not axially aligned relative to a perimeter of the receptor holes. Each block is configured to include a bottom contact pad and a top contact pad that allow the functional component of the block to interconnect to conductive elements formed on the substrate even when each block is not axially aligned relative to the perimeter of the receptor holes.

[0012] In other aspects, methods of making exemplary embodiments of the RFID tags of the present invention are also described.

BRIEF DESCRIPTION OF THE DRAWINGS

[0013] Embodiments of the present invention are illustrated by way of examples and not limitations in the figures of the accompanying drawings, in which like references indicate similar elements and in which:

[0014] **Figures 1-2** compare actual sizes of exemplary RFID filaments or threads made in accordance to embodiments of the present invention to a U.S. dime;

[0015] **Figures 3-4** illustrate in details an exemplary embodiment of an RFID tag having the form of a thread or filament;

[0016] **Figures 5A-5C** illustrate more examples of an RFID tag having a filament

structure using NanoBlock™ ICs as integrated circuit (NanoBlock™ is a trademark of Alien Technology, Inc.);

[0017] **Figure 6** illustrates a densely-packed array of filament RFID tags formed on a flexible or plastic sheet;

[0018] **Figure 7** illustrates an exemplary embodiment of an RFID tag;

[0019] **Figure 8** illustrates another exemplary embodiment of an RFID tag;

[0020] **Figures 9A-9B** illustrate an exemplary embodiment of an RFID tag with top and bottom conductors forming an inductive loop;

[0021] **Figure 10** illustrates exemplary dimensions of an RFID tag made in accordance to embodiments of the present invention;

[0022] **Figure 11** illustrates an exemplary embodiment of an RFID tag that does not require precise alignment and orientation when being deposited into a substrate;

[0023] **Figure 12** illustrates an exemplary embodiment of assembling RFID tags in accordance to some embodiment of the present invention;

[0024] **Figures 13A-13B** illustrate another exemplary embodiment of assembling RFID tags in accordance to some embodiment of the present invention;

[0025] **Figures 14A-14B** illustrate an exemplary embodiment of assembling RFID tags wherein an FSA process is used to assemble the NanoBlock™ devices 110 into the holes in the substrate assembly;

[0026] **Figure 15** illustrates an exemplary embodiment of an RFID tag formed on a substrate and exemplary locations where the RFID tag can be cut for singulation;

[0027] **Figure 16** illustrates a cross-sectional side view of singulated RFID tag;

[0028] **Figure 17** illustrates exemplary cutting patterns for singulating RFID tags formed on a substrate;

[0029] **Figure 18** illustrates a top-view and a cross-sectional view of a singulated RFID tag; and

[0030] **Figure 19** illustrates an RFID tag assembly that includes an inductor.

DETAILED DESCRIPTION

[0031] In the following description, for purposes of explanation, numerous specific details are set forth in order to provide a thorough understanding of the present invention. It will be evident, however, to one skilled in the art that the present invention may be practiced without these specific details. In other instances, specific apparatus structures and methods have not been described so as not to obscure the present invention. The following description and drawings are illustrative of the invention and are not to be construed as limiting the invention.

[0032] In one embodiment we describe a form factor for RFID tags, in which the RFID tag is in the form of a thin, flexible strip, reminiscent of a filament 10 or a thread 20. Throughout the document, the RFID devices in the form of such thin, flexible strip, filament, thread, or other suitable structures are referred to as "RFID tags." These RFID tags can be quite small (**Figures 1 and 2**). **Figures 1 and 2** show photographic examples of electronic assemblies for RFID applications comparing the filament 10 and thread 20 of RFID to a U.S. dime. **Figures 3 and 4** illustrate that in one embodiment, an RFID tag 20 comprises a flexible substrate 28 (in one embodiment, a plastic film), an integrated circuit 26 embedded within the flexible substrate 28, and two conductive films 22 and 24 formed on top of the flexible or plastic substrate 28. The conductive films 22 and 24 are in electrical connection to the integrated circuit 26 that serve as antennas.

[0033] **Figure 4** shows a close up portion of the RFID tag 20 shown in **Figure 3**. In one embodiment, the RFID tag 20 includes a plurality of bonding pads 27 (or electrical connections) located on the integrated circuit (IC) 26. The bonding pads can be placed around the center or the edges of the integrated circuit 26, or at convenient locations on the integrated circuit. In one embodiment, the two conductive films 22 and 24 are connected to the integrated circuit 26 on opposite corners or in diagonal corners of the IC 26.

[0034] **Figures 5A-5C** illustrate more examples of an RFID tag having a filament structure using a NanoBlock™ IC as an integrated circuit. NanoBlock™ is a trademark of Alien Technology Inc. For clarity purpose, the printed conductors are not shown. **Figures 5B-5C** show the top and bottom view of the RFID tag.

[0035] In one embodiment, a fluidic self assembly (FSA) process is used to form

densely-packed array of filament tags on a flexible or plastic sheet. FSA is a process where a plurality of integrated circuit devices (such as NanoBlock™ ICs) are dispensed in a slurry. The slurry with the integrated circuits is dispensed over a substrate configured with receptors for the integrated circuits to be deposited therein. An example of this is shown in **Figure 6**. See U.S. Patent No. 5,545,291 for a description of an FSA process. Each integrated circuit can be a NanoBlock™ IC, which may be formed in the manner described in U.S. Patent Publication No. 2002/0127864-A1 and then placed into or on a receptor using an FSA process.

[0036] **Figure 6** is an illustration of one exemplary embodiment of a densely-packed array of filament tags on a substrate such as a plastic sheet 60. Other substrate types (other than plastic) can also be used. The substrate can have a form of a web substrate and is flexible. Each filament tag can later be singulated to form an RFID tag. RFID integrated circuits 62 are deposited in the plastic sheet 60 by FSA. Conductive traces 64 are printed on at least one surface of the sheet to form antennas on the plastic sheet 60. The conductive traces 64 that form the antennas are connected to the RFID integrated circuit 62. The filament tags can then be singulated to form individual RFID tags. An enlarged view 61 shows an array of unsingulated filament tags on the plastic sheet 60, where the array includes multiple RFID ICs 62 (deposited, through an FSA process, along lines formed by receptor locations on the plastic sheet which receive the RFID ICs) which are coupled to multiple conductive traces 64.

[0037] In one embodiment, a singulation process is used to separate the array of tags into individual RFID tags; in one exemplary embodiment, the singulation process may be performed by mechanical cutting, sawing, punching, laser ablating, hot-blade knife cutting or other techniques. After the singulation process is completed, an individual RFID tag may look like the RFID tag 20 shown in **Figure 3**. Exemplary dimensions of these tags produced from the plastic sheet 60 are described below and shown also in **Figure 10**. It can be seen from **Figure 6** that there are subarrays of RFID tags which are separated from each other by saw-tooth shaped gaps 63. It can also be seen that the ICs 62 are deposited in lines which are parallel to the edges of the plastic sheet 60 which may be, in one exemplary embodiment, processed as a web material in a roll to roll web

process, such as a type of process which is used to make paper. In one embodiment, the printed conductive traces 64, which are used to form the antenna elements for each tag, are formed at an oblique angle relative to the edges of the plastic sheet 60. In the case of **Figure 6**, each conductive trace forms an angle of about 10° . This arrangement tends to optimize (e.g. maximize) the amount of filament RFID tags which can be fabricated in a given area of the plastic sheet 60. It will be appreciated that different layouts (such as angle of the trace relative to the edge of the web material (which will engage the rolls at the beginning and end of the process)) may be optimal for RFID tags of different lengths and widths. As shown in **Figure 6**, the ends of one group of subarrays, such as the group of subarrays 65, interdigitate or interlace with the ends of an adjacent group of subarrays 66; this additional layout arrangement also tends to maximize the amount of filament RFID tags (or other types of devices) which can be fabricated in a given area of the plastic sheet. The ends of each conductive trace are adjacent to the gaps 63.

[0038] To maintain flexibility, in one embodiment, the substrate containing the integrated circuit is made of plastic. The substrate can be made of other flexible materials as well. In one embodiment, the thickness of the substrate is less than 1 mm, preferably less than 250 microns, and most preferably less than 125 microns. In one embodiment, the width of the filament RFID tag is less than 5 mm, more preferably less than 3 mm, and could be less than 1 mm. The length of the RFID tag and the antenna formed on the RFID tag substrate can vary but should be at least 5 mm long, more preferably 10 mm long, and could even be as long as 100 mm. Thus, an RFID tag having this form factor will be long in length, thin in thickness and narrow in width. Figure 10 shows an example of the dimensions of the RFID tag filament relative to an IC, such as an RFID IC.

[0039] It is to be appreciated that although fluidic self assembly processes are one desirable way of forming these RFID tag assemblies, other approaches can be used to place integrated circuits on these threads and filaments.

[0040] It is clear that such a thin, small, and flexible form factor for RFID enables several novel applications. In one embodiment, the RFID tag assembly is bonded to a nonconductive thread, and then woven into a fabric. The RFID tag can be embedded in

paper, with the flexible substrate of the RFID tag allowing the paper to remain flexible. The RFID tag can be adhered to an adhesive material to allow it to attach to another item (e.g., clothing or other merchandise).

[0041] Since the RFID tag is small, it can be hidden from view if desired. The RFID tag could be hidden underneath an opaque surface. Alternatively, the RFID tag can be colored black to make it difficult to see, or colored in a way as to blend in with its surroundings. For instance, the RFID tag can be made black or be colored in such a way that makes the RFID tag matches the material that the RFID tag is incorporated into. Further, a laminate may be applied over the top surface (and/or the bottom surface) to protect the RFID tag from being cut out from the object into which it is embedded.

[0042] Alternatively, in some applications it might be desirable to make the presence of the RFID filament tag very obvious or easy. The RFID tag could be colored or metalized to stand out against its background in these applications. Thus, the RFID tag could have a distinct appearance that serves a purpose of authenticating the presences of the RFID tag.

[0043] The RFID tags can be used to authenticate or identify paper-based products, including currency, legal documents (e.g. a passport or a visa) or other valuable items. The thin size and flexibility characteristics of the RFID tag make it possible to integrate the RFID tag into a label or tape, which can then be attached to an item to provide RFID tag capability. The RFID tag can also be used to authenticate or identify non-paper items as well. For instance, the RFID tag's thin profile and small size make it easier to provide RFID tag capability to small, valuable items such as pharmaceuticals or electronic components. Such a tag could be embedded within a container (such as embedded in a plastic container), or actually mixed in with the contents of a container.

[0044] In one embodiment, the RFID tag is deployed (or incorporated) or configured to deploy into another item in a way that the RFID tag spans into a three dimensional structure, e.g., an RFID thread bent into a curved RFID filament or thread or an RFID thread shaped or bent into a wrinkled RFID thread or otherwise an RFID tag shaped in a three dimensional structure. There are a variety of ways of constructing an RFID tag to include of integrated circuits, flexible polymers, flexible substrate, and conductive traces.

Following are some illustrative examples. While these structures can be used for narrow filament tags, it should also be recognized that more conventional RFID tag structures can also be built using these structures.

[0045] **Figure 7** shows, in a cross-sectional view, one construction of an RFID tag. An RFID tag shown in **Figure 7** can be one of the RFID tag shown in **Figure 6**. In one exemplary method for forming this structure, an integrated circuit 71 is deposited in a receptor hole 73 in the base film (a flexible or plastic substrate 75) using an FSA process. In one embodiment, the integrated circuit 71 is positioned or deposited such that it is coplanar with the flexible substrate 75. In one embodiment, coplanar refers to a configuration where the integrated circuit 71 is deposited in the substrate 75 such that a surface of the integrated circuit 71 is flushed with a surface of the substrate 75. In one embodiment, coplanar refers to a configuration where the integrated circuit 71 is deposited in the substrate 75 such that a surface of the integrated circuit 71 is below a surface of the substrate 75. In one embodiment, coplanar refers to a configuration where the integrated circuit 71 is deposited in the substrate 75 such that a top surface of the integrated circuit 71 shares essentially the same plane as the top surface of the substrate 75.

[0046] Still with **Figure 7**, a planarization layer 77 is formed on top of the substrate 75 and integrated circuit 71. Via holes 72 are formed in the planarization layer to expose the contact pads (not shown) on the integrated circuit 71. A metal interconnection 79 (or metal traces) is then made to both provide a connection to the pads on the integrated circuit as well as to form antennas for the RFID tag. While photolithographic methods can be used to form the metal traces it is also possible to simply print conductive inks on the substrate 75 to form the antennas. This printing operation simultaneously forms an electrical connection to the integrated circuit 71 and forms the antenna elements. The RFID tag shown in **Figure 7** may be similar to the tag 20 shown in **Figure 3**. It is to be noted that the RFID tag shown in **Figure 7** is not drawn to scale.

[0047] Additionally, while it is possible to print specific antenna traces, it is also possible to blanket coat a nearly-continuous film of conductor on top of the planarization layer, leaving only the center portion of the integrated circuit exposed. When the filament

tags are cut out from the sheet, the simple act of separating the filaments will form the antennas. In one embodiment, a subtractive method is used to form the antenna traces on the planarization layer. The subtractive method includes techniques such as chemical etching, laser ablation, and mechanical removal in which a continuous layer is first applied and then portions are etched away by chemical etching, laser ablation, or mechanical removal to create an appropriate pattern.

[0048] In one embodiment, as shown in **Figure 8**, an RFID tag is formed without a planarization layer. In **Figure 8**, an integrated circuit 85 is deposited in a receptor hole 73 in a substrate 83 (using an FSA process in one embodiment). A metal interconnection 81 is formed directly on the top surface of the substrate 83. Of course, it is possible to subsequently attach other materials to the top or bottom surface of the RFID tags shown in **Figure 7** or **Figure 8**. No planarization layer is used in the RFID tag shown in **Figure 8**. The metal interconnection 81 can be formed as a substantially continuous film over the substrate 83 and the integrated circuit 85. An area (e.g., approximately in the center portion) on the integrated circuit 85 is left exposed.

[0049] **Figure 9A** shows, in a cross-sectional view, another structure for an RFID filament (thread) tags, in which via holes 91 formed through a substrate 90 (e.g. a plastic substrate) provide access for electrical connection between a conductor 92 (e.g. an antenna element) formed on a top surface of the substrate 90 to a conductor 93 (e.g., an antenna element) formed on the bottom surface of the substrate 90. Such an RFID tag architecture will enable the antenna to form an inductive loop structure, which can be a valuable design feature in certain embodiments for maximizing the performance of certain RFID tags. In one embodiment, the substrate 90 includes an integrated circuit 94 which can be a NanoBlock™ IC.

[0050] While **Figure 9A** does not show the presence of a top planarization layer, it should be recognized that it is possible to form an equivalent structure with a planarization layer as shown in **Figure 7** with via holes in the planarization layer and in the substrate to allow for electrical connection between the conductor on a top surface and a conductor on a bottom surface.

[0051] **Figure 9B** shows a top view of the RFID tag of **Figure 9A**. The IC 94 is shown

electrically connected to the conductors 92 formed on the top surface of the substrate 90 and to the conductor 93 formed on the bottom surface of the substrate 90. The conductors 92 and 93 may be printed on the substrate 90 or may be formed by other methods. In the example shown in **Figure 9B**, the conductors 92 do not cover the entire top surface of the substrate 90, and these conductors have been shown, for purposes of illustration, as transparent objects even though they may not be transparent. The conductor 93 may or may not cover the entire bottom surface of the substrate 90 and may or may not be transparent. The via holes 91 are shown adjacent the ends of the two top conductors 92. The IC 94 is coupled electrically to the conductors 92 through two bonding pads 94A and 94B on the IC 94. In one exemplary embodiment of a process to make the RFID tag shown in **Figures 9A and 9B**, the via holes 91 may be created with laser ablation which drills through the plastic substrate. In an alternative embodiment, rather than using the via holes 91 to electrically connect a top conductor to a bottom conductor, the top and bottom conductors may be electrically connected around the edges of the flexible substrate. One way of providing such a connection is by coating or dipping the ends (or certain other portions which will not short circuit the IC) of the thread in a conductive ink. In certain embodiments of the RFID tag shown in **Figures 9A and 9B**, the electrical connection between the top and bottom conductors can help prevent against damage to the IC 94 in the thread from electrostatic discharge and can also help to cancel reactance from the IC 94. In one embodiment, the RFID tag in **Figure 9A**, has the contact to the bottom conductor (through the via holes) configured or is used to match the impedance of the antenna elements and the RFID IC 94.

[0052] **Figure 10** shows some illustrative dimensions for a filament RFID tag where the substrate which holds an IC 101 of the RFID tag is not shown. In one embodiment, the substrate may be only minimally wider than the antenna elements 104 and 105. The antenna elements 104 and 105 are shown electrically coupled to the IC 101 through bonding pads 106 and 107.

[0053] It can be seen from **Figure 10** and its accompanying description that the width of the RFID tag may be equal to or slightly greater than the IC 101 (e.g. an RFID IC or a NanoBlock™ IC) contained within the RFID tag. In the case of **Figure 10**, the substrate

may be slightly wider (e.g. about 0.10 mm or 0.20 mm wider) than the IC 101 or it may be substantially equal in width to the width of the IC 101. Further, the length of the RFID tag may be at least 10 times the length of the IC 101 and more preferably may be at least 30 times the length of the IC 101 and could even be over 100 times the length of the IC 101. The length of the RFID tag may, in one embodiment, be optimized to cancel the electrical reactance of the RFID IC 101 in the RFID tag. Further, the structure of the antenna elements 104 and 105 may be designed to substantially or approximately match the impedance of the antenna elements to the input impedance of the RFID IC 101.

[0054] Exemplary RFID tags of the present invention can be formed from integrated circuits comprising two interconnection pads or more than two interconnection pads. For example, RFID tags with three interconnection pads on the integrated circuit and RFID tags with four interconnection pads on the integrated circuit can be used. In some embodiments one interconnection pad serves as a local ground connection (which can still be attached to an antenna), one or more interconnection pads serve as an additional antenna connection, and one or more pads can be connected to an external capacitor or other electrical element to enhance the RFID tag performance. It should be recognized that designs with 3 or 4 integrated circuit connection pads can be used in the designs and applications described herein.

[0055] In some embodiments, an RFID IC may be created as a NanoBlock™ IC (e.g. using processes described in U.S. Patent Publication No. 2002/0127864-A1) or as a conventional IC (e.g. without the wedge-shaped sides of embodiments of a NanoBlock™ IC).

[0056] **Figure 11** illustrates an exemplary embodiment where an RFID IC can be assembled into a substrate where proper alignment or orientation of the RFID IC to be deposited into a receptor in the substrate is more relaxed or less stringent. As shown in **Figure 11**, an RFID IC 110 is placed into a receptor 109 which includes a conductive element 117 that serves as an antenna element. The conductive element 117 is thus located below the RFID IC 110. This conductive element 117 may be referred to as a bottom antenna and it is electrically coupled (resistively or capacitively) to the IC 110. The RFID IC 110 is also electrically coupled (resistively or capacitively) to a conductive

element 107 which is above the RFID IC, and the conductive element 107 may be referred to as a top antenna. In one embodiment, the RFID IC 110 is electrically coupled to the top antenna through a contact 116 provided on a top surface of the RFID IC 110 and is electrically coupled to the bottom antenna through a contact 115 provided on a bottom surface of the RFID IC 110.

[0057] The IC bonding pads 137 and 136 on a top surface 114 of the IC 110 make electrical contact, respectively, with a bottom contact 115 and a topside contact 116. In one embodiment, as shown in **Figure 11**, the bottom contact 115 electrically connects with the bonding pad 137 and is wrapped around a side of the IC 110 (which resembles a block) and continues on the bottom side of the IC 110. In one embodiment, the IC 110 is shown as having a wedge-shaped side but it will be appreciated that a rectangular-shaped side may also be used in certain embodiments.

[0058] In one embodiment of this RFID tag, the size of the top contact 116 on a top surface of the RFID IC is significantly larger than a bonding pad 136 on the top of the RFID IC 110, and the size of the bottom contact 115 on the bottom surface of the RFID IC is significantly larger than another bonding pad 137 on the top of the RFID IC 110. In this embodiment, the size of the top contact 116 is about the same size as the entire top surface of the RFID IC 110, and the size of the bottom contact 115 is about the same size as the entire bottom surface of the RFID IC 110. In one embodiment, the RFID IC 110 includes an interconnect 115a which extends from a bonding pad 137 on the top of the IC 110, around a side of the IC 110 to the bottom of the IC 110, and the bottom portion of this interconnect 115a may be the bottom contact 115. In one embodiment, the RFID tag may include a planarization layer or a dielectric layer (not shown) formed on top of the spacer layer 120 and the IC 110 similar to the RFID tag shown in **Figure 7**.

[0059] The RFID IC 110 is supported, in one embodiment, within a spacer layer 120 which is coupled to the top antenna 107 and to the bottom antenna 117. The receptor or opening 109 in the spacer layer 120 is considerably larger than the size of the RFID IC 110. This opening 109 is not designed to relatively precisely match the size of the block of the RFID IC 110. Rather, the RFID IC 110 fits in the opening 109 without aligning to the perimeter of the opening 109. In one exemplary embodiment the opening is at least

50% larger in area than the area of the bottom surface (or area of the top surface) of the block of the RFID IC 110. Further, the geometry of the opening 109 does not need to match the geometry of the RFID IC 110; for example, the opening 109 may have a circular geometry and the RFID IC 110 may have a rectangular (e.g., square) geometry. Even though an FSA process may be used to place the RFID ICs 110 into the openings 109, the RFID ICs 110 do not need to be aligned to the perimeter of the opening 109. Thus, after an FSA process, the RFID ICs 110 may have different rotational orientations within the openings 109. The RFID ICs 110 in this embodiment are designed to operate properly whether they are oriented up or down (relative to the layer of circuitry in the RFID IC 110) because there is only one electrical contact on a top surface of the RFID IC 110 (contact 116) and only one electrical contact on a bottom surface of the RFID IC 110 (contact 115). Since these contacts cover a large portion of both surfaces (top and bottom) of the RFID IC 110 and since there are no other electrical contacts on these surfaces, it is possible to deposit the RFID ICs 110 into the openings 109 without aligning them in the openings 109 and without needing to align small bonding pads on the RFID ICs 110 to interconnects on the top and bottom antennas. The embodiments discussed may be used for thread tags or non-thread tags. These embodiments allows an FSA process in which blocks, each containing a functional element (e.g. an RFID IC), are mixed in a fluid to form a slurry and then the slurry is deposited onto a substrate having openings wherein the openings are substantially larger and/or having different shapes than the blocks and/or the perimeters of the blocks are not aligned with the perimeters of the openings after the FSA process is completed.

[0060] Exemplary methods for fabricating RFID thread tags are detailed starting from pre-formed, two-terminal, RFID NanoBlock™ devices that have one electrical contact 116 located on the topside of the device and the other electrical contact 115 located on the bottom of the device. The methods are amenable to implementation as a web based manufacturing process.

[0061] First, an RFID NanoBlock™ device 110 with top and bottom electrical contacts 115 and 116 as shown in **Figure 11** is provided. The electrical contacts 115 and 116 may be formed from, or include a full or partial layer of, a conducting adhesive material, such

as a silver-particle loaded thermal plastic or b-staged epoxy, low temperature solder, cold-weldable material such as gold, etc. Alternatively, the electrical contacts 115 and 116 may be covered by a thin layer of a non-conducting adhesive material, such as a PSA, hot-melt adhesive, etc, or non-conducting b-staged epoxy (in order to form, in one embodiment, a capacitive contact).

[0062] Next, the RFID NanoBlock™ device 110 is deposited in a substrate to form an RFID tag. In one embodiment, the RFID tag is formed on a web-base material or substrate and then singulated into an individual RFID tag. Thus, a plurality of RFID tags can be formed on one substrate. **Figure 12** illustrates an exemplary embodiment of assembling RFID tags in accordance to some embodiment of the present invention. In one embodiment, an FSA process is used to assemble a plurality of RFID ICs into the substrate of the RFID tags. The spacer layer 120 is adhered to a substrate that is a web-based material. In **Figure 12**, a substrate 129 having one or more strips of a NanoBlock™ spacer layer 120 in which NanoBlock™ device receptor site holes 121 have been formed is provided. The substrate 129 may have a form of a web substrate as shown in **Figure 12**. The cut-off end of the web substrate is to indicate that what is shown in the figure is a section from a long web (processed in a roll to roll web process, such as a paper making process).

[0063] As shown in **Figure 12**, the holes 121 have a circular shape. These circular holes 121 can be fabricated by punching, embossing, drilling, laser cutting or ablation, etc. The holes 121 may have alternative geometries such as rectangular or square holes or have other regular shapes or even be irregularly shaped. To facilitate assembly, the spacer layer 120 may be coated on its front and/or back side with an adhesive material, such as a PSA, hot-melt adhesive, etc, or non-conducting b-staged epoxy or a UV-curable polymeric material (not shown). The thickness of this spacer layer 120 and the size of the holes 121 are made such that no more than one NanoBlock™ device 110 will remain in each hole 121 after completion of the FSA process.

[0064] As way of an example, in one embodiment in which the NanoBlock™ devices 110 are nominally square (as viewed from the top) and the holes 121 in the spacer layer 120 are round, the spacer layer 120 thickness would be selected to be approximately

equal to the thickness of the NanoBlock™ devices 110, and the hole diameter 121 could be in the range of 1.41 to 1.8 times the nominal NanoBlock™ device 110 width.

[0065] Next, in one embodiment, a bottom-antenna layer 130 is attached to the spacer layer 120 as illustrated in **Figures 13A-13B**. In one embodiment, the bottom-antenna-layer 130 is fabricated of a conducting material or is a layered structure that includes a conducting layer 131. **Figures 13A-13B** show top and end-on views, respectively, of the bottom-antenna layer 130. To facilitate assembly, areas of one or both sides on the bottom-antenna-layer 130 may be coated with an electrically conductive adhesive material (or non-conductive adhesive material in the case of a capacitive contact). In one embodiment, the electrically conductive (or non-conductive) adhesive material can be applied by lamination or screen printing (or other suitable techniques) to the bottom-antenna-layer 130. In addition, some areas, including those that will contact either the top or bottom contacts of the NanoBlock™ devices 110, may be coated with an electrically conductive adhesive such as the conducting adhesive strips 132 shown in **Figure 13A and 13B** (or a thin layer of a non-conducting adhesive in the case of a capacitive contact).

[0066] In one embodiment, the spacer layer 120 (or a plurality of spacer layer strips 120) is attached to the bottom-antenna layer 130 by static pressure, lamination, etc., where one or more of the adhesive layers 132 discussed above bonds the pieces together. In one embodiment, the spacer layer 120 and the bottom-antenna layer 130 forms the substrate 129 for the RFID tag.

[0067] In one embodiment, an FSA process is used to assemble the NanoBlock™ devices 110 into the holes 121 in the substrate assembly. (See **Figures 14A and 14B**). The ICs (such as NanoBlock™ devices 110) are mixed with a fluid to form a slurry and the slurry is dispensed over a substrate (such as bottom antenna layer 130 with layer 120), causing at least some of the ICs, shaped as blocks, to fall into and remain in the holes (e.g. holes 121) in the spacer layer 120. **Figures 14A and 14B** show the result of an FSA process (or an alternative process) which was used to create the structure shown in these **Figures 14A and 14B**. Note that the ICs 110 are not axially aligned and are not rotationally aligned relative to their respective holes 121; thus, relative to the edge 133,

the ICs 110 have different rotational orientations and they also have, relative to their respective hole 121, different axial positions within their respective hole 121 (e.g. some are positioned to the left of center, some are positioned to the right of center, etc.).

[0068] Depending on the location and type of adhesive materials employed, the NanoBlock™ devices 110, if desired, might now be attached to the substrate assembly by a hot-roll lamination process. In one embodiment, the spacer layer 132 is semi-transparent. The substrate assembly includes (as shown in **Figure 14A**) three strips of spacer layers 120 laminated onto a bottom antenna layer 130. It is to be expected that more or less than three spacer layers 132 maybe included. In one embodiment, each strip of spacer layer 120 is aligned over one of the conducting adhesive strips 132 which are adhered onto the bottom-antenna-layer 130.

[0069] **Figure 14B** shows a close-up cross-section of a NanoBlock™ device 110 in a receptor site (hole 121) formed by an assembly of a strip of spacer layer (e.g. spacer layer 120) and the bottom-antenna-layer (e.g. layer 130). In one embodiment, individual spacer layer strips 120 are laminated over individual conducting adhesive strip 132 which is adhered on the bottom-antenna-layer 130. Alternatively, the spacer layer strips 120 are laminated over one continuous adhesive strip 132. As noted in **Figure 12**, the adhesive layers 132 on the top and bottom of the spacer layer strip 120 are employed to hold the assembly together, and the NanoBlock™ device 110 is held in place by a portion of the conducting adhesive strip 132 originally part of the bottom-antenna-layer 130.

[0070] Next, as shown in **Figure 15**, in one embodiment, a top-antenna layer 135 is laminated over the spacer layer 120 that has the RFID IC 110 deposited therein. In one embodiment, the top-antenna-layer 135 is fabricated of a conducting material or is a layered structure that includes a conducting layer 136 and has a structure, in one embodiment, which is similar to or the same as the structure of the bottom antenna layer 130. In one exemplary embodiment, the top antenna layer 135 includes a conducting layer 136, which may be supported on a plastic substrate (not shown) and conductive adhesive strips 132 adhered to the conducting layer 136. The conductive adhesive strips 132 on the top antenna layer may be arranged in the same pattern as in the case of the bottom antenna layer (see, e.g. **Figure 14A**). With the presence of an adhesive layer that

is conductive as the conductive adhesive strips 132, the conducting layer 136 may be eliminated.

[0071] In another embodiment, areas of one or both sides on the top-antenna-layer 135 may be coated with an electrically conductive or non-conductive adhesive material. In addition, some areas, including those that will contact either the top or bottom contact pads of the NanoBlock™ devices 110, may be coated with an electrically conductive adhesive (e.g. conducting adhesive strips 132) or a thin layer of a non-conducting adhesive. In another embodiment, the top-antenna-layer 135 is laminated over the spacer layer 120 such that the conducting layer 136 makes electrical contact, resistive or capacitive, with any NanoBlock™ devices 110 present or deposited in the spacer layer 120.

[0072] In one embodiment, the RFID tags are formed on a web substrate. The web substrate includes one or more spacer layer 120 each of which having receptors 121 for the RFID ICs 110 to be deposited therein. After the RFID ICs 110 are deposited and various layers laminated or formed as previously described, each individual RFID tag can be singulated from the web substrate. The web substrate is cut (e.g., in a web length-wise manner in order to separate sheets of connected RFID tags. **Figure 15** illustrates two exemplary locations on the web substrate where an RFID tag formed can be singulated. **Figure 16** illustrates an end-on view of a sheet that has an RFID tag singulated from the web substrate. The cutting operation may be performed by mechanical cutting, sawing, punching, laser ablating, hot-blade knife cutting, gas-jet cutting, etc.

[0073] When formed in a web substrate format, at least the top-antenna-layer 135 and the bottom-antenna-layer 130 are in continuous or connected form on RFID tag assembly to another RFID tag assembly. **Figure 17** illustrates a semi-transparent top-view of a sheet of connected RFID tags. On the left of the sheet is shown a bottom-antenna-layer 130 and on the right of the sheet is shown a top-antenna-layer 135. A strip of spacer layer 120 having deposited therein a plurality of RFID IC 110 (e.g., NanoBlock™ devices) is shown to be attached to the bottom-antenna layer 130 and the top-antenna layer 135. Also shown in **Figure 17** are two examples of how the RFID tags formed on a

web substrate can be singulated. Two exemplary cutting patterns, cutting pattern A and cutting pattern B are illustrated in this figure. Each RFID tag can be cut along the dashed lines to be separated from the web substrate. After the RFID tags are formed as previously described, the RFID tags can be singulated. **Figure 18** illustrates semi-transparent top-view and side view of a singulated or separated RFID tag cut using the cutting pattern A. The cutting operation may be performed by mechanical cutting, sawing, punching, laser ablating, hot-blade knife cutting, gas-jet cutting, etc. Cuts can be made straight across the sheets or in more complicated patterns in order to affect electrical characteristics of the resulting antenna or physical or design characteristics of the tags. In one embodiment, holes may also be formed in the antenna layers to affect form, function, and utility.

[0074] An alternate tag assembly that includes an inductor in parallel with the NanoBlock™ device is shown in **Figure 19**. In one embodiment, the RFID tag includes one additional strip of conducting adhesive per spacer layer strip, applied to either the top or bottom antenna layer, and wide spacer layer strips. The inductor formed can improve tag electrical performance. **Figure 19** illustrates an end-on-view of an RFID tag in a sheet format.

[0075] The RFID tag includes a wide spacer layer 180, an additional strip of conducting adhesive 183, applied to either the top antenna layer 181 or bottom antenna-layer 182. The RFID tag assembly shown in **Figure 19** is similar to the tag assembly shown in **Figure 15** and includes the bottom antenna layer 181 (which has a conducting layer which serves as the bottom antenna and a conducting adhesive strip which electrically connects the bottom antenna to the bottom contact on the RFID IC 110) and the top antenna layer 182 (which has a conducting layer which serves as the top antenna and a conducting adhesive strip which electrically connects the top antenna to the top contact on the IC 110) and a wide spacer layer 180 which includes an opening to receive the RFID IC 110.

[0076] During the top-antenna-layer 182 lamination, the top antenna layer 181 and the bottom antenna layers 182 are electrically joined along the added conducting adhesive 183 strip. In the finished tag, the conduction path around the wide spacer layer 180

forms an inductor loop in parallel with the RFID IC 110 (e.g., a NanoBlock™ device), thus enhancing electrical performance in certain embodiments.

[0077] While certain exemplary embodiments have been described and shown in the accompanying drawings, it is to be understood that such embodiments are merely illustrative and not restrictive of the current invention, and that this invention is not restricted to the specific constructions and arrangements shown and described since modifications may occur to those ordinarily skilled in the art.

CLAIMS

1. A Radio Frequency Identification (RFID) tag comprising:
 - a flexible substrate;
 - an integrated circuit embedded within the flexible substrate, the top surface of the integrated circuit being coplanar with the flexible substrate;
 - at least one conductive element formed on the flexible substrate, the at least one conductive element being electrically connected to the integrated circuit, the conductive element serving as an antenna for the RFID tag.
2. The RFID tag of claim 1 wherein the at least one conductive element being electrically connected to the integrated circuit is done through an electrical connection that is capacitive in nature.
3. The RFID tag of claim 1 wherein the at least one conductive element being electrically connected to the integrated circuit is done through an electrical connection that is resistive in nature.
4. The RFID tag of claim 1 wherein integrated circuit comprises at least two interconnection pads.
5. The RFID tag of claim 1 wherein the conductive element comprise at least one of metal particles, organic particles, semiconducting particles.
6. The RFID tag of claim 1 wherein the conductive element is at least one of a printed conductive element, evaporated metal, sputtered metal, plated metal, and a laminated conducting foil.
7. The RFID tag of claim 1 wherein flexible substrate has a width that is one of slightly greater than or substantially equal to the width of the integrated circuit.

8. The RFID tag of claim 1 wherein the RFID tag includes two conductive elements formed on the substrate and wherein the two conductive elements are electrically connected to the integrated circuit on opposite corners or in diagonal corners of the integrated circuit.
9. An RFID tag comprising:
 - a flexible substrate;
 - an integrated circuit embedded within the flexible substrate, the top surface of the integrated circuit being coplanar with the flexible substrate, wherein the integrated circuit is embedded within the flexible substrate using a fluidic self assembly (FSA) process;
 - a planarization layer is formed over the flexible substrate and the integrated circuit
 - at least one conductive element formed on the flexible substrate, the at least one conductive element being electrically connected to the integrated circuit through at least one via created in the planarization layer, the conductive element serving as an antenna for the RFID tag.
10. The RFID tag of claim 8 wherein the at least one conductive element being electrically connected to the integrated circuit is done through an electrical connection that is capacitive in nature.
11. The RFID tag of claim 8 wherein the at least one conductive element being electrically connected to the integrated circuit is done through an electrical connection that is resistive in nature.
12. The RFID tag of claim 8 wherein integrated circuit comprises at least two interconnection pads.

13. The RFID tag of claim 8 wherein the conductive element comprise at least one of metal particles, organic particles, semiconducting particles.
14. The RFID tag of claim 8 wherein the conductive element is at least one of a printed conductive element, evaporated metal, sputtered metal, plated metal, and a laminated conducting foil.
15. The RFID tag of claim 8 wherein flexible substrate has a width that is one of slightly greater than or substantially equal to the width of the integrated circuit.
16. The RFID tag of claim 8 wherein the RFID tag includes two conductive elements formed on the substrate and wherein the two conductive elements are electrically connected to the integrated circuit on opposite corners or in diagonal corners of the integrated circuit.
17. The RFID tag of claim 8, wherein the RFID tag has a geometry or form factor of a thread tag.
18. The RFID tag of claim 8, wherein the RFID tag has a thickness less than or equal to about 1 mm, a width of less than or equal to about 3 mm, and a length of about 10 mm or greater.
19. The RFID tag of claim 8, wherein the RFID tag assembly is bonded to a nonconductive thread.
20. The RFID tag of claim 19 wherein the nonconductive thread is woven into a fabric.
21. The RFID tag of claim 19 wherein the nonconductive thread is embedded or woven within paper.

22. The RFID tag of claim 19 wherein the nonconductive thread has a distinct appearance that serves a purpose of authenticating the presence of the RFID tag.
23. The RFID tag of claim 19 wherein an adhesive material is used to attach the RFID tag assembly to another item.
24. The RFID tag of claim 19 wherein the RFID tag is deployed in a way that spans three dimensions.
25. The RFID tag of claim 19 wherein the RFID tag includes a visual appearance that makes it difficult to see the RFID tag.
26. The RFID tag of claim 19 wherein the RFID tag includes a visual appearance that makes it easy to see the RFID tag.
27. A method of forming an RFID tag comprising:
 - depositing an integrated circuit within a receptor in a flexible substrate using FSA;
 - forming at least one conductive trace on the flexible substrate to simultaneously form an electrical connection to the integrated circuit and form an antenna element.
28. The method of claim 27 wherein the integrated circuit is coplanar with the flexible substrate.
29. The method of claim 27 further comprises forming a planarization layer over the flexible substrate and the integrated circuit, wherein the electrical connection connected to the integrated circuit through at least one via created in the planarization layer.

30. The method of claim 27 wherein the at least one conductive trace being electrically connected to the integrated circuit is done through an electrical connection that is capacitive in nature.
31. The method of claim 27 wherein the at least one conductive trace being electrically connected to the integrated circuit is done through an electrical connection that is resistive in nature.
32. The method of claim 27 wherein the integrated circuit comprises at least two interconnection pads.
33. The method of claim 27 wherein the conductive trace comprise at least one of metal particles, organic particles, semiconducting particles.
34. The method of claim 27 wherein the conductive trace is at least one of a printed conductive element, evaporated metal, sputtered metal, plated metal, and a laminated conducting foil.
35. The method of claim 27 wherein flexible substrate has a width that is one of slightly greater than or substantially equal to the width of the integrated circuit.
36. The method of claim 27 wherein the RFID tag includes two conductive traces formed on the substrate and wherein the two conductive elements are electrically connected to the integrated circuit on opposite corners or in diagonal corners of the integrated circuit.
37. The method of claim 27 wherein the integrated circuit is a NanoBlock integrated circuit.

47. The method of claim 29 wherein the conductive trace is formed using at least one of screen printing, ink jet printing, and extrusion printing.
48. The method of claim 29 wherein the conductive trace is formed by a subtractive patterning method.
49. The method of claim 48 wherein the subtractive patterning method includes at least one chemical etching, laser ablation, and mechanical removal.
50. An RFID tag comprising:
a flexible substrate;
an integrated circuit embedded within the flexible substrate, the integrated circuit having a top surface that is coplanar with the flexible substrate;
conductive elements formed on the flexible substrate and electrically connected to the integrated circuit, the conductive elements also serving as an antenna for the RFID tag; and
wherein the conductive elements are formed on a top surface and bottom surface of the substrate, and wherein an electrical connection is provided to connect the conductive element on the bottom surface to the integrated circuit.
51. The RFID tag of claim 50 further comprises a planarization layer formed over the flexible substrate and the integrated circuit and wherein the electrical connection is formed through at least one via hole in the planarization layer.
52. The RFID tag of claim 50 wherein the electrical connection are formed by electrical connection around at least one side of the flexible substrate.

38. The method of claim 29 wherein the integrated circuit is a NanoBlock integrated circuit.
39. The method of claim 29 wherein the at least one conductive trace being electrically connected to the integrated circuit is done through an electrical connection that is capacitive in nature.
40. The method of claim 29 wherein the at least one conductive trace being electrically connected to the integrated circuit is done through an electrical connection that is resistive in nature.
41. The method of claim 29 wherein the integrated circuit comprises at least two interconnection pads.
42. The method of claim 29 wherein the conductive trace comprise at least one of metal particles, organic particles, semiconducting particles.
43. The method of claim 29 wherein the conductive trace is at least one of a printed conductive element, evaporated metal, sputtered metal, plated metal, and a laminated conducting foil.
44. The method of claim 29 wherein flexible substrate has a width that is one of slightly greater than or substantially equal to the width of the integrated circuit.
45. The method of claim 29 wherein the RFID tag includes two conductive traces formed on the substrate and wherein the two conductive traces are electrically connected to the integrated circuit on opposite corners or in diagonal corners of the integrated circuit.
46. The method of claim 29 wherein the planarization layer comprised of a polymer.

53. The RFID tag of claim 50 wherein the conductive elements formed on the top surface and on the bottom surface are connected through the electrical connection.
54. The RFID tag of claim 53 wherein the conductive elements formed on the top surface and on the bottom surface form electrical loops structures, or inductive elements for the RFID tag.
55. An RFID tag comprising:
- an RFID integrated circuit deposited in a flexible substrate;
 - a first antenna layer coupled to the RFID integrated circuit; and
 - a second antenna layer coupled to the RFID integrated circuit, wherein the first antenna layer is above the RFID integrated circuit and the second antenna layer is below the RFID integrated, wherein the RFID integrated circuit is coupled to the first antenna layer at the top of the RFID integrated circuit and the RFID integrated circuit is coupled to the second antenna layer at the bottom of the RFID integrated circuit.
56. A method of forming an RFID tag comprising:
- combining blocks, each containing a functional component, with a fluid to form a slurry;
 - dispensing the slurry over a substrate having receptor holes, each of which is designed to receive one of said blocks, wherein the relative size of each hole and block is such that each block is not axially aligned relative to a perimeter of the receptor holes; and
 - wherein each block is configured to include a bottom contact pad and a top contact pad that allow the functional component of the block to interconnect to conductive elements formed on the substrate even when each block is not axially aligned relative to the perimeter of the receptor holes.

57. The method of claim 56 wherein the blocks are deposited in the substrate so that they are coplanar with the substrate.
58. The method of claim 56 further comprises forming a planarization layer having vias created therein formed over the substrate and the blocks, the vias allowing for electrical connection to the functional components of the blocks.
59. The method of claim 58 wherein the conductive elements are capacitive in nature.
60. The method of claim 58 wherein the conductive elements are resistive in nature.
61. The method of claim 58 wherein the conductive elements are comprised at least one of metal particles, organic particles, and semiconducting particles.
62. The method of claim 58 wherein the conductive trace is at least one of a printed conductive element, evaporated metal, sputtered metal, plated metal, and a laminated conducting foil.
63. The method of claim 58 wherein each of the blocks is a NanoBlock integrated circuit.
64. The method of claim 58 wherein the conductive elements is at least one of printed conductive elements, evaporated metals, sputtered metals, plated metals, and a laminated conducting foils.
65. The method of claim 58 wherein the substrate has a width that is one of slightly greater than or substantially equal to the width of the blocks.
66. The method of claim 58 wherein the conductive element is formed using at least one of screen printing, ink jet printing, and extrusion printing.

67. The method of claim 58 wherein the conductive element is formed by a subtractive patterning method.
68. The method of claim 58 wherein the subtractive patterning method includes at least one chemical etching, laser ablation, and mechanical removal.

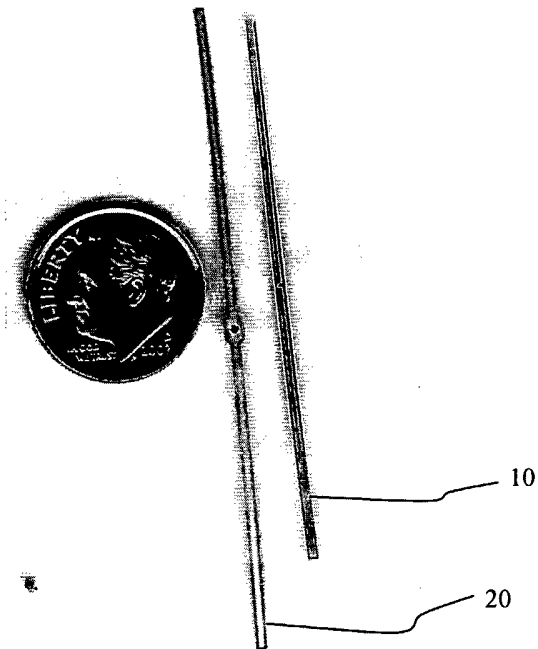

FIGURE 1

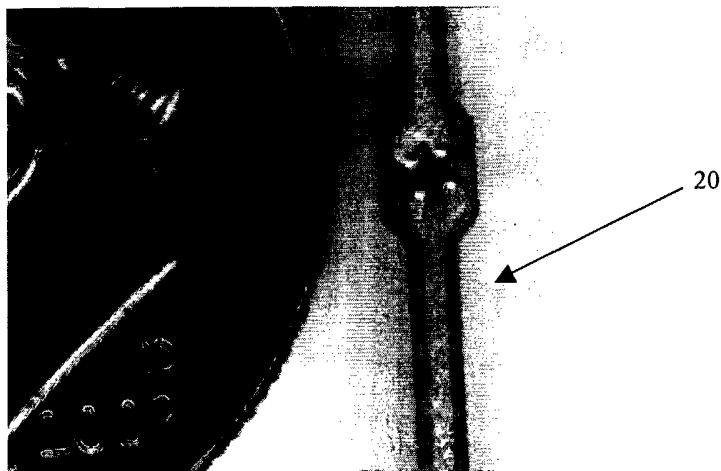

FIGURE 2

FIGURE 3

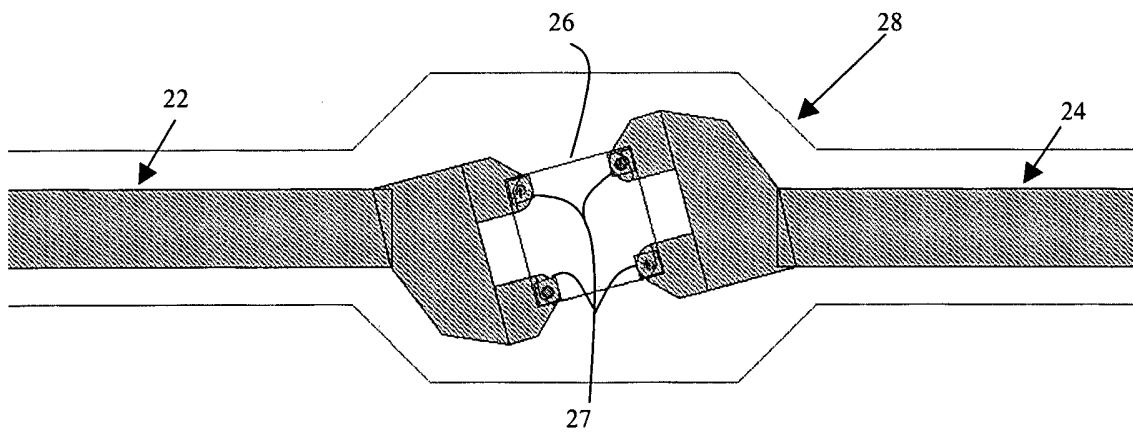
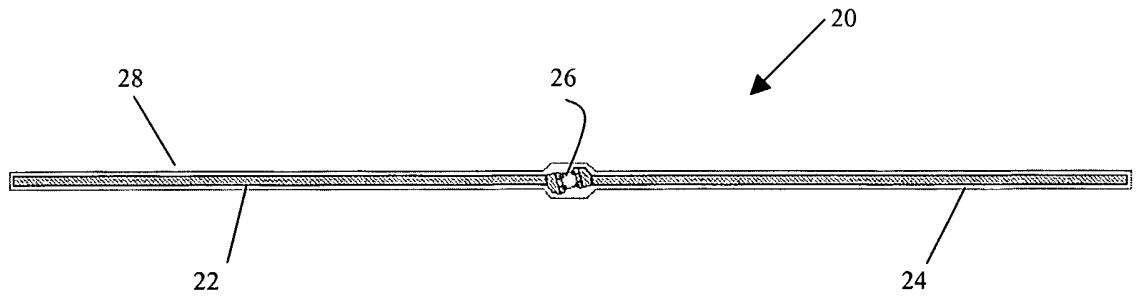

FIGURE 4

FIGURE 5A



FIGURE 5B

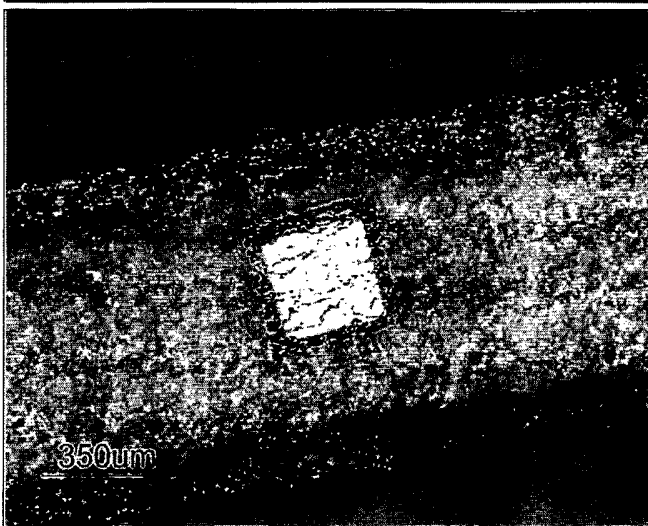

FIGURE 5C

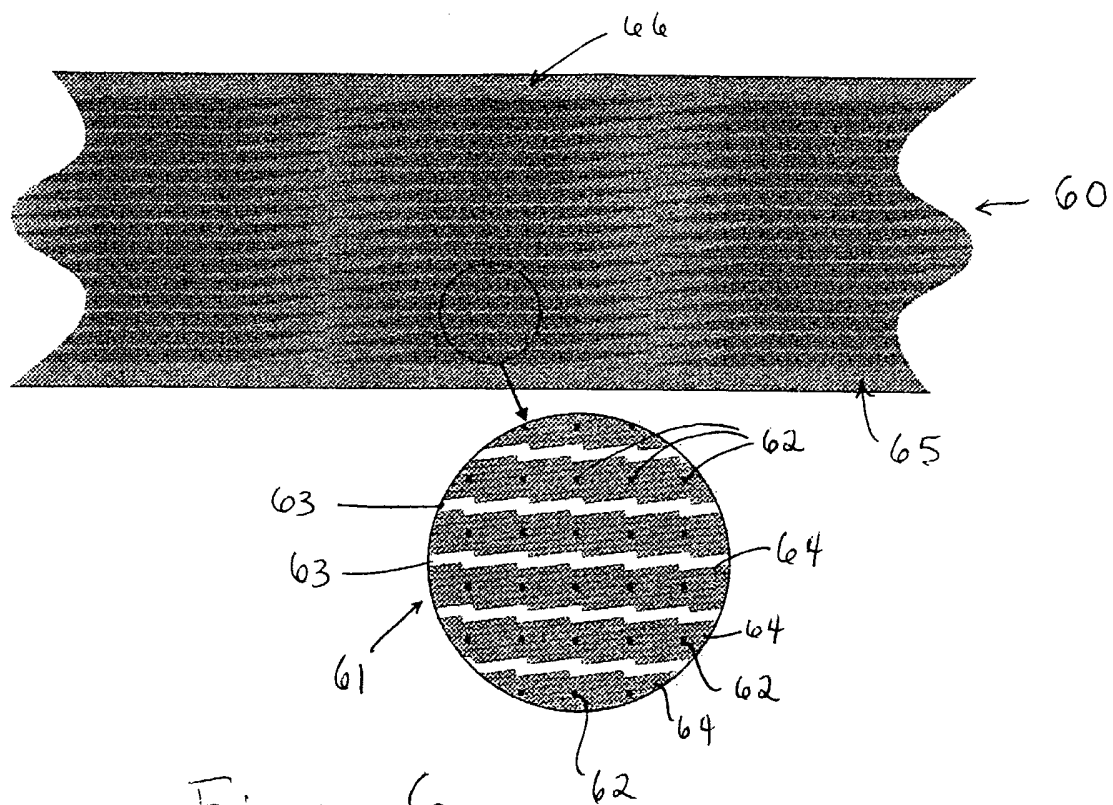

Figure 6

FIGURE 7

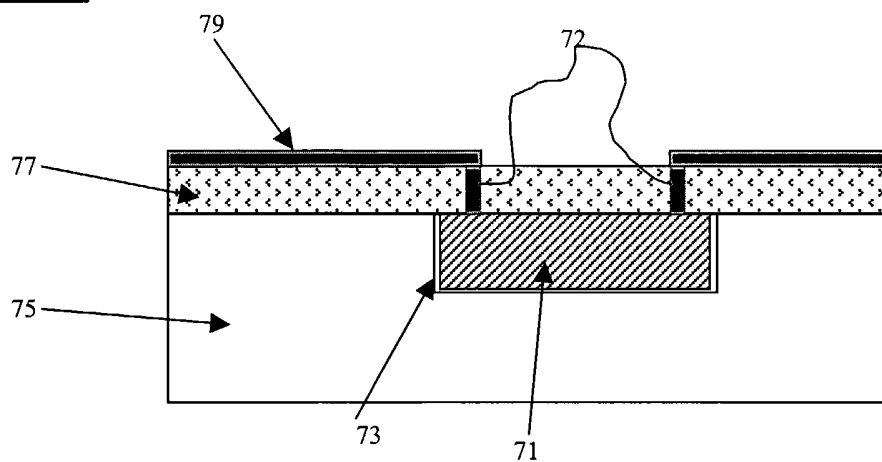
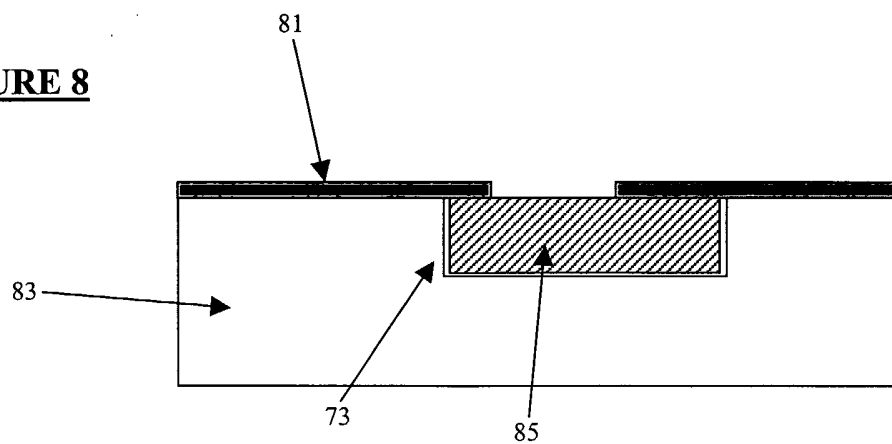

FIGURE 8



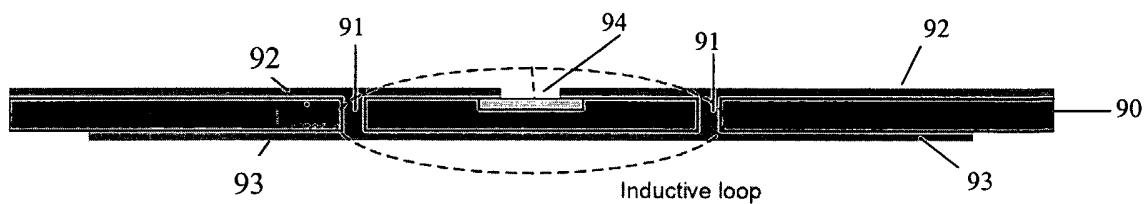
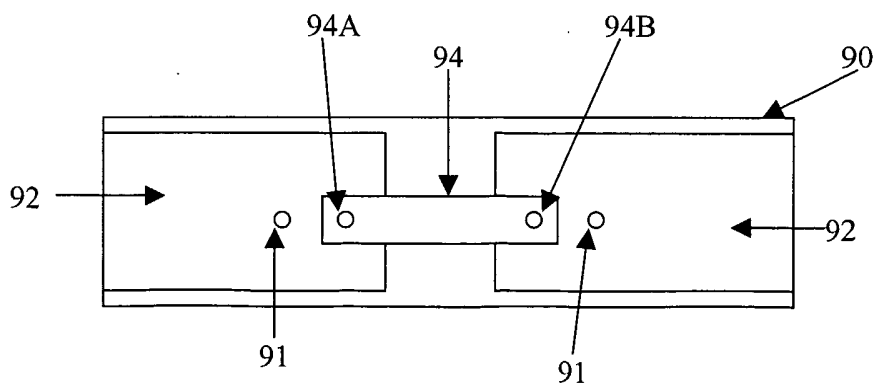

FIGURE 9A

FIGURE 9B



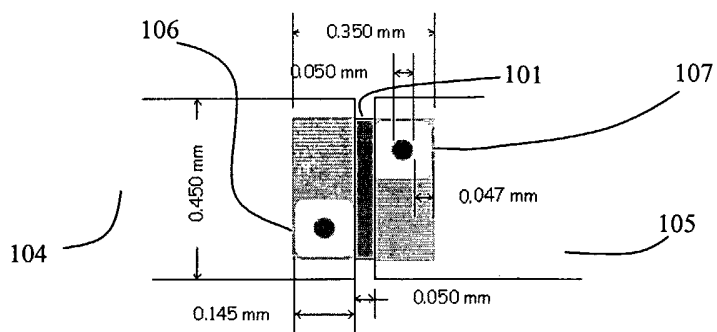
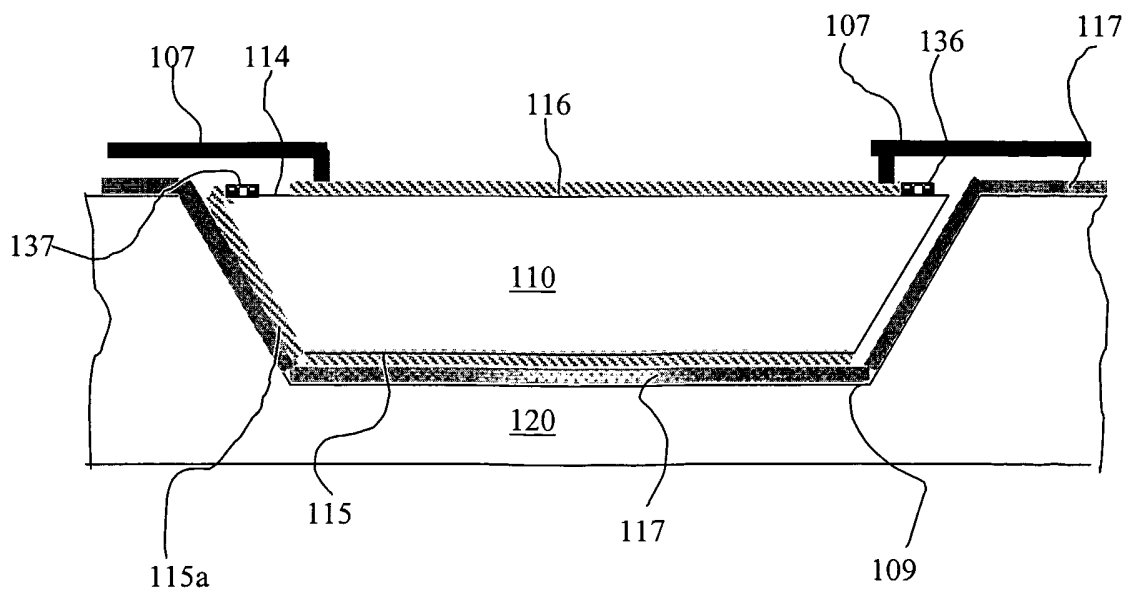

FIGURE 10

FIGURE 11



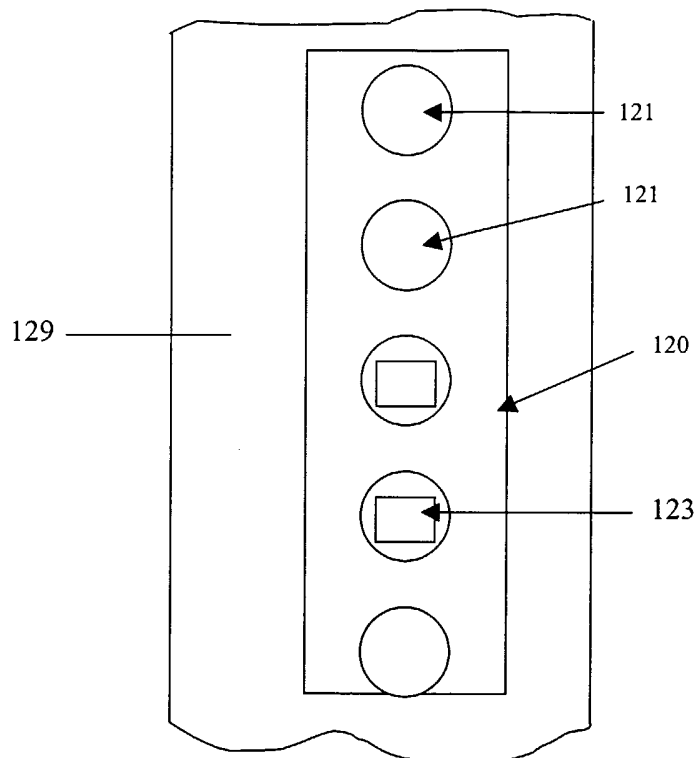

FIGURE 12

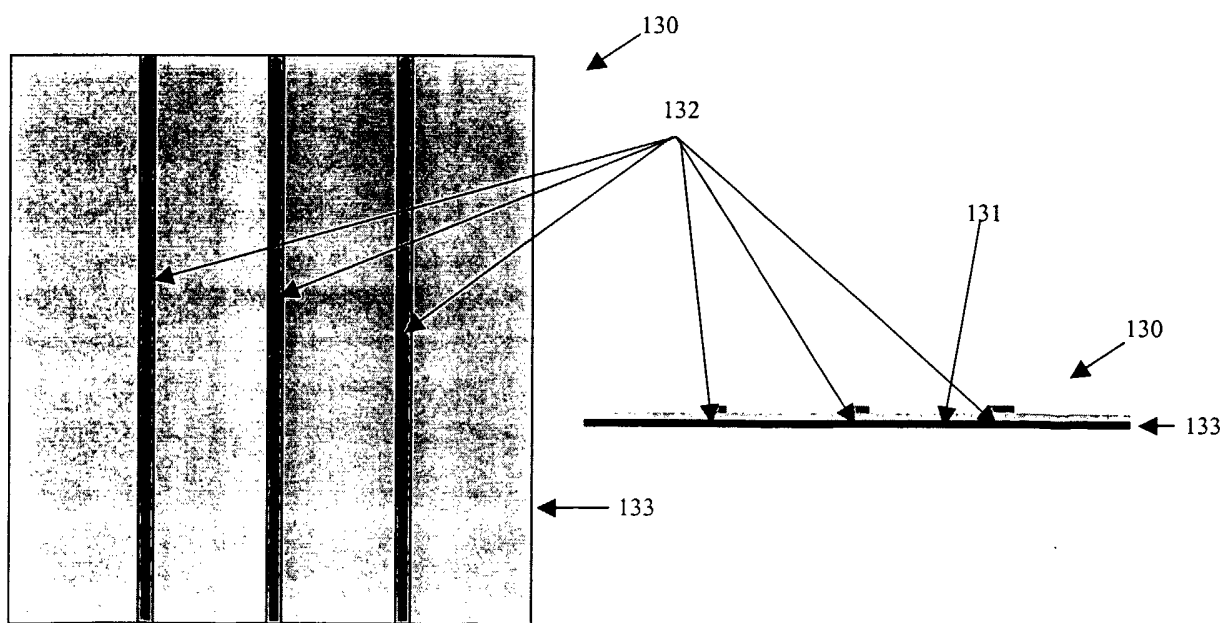

FIGURE 13A

FIGURE 13B

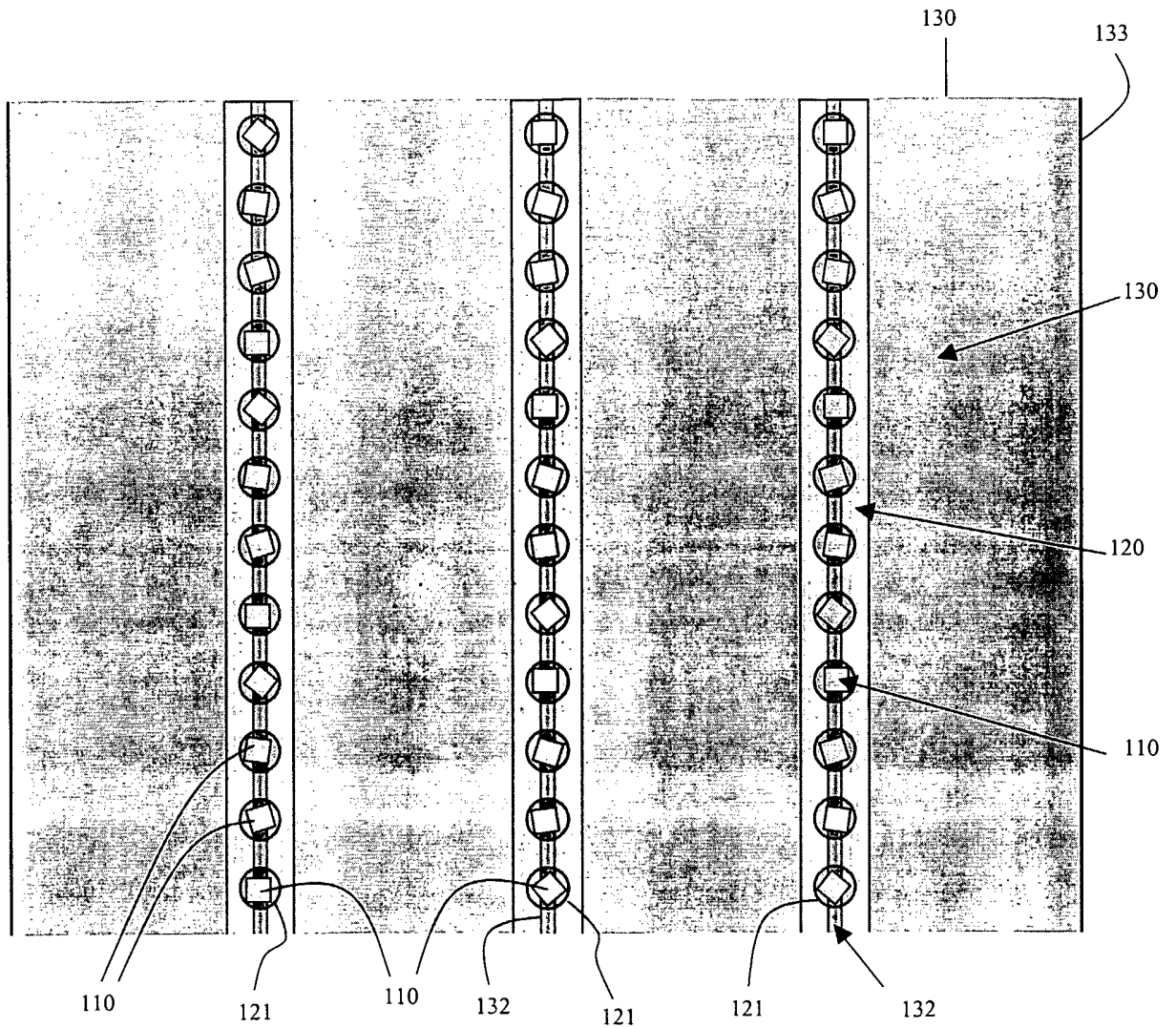

FIGURE 14A

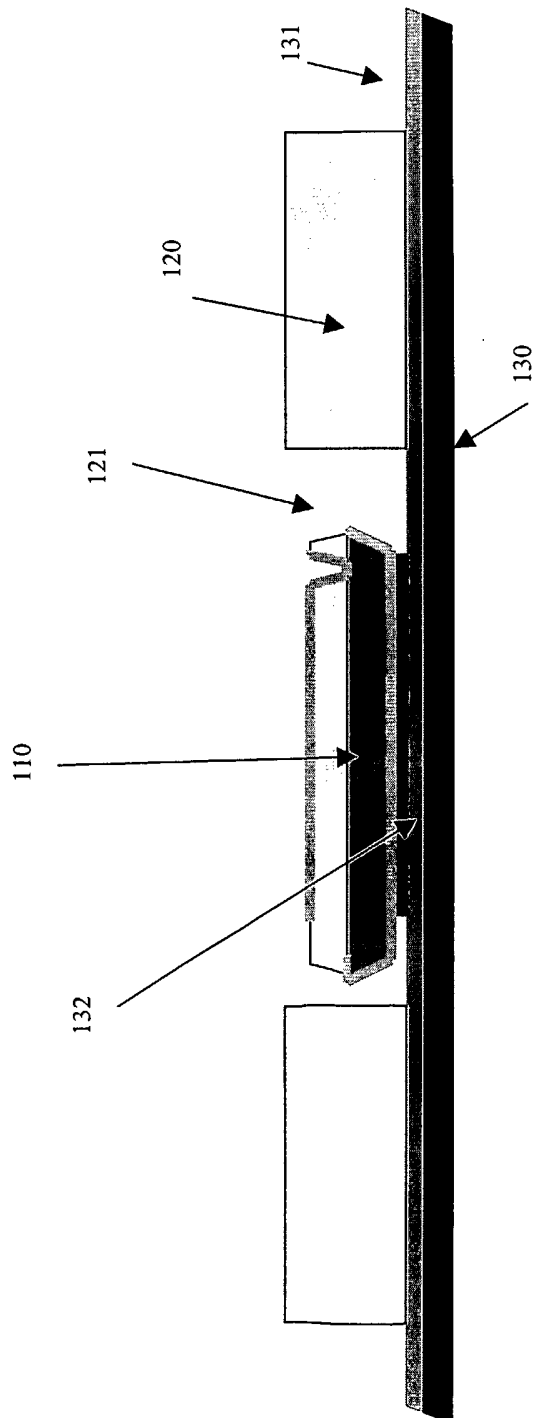

FIGURE 14B

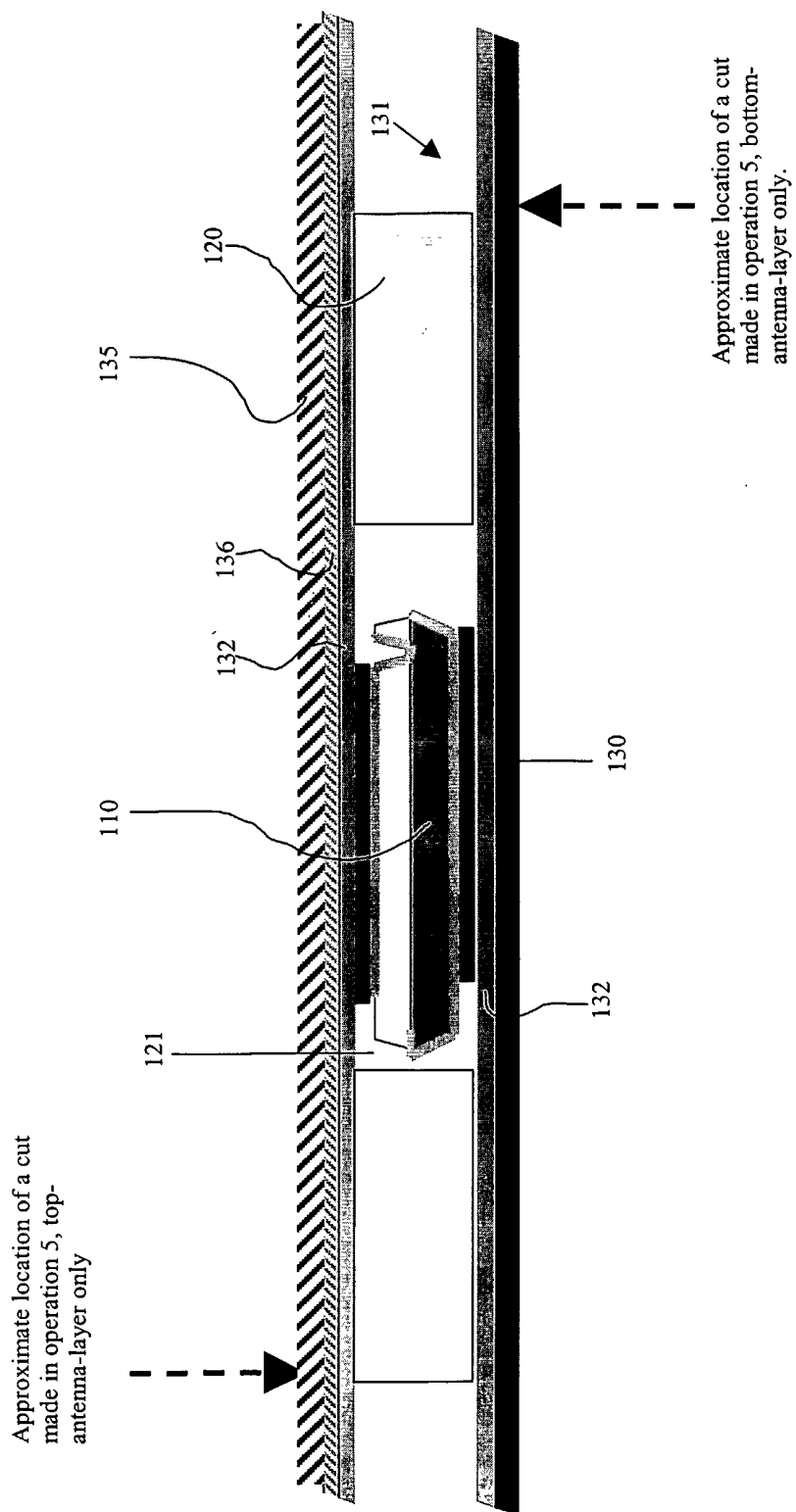

FIGURE 15

12/13

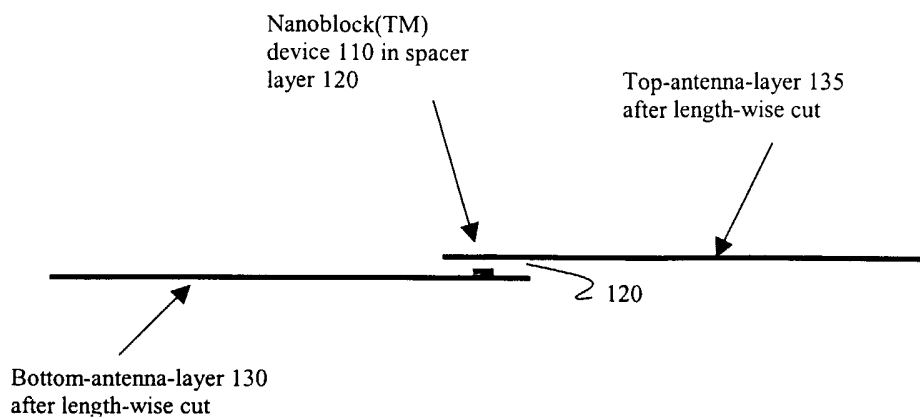

FIGURE 16

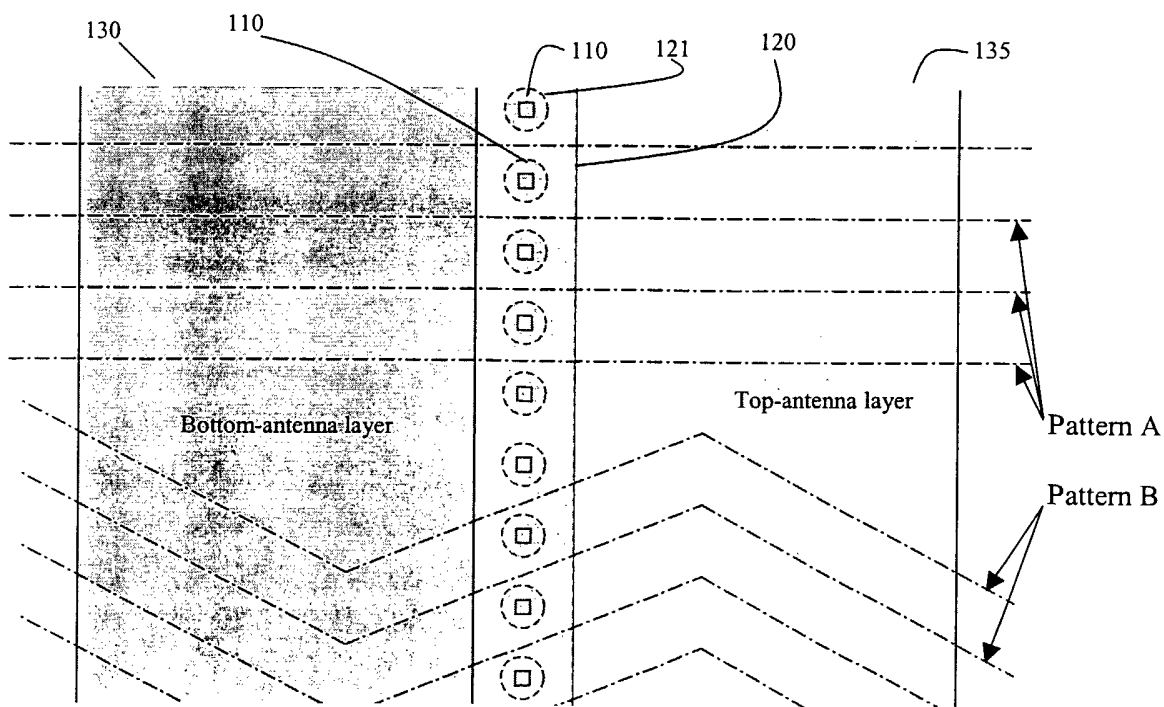

FIGURE 17

13/13

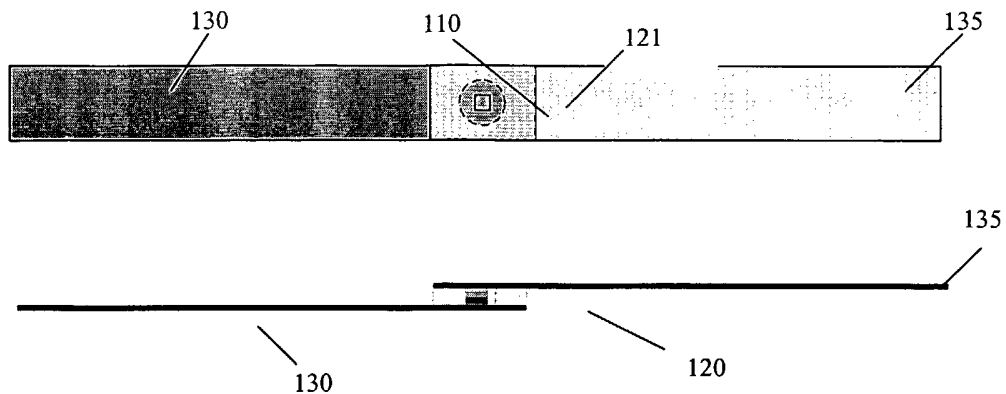

FIGURE 18

FIGURE 19

