

(19) World Intellectual Property Organization
International Bureau



(43) International Publication Date
9 December 2010 (09.12.2010)

PCT

(10) International Publication Number
WO 2010/141416 A1

- (51) International Patent Classification:
D06F 33/02 (2006.01) *D06F 58/10* (2006.01)
- (21) International Application Number:
PCT/US2010/036818
- (22) International Filing Date:
1 June 2010 (01.06.2010)
- (25) Filing Language: English
- (26) Publication Language: English
- (30) Priority Data:
61/183,050 1 June 2009 (01.06.2009) US
61/185,857 10 June 2009 (10.06.2009) US
- (71) Applicant (for all designated States except US): **THE PROCTER & GAMBLE COMPANY** [US/US]; One Procter & Gamble Plaza, Cincinnati, Ohio 45202 (US).
- (72) Inventors; and
- (75) Inventors/Applicants (for US only): **HOLLINGER, Stephan, Hubert** [DE/DE]; Friedensstrasse 62 A, 61476 Kronberg IM Taunus (DE). **KLEEMAN, Christof** [DE/DE]; Kronberger Strasse 11 B, 65760 Eschborn (DE).

SABISCH, Markus [DE/DE]; Schwalbacher Strasse 18 G, 65529 Waldems (DE). **VON SARTORI-MONTE-CROCE, Oliver** [DE/DE]; 23 Talweg, 61476 Kronberg Hessen (DE). **MESCHKAT, Stephan, James, Andreas** [DE/DE]; Sandwiese 19, 65812 Bad Soden (DE). **ULLRICH, Heiko** [DE/DE]; Sachsenring 1, 65817 Eppstien (DE). **DAMASCHKE, Robert, Hans-Joachim** [DE/DE]; Hauptstr. 32, 65760 Eschborn Hessen (DE). **BUBLITZ, Ulrich, Alexander** [DE/DE]; Sachsenhausener Strasse 4, 65824 Schwalbach am Taunus (DE). **ROSELLE, Brian, Joseph** [US/US]; 1490 Bruton Parish Way, Fairfield, Ohio 45014 (US).

(74) Common Representative: **THE PROCTER & GAMBLE COMPANY**; c/o Eileen L. Hughett, Global Patent Services, 299 East Sixth Street, Sycamore Building, 4th Floor, Cincinnati, Ohio 45202 (US).

(81) Designated States (unless otherwise indicated, for every kind of national protection available): AE, AG, AL, AM, AO, AT, AU, AZ, BA, BB, BG, BH, BR, BW, BY, BZ, CA, CH, CL, CN, CO, CR, CU, CZ, DE, DK, DM, DO, DZ, EC, EE, EG, ES, FI, GB, GD, GE, GH, GM, GT,

[Continued on next page]

(54) Title: FABRIC REFRESHING CABINET DEVICE COMPRISING A PASSIVE HEAT MANAGEMENT SYSTEM

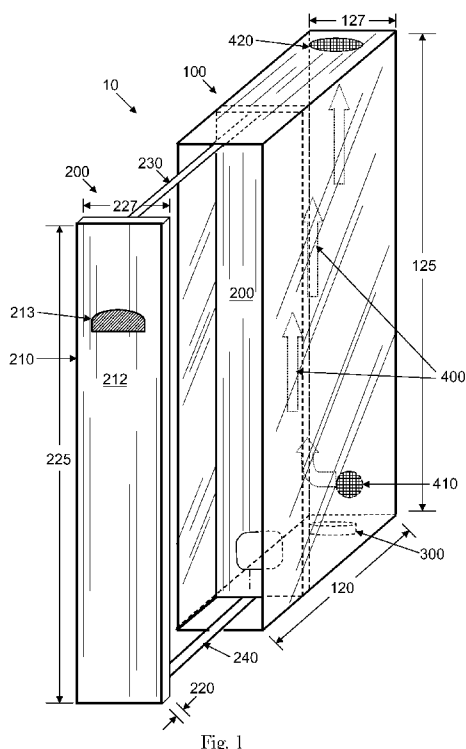

(57) Abstract: A device (10) for refreshing fabrics by reducing malodors and/or wrinkles without requiring that the fabrics to be put through an entire standard laundry process. The device comprises an extractable drawer (200) which is pulled out of the device to allow for loading of a fabric into a receiving region. The extractable drawer (200) can then be closed transporting the fabric into the interior of the device (10). A fabric treatment composition is sprayed or otherwise dispensed onto the fabrics when the device is operated. The device (10) comprises an air flow path and a heating element (300) which allows for the fabrics to be treated during use and comprises a passive heat management system within the shell (100) to minimize formation of hot spots and direct air flow away from the side walls. The extractable drawer (200) of the present invention can be positioned to extract laterally or vertically out of the shell (100) of the device (10).

WO 2010/141416 A1

HN, HR, HU, ID, IL, IN, IS, JP, KE, KG, KM, KN, KP, KR, KZ, LA, LC, LK, LR, LS, LT, LU, LY, MA, MD, ME, MG, MK, MN, MW, MX, MY, MZ, NA, NG, NI, NO, NZ, OM, PE, PG, PH, PL, PT, RO, RS, RU, SC, SD, SE, SG, SK, SL, SM, ST, SV, SY, TH, TJ, TM, TN, TR, TT, TZ, UA, UG, US, UZ, VC, VN, ZA, ZM, ZW.

EE, ES, FI, FR, GB, GR, HR, HU, IE, IS, IT, LT, LU, LV, MC, MK, MT, NL, NO, PL, PT, RO, SE, SI, SK, SM, TR), OAPI (BF, BJ, CF, CG, CI, CM, GA, GN, GQ, GW, ML, MR, NE, SN, TD, TG).

(84) Designated States (*unless otherwise indicated, for every kind of regional protection available*): ARIPO (BW, GH, GM, KE, LR, LS, MW, MZ, NA, SD, SL, SZ, TZ, UG, ZM, ZW), Eurasian (AM, AZ, BY, KG, KZ, MD, RU, TJ, TM), European (AL, AT, BE, BG, CH, CY, CZ, DE, DK,

Published:

- *with international search report (Art. 21(3))*
- *before the expiration of the time limit for amending the claims and to be republished in the event of receipt of amendments (Rule 48.2(h))*

FABRIC REFRESHING CABINET DEVICE COMPRISING
A PASSIVE HEAT MANAGEMENT SYSTEM

BACKGROUND OF THE INVENTION

Fabric treatment devices which are used to remove odors and wrinkles from clothing are known. These devices can generally be split into two categories, steam generating devices and fluid dispensing devices which wet the fabrics with water, chemical compositions, or combinations thereof. Devices of both categories typically wet the fabric with steam or the fluid, then subject the wetted fabric with heat and circulating air to allow the fabric to be dried, thereby decreasing any odors and wrinkles. Despite the many attempts to provide convenient stand alone devices for deodorizing and dewrinkling clothing, there remains a need to make devices which are time and energy efficient, consume less space, and are easy to use.

The use of steam to deodorize and dewrinkle clothing is known in the art. *See, e.g.*, U.S. Patent No. 5,815,961. Another type of fabric treating device distributes fluids, such as water and/or chemical compositions, onto the fabrics by misting within the device or distributing the fluid directly onto the fabrics. *See, e.g.*, U.S. Patent No. 6,189,346 to Chen *et al.* Yet another type of fabric treating device involves the use of ultrasonic nebulizers to distribute the fluids onto the fabrics. *See e.g.* U.S. Patent No. 6,726,186 to Gaaloul *et al.*; and U.S. Patent No. 7,367,137 Jonsson *et al.* These devices typically have metal or plastic body parts and flow heated air through the interior of the device to treat the fabrics. Heating elements and circulation of heated air is typically used to accelerate the drying time to complete the treatment cycle. In order to further decrease cycle times, the devices increase the temperature of the heating elements. One problem with the use of heating elements and circulated heated air is that hot spots can form in discreet sections of the device resulting in thermal wear and tear on the device parts. Further, fabrics treated with conventional devices tend to dry in discreet areas based on the proximity to the heat source and air flow path. To achieve sufficient drying of the entire fabric, the heating and drying cycle continues for extended periods of time, resulting in the already dried portions of the fabric often being over dried and feeling brittle and crunchy to the touch.

Despite these and other attempts to provide fabric refreshing devices, there remains a need for a device which is less susceptible to thermal wear and tear on device parts and is more efficient during the heating and drying process of the fabric treatment cycle.

SUMMARY OF THE INVENTION

One aspect of the present invention provides for a device for treating fabrics comprising: a cabinet comprising: a shell which is may be in the form of a non-collapsing cabinet comprising an opening; and an extractable drawer comprising: a drawer face comprising an outer surface; a supporting member such as a rod, pole, beam, hooks or other member capable of suspending a fabric or a fabric hung upon a fabric hanging member, wherein said drawer face and said supporting member form a receiving region adapted to operably support a fabric, and wherein said extractable drawer is adapted to fit within said shell; a heating element contained within said device; a passive heat management system, and an air flow path positioned to direct air through the receiving region. In one non-limiting embodiment, the device further comprises one or more dispensing heads positioned in the interior of the device to dispense the fabric treatment composition onto the fabrics contained in the receiving region. In another non-limiting embodiment, the device comprises one or more side protrusions formed in the sides of the shell, extending away from the device.

BRIEF DESCRIPTION OF THE DRAWINGS

FIG. 1 is a perspective view of a device in accordance with at least one embodiment of the present invention wherein the extractable drawer is in a partially opened position.

FIG. 2 is a frontal view of a device in accordance with at least one embodiment of the present invention, wherein the extractable drawer is in a closed position.

FIG. 3 is a perspective view of extractable drawer which is suitable for use any shell disclosed herein, to form a device in accordance with at least one embodiment of the present invention.

FIG. 4 is a perspective view of a device in accordance with at least one embodiment of the present invention.

FIG. 5 is a frontal view of a device in accordance with at least one embodiment of the present invention.

FIG. 6 is a perspective view of a device in accordance with at least one embodiment of the present invention.

FIG. 7 is a frontal view of a device in accordance with at least one embodiment of the present invention.

FIG. 8 is a frontal view of a device in accordance with at least one embodiment of the present invention.

FIG. 9 is a frontal view of a device in accordance with at least one embodiment of the present invention.

FIG. 10 is a frontal view of a device in accordance with at least one embodiment of the present invention, wherein the extractable drawer extends out vertically.

FIG. 11 is a perspective view of a device in accordance with at least one embodiment of the present invention wherein the extractable drawer extends out vertically like in FIG. 10.

FIG. 12 is a frontal view of a device in accordance with at least one embodiment of the present invention having a passive heat management system.

FIG. 13 is a top view of a device in accordance with at least one embodiment of the present invention having a passive heat management system.

DETAILED DESCRIPTION OF THE INVENTION

The present invention provides for a device for treating fabrics comprising: a shell which is preferably in the form of a non-collapsing cabinet comprising a opening; and a extractable drawer comprising: a drawer face comprising an outer surface; a supporting member such as a rod, pole, beam, hooks or other member capable of suspending a fabric or a fabric hung upon a fabric hanging member such as a hanger, wherein the drawer face and said supporting member form a receiving region adapted to operably support a fabric, and wherein said extractable drawer is adapted to fit within said shell; a heating element contained within said device; a passive heat management system, and an air flow path positioned to direct air through said receiving region. It has importantly been found that the passive heat management system of the present invention allows for a device which is less susceptible to thermal wear and tear and is

more efficient during the heating and drying process of the fabric treatment cycle. Without intending to be bound by theory, it is now believed that the addition of a passive heat management system such as a sheet provides important control of heat to decrease undesirable thermal wear and tear on device parts such as the shell, fasteners, adhered pieces and so forth.

PASSIVE HEAT MANAGEMENT SYSTEM:

The device of the present invention comprises a passive heat management system. Those of skill in the art will understand that the device can also comprise an active heat management system, such as an additional fan or air directing element or additional heating coils. The passive heat management system, in contrast, does not use additional energy to direct or generate heat. Rather, the passive heat management system manages the heat and air generated by the heating element and fan to increase the efficiency of the device and minimize excessive heat transfer to the exterior of the device which can lead to undesirable wear and tear on the machine, potential degradation of any plastic or heat sensitive parts.

In one non-limiting embodiment, the passive heat management system comprises one or more sheets positioned between the loading area of the fabric and one or more side walls of the device. One or more sheets may cover the entire inner surface of the device or some portion thereof. The sheets may be of any shape. For instance, non-limiting embodiments include sheets that are generally planar, sheets that include arcuate portions, or combinations thereof. In one non-limiting embodiment, the passive heat management system comprises two sheets. In one non-limiting embodiment the sheets may be generally planar sheets having a greatest planar area of about 1.0 ft² (0.1 m²) to about 20.0 ft² (1.9 m²), alternatively from about 3.0 ft² (0.3 m²) to about 15.0 ft² (1.4 m²), alternatively from about 5.0 ft² (0.5 m²) to about 10.0 ft² (0.9 m²). In one non-limiting embodiment, the area of the sheet is from about 25% to about 90% of the planar area (the area of a plane projected over the same two dimensional shape as the sheet) of the device, alternatively from about 40% to about 80%, or alternatively at least about 60%. The sheet or sheets are positioned to be parallel to the plane of the device and could be removably positioned to be adjacent to the interior of at least one of the side walls of the device. In one non-limiting embodiment, each of the side walls of the device has one sheet. In another embodiment, the majority of the interior of the shell is lined with a sheet, alternatively at least about 60% of the interior, alternatively at least about 75% of the interior, alternatively at least

about 85% of the interior, alternatively at least about 90% of the interior. Without intending to be bound by theory, it is believed that the sheets not only provide protection from thermal wear and tear but can also provide protection from the fluids. This is believed to reduce heat loss to the environment outside the device, decrease thermal expansion of any parts of the shell of the device, and also allow the device to feel cool to the touch during operation.

In one non-limiting embodiment the sheet has a sheet thickness of from about 0.006 mm to about 2 mm, alternatively from about 0.01 mm to about 1.5 mm, or alternatively from about 0.5 mm to about 1 mm. In one non-limiting embodiment, the sheet is corrugated. In another non-limiting embodiment, the sheet is apertured having a plurality of apertures having an average aperture area of from about 0.5 cm² to about 9 cm² or alternatively from about 1 cm² to about 4 cm². The apertures may have the same or different shapes or a combination thereof, non-limiting examples of which include circles, squares, hexagons, etc. In one non-limiting embodiment the apertures form three dimensional cones or pockets extending away from the plane of the sheet, which can appear as a waffle type sheet. In one non-limiting embodiment where the sheet has a three dimensional aspect such as from the corrugated sheet or apertures, the three dimensional thickness of the sheet can be from about 1 mm to about 4 cm, alternatively from about 1 cm to about 3 cm, or alternatively less than about 2 cm.

In one embodiment, the sheet has a heat transfer coefficient which is sufficiently high to allow the material to absorb and transfer heat sufficiently fast to decrease the formation of hot spots in the inner wall or lining of the device during the heat addition phase. Uniform temperature distribution when heating is believed to help promote uniform drying performance. Conversely, another aspect of this design is the ability of the sheet to cool down quickly when heat is removed. Quick cool down of an internal wall is important from an operational safety standpoint to avoid burns in the event an individual should touch the inner wall shortly after the heating process has finished. In one embodiment, the sheet has a heat transfer coefficient which is greater than the heat transfer coefficient of the material used to make the walls of the shell. In one embodiment, the sheet is made of a material having a thermal conductivity, measured at 25 °C, of from about 5 W/(mK) to about 430 W/(mK), alternatively from about 10 W/(mK) to about 400 W/(mK), alternatively from about 15 W/(mK) to about 300 W/(mK), or alternatively from about 30 W/(mK) to about 250 W/(mK).

Non-limiting examples of suitable materials for the sheet include metals such as aluminum, stainless steel and so forth. Non limiting examples of suitable sheet materials include Nopal[®] corrugated aluminum sheets made by Dietrichs Presswerk Darmstadt of Germany.

Without intending to be bound by theory, it is believed that using a sheet between the receiving area of the fabric and one or more side walls of the device can provide operational benefits in managing the heat of the system. Of particular interest is the desire to maximize the containment of the heat on the inside of the device before it is vented so it may be available for the treatment of fabrics, rather than sinking excessive heat into the internal and external wall structures. While it is desirable to manage the heat towards the inside of the treatment device, at the same time it is desirable to avoid heat induced stress problems on the internal walls and components of the device while doing so. It is believed that the passive heat management system of the present invention allows for decreased formation of hot spots in discrete sections of the device such as parts of the shell, and allows for more efficient transfer of heat towards the receiving region of the device, ultimately towards the fabrics being treated. This is believed to allow for more efficient drying of the fabrics with decreased wear and tear on the device.

In one preferred embodiment, the sheet acts as a heat manager maintaining heat from the heating cycle to the inside of the device and decreasing the heat transferred to the outside walls of the shell. In one non-limiting embodiment, the sheet comprises a single layer of material. In another non-limiting embodiment, the sheet comprises more than one layer of the same or different materials, wherein the layers can be adhered or otherwise attached to one another or can just be adjacent and not permanently attached to one another.

Without intending to be bound by theory, it is believed that having a material of low heat capacity and low coefficient of linear expansion is desirable. Materials of lower heat capacity will reach a given operational temperature with a lower amount of heat uptake. Materials of lower coefficient of linear expansion will expand less for a given temperature increase, which can reduce the amount of internal heat inducted stress as a result of the heat expansion.

It may be desirable to have coefficients of linear expansion of from about 2 to about 100 ($\times 10^{-6}$ in/in- $^{\circ}$ F), alternatively from about 2 to about 80 ($\times 10^{-6}$ in/in- $^{\circ}$ F), or alternatively from about 2 to about 60 ($\times 10^{-6}$ in/in- $^{\circ}$ F). Without intending to be bound by theory it is believed that in some cases it may be desirable to utilize wall materials having higher thermal conductivity in order to speed up temperature equalization within the internal wall material thus promoting

uniform temperature distribution within the device and minimizing localized hot spots. It is believed that more uniform temperature distribution in the device will result in more uniform drying performance. Without intending to be bound by theory, it is believed that the sheet can expand and contract when the temperature within the device changes without unduly impacting the structural integrity of the device. It is believed that if a passive heat management system is not used, the shell of the device may prematurely degrade and/or crack due in part to thermal expansion and contraction from the heating cycles. As such, it has been found that incorporating a sheet absorbs a portion of the heat thereby decreasing the expansion or contraction of the shell.

In one non-limiting embodiment the sheet may be further coated with a corrosion resistant coating to protect the sheet from the fluids sprayed within the device. For example, in embodiments where the fluid has a high pH which can be corrosive to metals or plastic parts, the sheet may be coated or galvanized to resist corrosion. Non-limiting examples of suitable coating technologies include coatings of zirconium, tin, chromium, titanium, fluoride, phosphates, hafnium, copolymers of vinylidene salts and acrylic/itaconic acids and mixtures thereof, such as described in US Patent Nos.: 4,273,592; 4,148,670; 3,952,698; and 3,286,904.

In another non-limiting embodiment, a metalized or conductive lining to the device may provide for a charged surface to be used in conjunction with electrostatic spraying as a means to assist the deposition of charged spray compositions unto fabrics contained within.

In another non-limiting embodiment, at least a portion of the sheet is reflective, preferably the portion of the sheet facing away from the adjacent side wall. In one embodiment, only a portion of the surface of the sheet face, facing away from the adjacent side wall (facing towards the receiving region) is reflective. The portion can be a minor portion positioned in a specific region to maximize heat reflection, or can be greater than about 50% of the sheet face. The sheet itself can be reflective, such as from a polished metal or plastic such as the materials disclose herein, or the sheet can be coated with a reflective coating. Reflective as used herein includes both embodiments where the sheet itself is reflective and where a reflective coating is used. In one non-limiting embodiment, the entire sheet is reflective. In one non-limiting embodiment, the sheet is reflective for light or radiation in the infrared frequencies. In one embodiment, the sheet has the reflectivity of a mirror. Those of skill in the art will understand that lesser degrees of reflectivity can still be useful, such as a polished aluminum or stainless steel, chrome, glossy or high gloss paint, metallic paint, etc. By including a reflective element

on the portion of the sheet facing the fabrics, additional heat can be directed towards the fabrics during the drying cycle. In one non-limiting embodiment, the entire face of the sheet facing the fabric receiving portion of the device is reflective. In another non-limiting embodiment, the sheet is designed to direct air towards the center of the device where the fabrics are positioned. Air would also thereby be directed away from the side walls, thereby further decreasing the transfer of heat to the shell.

In one non-limiting embodiment, the sheet is adjacent to at least one side wall of the device such that certain portions of the sheet are in contact with the side wall. In one non-limiting embodiment where the sheet is corrugated or has apertures extending away from the plane of the sheet, the sheet can be in contact with the side wall at the discrete sections of the sheet which extend farthest from the plane towards the side wall. Without intending to be bound by theory, it is believed that this forms a volume of air between the sheet and the side wall which can act as a form of thermal insulation decreasing the transfer of heat to the side wall. In the case where an effective air volume amount is located between the sheet and an external wall, the heat management sheet may have a high thermal conductivity but the rate of overall heat transfer out of the device may be controlled by the heat transfer properties of the air layer and the outside wall. The air barrier and outside wall, with lower heat transfer coefficients than the sheet, make the overall heat transfer coefficient low for heat flow out of the device, thus keeping the outer walls of the device cool. In this way, conductive, convective and radiation heat can be managed within the device for effective use during treatment with heat removed in a controlled fashion at the designed outlet of the device.

Further, the passive heat management system can act as a barrier minimizing contact between any fluids dispersed within the device onto the interior portion of the shell of the device. The passive heat management system can be coated or treated such that it is resistant to corrosion. Stray portions of fluid which are not deposited onto the fabrics would then be able to contact the passive heat management system. Without intending to be bound by theory, it is believed that decreasing contact between the shell and excess fluid and decreasing excessive heat transfer to the shell will decrease wear and tear, corrosion stress cracking, and potential damage to the device. Further, in one non-limiting embodiment, the passive heat management system is removable such that the user or manufacturer can remove the system if its benefits are not desired. The removable passive heat management system can also be replaced with new or

different elements for cleaning purposes or if a passive heat management system having a different heat transfer coefficient, linear thermal expansion coefficient, reflectiveness, air directing properties, etc, is desired.

As used herein, fabrics include one or more items of clothing, garments, textiles, towels, table cloths, drapes, chair covers, and the like. As defined herein, "operably support" means that the suspending member is capable of directly supporting a fabric hung thereon, or of supporting a fabric hanging member which can have a fabric hung thereon.

In one non-limiting embodiment, the device comprises a footprint which is compact in width such that the device can be used in a bedroom, closet or other living space where larger wider devices are inconvenient. The small footprint width of the present device is achieved from the extractable drawer design. The present invention occupies less horizontal floor space compared to devices which include a hinged door because the extractable drawer consumes the same or a smaller horizontal footprint compared to the shell of the cabinet compared to conventional hinged doors which include a wider footprint from the sweeping action of the hinged doors. As such, the present device is more compact and convenient to use in various rooms of the home. Further, the present device is believed to appear more streamlined than conventional devices and is suitable for use in varying rooms in a home and provides sufficient spray or misting capability to effectively wet the fabrics quickly, yet still achieves an effective distribution of the composition.

It has been determined that it may be desirable to construct the shell to have a larger peripheral size than the drawer face of the extractable drawer, when the device is viewed facing the drawer face of the expandable drawer. In one embodiment, at least one portion of the shell extends laterally or horizontally beyond the periphery of the drawer face of the extractable drawer, such as when the device is viewed in a frontal view. *See e.g.* FIG. 2. In one embodiment, one or both of the sides of the shell extend beyond the periphery of the drawer face of the expandable drawer. In yet another embodiment, the side portions of the shell further comprise one or more side protrusions which further extend beyond the periphery of the drawer face and provide greater lateral distance from the receiving region of the extractable drawer. By extending the lateral width of the device, the present invention is able to facilitate the inclusion of dispensing heads (including but not limited to sprayer heads, , hydraulic nozzles, sonic or ultrasonic nebulizers, pressure swirl atomizers, high pressure fog nozzle, and combinations

thereof) positioned at a desired distance from any fabrics contained within the device. Extending the periphery of a portion of the shell beyond the periphery of the drawer face of the extractable drawer allows the device to increase the distance between the dispensing heads to the fabrics without requiring that the entire device be made to have an unnecessarily large width. Further, by minimizing the width of the drawer face, yet providing for a shell which extends laterally or horizontally beyond the periphery of the device, or one or more side protrusions, the device appears thinner, yet can still achieve sufficient composition distribution onto the fabrics.

FIG. 1 is a perspective view of a device **10** for treating fabrics comprising a shell **100** forming at least one opening, wherein the extractable drawer **200** is in a partially opened position. In this embodiment, the extractable drawer is shown as a frontal drawer which can be pulled out or actuated out of the opening formed in said shell via any suitable mechanical or manual means. Non-limiting examples of mechanical means to extract the drawer include spring loaded drawers, chain driven drawers, and levered drawers. In another non-limiting embodiment, the extractable drawer can be positioned to exit the shell in an upwards or vertical direction as opposed to a lateral or horizontal direction. *See* FIG. 10 compared with FIG. 1. In one embodiment, the extractable drawer comprises one or more sliding members such as a wheel or glide with or without roller bearings, which can be adapted to slide along a rail provided from said shell. In one embodiment the shell is a non-collapsing member comprising a pair of side walls, a top, a front wall, a rear wall and a base wall, wherein at least a portion of one of said top, front wall and rear wall can be formed from said drawer face of said extractable drawer. The extractable drawer **200** comprises a drawer face **210** having an outer surface **212**. In one embodiment, said drawer face at least partially seals said opening of said shell in a closed position. Where the drawer face does not fully seal the opening of said shell, a gap in the seal can perform the function of an inlet and/or outlet vent in the venting system of the device. In another embodiment, the drawer face fully seals said shell in a closed position. In yet another embodiment, the outer surface of the drawer face forms a flush closure with the shell.

The extractable drawer is shown with an optional handle **213** for accessing the extractable drawer from the interior of the shell. The extractable drawer further comprises a supporting member **230** which can operably support one or more fabrics, said drawer face supporting member form a receiving region for said fabric. Suitable supporting members include a rod, pole, beam, rope, cord, or hooks extending from the drawer face into the interior of the

shell. In one embodiment, the supporting member further comprises a hook or notch to support a fabric hanging member such as a hanger. In another embodiment, the supporting member supports a hanger fixedly or removably attached to said supporting member. In another embodiment, the supporting member further comprises a telescoping section which allows the supporting member to be extended or retracted. In one embodiment, the device further comprises a tensioning system which can assist in the removal of wrinkles from the entire fabric or a discrete section of the fabric. In one embodiment, the tensioning system is provided by the hanger in conjunction with the extractable drawer. Suitable tensioning devices known in the art include expanding hangers, hanging weights or poles or rods which can be used to drape or stretch the fabrics over and/or around. Additional non-limiting examples of tensioning systems are disclosed below.

The extractable drawer is shown with an optional rear face **220** and an optional base **240**. In this position, the rear face is contained within the shell such that the extractable drawer is not fully detached from the device. In one embodiment, the extractable drawer is a fully detachable drawer meaning that it can be removed from the shell. In another embodiment, the extractable drawer is movable but attached to the shell such that the extractable drawer can be slidably contained within the shell but cannot be completely removed. The drawer face **210** is shown connected to said rear face **220** by said supporting member **230**. Although the supporting member shown in FIG. 1 is shown attached to both the drawer face and the optional rear face, the supporting member can be connected to either of the drawer face or the optional rear face. Alternately, the supporting member may be hingedly attached to either of the drawer face and the rear face. One important benefit obtained by providing a rear face which fits within the interior space of the shell, the user is limited in exposure to the condition of the side walls or any tubes or wires provided therein. It is believed that upon repeated use, the interior of the side walls can collect residue or buildup from the fabric treatment composition sprayed or misted within the device and evaporated from the fabrics. By providing a rear face in the extractable drawer, the user exposure to the interior of the side walls is limited. Further, the rear face adds an aspect of safety as the user cannot access any tubes, hoses, wires or electronics contained within the shell.

The device shown in FIG. 1 further comprises a heating element **300** and an air flow path **400**. When the extractable drawer is in a closed position, the air flow path directs at least a portion of the air to and/or through the receiving region. The heating element can be positioned

within the shell at any location which allows the heating element to transfer heat, either through convection, conduction, or radiation, to the interior of the shell, particularly to the receiving region, more particularly to any fabrics contained within the receiving region. Suitable heating elements include heating wire or coil, an infrared lamp, a microwave heating element, and combinations thereof. In this embodiment, the heating element **300** can be provided to be flush with the lower portion of the shell such that it does not obstruct the closing of the extractable drawer when the rear face is moved towards the back of the shell.

The air flow **400** is facilitated by a venting system comprising an inflow vent **410** and an outflow vent **420**. In one embodiment, the inflow vent is positioned below the outflow vent. This is believed to allow for natural convection and movement of the heated air to escape without the need for active air flow. In another embodiment, the inflow vent is positioned above the outflow vent. Air flowing from the inflow vent to the outflow vent can be by natural convection or via forced draft. In the case of forced draft, a fan or other forced air movement means can be inserted in the air flow path. Preferably the fan is near the inflow vent **410** or the outflow vent **420** in order to avoid interference with the sliding door mechanism. The air flow means can be of any design but typically will be a fan of radial, centrifugal, or crossflow blower design as needed to achieve the desired flow rate.

In one embodiment, the outflow vent comprises an air filter system such as a charcoal filter. The air filter system can be used to capture malodors from the treated fabrics or interior of the device and/or used to capture excessive fragrance or perfumes provided from the fabric treatment composition. Without intending to be bound by theory, it is believed that by providing an air filter system in the outflow vent, any malodors released from the fabrics will not be released into the ambient air surrounding the device. This is particularly desirable when the device is used in the home in the bedroom or other rooms where the released malodors may be noticeable. The air filter system is preferably replaceable. In another embodiment, the outflow vent comprises a chemical capture member to remove moisture and/or other materials from the effluent. In another embodiment, the device further comprises an air filtering and/or treatment system. In one embodiment the inflow vent can be positioned below the outflow vent such that cool ambient air can be sucked into the shell by the movement of the heated air within the device (heated by the heating element **300**). The heated air moving up the receiving region will pass over and through any fabrics located in the receiving region allowing the fabrics to dry. Without

intending to be bound by theory, it is believed that the heat allows for control or killing of certain microorganisms and bacteria as well as removal of odor causing entities which can be present on the fabrics. This anti-microbial benefit is believed to be the result of subjecting the fabrics to a sufficiently high temperature to control, remove, and possibly kill the microorganisms and/or bacteria.

In one embodiment the air treatment (freshening, deodorizing, disinfecting, etc) system is part of or, provided in the vicinity of, the outflow vent such that air expelled from the device carries with it air treatment ingredients. Non-limiting examples of suitable liquid active materials comprise perfumes, air fresheners, deodorizers, odor eliminators, malodor counteractants, household cleaners, disinfectants, sanitizers, repellants, insecticide formulations, mood enhancers, aroma therapy formulations, therapeutic liquids, medicinal substances, or mixtures thereof. These and other suitable actives are disclosed in U.S. Patent No. 7,490,815 issued in the name of Tollens *et al.* In one embodiment, the device allows the consumer to manually or automatically determine the dosage rate and/or frequency of doses for emitting the air treatment composition. Although the air treatment device can be part of the outflow/venting system (such as by using the expelled air to emit the air treatment ingredients) the air treatment device can also be a separate element from the outflow venting system.

Those of skill in the art will understand that where a vent or heating element is provided in the device in the vicinity of the rear face when the device is in a closed or operating position, the rear face is designed such that air and/or heat can pass through the one or more apertures formed in the rear face to enter the receiving region and fabrics supported within the device. The passive heat management system of the present invention is preferably positioned such that heat generated by the heat element and/or heated air being circulated within the device flow over or past the passive heat management system. In this way, the passive heat management system can absorb heat from the active heat generating (heating element) and control elements (air flow path). Preferably, the passive heat transfer system absorbs and redirects thermal energy towards the receiving region of the device to allow for even transfer of heat to the entire fabric positioned therein so as to have a more even drying pattern and shorter drying time. Further, the passive heat transfer system is believed to reduce the occurrence of hot spots in the device which decreases thermal expansion in discreet sections of the device which can lead to problems such as cracking and structural degradation of the component parts of the device.

As such, in one embodiment, the rear face comprises one or more apertures positioned to facilitate the passage of the air through said air flow, and to allow heat to enter the receiving region and to exit the device with any evaporated fabric treatment composition and malodors. Further, where internal parts such as wires and dispensing heads are provided in the interior of the device, the rear face is operably designed such that upon opening and closing the extractable drawer, the rear face does not strike any internal parts of the device. In yet another non-limiting embodiment, the opening or closing of the extractable drawer further actuates other elements which would allow the device to begin running.

The device depth **12** (not shown) can be calculated by measuring the total depth of the device when the extractable drawer is in a closed position within the shell. In one embodiment, where the drawer face does not recede into the shell, the device depth would be equal to the sum of the shell depth **120** and the drawer face depth **220**. Where the drawer face recedes into the shell such that the outer surface of the drawer face is flush with the shell, the device depth is equal to the shell depth **120**. In one non-limiting embodiment, the device depth is from about 24 inches (61 cm) to about 60 inches (152 cm), alternatively from about 30 inches (76 cm) to about 48 inches (122 cm), alternatively from about 36 inches (91 cm) to about 42 inches (107 cm). The shell also comprises a height **125**.

Further, as shown in this embodiment, the shell has a width **127** and the drawer face has a width **227**. In one embodiment, the device has a greatest lateral width of less than about 28 inches (71 cm), alternatively less than about 20 inches (51 cm), alternatively less than about 16 inches (41 cm), alternatively less than about 12 inches (31 cm). As defined herein, the greatest lateral width is determined when the device is viewed in a frontal view. The greatest lateral width can be measured at the base, the shell or any protrusions extending away from the shell, or the drawer face of the extractable drawer, depending on which element has the greatest width. In one non-limiting embodiment, the device comprises a width ratio, as defined by the ratio of the greatest lateral width of the device to the greatest lateral width of the drawer face of the extractable drawer, of from about 9 to about 1, alternatively from about 4 to 1.2, alternatively from about 2 to 1.5.

Importantly, it has been found that by providing a device having a width ratio of less than about 2, it provides the desired appearance that the device has the general width of the door, yet

allows for an increase in the distance from the fabrics located in the receiving region to the position of the sides of the device where the dispensing heads are located.

In one non-limiting embodiment the device comprises a footprint aspect ratio of from about 1 to about 30, alternatively from about 2 to about 15, alternatively from about 3 to about 10, or alternatively about 5. The footprint aspect ratio is a ratio of the greatest lateral length of the device **12** to the greatest lateral width of the device, such as from the optional base stand or the shell width. It has surprisingly been found that the present invention is versatile and can be suitably placed in many different areas when used in a domestic capacity. For example, the present device can be placed alongside a conventional washer and/or dryer device when used in the laundry area of a home. Importantly, by providing a device which has a footprint aspect ratio as defined herein, the device is versatile and can be used and fit into small spaces such as in the bedroom or other living area, along side a wall or within a closet. The device can be placed alongside a cabinet, dresser, TV stand, or couch. Importantly, when the device is opened, the footprint width does not increase. Devices which include one or more hinged doors or releasably sealed openings, such as by zipper, attached to a cabinet require larger footprint widths because the doors or openings tend to swing or drape beyond the width of the device when in an open position. It is believed that by providing a device having the dimensions as defined herein, the appearance of the device is considerably less obtrusive compared to fabric treatment and refreshing devices disclosed in the art. It is also believed that by providing a device having the dimensions as defined herein, the device will be more readily and conveniently used in the bedroom or other living areas, making the device more readily accessible to a user during the act of dressing, undressing, changing-clothes and the like.

FIG. 2 is a frontal view of a device in accordance with the present invention, wherein the extractable drawer **200** is in a closed position. The shell **100** can comprise a larger width than the drawer face of the extractable drawer. In one embodiment, the device further comprises one or more protrusions extending beyond the frontal planar periphery of the drawer face **210**. In this embodiment, the protrusion comprises the shell **100**, shown having a larger width, height than the drawer face. In addition, FIG. 2 shows two additional side protrusions **130** formed on the side walls of the shell. As such, the shell width **127** is now measured as the widest lateral distance between the two points on opposing sides of the shell when measured on a plane perpendicular to the center line **14** of the device. As defined herein, the center line is the central

axis of the device. The side protrusions can be provided in a variety of suitable shapes which allow for a slight increase in the distance between dispensing heads and suspended fabric.

The device of the present invention further comprises a plurality of dispensing heads **620** positioned on the side walls of the shell **200**. In one suitable embodiment, the dispensing heads comprises one or more sprayer heads and optionally one or more ultrasonic nebulizers. Dispensing heads are preferred where the flow rate of the fabric treatment composition is desired to be high, for example greater than 2 grams of fluid per minute per nozzle. Non-limiting examples of suitable dispensing heads and sprayer heads are provided in U.S. Serial No. 61/163924 to Meschkat *et al*, filed March 28, 2009. In one embodiment, where the device comprises one or more of said side protrusions **130**, one or more of the dispensing heads **620** can be positioned on the interior of the side protrusion to increase the lateral distance between the head **620** and any fabric contained within the receiving region. Those of skill in the art will understand that by providing two or more sets of dispensing heads positioned on each side wall of the shell, the fabric can be wetted in a faster more efficient manner. Further, by increasing the horizontal distance between the dispensing heads and the fabric, the dispensed fluid has more space to disperse and cover more area on the fabric.

In one non-limiting embodiment, the device comprises a lateral distance between the receiving region where a fabric is placed (which can be determined as the central line or axis **14** of the device) and at least one dispensing head positioned on either a side wall of the shell or on a side protrusion of less than about 12 inches, alternatively less than about 8 inches, alternatively less than about 6 inches and at least about 4 inches, alternatively at least about 6 inches, alternatively at least about 10 inches. FIG. 2 further shows an optional dispensing heads **623** positioned at the top of the shell, oriented to spray downwards onto any fabric within the device. Additional spray heads can be placed throughout the interior of the device such as on the interior portion of the drawer face or rear face, or base **240** where the dispensing heads are preferably situated for maximum fabric coverage, avoiding spray interference by any of the supporting members.

In one non-limiting embodiment where the dispensing heads comprise one or more sprayer heads, the sprayer heads preferably comprise one or more spray nozzles, such as 2, 3, 4, or 6 spray nozzles. Multiple sprayer nozzles in the sprayer head allow for effective distribution of a benefit composition directly to a garment to be treated to minimize application time.

Dispensing of a benefit composition can be achieved using any suitable device such as a hydraulic nozzle, sonic or ultrasonic nebulizers, pressure swirl atomizers, high pressure fog nozzle or a combination thereof, to deliver target particle sizes and coverage pattern. Non-limiting examples of suitable nozzles include nozzles commercially available from Spray Systems, Incorporated of Pomona, California, under the Model 40 Nos.: 850, 1050, 1250, 1450 and 1650. Another suitable example of a spray head or nozzle is a pressure swirl atomizing nozzle made by SeaquistPerfect Dispensing of Cary, Illinois under the Model No. DU3813.

Discharge nozzles can act as a fluid atomizing nozzle, using either a pressurized spray, or a dual fluid nozzle using air assist. Pressurized spray nozzles have an advantage of not requiring high pressure air to assist atomization of the treatment fluid. Special nozzle designs can be employed as well, for example utilizing a high voltage power supply to act as an electrostatic spray nozzle.

Suitable spray heads can be solitary nozzles or a compound nozzle containing more than one nozzle. In one preferred embodiment there are 4 spray heads housed within a side protrusion on each side of the device with each spray head comprising 4 individual spray nozzles that are mounted in a dome shaped housing. Nozzle design typically will be chosen in conjunction with the shell design. If no side protrusion or a thin side protrusion is desired, a nozzle providing a wider angle of spray is typically used to get broad coverage where there is a short distance to the garments to be treated. A wider protrusion distance can facilitate a nozzle with a slightly narrower angle of spray to achieve acceptable coverage.

Nozzle flow rates can vary depending on the number of nozzles utilized. Typically the nozzle flow rate times the number of nozzles times the spray time will produce the desired amount of benefit composition to be applied. In a preferred mode the total spray time is less than about 200 seconds, alternatively less than about 100 seconds, or alternatively less than about 10 seconds. In one non-limiting embodiment where there are a total of 8 compound nozzles of 4 individual nozzles each, the spray time utilizing a small pump and pressure swirl nozzles, is about 2 seconds with a total benefit composition sprayed of up to about 10 grams, alternatively up to about 25 grams, alternatively up to about 50 grams, alternatively up to about 100 grams. Those of skill in the art will understand that by increasing the number of spray nozzles in the device, the total device flow rate can be increased, for example one spray nozzle

can provide an increase of about 1 gram per second. In addition to the spray heads, the device can also comprise one or more ultrasonic nebulizers, such as those known in the art.

Optionally, the benefit composition may be heated prior to spraying. Pre-heating the benefit composition prior to spraying may be accomplished by any heating element such as a heating wire or coil, an infrared lamp, microwave heating, radiational heating or heating-means known to one of skill in the art.

FIG. 3 is a perspective view of extractable drawer **200** for use with a device in accordance with at least one embodiment of the present invention. The extractable drawer comprises a supporting member **230** such as in the form of a rod, pole or beam, attached to both said drawer face **210** and said optional rear face **220**. In one non-limiting embodiment, the extractable drawer comprises a single hanging member, in another non-limiting embodiment, multiple supporting members are provided, such as in the form of multiple supporting members. In another non-limiting embodiment, the device further comprises one or more fabric hanging members supported by the supporting member. The fabric hanging members may be removably attached to the supporting member by a hook, snap on fitment, or other suitable mechanism to allow the fabric hanging member to be supported on the supporting member while positioning the fabrics within the receiving region. In another non-limiting embodiment, the one or more fabric hanging members are permanently attached to the supporting member. In another non-limiting embodiment, the one or more fabric hanging members are hingedly attached to the supporting member.

As explained herein, the optional rear face can form a generally snug fit with the interior dimensions of the shell such that a user cannot access any components behind the rear face when the extractable drawer is fully extended in an open position. Those of skill in the art will understand that the rear face should not occupy the exact internal dimensions of the shell where wires, tubes, hoses, dispensing heads, vents, or other internal elements are required to run within the shell alongside the side walls or in the back of the shell. Further, where the device comprises one or more side protrusions, the side protrusions would also extend laterally beyond the dimensions of the rear face such that any dispensing heads contained within the side protrusion are not unduly contacted by the moving rear face. In one embodiment, where the back of the shell comprises one or more of said vents of said venting system, the rear face can be operably designed to include apertures to allow air passing through said vents to pass into the receiving

region of the extractable drawer. Further, the extractable drawer comprises a base **240**. The base can have the same width as the drawer face or a smaller width. In one embodiment, the base comprises a hole to allow exposure to any heating element provided below the extractable drawer, and/or a channel to facilitate heated air flow either by natural or forced draft convection.

FIG. 4 is a perspective view of a device in accordance with at least one non-limiting embodiment of the present invention. In this embodiment, the side protrusions **130** are shown having an arcoidal shape. Suitable shapes for the side protrusions include but are not limited to any prism shape, such as a rectangle, square, or other polygon (as shown in FIG. 6); or an arcoidal shape, such as a circle, oval, or ellipse. FIG. 4 is shown having a device depth **12** which is the depth of the device in a closed position. As shown in this embodiment, the device depth can be the sum of the depth of the drawer face and the shell. In another non-limited embodiment, where the drawer face **210** of the extractable drawer rests flush to the rest of the shell, the device depth is generally equal to the shell depth **120** (unless the outer surface of the drawer face further comprises any elements which extend outwards such as a drawer handle **213**.)

FIG. 5 is a frontal view of a device in accordance with at least one non-limiting embodiment of the present invention. The device of FIG. 5 is similar to the device of FIG. 4 except that FIG. 5 further comprises a base stand **800**. In embodiments comprising a base stand, the footprint width of the device is the larger of either the greatest width of the drawer face or shell, or the greatest width of the base stand. In this embodiment, the footprint width would be measured as the greatest width of the base stand.

FIG. 6 is a perspective view of a device in accordance with at least one embodiment of the present invention. FIG. 6 shows a side protrusion having a rectangular or quadrilateral shape such as a squared or rectangular prism shape **134**. FIG. 6 further comprises a second extractable drawer **500** comprising a second drawer face **510**.

In one non-limiting embodiment, the extractable drawer is recessed into the interior of the shell. A hinged outer shell door can be provided to further enclose the extractable drawer within the shell. Optionally, this outer shell door can include an aperture where the knob or handle of the extractable drawer is exposed such that a user can pull the knob or handle and in one single motion hingedly open the outer shell door and extract the extractable drawer. In one embodiment, the knob or handle protrudes out of the aperture in the outer shell door.

The device of the present invention preferably contains a source of a fabric treatment composition. In one embodiment, the source of fabric treatment composition comprises a reservoir **610** positioned in the second extractable drawer **500** or a reservoir **612** positioned in the upper portion of the shell. Where the reservoir is positioned in the second extractable drawer, the reservoir can be accessed by pulling out the second extractable drawer. Where the reservoir is positioned in the shell forming the upper extractable drawer, an opening in the shell can be provided to allow access to the reservoir. The reservoir for a fabric treatment composition is operably connected to said one or more dispensing heads provided within said device, wherein said one or more spray heads are oriented to dispense said fabric treatment composition towards said receiving region. Importantly, the reservoir can be a refillable or replaceable reservoir.

In another embodiment, said source of said fabric treatment composition comprises: a reservoir for a fabric treatment composition, operably connected to a plurality of dispensing heads provided within said device; a detached spray member; a fluid transport member operably connected to a building piping system; and a combination thereof. Suitable detached spray members include known hand spray products, such as FEBREZE[®] fabric spray, DOWNY[®] Wrinkle Release sprayers or any other commercially available spray apparatus, such as starch sprays or bottled perfume sprays, or aerosol can products, such as FEBREZE[®] Air Affects. Suitable detached spray member sizes include 12 oz. containers and 27 oz. containers. The detached spray member can be a bottle which can be provided separate from the device or can be removably attached to the device such as in a bottle stand. In one embodiment, where the user desires just to wet the fabric with water, the source of the fabric treatment composition can be provided from another device such as a laundry machine or a faucet in the home. Suitable sources of fabric treatment composition include fluid dispensing systems as disclosed in U.S. Publication No. 2010-0071777 published in the name of Smith *et al*, on March 25, 2010 and U.S. Application Serial No. 12/636,998 filed in the name of Smith *et al*, on December 18, 2009.

FIG. 7 is a frontal view of a device in accordance with at least one non-limiting embodiment of the present invention. This device is similar to the embodiment shown in FIG. 6 however, the side protrusions are shown having a concave curved interface **135** between the side protrusion **134** and the side wall. Further, FIG. 7 is supported atop an optional base stand **801**, said optional base stand creating a footprint width **827** which is greater than the drawer face

width **227**. The optional base stand provides increased stability against overturning especially in light of the footprint aspect ratio. In this embodiment, the greatest lateral width of the device is the width of the optional base stand **827** which is shown as being greater in width than the width of the portion of the shell forming the side extensions. Where the optional base stand is removed or not provided, the greatest lateral width would be the shell width **127**.

In one non-limiting embodiment the top of the device is a rounded. In one non-limiting embodiment, the rounded top comprises a surface which is not perfectly smooth and can be used to support a fabric laid thereon. By increasing the coefficient of friction of the rounded top, fabrics can be draped atop the machine. In another embodiment, the device comprises a button a user could push to release and/or at least partially eject the extractable drawer from the shell. This button can be a single activation trigger pulling the drawer in and turning the machine on for operation. The extractable drawer can be spring loaded such that it will automatically extend away from the shell when actuated. It is believed that by providing an extractable drawer which is connected to the hanging member, by the single motion of extending the extractable drawer, the hanging member is automatically extracted. Thus no additional step of accessing the interior of the device and/or pulling out a hanging rod is needed. Further, by automatically exposing the hanging member, there is no need for the user to touch or contact any interior contents of the device. The interior contents of the device are likely to form deposits and/or buildups of dust or any dried fabric treatment composition upon repeated use. By decreasing the amount of contact a user needs to make with the interior contents, the use of the device is simplified and becomes more hygienic and clean.

In another non-limiting embodiment, the cabinet may comprise a user interface which comprises the aggregate means by which users can interact with the device, including, for example, any device or computer program portion of the device. In various embodiments, the user interface may comprise an input, an output, or a combination thereof. The input allows the user to enter information into the device **10** to manipulate or control the operation of the appliance. The output allows the device **10** to produce effects for the benefit of the user. In various embodiments, the input and output may comprise visual, audio, and tactile devices. In one embodiment, the input may be configured as a touch keypad and the output may be configured as a display, light emitting indicator, and/or audible alarm.

In one non-limiting embodiment, the device further comprises one or more drains (not shown) to allow excess fabric treatment composition to drain out of the cabinet into an optional drain pan (not shown). The drain can be in the form of an aperture formed within the base of said extractable drawer and/or an aperture formed in the lower portions of the shell. In embodiments comprising a second extractable drawer, the drain pan can be positioned with the extractable drawer or below the second extractable drawer such that any excess fabric treatment composition which reaches the drain pan can evaporate similar to a drain pan in a conventional refrigerator or freezer.

FIG. 9 is a frontal view of a device in accordance with at least one non-limiting embodiment of the present invention. As shown in FIG. 9, the side walls of the shell can form a plurality of side protrusions **137**. Each of said protrusions preferably contains at least one dispensing head. By providing side protrusions throughout the height of the device, the dispensing heads can efficiently and quickly wet the entire fabric contained within the receiving region of the extractable drawer, on both sides of the fabric. Further, FIG. 9 shows an embodiment wherein the device comprises a base stand **803** which can be wheels or sleds to allow for easy movement and portability of the device.

FIG. 10 shows a frontal view of a device in accordance with the present invention wherein the device comprises an extractable drawer **200** which opens by extending the drawer in a vertical or upward direction away from the shell **100**. Suitable methods to extend the drawer away from the shell (or extract the drawer upwards) include spring loaded members provided within the device or chain driven or leveled mechanisms which can allow for automatic opening. In one non-limiting embodiment, the extractable drawer is pulled upwards manually. As shown in this figure, extractable drawer **200** comprises a drawer face **210** and has a greatest lateral width of the drawer face of the extractable drawer **227**. The device in this embodiment further comprises a greatest lateral width device of **127**.

FIG. 11 shows a perspective view of a device which also comprises an extractable drawer **200** which opens by extending the drawer in a vertical or upward direction away from the shell **100**. Expandable drawer **200** comprises a drawer face **210** having an outer surface **212**. As shown in this embodiment, extractable drawer **200** comprises a supporting member **230**. Where fabrics are hung off said supporting member in the receiving region, the fabrics will be

transported into the interior of the device when the extractable drawer is closed. The device further comprises a depth **12** and a height **125**.

FIG. 12 is a frontal view of a device in accordance with at least one non-limiting embodiment of the present invention having a passive heat management system. Shell **100** is shown containing two sheets in this embodiment, a first sheet **910** is shown on the left portion of the device and is not touching the interior surface of the shell. A second sheet **920** is shown adjacent to the interior surface on the right portion of the device. The sheets can have differing three dimensional thicknesses as shown in the figure. In this embodiment the sheets can be the same material and have the same sheet thickness but different three dimensional thicknesses. Alternatively, the sheets can be different in material and thickness.

FIG. 13 is a top view of a device in accordance with at least one non-limiting embodiment of the present invention having a passive heat management system. Shell **100** contains a first sheet **930** which is corrugated. In one non-limiting embodiment the corrugated sheet touches the interior of the side wall. In another non-limiting embodiment the corrugated sheet does not touch the interior of the side wall. Shell **100** also contains a second sheet which comprises three dimensional cones or apertures **945** formed from the body of the sheet **942**. The cones or apertures can touch the interior of the side wall or can be near it.

Additional optional elements include: one or more visible indicia provided on the exterior of the device to communicate the status of the device during operation; a sound indicator to communicate the status of the device during operation. In one non-limiting embodiment, the visible indicia comprises a countdown timer, a red/yellow/green status light system, blinking lights which can blink at different rates depending on the status of the operation, or any other light which is conventionally used with home appliances or devices. In another non-limiting embodiment, the sound indicator wherein the sound indicator is operably connected to a controller so the sound indicia can change depending on the stage; preferably below 70 dB.

In one non-limiting embodiment, while the device is in operation, the level of noise generated by the device during operation is less than 50 decibels at about 3150 Hz frequency, alternatively at about 4,000 Hz frequency, and alternatively at about 5,000 Hz frequency. Without intending to be bound by theory, it is believed that this level of noise is sufficiently

quiet so that it does not disturb any persons or pets which may be sleeping or resting during operation of the device. This has been found to be particularly important when the device is used in a bedroom or in a closet adjacent to or connected to a bedroom. It is believed that a human is typically sensitive to noises across the audible spectrum of 20 Hz to 20 kHz.

The device may be powered by a power source non-limiting examples of which include: a solar power member; plug in AC or DC power source; a battery; fuel cell, latent heat accumulator, and combinations thereof.

SUITABLE FABRIC HANGING MEMBERS

Fabrics can be placed in the receiving region of the fabric treatment device by any appropriate method known in the art. In one embodiment, one or more fabrics are hung on one or more fabric hanging members. Said fabric hanging members are removably or fixedly attached to said suspending member. In one embodiment, the suspending member is in the form of one or more bars, poles, ropes and so forth, which can be attached to the front face and/or rear face of the extractable drawer. (*See e.g.* FIG. 1 and FIG. 3.) In another embodiment, the suspending member extends from the drawer face of the extractable drawer. (*See e.g.* FIG. 10.) In one embodiment, the suspending member suspends more than one fabric hanging members (such as conventional clothing hangers or any other hangers disclosed below). Any suitable fabric hanging member can be used in accordance with the present invention. Preferably, the fabric hanger member is made of a material which is not susceptible to forming rust or melting or deforming within the device while in operation. Non-limiting examples of suitable fabric hanging members are described in EP Patent Nos. 812556, 670135 and 683999; DE 29713157; U.S. Patent Nos. 7,328,822, 6,964,360, 6,817,497, 5,511,701, 5,085,358 and 5,664,710; US Publication Nos. 2008/00616 and 2005/0023310; and JP 110572999.

In addition to providing a fabric hanging member within the device, in one embodiment, the device further comprises a method to apply tension to the fabrics within the cabinet such that wrinkles are reduced during operation of the device. The fabrics hung within the receiving region of the present device can also be weighted or stretched such that the fabric is under tension, to improve wrinkle reduction. Tensioning systems such as hanging weights and stretching devices are well known to those skilled in the art. *See e.g.* EP Pat. No. 587173; DE

Patent No. 4435672; and US Patent No. 5,344,054. The fabrics may be tensioned after placing them into the container and before starting the process or at the start of the process. This stretching or so-called tensioning of the fabric helps the relaxation of wrinkles during the process and provides a restoring force to the fabric to reestablish an unwrinkled orientation as the device operates.

Preferred stretching systems include weighted as well as lightweight compactable or retractable stretching systems, wherein the system comprises a tensioning device like a spring. The latter systems have the benefit of not adding extra weight to the cleaning and refreshing apparatus, along with the possibility of adjusting tensioning force and direction as required. Preferably, these systems are mounted inside the container at its bottom. One example of such a system is a roller blind that is conventionally used as a sun filter for cars and commercially available from Halfords. This system is a roller blind which can be extended or compacted by means of a roll-up spring mechanism. Only slight modification of this system is needed to adapt it to the tensioning of fabric. One preferred adaptation involves attaching the housing of this system at the bottom of the apparatus and providing one or more clamps at the other side so that the clamping and thus the stretching or tensioning of the fabric in the apparatus is obtained. The tension of the spring can also be adjusted to the desired stretching force for a given fabric. The size of the clamp can vary so that more than one clamp is attached to this system. Still, another variation involves having only one clamp which runs along or partly along the blind tensioning system located opposite the housing of the system.

In one embodiment, the hanging member and optional tensioning system are movable within said shell. By moving the hanging member and optional tensioning system, the receiving region with any fabrics contained therein can be moved from one side of the device to another, such as in a lateral direction. Moving the fabrics laterally allows for increased distance from the dispensing heads positioned on the interior of the opposite side wall and /or optional protrusion(s). Thus, in one embodiment, the fabrics are moved to one side of the interior of the device while the distribution of the fabric treatment composition is coordinated to emit from the opposite side of the device, for example wetting the front of the fabrics. Correspondingly, the fabrics can be moved to the other side of the device such that the other set of dispensing heads are triggered to wet the other side of the fabrics, such as the back of the fabrics. This increases the lateral distance between the fabric surface being wetted and the dispensing heads allowing

for better distribution. The moveable hanging member can be achieved by any mechanical system suitable for use, such as a chain driven system or a gear driven system.

FABRIC TREATMENT COMPOSITION

Any conventional liquid and/or fluid fabric treatment composition can be used as a fabric treatment composition without deviating from the present invention. Suitable fabric treatment compositions include any liquid or fluid composition which reduces and/or removes wrinkles, malodors, and/or delivers any other desirable fabric treatment benefits. Additional suitable fabric treatment compositions include perfumes and fragrances which can impart desirable odors upon the fabrics and or into the ambient air where the device is stored. Water, including purified water, tap water and the like are also suitable fabric treatment compositions.

Although the present device is preferably used for refreshing a fabric or garment, such as by reducing malodors and/or wrinkles, it is possible to use a composition which can be stain repellent and/or also assist in the removal of stains, soil, discolorations and/or other undesirable affects from the wearing and use of the fabrics.

In one non-limiting embodiment, the fabric treatment composition comprises water and optionally a member selected from the group consisting of surfactants, perfumes, preservatives, bleaches, auxiliary cleaning agents, shrinkage reducing compositions, organic solvents, antimicrobial agents, and mixtures thereof. Suitable fabric treatment compositions may include both volatile and non-volatile ingredients. Non-limiting examples of suitable organic solvents are glycol ethers, specifically, methoxy propoxy propanol, ethoxy propoxy propanol, propoxy propoxy propanol, butoxy propoxy propanol, butoxy propanol, ethanol, isopropanol, wrinkle removing agents, in-wear anti-wrinkling agents, semi-durable press agents, odor absorbing agents, volatile silicones and mixtures thereof. Non-limiting examples of fabric shrinkage reducing compositions that are suitable for use are selected from the group consisting of ethylene glycol, all isomers of propanediol, butanediol, pentanediol, hexanediol and mixtures thereof. In one non-limiting embodiment, the fabric shrinkage reducing compositions are selected from the group consisting of neopentyl glycol, polyethylene glycol, 1,2-propanediol, 1,3-butanediol, 1-octanol and mixtures thereof. Non-limiting examples of suitable surfactants include a nonionic surfactant, such as an ethoxylated alcohol or ethoxylated alkyl phenol, and is present at up to

about 2%, by weight of the fabric treatment composition. Non-limiting examples of auxiliary cleaning agents include cyclodextrins and dewrinkling agents, such as silicone containing compounds. Non-limiting examples of suitable anti-wrinkling agents include volatile silicones, some of which can be purchased from the Dow Corning Corporation. One such volatile silicone is D5 cyclomethicone decamethyl cyclopenta siloxane. Typical fabric treatment compositions herein can comprise at least about 80%, by weight, water, preferably at least about 90%, and more preferably at least about 95% water. Non-limiting examples of suitable fabric treatment compositions include those disclosed in U.S. Patent No. 6,726,186 issued to Gaaloul *et al.*

Another non-limiting example of a suitable fabric treatment composition is a polymer composition for improved dispensing and improved stability of wrinkle reducing composition disclosed in U.S. Patent No. 6,491,840 issued to Frankenbach *et al* and the aqueous wrinkle control composition disclosed in U.S. Patent No. 6,495,058 issued to Frankenbach *et al.*

In yet another non-limiting embodiment, suitable fabric treatment compositions are disclosed in U.S. Publication No. 2009/0038083 published in the name of Roselle *et al* on February 12, 2009. For example one suitable fabric treatment composition comprises a water soluble quaternary ammonium surfactant. Typical minimum levels of the water soluble quaternary agent included in the composition are at least about 0.01%, alternatively at least about 0.05%, or alternatively at least about 0.1% while typical maximum levels of water soluble quaternary agent are up to about 20%, alternatively less than about 10%, alternatively less than about 3% and generally in the range of about 0.2% to about 1.0%. A substantially water insoluble oil component or oil mix, may also be included wherein the oil components may have a clogP of >1. Typically the minimum levels of the oil component included in the composition are at least about 0.001%, alternatively at least about 0.005%, or alternatively about 0.01% while typical maximum levels of oil components are up to about 5.0%, alternatively less than about 3%, and generally in the range of about 0.05% to about 1%. Optional ingredients may also be included while the balance of the composition is water.

METHOD OF REFRESHING A FABRIC

A method of treating a fabric comprising placing a fabric into the receiving region of the device of claim 1; depositing a fabric treatment composition upon at least a portion of said

fabric; actuating said heating element; and venting said device. In one embodiment, the step of depositing said fabric treatment composition comprises dispensing the fabric treatment composition onto the fabrics, such as by spraying, vaporizing, or misting. In one embodiment, the step of actuating said heating element further comprises a step of heating the air within the device to at least about 80° C, alternatively at least about 70° C, alternatively at least about 50° C. Without intending to be bound by theory, it is believed that this application of heat not only helps dry the fabric but also may have odor removal and/or microbial control benefits. Further, where a fabric treatment composition is used which includes antimicrobial agents, the addition of heat may give surprising odor control and anti-microbial benefits to the fabric. In another embodiment, said method of treating said fabric is completed within about 15 minutes, alternatively within about 10 minutes, alternatively within about 8 minutes. In one embodiment, the method further comprises pressing a single button to turn on the device.

It should be understood that every maximum numerical limitation given throughout this specification includes every lower numerical limitation, as if such lower numerical limitations were expressly written herein. Every minimum numerical limitation given throughout this specification includes every higher numerical limitation, as if such higher numerical limitations were expressly written herein. Every numerical range given throughout this specification includes every narrower numerical range that falls within such broader numerical range, as if such narrower numerical ranges were all expressly written herein.

All parts, ratios, and percentages herein, in the Specification, Examples, and Claims, are by weight and all numerical limits are used with the normal degree of accuracy afforded by the art, unless otherwise specified.

The dimensions and values disclosed herein are not to be understood as being strictly limited to the exact numerical values recited. Instead, unless otherwise specified, each such dimension is intended to mean both the recited value and a functionally equivalent range surrounding that value. For example, a dimension disclosed as “40 mm” is intended to mean “about 40 mm”.

All documents cited in the DETAILED DESCRIPTION OF THE INVENTION are, in the relevant part, incorporated herein by reference; the citation of any document is not to be construed as an admission that it is prior art with respect to the present invention. To the extent

that any meaning or definition of a term or in this written document conflicts with any meaning or definition in a document incorporated by reference, the meaning or definition assigned to the term in this written document shall govern.

Except as otherwise noted, the articles "a," "an," and "the" mean "one or more."

All documents cited in the Detailed Description of the Invention are, in relevant part, incorporated herein by reference; the citation of any document is not to be construed as an admission that it is prior art with respect to the present invention. To the extent that any meaning or definition of a term in this document conflicts with any meaning or definition of the same term in a document incorporated by reference, the meaning or definition assigned to that term in this document shall govern.

While particular embodiments of the present invention have been illustrated and described, it would be obvious to those skilled in the art that various other changes and modifications can be made without departing from the spirit and scope of the invention. It is therefore intended to cover in the appended claims all such changes and modifications that are within the scope of this invention.

What is claimed is:

1. A device (10) for treating fabrics comprising: a cabinet, said cabinet comprising:
 - a. a shell (100) having two side walls and forming an opening; and
 - b. an extractable drawer (200) comprising:
 - i. a drawer face (210) comprising an outer surface (212); and
 - ii. a supporting member (230),wherein said drawer face (210) and said supporting member (230) form a receiving region adapted to operably support a fabric, and wherein said extractable drawer (200) is adapted to fit within said shell (100) and can be extracted through said opening of said shell (100);
 - c. a heating element (300) contained within said device (10);
 - d. a passive heat management system within the shell (100), said passive heat management system formed of a material having a thermal conductivity, measured at 25° C, of from 5 W/(mK) to 430 W/(mK) and a linear thermal expansion coefficient of from 2 to 100 ($\times 10^{-6}$ in/in-°F); and
 - e. an air flow path (400) positioned to direct air through said receiving region.
2. The device (10) according to claim 1, wherein the passive heat management system comprises at least one sheet (942) adjacent to at least one side wall of the shell (100).
3. The device (10) according to claims 1 or 2, wherein the passive heat management system comprises two sheets (942), wherein each sheet (942) is adjacent to one of the side wall of the shell (100).
4. The device (10) according to any of the preceding claims, wherein the sheet (942) is corrugated.
5. The device (10) according to any of the preceding claims, wherein the sheet (942) has a three dimensional thickness of the sheet (942) can be from 1 mm to 4 cm.

6. The device (10) according to any of the preceding claims, wherein the sheet (942) comprises one or more apertures, preferably wherein the apertured sheet (942) has an average aperture area of from 0.5 cm^2 to 9 cm^2 .
7. The device (10) according to any of the preceding claims, wherein the sheet (942) comprises aluminum, stainless steel or a mixture thereof.
8. The device (10) according to any of the preceding claims, wherein the sheet (942) comprises more than one layer.
9. The device (10) according to any of the preceding claims, wherein at least a portion of the sheet (942) is coated with zirconium, tin, chromium, titanium, fluoride, phosphates, hafnium, copolymers of vinylidene salts and acrylic/itaconic acids and mixtures thereof, preferably wherein at least a portion of the sheet (942) is coated with titanium.
10. The device (10) according to any of the preceding claims, wherein the coated portion of the sheet (942) is oriented towards the receiving region of the device (10).
11. The device (10) according to any of the preceding claims, wherein at least a portion of the sheet (942) has a reflective surface.
12. The device (10) according to any of the preceding claims, wherein said air flow path (400) comprises an air circulation member operably positioned to direct air through said air flow path (400) and an optional air filtering system.
13. The device (10) according to any of the preceding claims, wherein said heating element (300) comprises a heating wire or coil, an infrared lamp, a microwave heating element, and combinations thereof.
14. The device (10) according to any of the preceding claims, wherein the sheet (942) is generally planar, wherein the sheet has arcuate portions, or is a combination thereof.

1/8

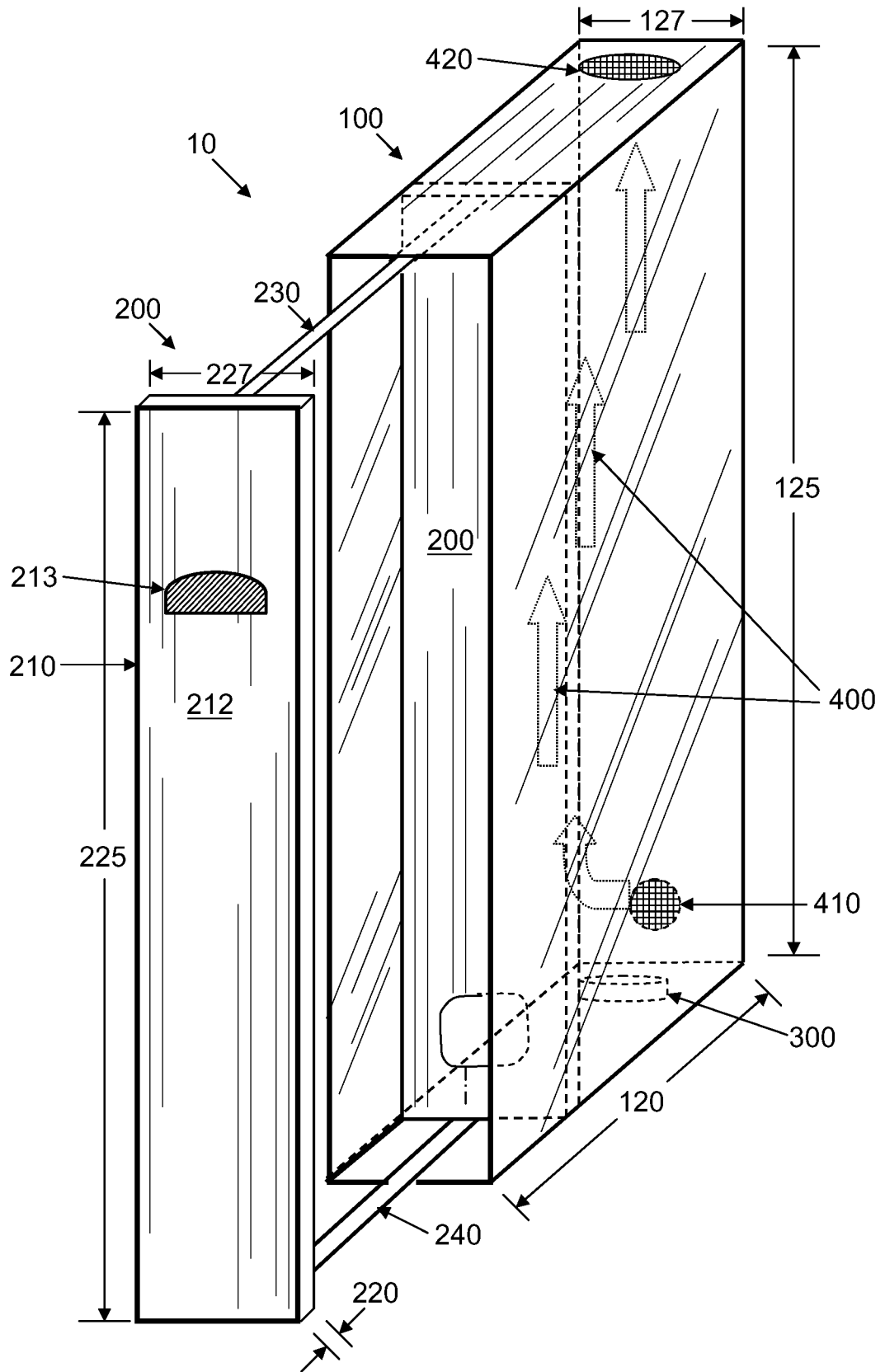

Fig. 1

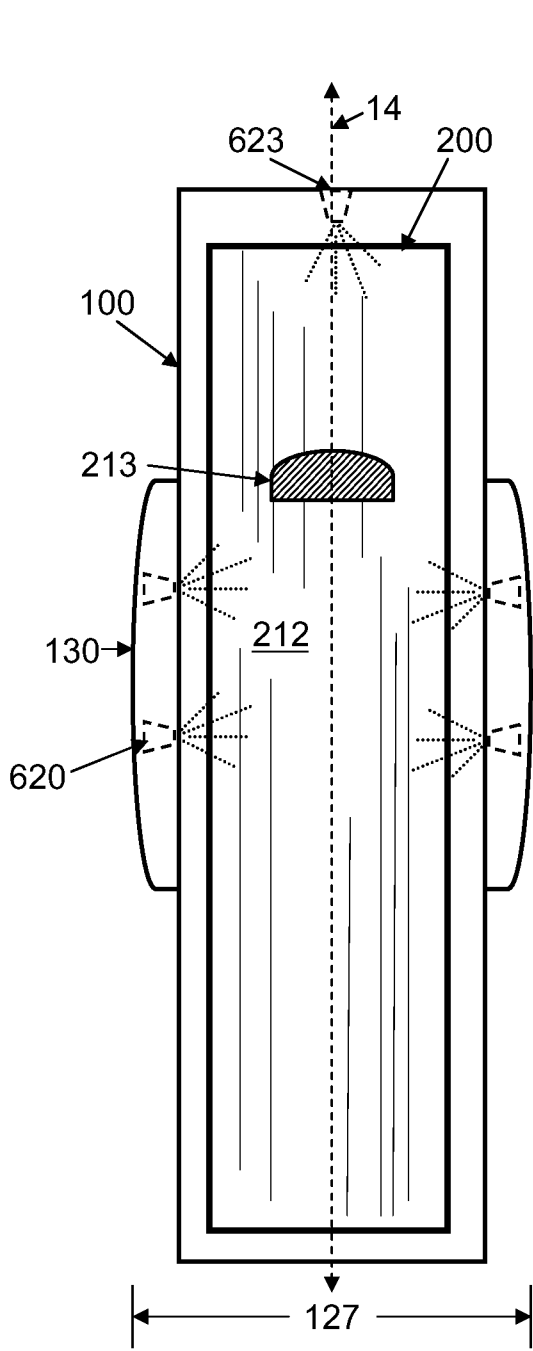

Fig. 2

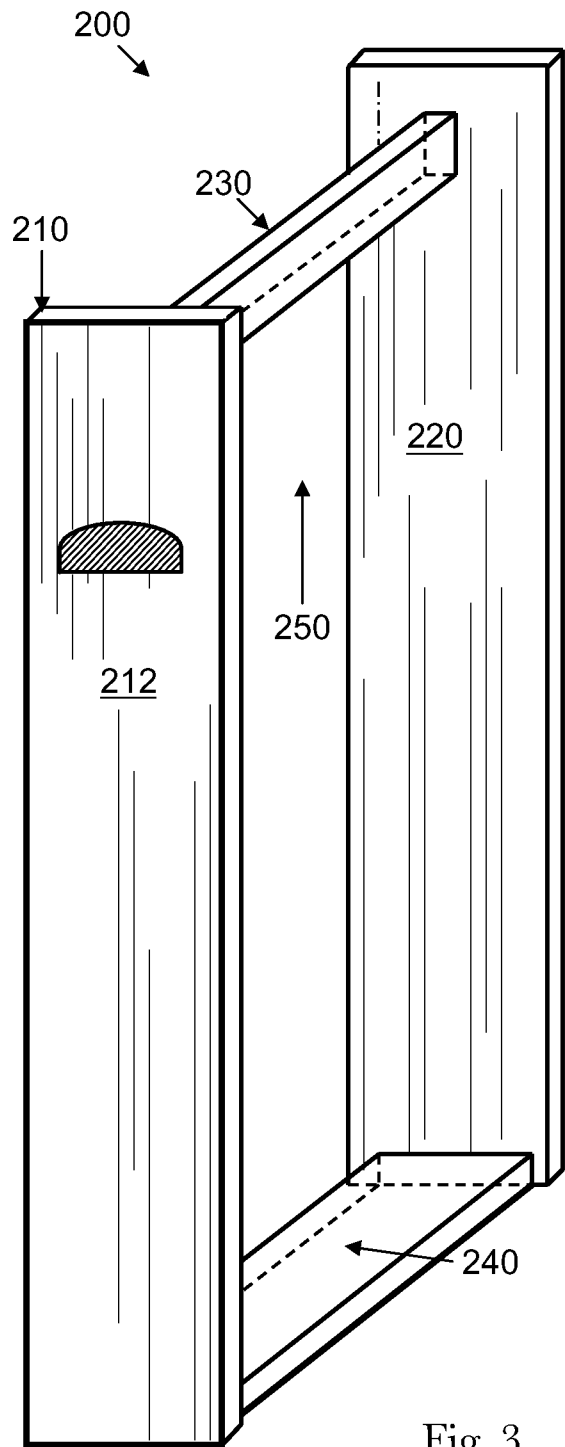

Fig. 3

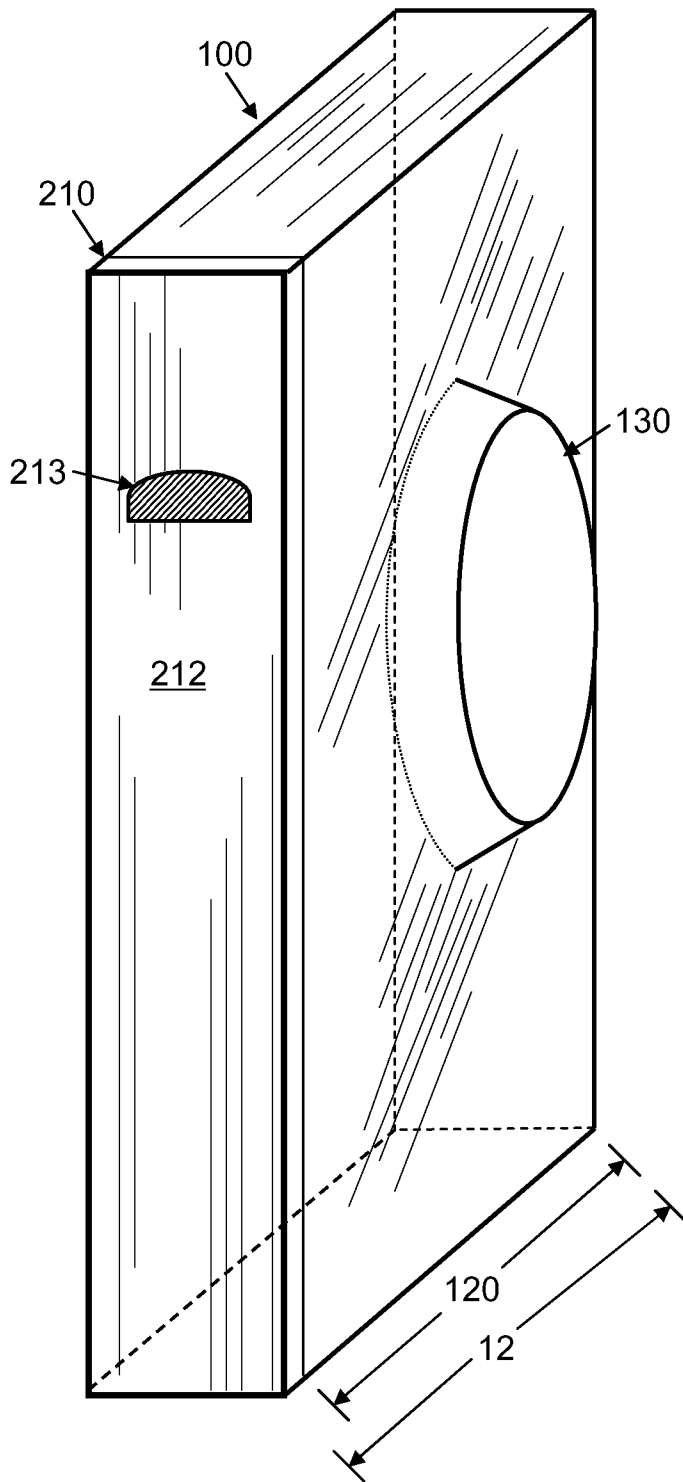

Fig. 4

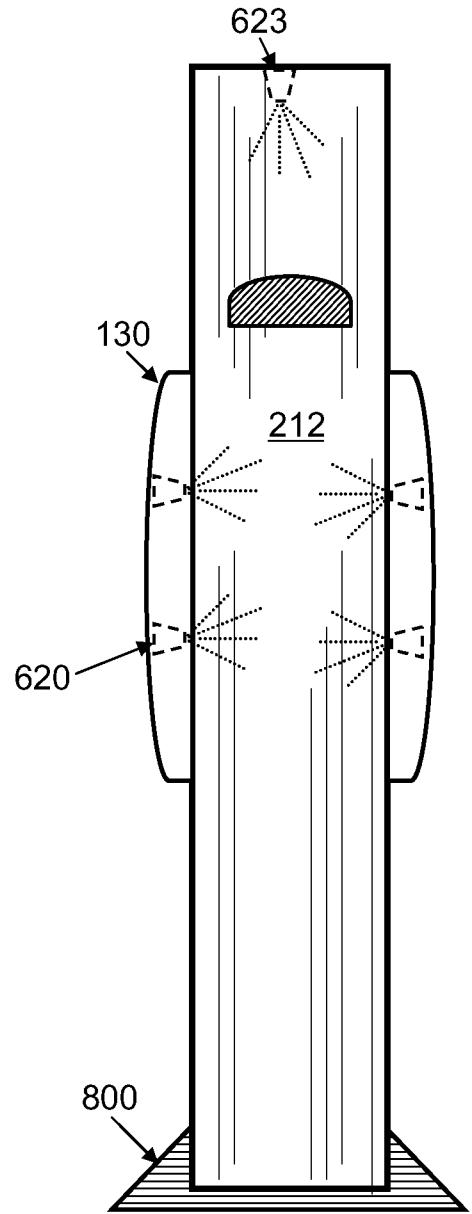

Fig. 5

4/8

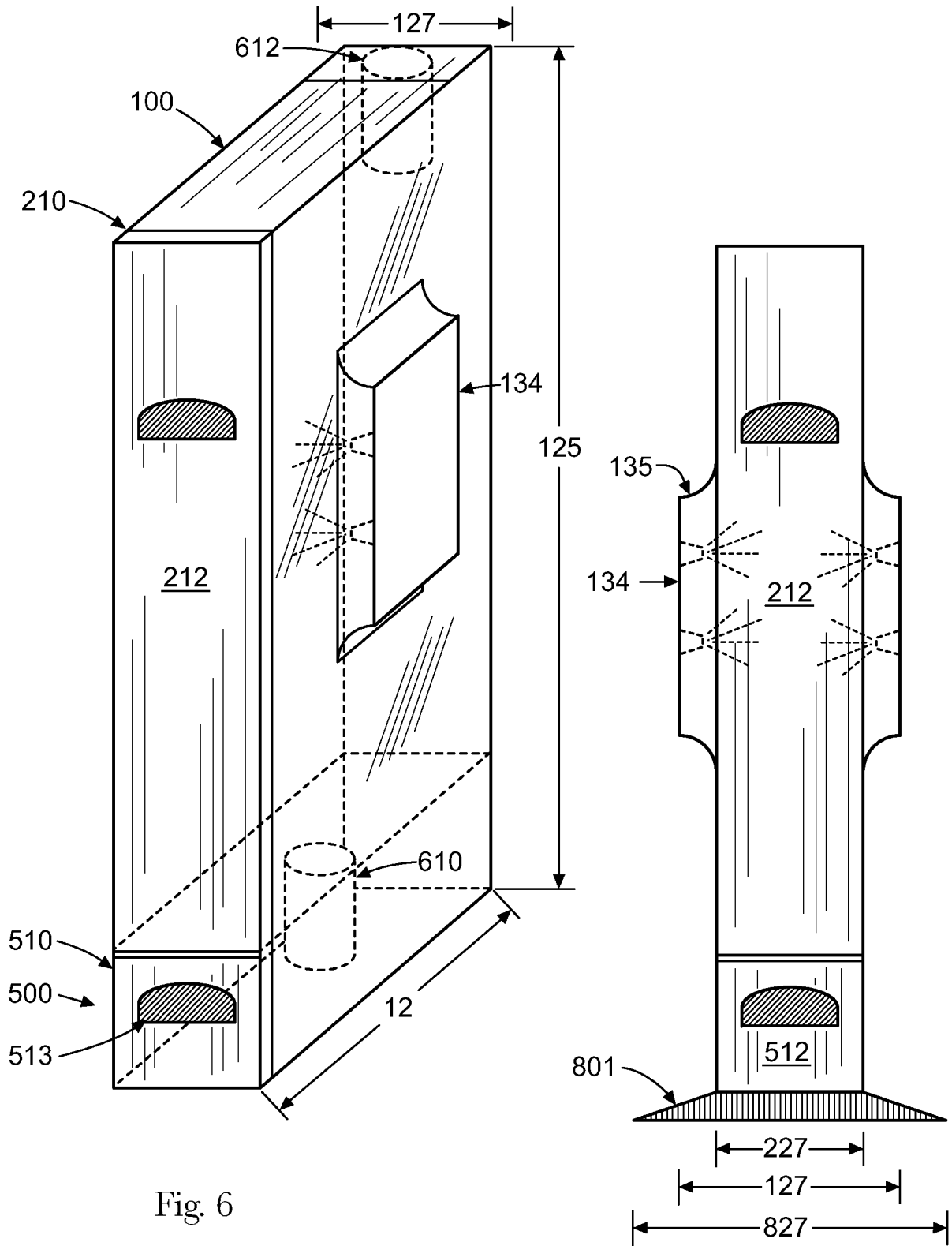

Fig. 6

Fig. 7

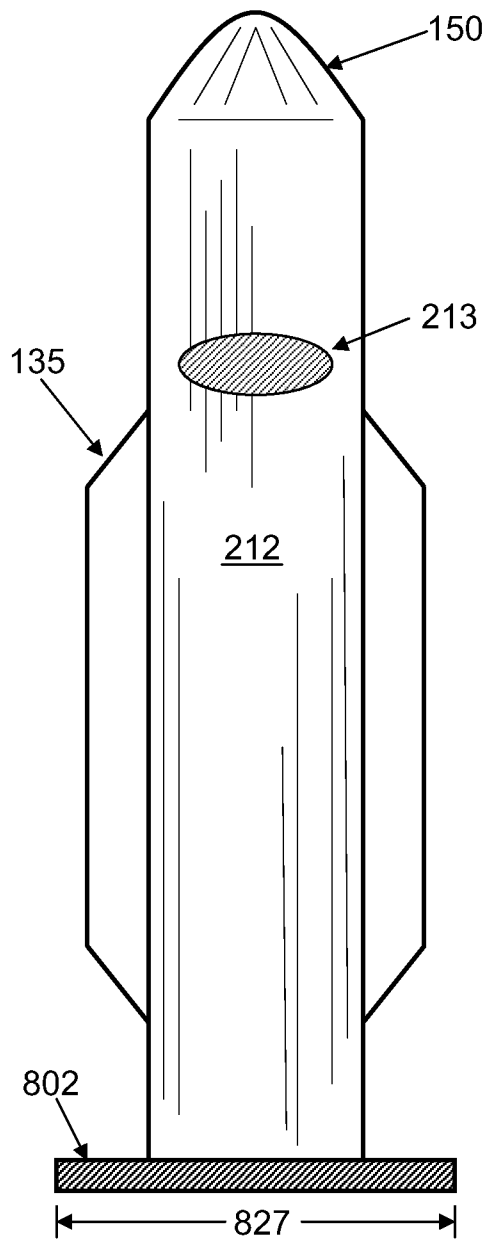

Fig. 8

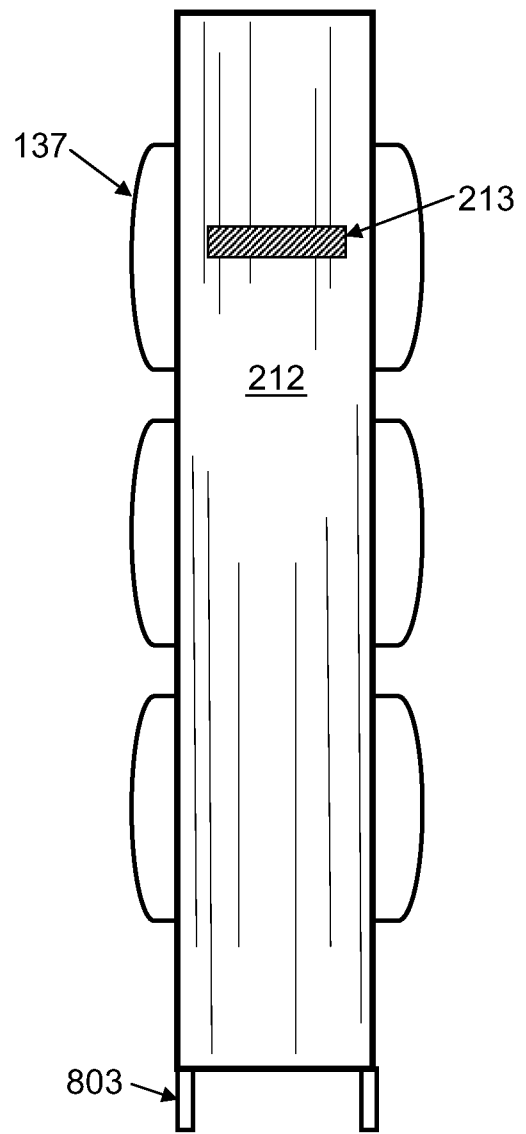

Fig. 9

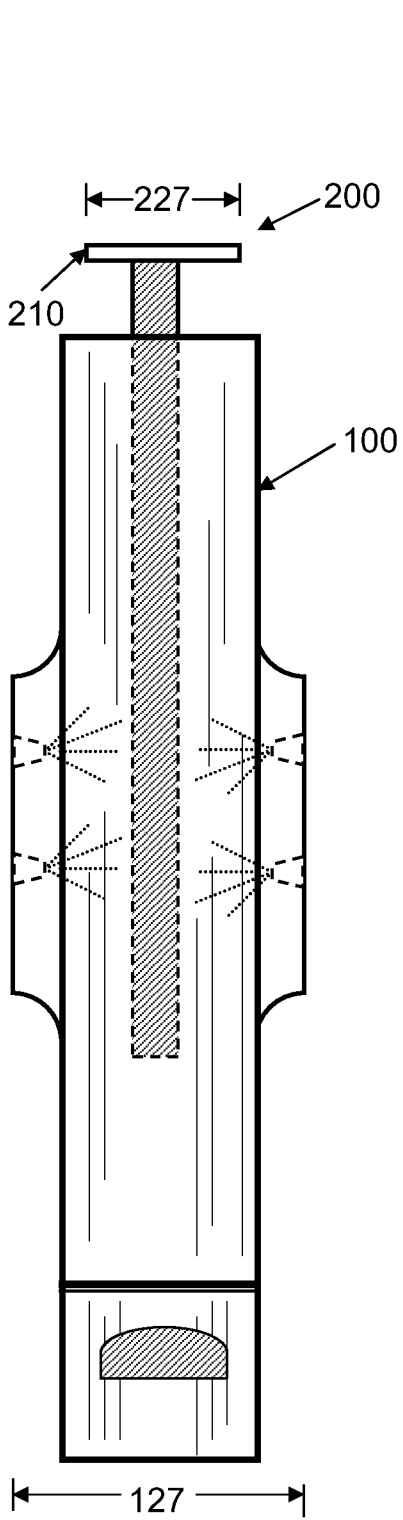

Fig. 10

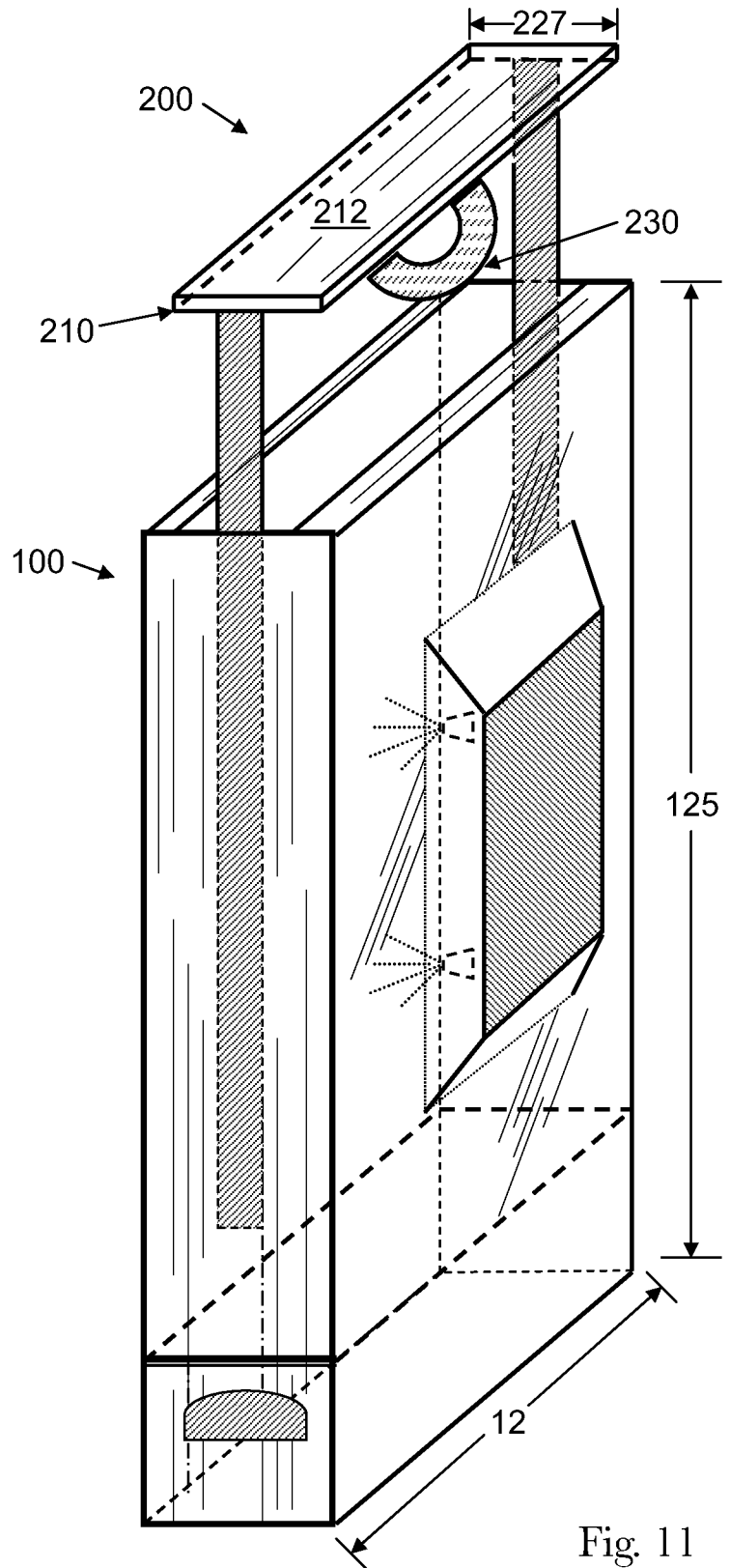

Fig. 11

7/8

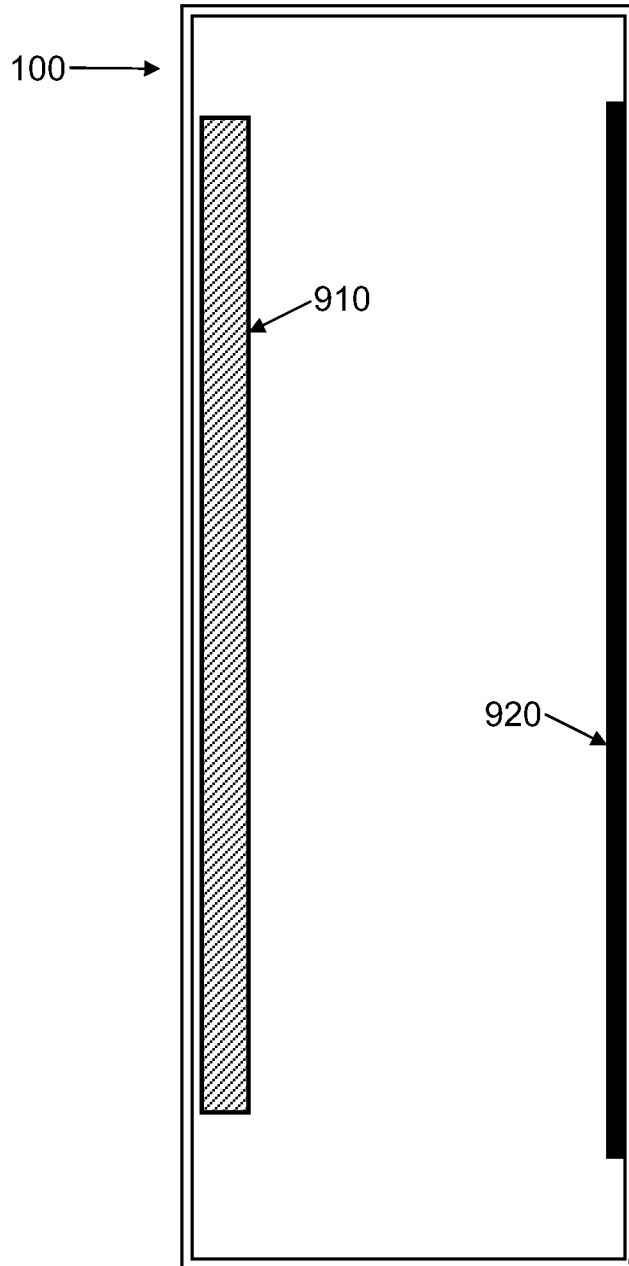

Fig. 12

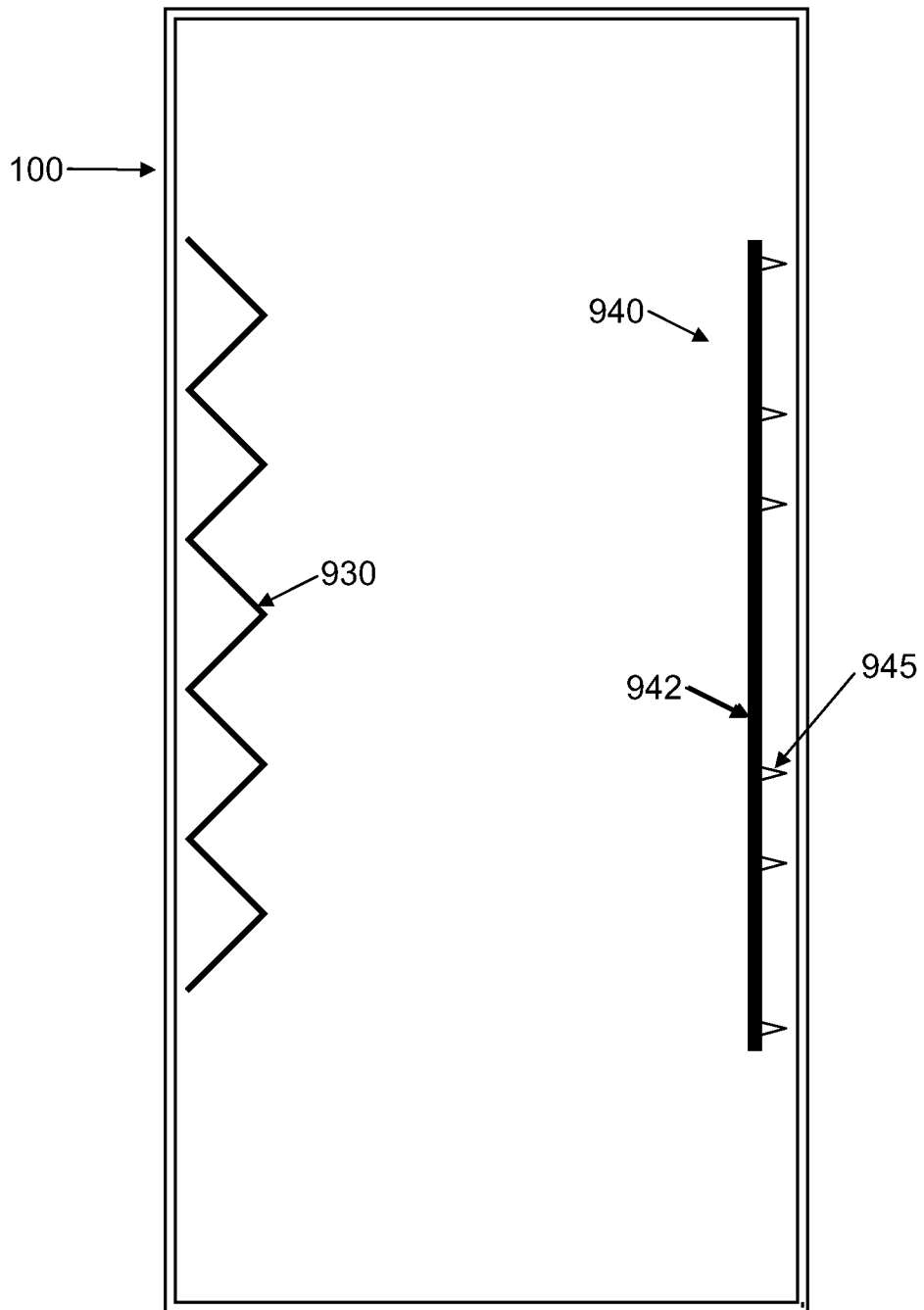

Fig. 13

INTERNATIONAL SEARCH REPORT

International application No
PCT/US2010/036818

A. CLASSIFICATION OF SUBJECT MATTER
INV. D06F33/02 D06F58/10
ADD.

According to International Patent Classification (IPC) or to both national classification and IPC

B. FIELDS SEARCHED

Minimum documentation searched (classification system followed by classification symbols)
D06F

Documentation searched other than minimum documentation to the extent that such documents are included in the fields searched

Electronic data base consulted during the international search (name of data base and, where practical, search terms used)

EPO-Internal

C. DOCUMENTS CONSIDERED TO BE RELEVANT

Category*	Citation of document, with indication, where appropriate, of the relevant passages	Relevant to claim No.
Y	WO 2009/064096 A2 (LG ELECTRONICS INC [KR]; KIM MYUNG SHIK [KR]; JEON HO IL [KR]; HAN JON) 22 May 2009 (2009-05-22) paragraph [0095] - paragraph [0097]; figure 2	1-14
Y	US 3 160 482 A (FOOTE ALLEN M) 8 December 1964 (1964-12-08) column 2, line 13 - column 3, line 34	1-14
Y	CN 201 024 339 Y (SHANGCHI LU [CN]) 20 February 2008 (2008-02-20) * abstract	1-3,5,8, 10,11,13
Y	CN 2 635 709 Y (LIU ZHIQIANG [CN]) 25 August 2004 (2004-08-25) * abstract	1,2,5, 10,11
	----- -/--	

Further documents are listed in the continuation of Box C.

See patent family annex.

* Special categories of cited documents :

- "A" document defining the general state of the art which is not considered to be of particular relevance
- "E" earlier document but published on or after the international filing date
- "L" document which may throw doubts on priority claim(s) or which is cited to establish the publication date of another citation or other special reason (as specified)
- "O" document referring to an oral disclosure, use, exhibition or other means
- "P" document published prior to the international filing date but later than the priority date claimed

- "T" later document published after the international filing date or priority date and not in conflict with the application but cited to understand the principle or theory underlying the invention
- "X" document of particular relevance; the claimed invention cannot be considered novel or cannot be considered to involve an inventive step when the document is taken alone
- "Y" document of particular relevance; the claimed invention cannot be considered to involve an inventive step when the document is combined with one or more other such documents, such combination being obvious to a person skilled in the art.
- "&" document member of the same patent family

Date of the actual completion of the international search

30 September 2010

Date of mailing of the international search report

08/10/2010

Name and mailing address of the ISA/

European Patent Office, P.B. 5818 Patentlaan 2
NL - 2280 HV Rijswijk
Tel. (+31-70) 340-2040,
Fax: (+31-70) 340-3016

Authorized officer

Kising, Axel

INTERNATIONAL SEARCH REPORT

International application No
PCT/US2010/036818

C(Continuation). DOCUMENTS CONSIDERED TO BE RELEVANT		
Category*	Citation of document, with indication, where appropriate, of the relevant passages	Relevant to claim No.
Y	WO 2007/132982 A1 (LG ELECTRONICS INC [KR]; HONG SOG-KIE [KR]; KIM DONG-WON [KR]) 22 November 2007 (2007-11-22) column 69 - column 78; figures 1,7	1,2,11
A	US 2005/120757 A1 (JACKSON W S [US]) 9 June 2005 (2005-06-09) paragraph [0021]; figure 1	1,12
A	US 4 682 424 A (IRVING ARLILLIAN [US]) 28 July 1987 (1987-07-28) figure 1	1
A	US 3 432 939 A (EICHHOLZ ARTHUR H) 18 March 1969 (1969-03-18) figures 1,4	1
A	US 6 263 591 B1 (LA PORTE VICTOR M [US]) 24 July 2001 (2001-07-24) column 1, line 21 - line 24; figure 1	1
A	US 2 618 076 A (HAASE MILLER ANNA) 18 November 1952 (1952-11-18) figure 1	1

INTERNATIONAL SEARCH REPORT

Information on patent family members

International application No

PCT/US2010/036818

Patent document cited in search report		Publication date	Patent family member(s)	Publication date
WO 2009064096	A2	22-05-2009	CN 101349001 A	21-01-2009
			DE 102008056697 A1	20-05-2009
			FR 2923498 A1	15-05-2009
			KR 20090048759 A	15-05-2009
			US 2009126421 A1	21-05-2009
US 3160482	A	08-12-1964	NONE	
CN 201024339	Y	20-02-2008	NONE	
CN 2635709	Y	25-08-2004	NONE	
WO 2007132982	A1	22-11-2007	CN 101415879 A	22-04-2009
			EP 2024551 A1	18-02-2009
			KR 20070110653 A	20-11-2007
			US 2009228156 A1	10-09-2009
US 2005120757	A1	09-06-2005	NONE	
US 4682424	A	28-07-1987	NONE	
US 3432939	A	18-03-1969	NONE	
US 6263591	B1	24-07-2001	CA 2332071 A1	25-07-2001
US 2618076	A	18-11-1952	NONE	