

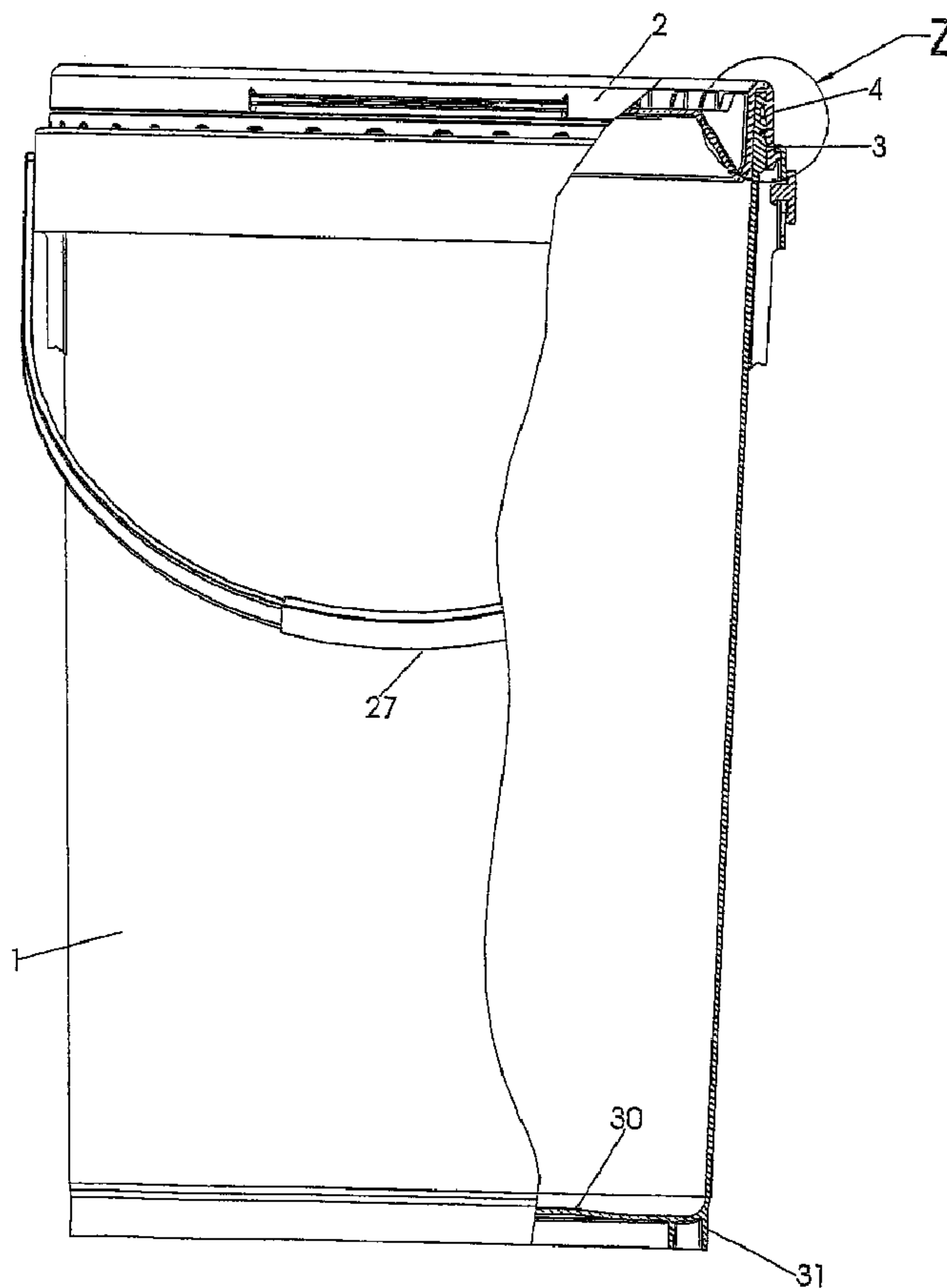

(86) Date de dépôt PCT/PCT Filing Date: 2003/10/13  
 (87) Date publication PCT/PCT Publication Date: 2004/06/03  
 (45) Date de délivrance/Issue Date: 2012/07/24  
 (85) Entrée phase nationale/National Entry: 2005/05/16  
 (86) N° demande PCT/PCT Application No.: EP 2003/011313  
 (87) N° publication PCT/PCT Publication No.: 2004/045978  
 (30) Priorités/Priorities: 2002/11/15 (DE102 53 371.7);  
 2002/12/20 (DE102 60 225.5)

(51) Cl.Int./Int.Cl. *B65D 43/02* (2006.01)  
 (72) Inventeurs/Inventors:  
 KELLERER, RICHARD, DE;  
 BARTUSEL, JENS, DE  
 (73) Propriétaire/Owner:  
 SCHOELLER ARCA SYSTEMS GMBH, DE  
 (74) Agent: CLARK WILSON LLP

(54) Titre : CONTENANT POUR LE TRANSPORT DE SUBSTANCES DANGEREUSES  
 (54) Title: CONTAINER FOR TRANSPORTING HAZARDOUS SUBSTANCES



(57) Abrégé/Abstract:

A container, in particular a plastic container, preferably in the form of a pail, having a lid for closing the container, said lid having a receiving area in which, when the container is in the closed state, the container lip limiting the container opening engages and is



(57) **Abrégé(suite)/Abstract(continued):**

held, mutually interacting catch members and sealing surfaces being provided in the receiving area of the lid and on the lip of the container opening, the catch members being configured such that when the container is in the closed state, the sealing surfaces are pressed together reliably to form seals, and, in particular, can only be released by destroying the lid and/or the rim.

**Abstract:**

A container, in particular a plastic container, preferably in the form of a pail, having a lid for closing the container, said lid having a receiving area in which, when the container is in the closed state, the container lip limiting the container opening engages and is held, mutually interacting catch members and sealing surfaces being provided in the receiving area of the lid and on the lip of the container opening, the catch members being configured such that when the container is in the closed state, the sealing surfaces are pressed together reliably to form seals, and, in particular, can only be released by destroying the lid and/or the rim.

**CONTAINER FOR TRANSPORTING HAZARDOUS SUBSTANCES****Field**

This invention relates to containers for safely transporting liquid or pasty hazardous substances. More particularly, this invention relates to such containers that have a safety seal.

**Background**

Containers for the safe transport of liquid or pasty hazardous substances have been known for a long time. One thing that these containers have in common is that they must be sufficiently leak-proof to prevent any escape of the transported hazardous substances. Secondly, they must be equipped with a closure that ensures safe closing of the container even under extreme loads. In particular, containers of this kind and their closures must withstand loads that may occur also in the event of an accident, for example falling of the container from a certain height.

Containers of this kind known from the prior art include, in particular, pails or drum-like containers whose lids are screwed on firmly to form a screw closure. To secure the closure, metal clips may be provided additionally, which press the lid onto the container or prevent the screw closure from unscrewing. There are also closure systems where the lid, after being fitted onto the container, is appropriately flanged to make the arrangement leak-proof. Systems are furthermore known in which the lid or closure is bonded or welded, or in which additional sealing films are bonded or welded.

The disadvantage common to all of these containers or closure systems is that they are complicated and difficult to handle; this is particularly problematic in view of the need for largely automated handling of such objects, including the closure process.

### **Summary**

The object of this invention is thus to provide a leak-proof and securely closable container that is suitable for the transport of liquid or pasty hazardous substances, both the production and handling of said container being uncomplicated and effective.

The container of the invention, which is preferably configured as a pail or in drum-like form, has a lid for closing the container, said lid having a receiving area in which, in the closed state, the lip of the container opening engages and is held there. In so far, the container of the invention is based on known containers.

Compared to the prior art, however, this invention pursues a completely different approach to solve the problem at hand. The container of the invention is based on the realization that by providing positively interconnectable catch members and correspondingly interacting sealing surfaces, it is possible to close a container securely and tightly. The use of positive connections formed by catch members and of appropriate sealing surfaces ensures that both handling and production are kept simple. Effective use of the container is thus ensured.

The positive connections formed by catch members are preferably configured such that the lid of the container can only be loosened if at least part of the lid or part of the container is destroyed. The user thus has a verifiable first-opener guarantee, since only a container that has never been opened is undamaged, whereas a container that has already been opened will have a damaged lid or be damaged itself.

According to a preferred embodiment of the container, the receiving area of the lid and the lip of the container opening, which engage on closure of the container, i.e. the catch members that form the positive connection, and the sealing surfaces are engineered such that putting on of the lid, i.e. closing of the container, is effected by way of translational movement of the lid relative to the container. It is particularly advantageous if the lid is simply pushed onto or clipped onto the container from above. This permits automatic closing of the container by a machine, since a translational movement or pushing or clipping on operations can easily be performed on a machine.

According to a preferred embodiment, at least two, preferably three or more pairs of catch members are provided in the receiving area of the lid and at the lip of the container opening, since a plurality of catch-member pairs makes it possible to secure the lid at several points and thus helps to close the container securely. The term "catch-member pair" does not refer here to just two catch members that lock positively together, but may also refer to a large number of catch members, which, however, on account of their similar configuration and identical mode of action, are deemed to be just one catch-member pair. This applies, for example, to catch members formed simply by a sub-division.

According to a preferred embodiment of the container, the at least two, preferably three or more catch-member pairs are engineered such that at least one of these catch-member pairs is configured differently to the other catch-member pairs in such manner that the movement necessary to disengage the catch-member pair differs from that for the other catch-member pairs. This means that not all the catch-member pairs can be disengaged at once by way of a single movement of part of the lid, that is, of the receiving area of the lid, or of the lip of the container opening. On the contrary, the different movements required to disengage the catch-member pairs in their entirety ensure that a complex movement is necessary. It has

proved particularly useful to provide at least two kinds of catch-member pairs, which require opposing movements to disengage the catch. A particularly interesting approach here, for example, is to necessitate a portion of the receiving area to move both outwards and inwards for purposes of opening. This measure, in particular, thus goes beyond that of the need for different, in particular opposing, movements to disengage circumferential catch members located on opposite sides. Here, it is much rather different catch-member pairs that are meant, which are located close by each other, for example, one above the other.

The provision of different kinds of catch-member pairs that differ in the different type of movement needed to disengage the catch has the additional advantage that in this way, with the members that form the positive connection, an adequate clamping action may also be generated for the sealing surfaces provided likewise in the receiving area of the lid and at the lip of the container opening. Even if the pressure of the sealing surfaces against each other is already effected by appropriate dimensioning of the lid and the container opening, the provision of different kinds of catch-member pairs, as described above, ensures an additional contact pressure that can be reliably upheld in many stress situations.

In addition to separately located sealing surfaces, it is of advantage to provide matching sealing surfaces on the catch members forming the positive connection, since, particularly where different kinds of catch-member pairs are used that necessitate movements in different directions in order to disengage the catch, mutual keying can be effected which results in the positively-locking catch members pressing against each other to a certain extent and thus forming sealing surfaces.

According to a preferred embodiment, additional seals may be provided in the receiving area of the lid and/or in the lip area of the container, particularly in the form of inserted or injected gaskets.

To realize the first-opening guarantee, as it is called, it may also be advantageous to provide a predetermined partition location in the receiving area of the lid and/or in the lip area of the container opening in order that those areas which guarantee a safe and unreleasable connection can be detached easily. In particular, it is of advantage here to provide -in the receiving area of the lid or on the lip of the container opening -a predetermined partition location which results in that part of the receiving area and/or of the lip being detached that has the differently functioning catch-member pair(s), as this kind of catch-member pair, in particular, may prevent the positive connection from being released.

According to a preferred embodiment, the cross-section of the receiving area of the lid is essentially V-shaped, the receiving area being open at the bottom in order to accommodate, from there, the lip of the container opening. The legs of the V-shaped receiving area enclose the lip of the container opening and hold it firmly, in positive-locking manner, by means of catch members. The sealing surfaces, meanwhile, are pressed firmly together, thus ensuring the sealing effect.

While it is of course possible to provide a large number of different combinations of detent hooks, latches, snap-in grooves etc., and appropriately configured sealing surfaces, the preferred embodiment of this invention has, in the V-shaped receiving area formed by an outer and an inner leg, two latches or detent hooks on the inside of the outer leg, said two latches or detent hooks interacting with two latches on the outside of the lip of the container opening. On its outside, the outer leg of the V-shaped receiving area has, in addition, a further detent hook that interacts with an undercut in the lip of the container opening, said undercut being provided in a double-walled portion of the lip, on the outer arm of the lip. By locating detent hooks or latches both on the inside and on the outside of the outer leg of the U-shaped receiving area, and configuring corresponding undercuts or catch members on the

lip area of the container opening, two different kinds of catch-member pairs are formed which differ in that the catch formed by the one kind of catch-member pair can be released by moving the outer leg outwards, whereas to release the catch formed by the other kind of catch-member pair, the outer leg must be moved inwards.

This simple configuration of catch-member pairs ensures, for one thing, that the lid can easily be put onto the container by a vertical downward movement. For another, this triple locking system ensures that the lid is fitted securely on the container. The different kind of catch-member pairs with the opposing opening movements ensures additionally that the lid cannot be removed without incurring damage.

To permit easy opening of the container without the use of any particular specialty tools, and to ensure that the lid is easily put on, a constriction is engineered in the outer leg of the U-shaped receiving area, so that in this area an integral hinge, or film hinge, forms, which constitutes a lower segment of the outer leg. One effect of this film hinge is that the lower segment of the outer leg can perform the movements necessary to get past the latches or detent hooks and the undercuts during closure of the container, that is, when the lid is put on. The film hinge, i.e. the constriction, additionally offers the possibility of detaching the lower segment by simply cutting along the film hinge with a cutting tool such as a knife. Since the receiving-area catch members for two different catch-member pairs are preferably provided in the lower segment of the outer leg, only one catch remains after detachment of the lower segment. This last catch may be released via a slight movement of the outer leg of the receiving area. This single remaining catch permits continued use and renewed closure of the container after it has first been opened, although it does not provide for secure closure with a first-opening guarantee. This single remaining catch also permits continued use and

- 7 -

re-closure of the container after it has first been opened, although secure closure with a first-opening guarantee is no longer ensured.

To permit uniform closure of the container, it is preferable if the catch members or catch-member pairs are located circumferentially around the container opening and lid; interruption or sub-division of a catch member by recesses, lands, etc. may result in the formation of a corresponding plurality of catch members, although, as defined in this invention, the purpose of uniform closure and treatment as one catch member or two catch members making up one catch-member pair is upheld.

Thanks to the measures described above, standard materials can be used for the container of the invention, without the need for special measures. Polyolefin-based plastics are preferred, in particular polyethylene and polypropylene. The sealing aids preferably used in addition need not fulfill any special requirements either regarding the choice of material, although, depending on the application in question, special requirements regarding the choice of material may exist. Along the dimensioning of the components, for example the wall thicknesses, must be adjusted to suit the application in order to withstand the necessary forces also in the case of exceptional loads, caused, for example, by accidents.

#### **Brief Description of the Drawings**

Further advantages, characteristics and features of this invention become clear from the following detailed description of an embodiment and the attached drawings. The figures are purely schematic.

Fig. 1 shows a partially cut-away side view of a container with its lid on;

Fig. 2 shows details of Figure 1 at various stages of closure (Figs, 2a, 2b and 2c);

- 8 -

Fig. 3 shows a cross-sectional view along the line D -D of Fig. 2b;

Fig. 4 shows a cross-sectional view along the line D -D of Fig. 2c;

Fig. 5 shows a perspective view of the container with its lid on;

Fig. 6 shows a perspective partial view of the container with its lid off;

Fig. 7 shows two containers stacked one inside the other;

Fig. 8 shows a transverse view (Fig. 8a) of two lids stacked on top of the other, and details (Fig. 8b) of Fig. 8a; and

Fig. 9 shows a top view of the container lid.

### **Detailed Description**

Fig. 1 shows a partially cut-away side view of a closed container 1 according to the invention, that is, with its lid 2 on. In the embodiment shown, the container 1 is in the form of a pail to which, to facilitate carrying, a rotatable handle 27 is attached.

As can be seen in the partially cut-away section of Fig. 1, the container 1 has a slightly inward-arching bottom 30 that has supporting feet 31 at its outer edge; there is thus a small space between the bottom 30 and the surface on which the pail stands. The container 1 furthermore has a slightly conical, albeit essentially cylindrical, outer shape, so that empty containers can be nested.

Figures 2a to 2c show details of the cutaway section, with the receiving area 4 and the lip 3 of the container opening, at various stages of closure of the container 1.

In Figure 2a, the container is still completely open; the lid 2 is resting lightly on the container opening, that is, on the lip 3 of the container opening. As is clearly evident in this

detailed view, the receiving area 4 at the periphery of the lid 2 is essentially V-shaped, with the receiving area open at the bottom so as to accommodate from there the element 9 of the lip 3 of the container opening. The receiving area 4 thus has two legs 5 and 6, namely an outer leg 5 and an inner leg 6, which are interconnected in the connecting area 7 at the foot of the U. The inner part of the lid 2 is connected via the lip connection 22 with the receiving area 4; the lip connection 22 forms an opposing V with the inner leg 6 of the receiving area 4, so that the inner part 32 of the lid 2 is located at the level of the upper part of the receiving area 4. The receiving area 4 in the embodiment shown forms a circumferential stacking edge, so that closed containers 1 can be stacked one above the other. Any shifting relative to one another is largely prevented by the receiving area 4.

On the inside of the outer leg 5 of the receiving area 4, two latches 12 and 13 are provided, while on the outside of the outer leg 5, almost at the bottom thereof, a detent hook 14 is engineered. The latches 12 and 13 and the detent hook 14 are spaced at approximately equal distances along the outer leg 5. In the immediate vicinity of the latch 13, in the area between the latch 12 and the latch 13, a constriction is provided in the outer leg 5 of the V-shaped receiving area 4, so that an integral hinge 15, or film hinge 15, forms; at the same time, on the inside of the outer leg 15, immediately adjacent to the latch 13, a groove 20 is engineered.

The side of the inner leg 6 that is opposite to the inside of the outer leg 5 is engineered as a smooth sealing surface; this sealing surface is angled somewhat relative to the vertical.

Directly in the area 7 connecting the legs 5 and 6 of the U-shaped receiving area 4, in the curvature 29 of the U-shaped receiving area, space is provided for accommodating a gasket that is not shown.

At its container opening, container 1 has a lip that is double-walled in the lower portion. In this lower portion of the lip 3 of the container 1 there is, in addition to the inner element 9, also an outer element 8 that forms the double wall. The lip 3 of the container 1 is thus made up of two sections, namely an upper, first section in which the lip 3 comprises the element 9 and is single-walled, and a lower, second section in which the lip 3 comprises the outer element 8 and the inner element 9, making it double-walled. In the first, upper section of the lip 3 of the container 1, on the outside of the element 9, two detent hooks 10 and 11 are provided which, in cross-section, are configured essentially as almost triangular projections. The second, lower section of the lip 3 of the container 1 has openings 25 at the top. At the same time, the outer element 8 with the edge of the opening 25 forms an undercut 21.

On the inside of the inner element 9 of the lip 3 of the container 1, a smooth, planar sealing surface 17 is engineered, which matches the sealing surface 16 of the receiving area 4 of the lid.

The closing process is shown in Figs. 2b and 2c. Figure 2b shows that on closure of the container 1 with the lid 2, the element 9 is inserted into the U-shaped receiving area 4, with the latch 13 first sliding past the detent hook 10, while the lower end of the outer leg 5 with the detent hook 14 is introduced into the opening 25 of the double-walled section of the lip 3 of the container 1.

As the container 1 is closed further with the lid 2, as shown in Fig. 2c, the latch 12 also slides past the detent hook 10, and the latch 13 past the second detent hook 11. The latches 12 and 13 and the detent hooks 10 and 11 are configured such that they have complementary inclined surfaces which permit the latches to slide past the hooks in the direction of closure, whereas they are prevented from sliding back again by the positive-locking catch. At the same time, on complete closure, the lower part of the outer leg 5 is accommodated

- 11 -

completely in the double-walled section of the lip 3, the detent hook 14 coming to rest beneath the undercut 21. It becomes evident here that on closure, the lower segment 33 of the outer leg 5 is on the one hand pressed outwards by the detent hook 11, whereas, on the other hand, the lower segment 33 of the outer leg 5 has to be bent inwards by the detent hook 14 in order for it to be inserted into the opening 25 of the double-walled lip 3. This is made possible, in particular, also by the configuration of the film hinge 15, which permits a different movement of the lower segment 33 depending on the stage of closing with the lid 2.

In the completely closed state, it is evident that for one, the latches 12 and 13 form positive connections with the detent hooks 10 and 11, while for another, the detent hook 14 forms a positive connection with the undercut 21. To release all three catch-member pairs, it would be necessary to move the outer leg 5 outwards to disengage the catch-member pairs 12 and 10 and 11 and 13, while an inward movement would be necessary to disengage the catch-member pair 14 and 21. As a result of the inclined surface provided by latch 13, which is supported on the detent hook 11, the catch effect of the catch-member pair 14 and 21 is further reinforced, as a lever effect acts in the direction of the catch position. It is therefore impossible to release the catch mechanism without destroying the receiving area 4, i.e. without cutting or detaching the lower segment 33 along the film hinge 15. Only when the lower segment 33 has been detached by cutting along the film hinge can the still-remaining catch formed by catch-member pair 12 and 10 be released. This has the added advantage that after the container has been opened the first time, which is visible to everyone due to the lower segment 33 remaining in the double-walled section of the lip, the container is still suitable for continued use and can be closed again.

Besides the formation of the catch-member pairs, a seal is generated on closure of the container due to the sealing surfaces 16 and 17 coming into contact, in particular, being squeezed together by appropriate adjustment of the dimensions of the lid 2 to those of the container 1 or the lip 3 of the container, and to the appropriate configuration of the catch mechanism between the receiving area 4 and the lip 3. In addition, the catch-member pairs, in particular the catch-member pair 12 and 10, also press sealing surfaces together, in this case the sealing surfaces 18 and 19, as shown in Fig. 2c. In the curvature zone 29 of the u-shaped receiving area an additional gasket that is not shown may be included, which is pressed by the upper end of element 9 against the connecting area 7 of the receiving area 4, thus producing an additional sealing effect.

As is also evident from Fig. 2c, the positive connection formed by the catch-member pair 13, 11 is further reinforced by a groove 20 engineered on the inside at the film hinge 15, into which groove the detent hook 11 can engage additionally. Figures 3 and 4 show, in cross-section, details from Figs. 2d and 2c, in each case along the line D-D. Figures 3 and 4 show how the element 9 engages between the outer leg 5 and the inner leg 6 on closure of the container 1. The cut views make it clear that both between the outer element 8 and the inner element 9 of the lip 3 and between the inner leg 6 and the lip connection 22 of the lid 2, partitions 23 and reinforcing walls 24 are provided, so that the second, lower, double-walled section of the lip 3 has openings 25 at the top that are essentially rectangular in cross-section. The lower area of the outer leg 5 is accordingly provided with complementary recesses into which the partitions 23 can engage in the closed state.

Figures 3 and 4, like Figure 2c, show part of the handle 27, which is likewise hinged in the double-walled portion of the lip 3.

Fig. 5 shows a perspective view of the container 1 with its lid 2 on it. This perspective view shows especially well how the handle 27 is rotatably hinged to the double-walled portion of the lip 3, in particular to the outer element 8.

The partitions 23, the reinforcing walls 24 and the openings 25 can also be seen very clearly in this projection. Figure 5 also shows the configuration of the stacking supports 26, which are located on the outside of the container 1, underneath the lip 3, in the vicinity of the hinging points for the handle 27. Figure 7 shows more clearly how the stacking supports work.

The lid 2 also has a pull means 28 attached to it, with which the lid 2 may be removed after the lower segment 33 of the outer leg 5 of the receiving area 4 (as shown above) has been detached. Figure 6 likewise shows a perspective view of part of the container 1 and of a lid 2 which has been removed therefrom. It is additionally evident from this projection that the outer leg 5 of the receiving area 4, at the lower end of which leg the detent hook 14 is provided, has a plurality of recesses 34 so that the outer leg 5 can engage the openings 25 and the partitions 23 have room in the area of the recesses 34.

Figure 7 shows, in a partially cut-away side view, two containers 1 and 1' stacked one inside the other. It becomes clear here how the stacking supports 26 and 26' work, which, when the containers are nested, rest on the upper edge of the element 9. This prevents the nested pails from jamming and ensures a defined load distribution. The side view illustrated in Figure 7 also shows clearly that the detent hooks 10 and 11 are engineered as circumferential ridges on the lip 3, that is, on the element 9.

As is evident from Figures 8a and 8b, not only the containers can be nested, but also the lids, as shown in Figure 8a. As illustrated in the detailed drawing of Figure 8b, the

- 14 -

connecting area 7 of the receiving area 4 forms a circumferential stacking rim into which the lower end of the inner leg 6 of the lid 2' positioned above can engage. In the cross-sectional view illustrated in Figures 8a and 8b, however, a reinforcing wall 23 prevents the inner leg 6 from being clearly apparent. The outer leg 5 is dimensioned such that the lower end of the leg 5 with the detent hook 14 is somewhat shorter than the lower end of the inner leg 6, so that the outer leg 5 ends above the connecting area 7 of a lid 2 positioned underneath.

Figure 9 shows, in a top view of the lid 2, the uniform subdivision of the perimeter of the lid 2 with the receiving area 4 by the reinforcing walls 24 and the recesses 34 and detent hooks 14. Although, of course, a large number of detent hooks are formed around the perimeter by the recesses 34, this plurality of detent hooks 14 is to be understood for the purpose of this application as one catch member, since, in particular, all the detent hooks 14 interact with the circumferential undercut 21 and therefore form one catch-member pair. By analogy, of course, and in the meaning of the term as it is used here, one catch-member pair can also be formed from a large number of detent hooks and latches.

**Claims**

1. A container in the form of a pail having an opening and a lip that limits said opening, and a lid for closing the container opening, said lid having a U-shaped receiving area, which is formed by an outer leg and an inner leg and engages and holds said lip when said container is in a closed state,
 

characterized in that at least two mutually interacting catch member pairs are provided, each of the at least two catch member pairs having a first catch member straight-lined on said outer leg of said U-shaped receiving area of said lid and a second catch member on said lip of said container opening, and

said receiving area and said catch member pairs are configured such that, when said container is in said closed state, sealing surfaces provided on said catch member pairs and on said outer and inner leg of said receiving area are pressed together reliably to form seals,

wherein at least one of the at least two catch member pairs (hereinafter, the at least one oppositely functioning catch member pair) is configured so as to release by way of an opposite movement to that required to disengage at least one other of the at least two catch member pairs, so that in order to release all of the at least two catch member pairs, at least part of at least one of the receiving area and of the lip must be moved in opposite directions and in that the sealing surfaces are pressed together along a direction of closure by forces exerted by the at least two catch member pairs,

wherein at least one of the receiving area of the lid and the lip of the container opening has a predetermined partition location for detachment of a lower segment, which comprises at least one catch member of the at least one oppositely functioning catch member pair, so that only the catch member pairs that are not the at least one oppositely functioning catch member pair (collectively, the identically functioning catch member pairs) remain, in order to permit opening of the container closed with the lid, and

wherein the predetermined partition location forms an integral hinge, which permits a different movement of the lower segment depending on the stage of closing with the lid.
2. The container of claim 1, characterized in that the receiving area of the lid and the lip of the container opening are operable to close the container with the lid by a translational movement, by pushing or clipping the lid onto the container from above.
3. The container of claim 1, wherein the lid can only be disengaged from the container by destroying at least one of the lip and the lid.
4. A container according to any one of claims 1 to 3, characterized in that the sealing surfaces are provided separately from the catch members or on the catch members.
5. A container according to any one of claims 1 to 4, characterized in that at least one seal is provided in the receiving area or on the lip of the container opening, and the at least one seal is in the form of inserted or injected gaskets.

6. A container according to any one of claims 1 to 5, characterized in that the cross-section of the receiving area is U-shaped, the lip of the container opening being at least partially, in a first section, straight in cross-section and is accommodated between the legs of the U-shaped receiving area, and at least one of (a) detent hooks, (b) latches, and (c) engagement grooves, that interlock on closure are provided on an inner side of the outer leg, and on an opposite first side of the first section of the lip, and an inner side of the inner leg and on an opposite second side of the first section of the lip of the container opening provide at least some of the sealing surfaces.
7. The container of claim 6, wherein the detent hooks include at least two detent hooks on the inner side of the outer leg of the receiving area and at least one detent hook on an outer side of the outer leg.
8. The container of claim 6 or 7, characterized in that the lip of the container opening is double-walled in a second section extending over a portion of the lip insertable into the receiving area, the outer leg of the receiving area engaging at least partially in a space between two walls of the lip.
9. The container of claim 8, characterized in that an outer element in the second section has an undercut or a catch member, which interacts with the detent hook on the outer side of the outer leg of the receiving area as the at least one oppositely functioning catch member pair.
10. A container according to any one of claims 6 to 9, characterized in that the predetermined partition location is on the outer leg of the receiving area of the lid and the hinge is formed as a film hinge partable with a cutting tool.
11. A container according to any one of claims 6 to 10, characterized in that in a connecting area of the legs of the receiving area, a gasket is provided, which, when the container is in the closed state, is pressed into the receiving area by an upper end of the lip of the container opening.
12. A container according to any one of claims 1 to 11, characterized in that the catch member pairs are arranged as circumferential hooks or latches on the lip of the container opening or on the receiving area.
13. A container according to any one of claims 1 to 12, characterized in that the container with the lid is securely and tightly closed at inside pressures of up to 1 bar.
14. A container according to any one of claims 1 to 13, characterized in that the container is plastic.

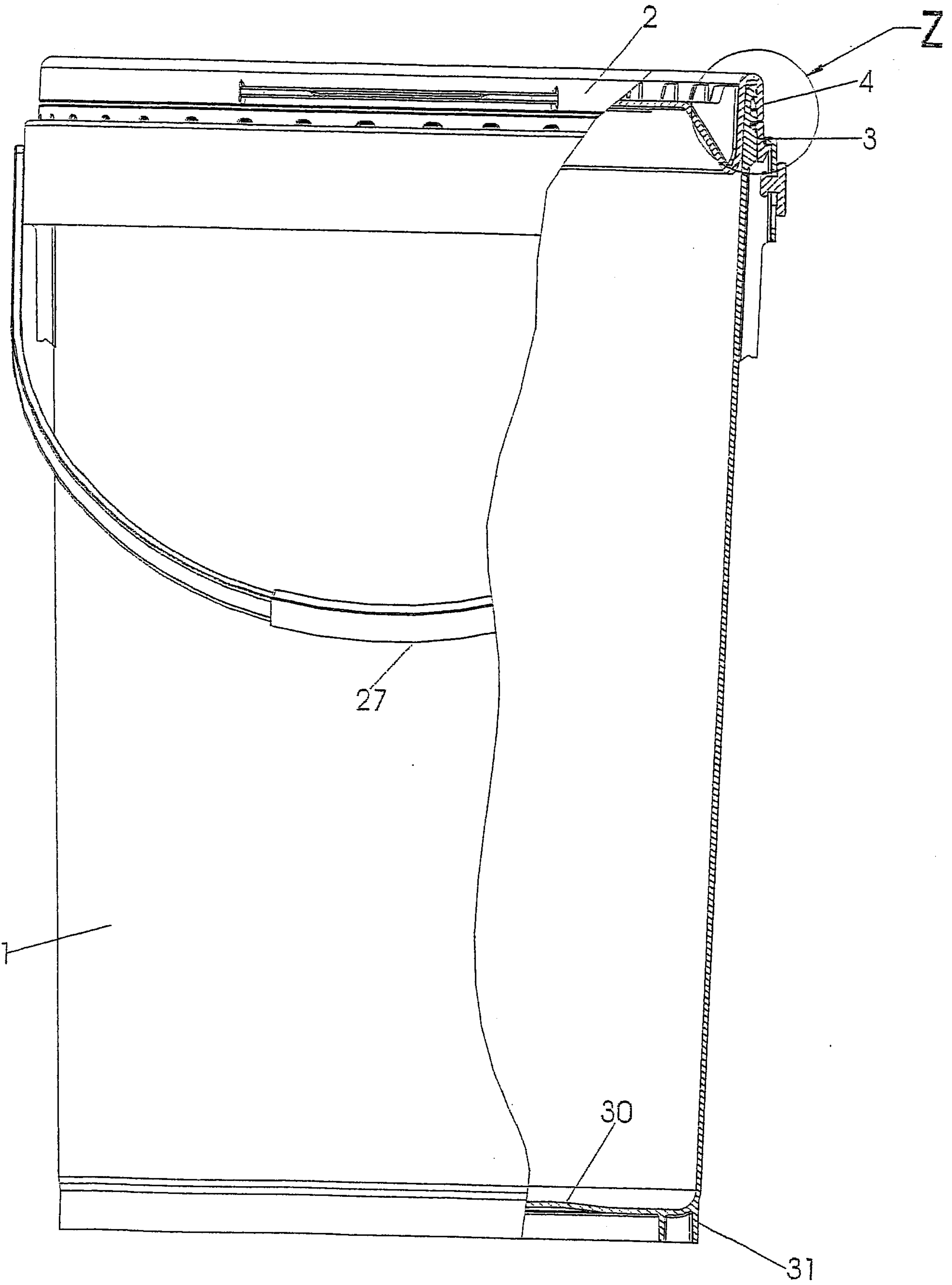



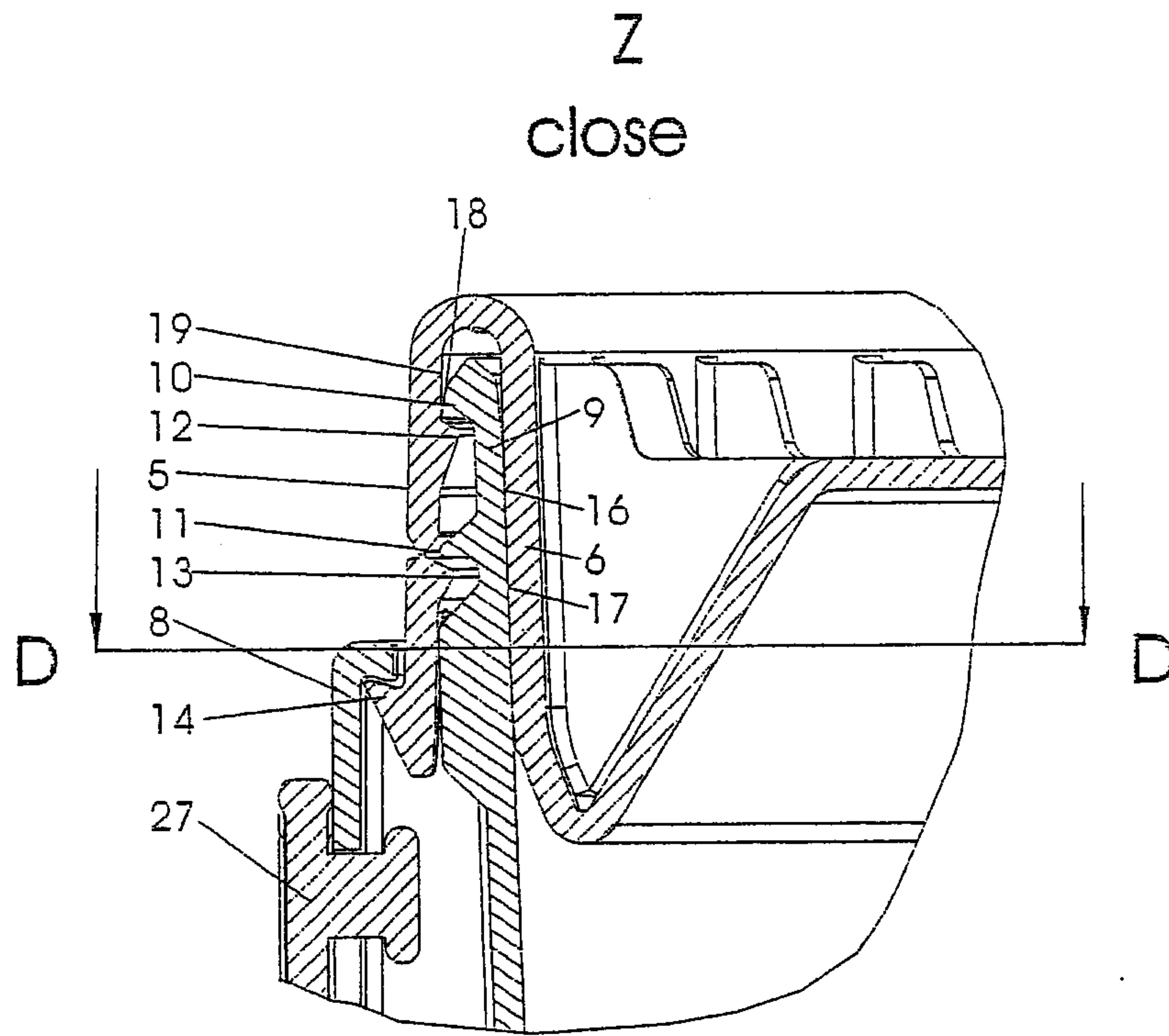

Fig.2c

D-D

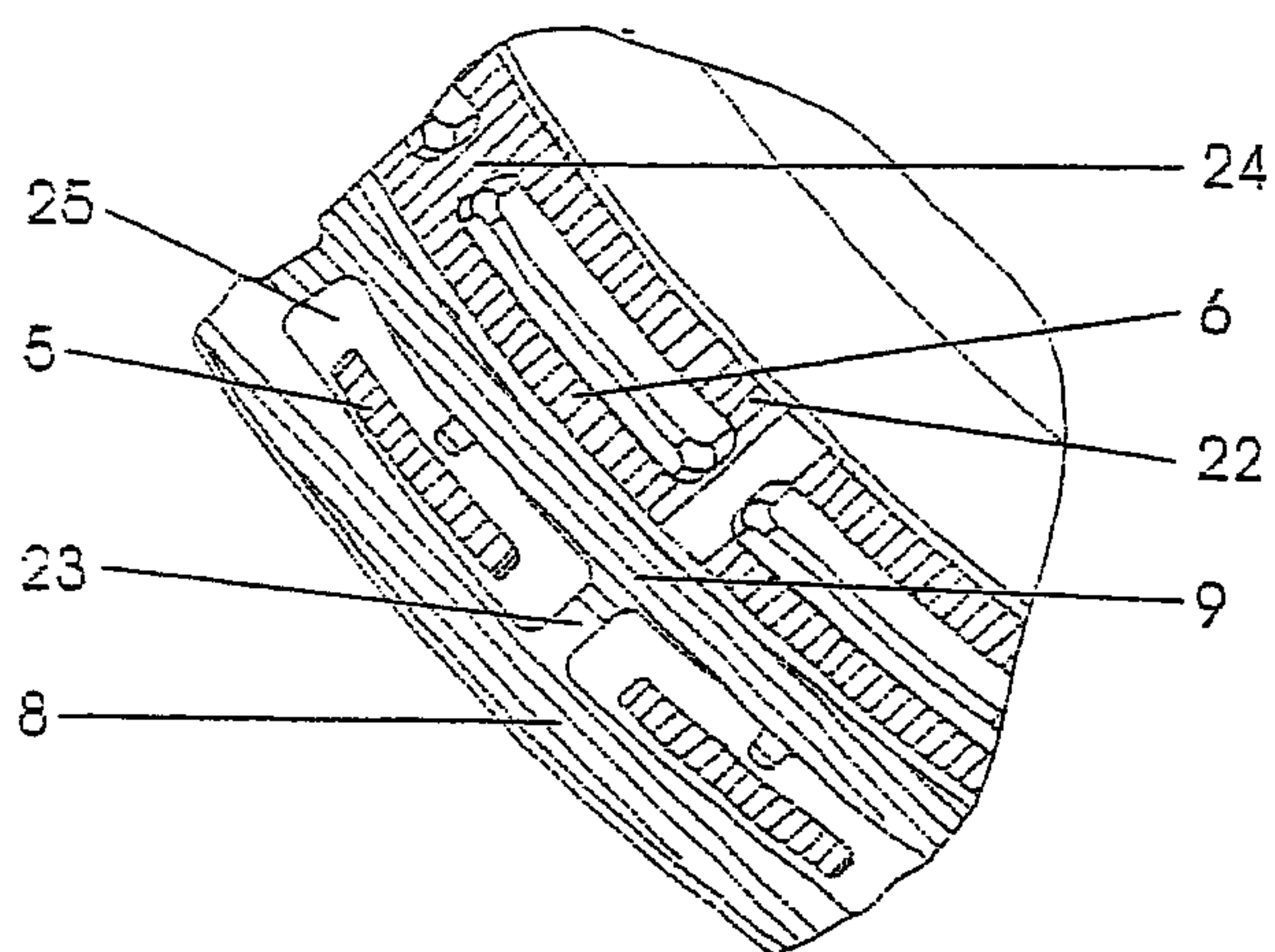

Fig.3

D-D

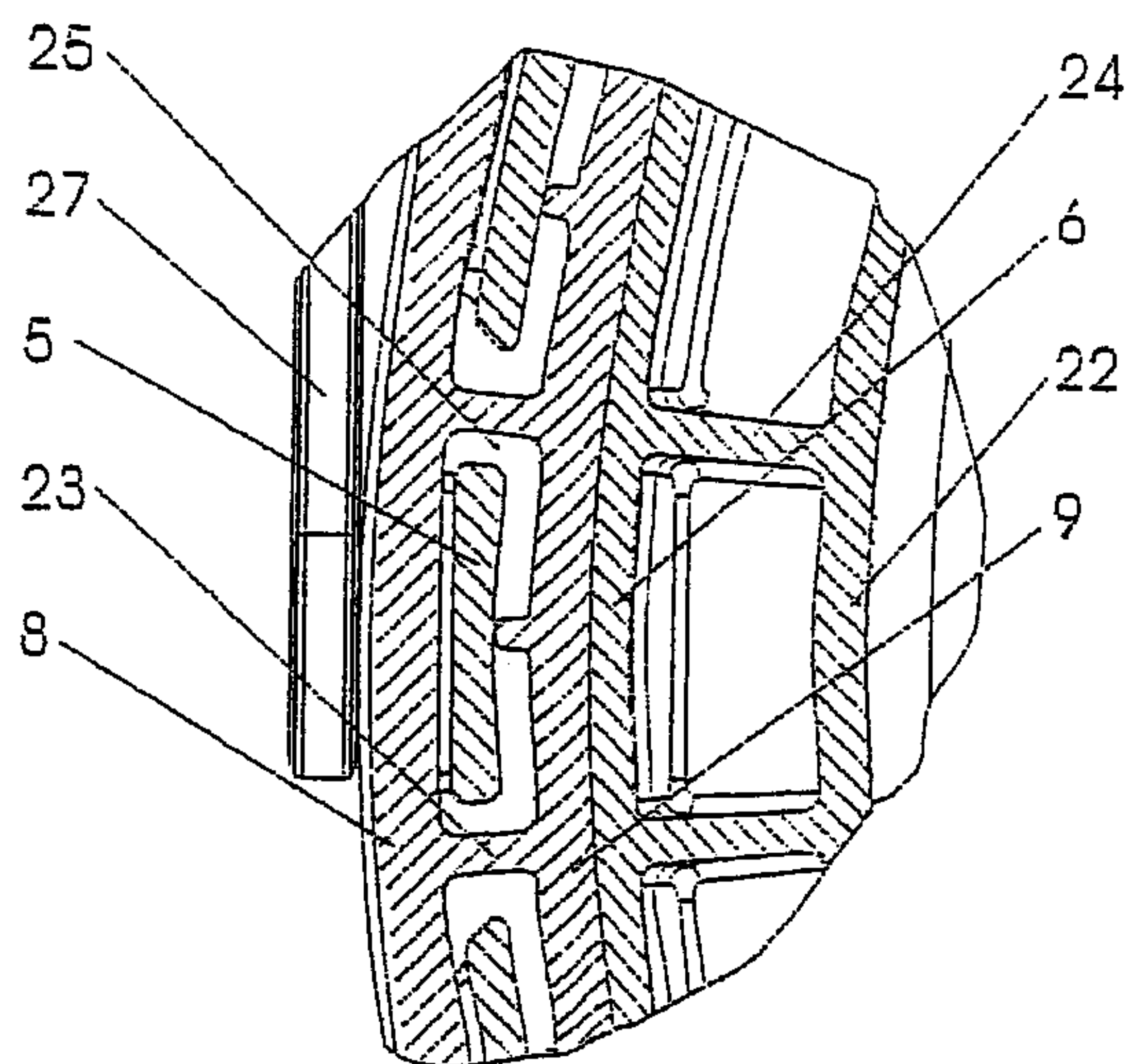

Fig.4

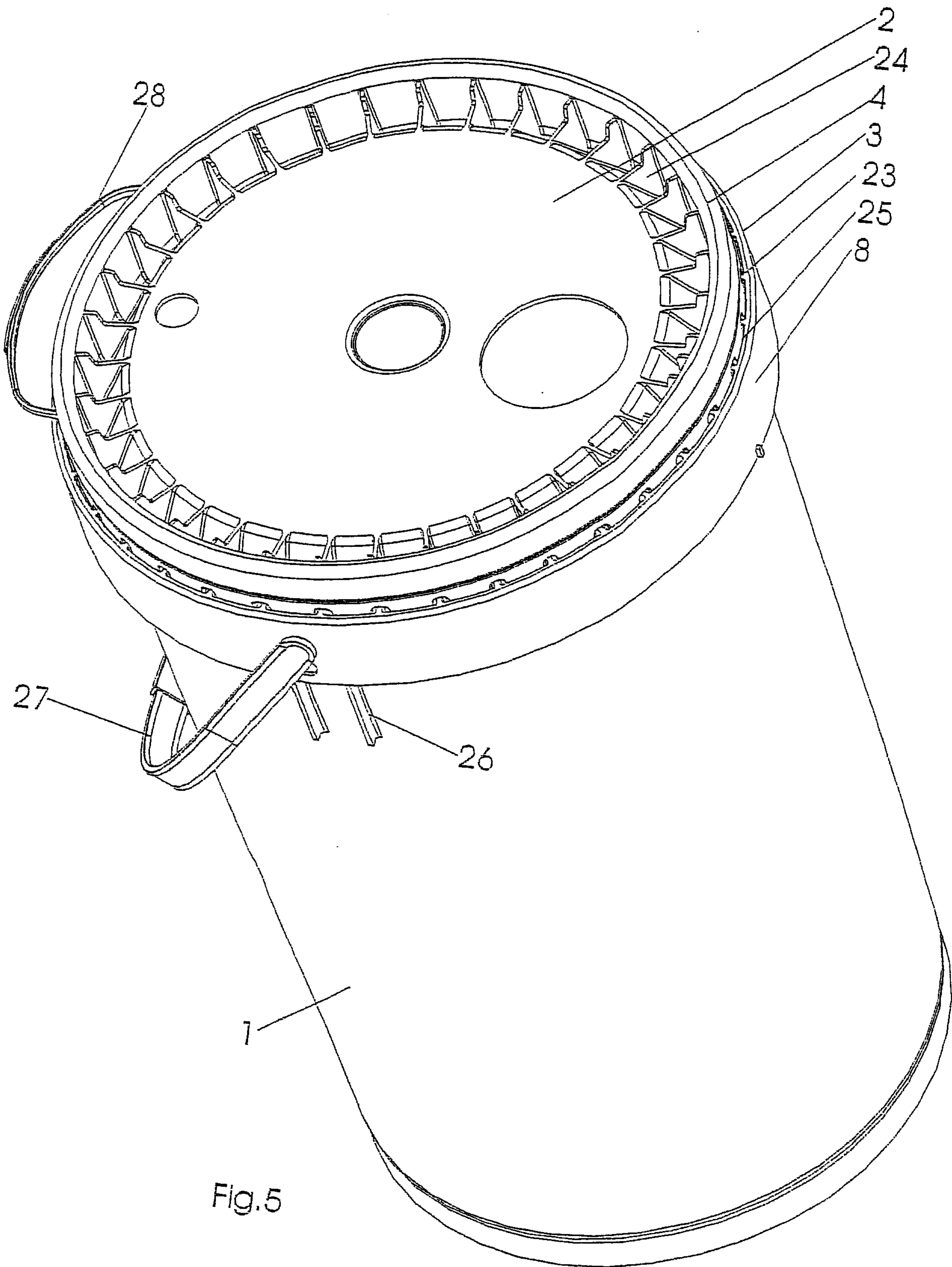

Fig.5

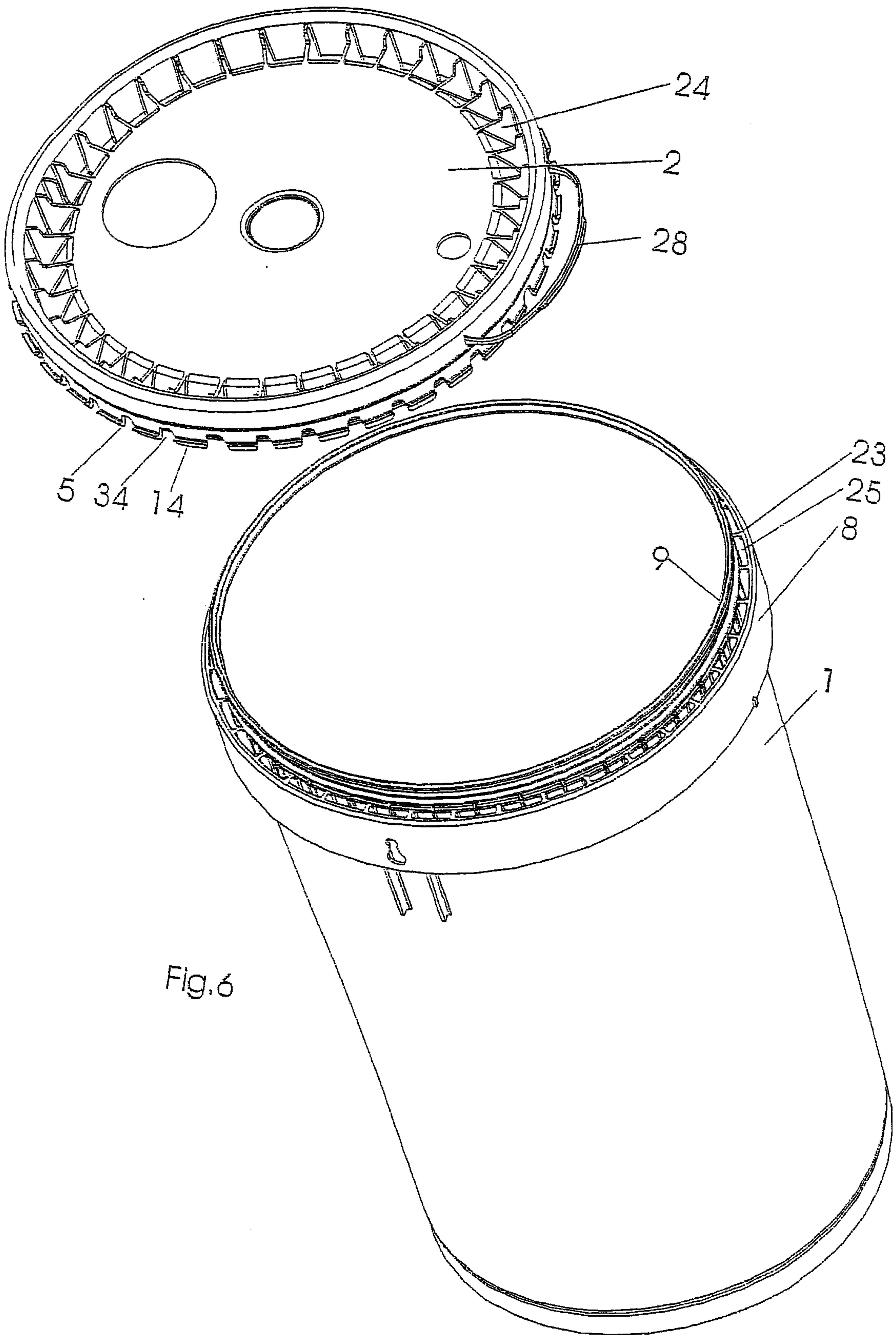

Fig. 6

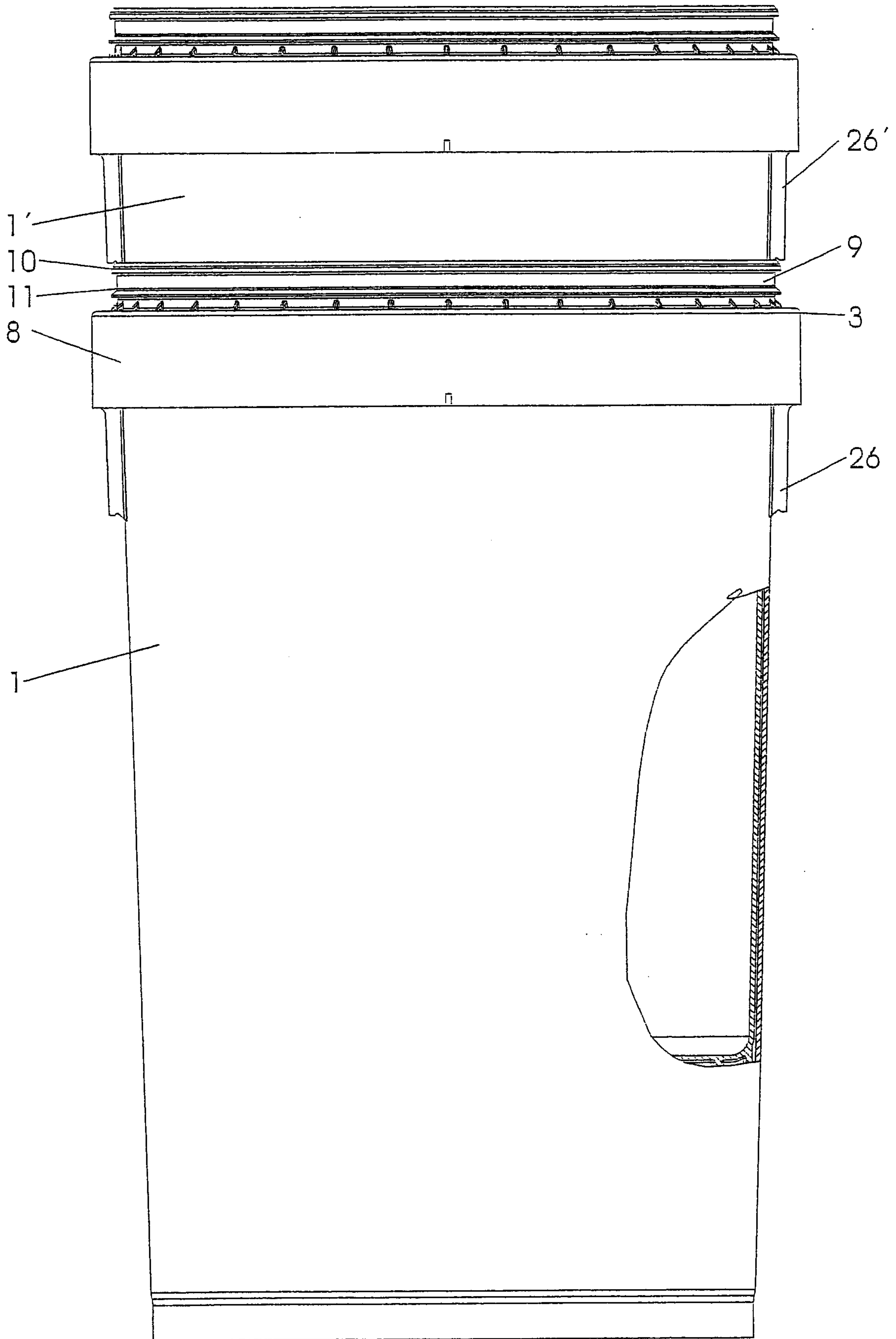

Fig. 7

Fig.8a

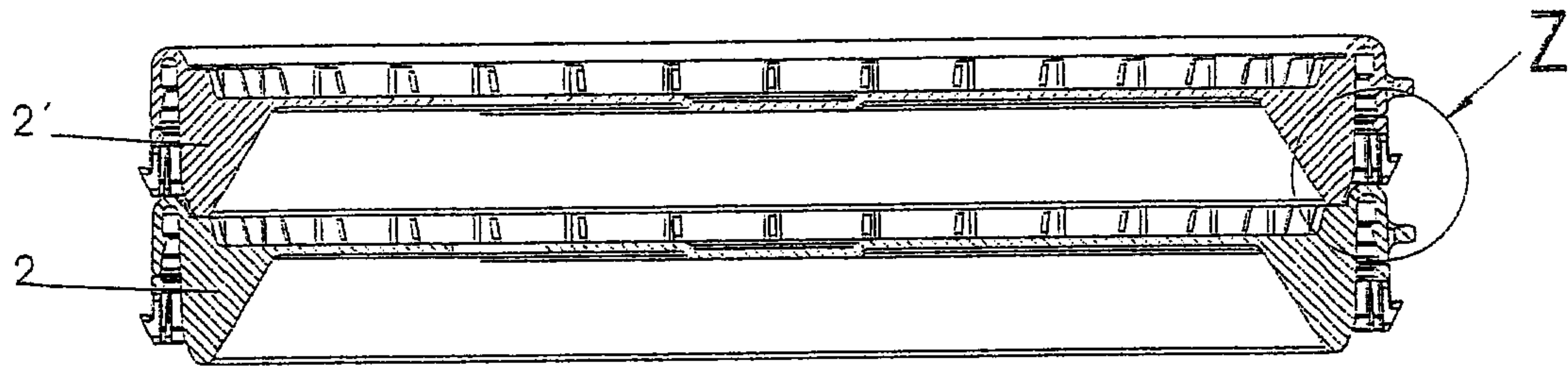
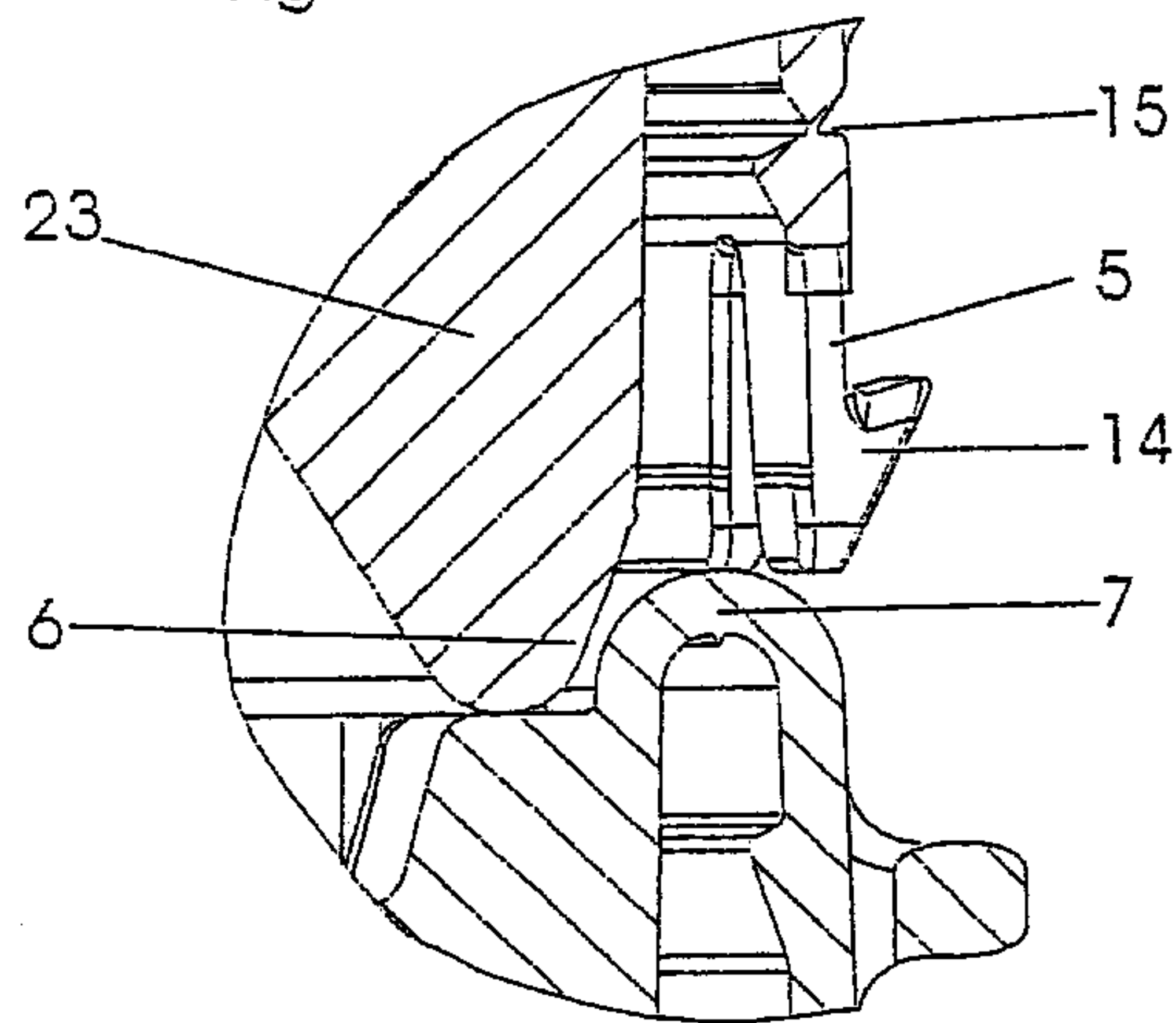

Fig.8b



Z  
2:1

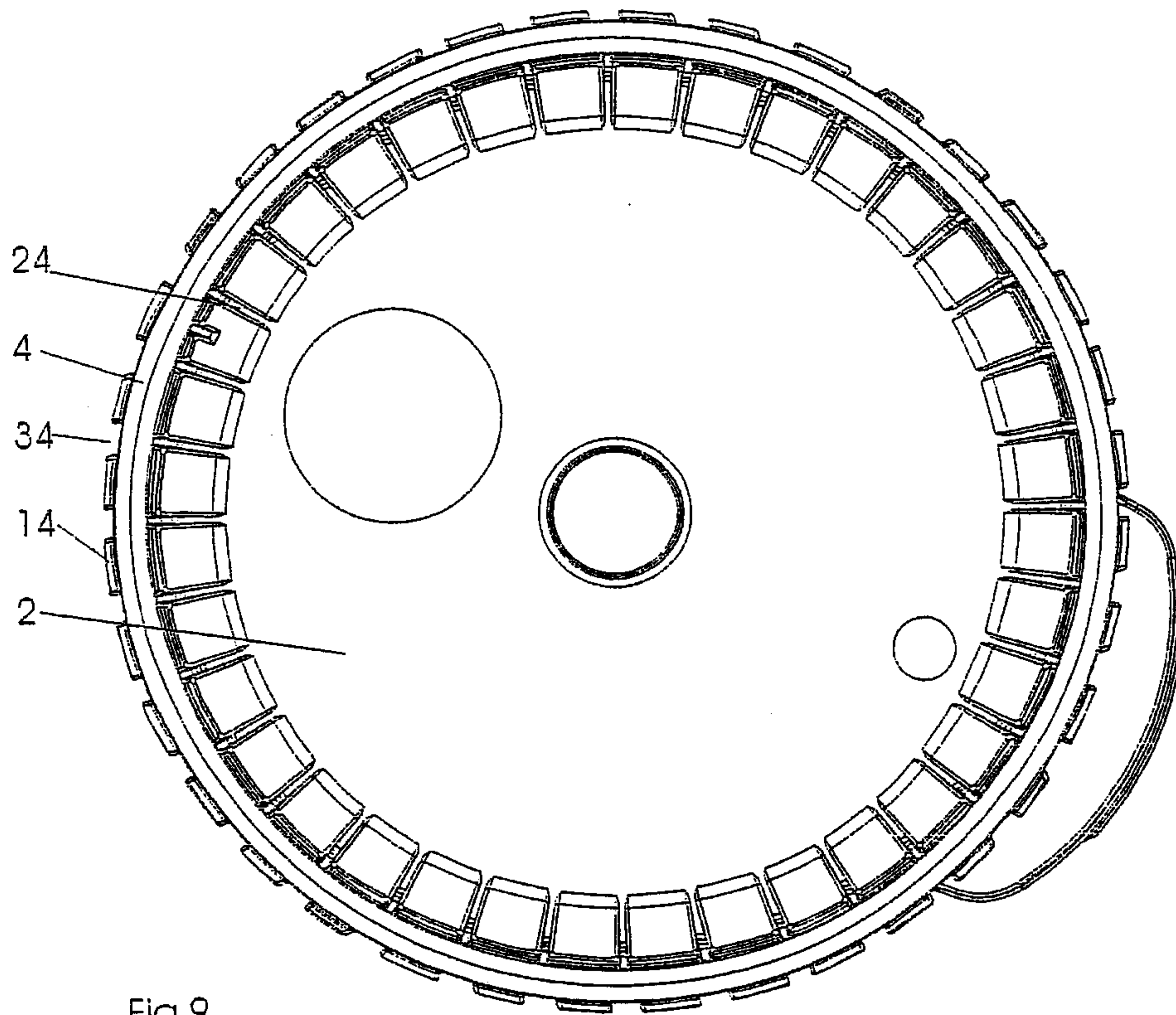

Fig. 9

