

(19) World Intellectual Property Organization  
International Bureau



(43) International Publication Date  
18 December 2003 (18.12.2003)

PCT

(10) International Publication Number  
**WO 03/103402 A1**

(51) International Patent Classification<sup>7</sup>: **A21C 9/06**

**Hiroyuki**; c/o Rheon Automatic Machinery Co., Ltd., 2-3, Nozawa-machi, Utsunomiya-shi, Tochigi 320-0071 (JP).

(21) International Application Number: PCT/JP03/02153

(22) International Filing Date: 26 February 2003 (26.02.2003)

(74) Agents: **YAMASAKI, Yukuzo** et al.; Yamasaki Law and Patent Office, Sogo Nagatacho Bldg. 8F, 11-28, Nagatacho 1-chome, Chiyoda-ku, Tokyo 100-0014 (JP).

(25) Filing Language: English

(26) Publication Language: English

(81) Designated States (national): AT, AU, CA, CH, CN, DE, ES, GB, KR, NZ, PH, RU, SE, SG.

(30) Priority Data:  
2002-167647 7 June 2002 (07.06.2002) JP

(84) Designated States (regional): European patent (AT, BE, BG, CH, CY, CZ, DE, DK, EE, ES, FI, FR, GB, GR, HU, IE, IT, LU, MC, NL, PT, SE, SI, SK, TR).

(71) Applicant: **RHEON AUTOMATIC MACHINERY CO., LTD.** [JP/JP]; 2-3, Nozawa-machi, Utsunomiya-shi, Tochigi 320-0071 (JP).

**Published:**  
— with international search report

(72) Inventors: **OKAIZUMI, Hiroyuki**; c/o Rheon Automatic Machinery Co., Ltd., 2-3, Nozawa-machi, Utsunomiya-shi, Tochigi 320-0071 (JP). **YAMANAKA,**

For two-letter codes and other abbreviations, refer to the "Guidance Notes on Codes and Abbreviations" appearing at the beginning of each regular issue of the PCT Gazette.

(54) Title: METHOD AND APPARATUS FOR PRODUCING A CONTINUOUS FOOD SHAPED AS A BAR AND A BELT CONVEYOR USED FOR ITS PRODUCTION

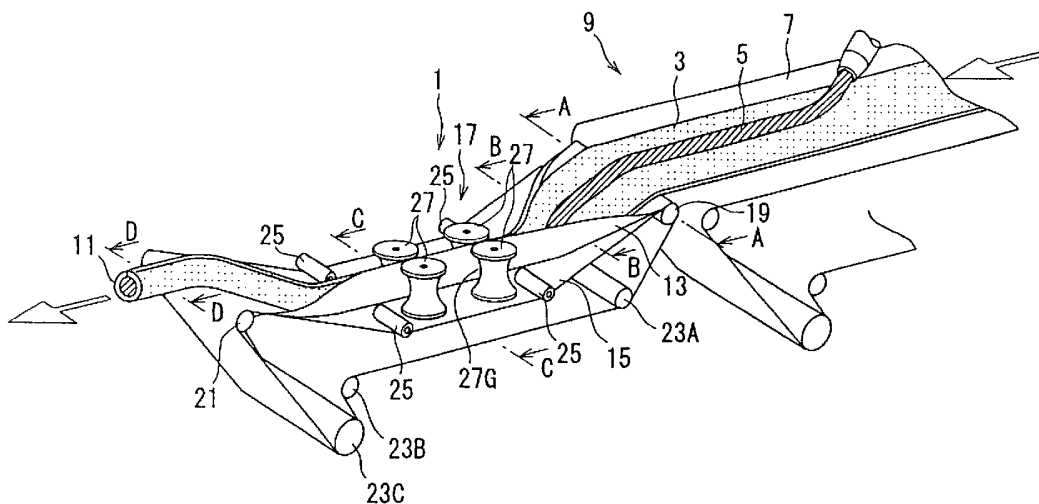

(57) Abstract: A method for producing a food shaped as a continuous bar by placing a continuous inner material (5) on a continuous strip of an outer layer material (3) that is transferred on a former belt (17), comprising the steps of placing food material that includes the inner material (5) placed on the strip of the outer layer material (3) in a channel space defined by the former belt (17) while it is running; and shaping part (13) of the former belt (1.7) that is located at the channel space as a sleeve by pushing and joining edges of the former belt (17) by a pushing device (27,35) to allow edges (3A) of the outer layer material (3) to be joined.



WO 03/103402 A1

## DESCRIPTION

Method and Apparatus for Producing a Continuous Food  
Shaped as a Bar and a Belt Conveyor Used for its Production

Field of the Invention

This invention relates to a method and an apparatus for producing a piece of food shaped as a continuous bar that has an inner material such as jam or other filling and an outer layer material (e.g. dough) that surrounds the inner material. The invention also relates to a belt conveyor used for producing the continuous piece of food.

Description of the Prior Art

Japanese Patent 8-242750 A (prior art 1) and Japanese Patent 10 2896503 B (prior art 2) disclose such a method, apparatus, and belt conveyor.

In prior art 1, a continuous outer layer material is shaped as a strip and placed on an endless belt conveyor that runs horizontally, and a continuous inner material shaped as a bar, which is to be surrounded by the outer layer material, is placed on the strip of the outer layer at its center (center of its width). Both edges of the upper part of the endless, horizontal belt conveyor are then forced to curve upward by rollers so that the outer layer material surrounds the inner material.

20 Since in prior art 1 the horizontal belt conveyor is arranged so that both edges of its upper part are curved upward, the belt conveyor will be rather long in the direction that it runs, and the edges are subjected to great tension, thereby causing a problem in that the life of the belt conveyor is shortened.

25 Prior art 2 discloses a belt conveyor that comprises a V-shaped belt located at the center of the belt conveyor (center of its width), a base belt disposed around the outer periphery of the V-shaped belt so that the base belt and the V-shaped belt form one body, and a plurality of strip belts disposed around the outer periphery of the base belt, which strip belts are arranged along the path in which the belt conveyor runs. In this belt

30

conveyor the strip belts can be easily curved upward to wrap an inner material by an outer layer material that is placed on the belt conveyor. However, the structure of the belt conveyor is complicated. Further, part of the outer layer material or powder  
5 used or both may be caught between the strip belts and they may remain there. This requires troublesome cleaning of the strip belts.

The purpose of the present invention is to resolve this problem and those drawbacks of the prior art discussed above.

#### 10 Summary of the Invention

The method of the present invention for producing a piece of food shaped as a continuous bar by placing a continuous inner material on a continuous outer layer material that is shaped as a strip and transferred includes the steps of placing food material  
15 that includes the inner material placed on the strip of the outer layer material in a channel (or groove) space (or passage) defined by a former belt while it is running, and shaping the former belt into a sleeve such that both edges of the former belt are joined to shape the strip of the outer layer material as a sleeve that  
20 surrounds the inner material.

In one aspect of this invention the edges of the former belt are pressed together by pushing means or a plurality of especially-shaped guiding former members.

#### Brief Description of the Drawings

Fig. 1 is a perspective view showing a first embodiment of  
25 the apparatus of the present invention.

Fig. 2A is a cross-sectional view taken along the cutting line A-A in Fig. 1.

Fig. 2B is a cross-sectional view taken along the cutting line B-B in Fig. 1.

30 Fig. 2C is a cross-sectional view taken along the cutting line C-C in Fig. 1.

Fig. 2D is a cross-sectional view taken along the cutting line D-D in Fig. 1.

Fig. 3 is a perspective view showing a second embodiment

of the apparatus of the present invention.

Fig. 4A is a cross-sectional view corresponding to Fig. 2A of the first embodiment, showing the inner material, the outer layer material, and the conveyor in the second embodiment.

5 Fig. 4B is a cross-sectional view corresponding to Fig. 2B of the first embodiment, showing the inner material, the outer layer material, and the conveyor in the second embodiment.

Fig. 4C is a cross-sectional view corresponding to Fig. 2C of the first embodiment, showing pushing members in the second  
10 embodiment to join the edges of the former belt.

Fig. 4D is a cross-sectional view similar to Fig. 4C, showing the pushing members being moved away from the edges of the former belt.

Fig. 5A is a cross-sectional view showing an alternative  
15 belt conveyer, which can be used in the first and second embodiments.

Fig. 5B is a cross-sectional view of the alternative belt conveyer, showing guiding members for the belt conveyer.

20 Figs. 6A, 6B, and 6C are cross-sectional views showing the steps of the operation of alternative pushing members.

Figs. 7A, 7B, and 7C are cross-sectional views showing the steps of the operation of alternative pushing members.

#### Description of the Preferred Embodiments

25 Below the embodiments of the present invention are explained in detail by reference to the accompanying drawings.

Fig. 1 and Fig. 2 (Figs. 2A-2D) show the first embodiment of the apparatus 1 of the invention for producing a piece of food shaped as a continuous bar. In Fig. 1 the apparatus 1 is located between a transfer conveyer system 9 (to the right in the drawing) and a cutting machine (not shown) that cuts a produced piece of  
30 food shaped as a continuous bar (to the left in the drawing). The conveyor system 9 includes a transfer conveyor 7 that carries a continuous strip of an outer layer material 3 (e.g., dough), which is supplied by a device (not shown) for supplying a continuous  
35 strip of an outer layer material, and a continuous food material 5 shaped as a bar (e.g., jam or other filling), which is

continuously supplied by a device (not shown) for supplying an inner material. The bar-like food material 5 is used as an inner material to be surrounded by the outer material 3.

As shown in Fig. 1, the apparatus 1 has a conveyor belt 17 comprising endless, two-layer belts, namely, a base belt (inner belt) 15 and a former belt (outer belt) 13, which is disposed on or above the outer surface of the inner belt 15. The conveyor belt 17 is supported and guided by a first guide roller 19 located at the upstream end (i.e., the starting end) of the conveyor belt 17 and a second guide roller 21 located at the downstream end (i.e., the turning end). Further, a plurality of intermediate rollers 23A, 23B, and 23C, which are properly spaced apart from each other, are disposed between the first and second guide rollers 19, 21. These intermediate rollers 23A, 23B, and 23C guide the lower part of the endless conveyor belt 17. By operating a controlling motor (not shown), the food materials (inner material 5 and outer layer material 3) are transferred to the left (in Fig. 1).

The endless conveyor belt 17 is so arranged that the central parts of both the inner and outer belts are fixed to each other by using proper fixing tools or an adhesive. The outer, former belt 13 is made of flexible material, so that it can be deformed into a sleeve when both edges of it are joined in a line parallel to the centerline of the conveyor belt 17.

A plurality of rollers 25 (e.g., 4 rollers, as shown in Fig. 1), for depressing and guiding the upper part of the endless, inner belt 15 at its upper surface, are disposed between and at a lower level of the first and second guide rollers 19, 21. These depressing rollers 25 are rotatably mounted on side frames (not shown) disposed at both sides of the conveyor belt 17. Since the rollers 25 depress the inner belt 15, they lower the central part of the upper part of the endless, outer belt 13 through the central part of the endless, inner belt 15, which part is fixed to the corresponding central part of the outer belt 13, thereby defining a channel (or groove) space in the upper part of the endless outer belt.

In the groove space the inner, base belt 15 is in a tensioned state due to the depressing rollers 25, but the upper surfaces

of both sides of the inner, former belt 13 are free from any depression. Thus they can be easily curved upward without applying a great tension.

Two pairs of vertical, former rollers (rolls) 27, 27 are rotatably supported on brackets that are disposed at both sides of the channel space. The former rollers 27, 27 are located between the two pairs of depressing rollers 25, 25, with one pair (25, 25) located upstream and the other pair downstream of the channel space. Each former roller 27 has a curved outer surface 27G (e.g., a semicircular cross section) so that the outer belt 13 will be deformed in the shape of a sleeve when it passes between the former rollers 27 and 27, which are arranged at the sides of the channel space. The deformed outer belt 13 allows the outer layer material 3 to be wrapped around the inner material 5.

The brackets (not shown), which carry the former rollers 27, may be vibrantly moved in the right and left directions by actuators such as pneumatic actuators (not shown) such that the former rollers 27, 27, located at the sides of the channel space, closely approach each other (thereby securing the edges of the outer belt 13 to each other) and move away from each other. By those vibrations, repeated forces are applied to the outer belt 13 and hence to the outer layer material 3, so that the outer layer material 3 securely wraps the inner material 5, and so that the edge surfaces 3A (Fig. 2C) of the outer layer are joined.

Some steps of the operation of the apparatus explained above are shown in Figs. 2A-2D.

Fig. 2A shows the bar-like inner material 5 and the strip of the outer layer material 3 carried on the endless belt conveyor 17 at the position shown by cutting line A-A. As the inner material 5 and the outer layer material 3 come to the position shown by cutting line B-B, the inner belt 15 is lowered by the depressing rollers 25, 25, and thus the central part of the outer belt 13 is lowered by the inner belt 15, so that the channel passage is formed in the outer belt 13.

As in Fig. 2C, when the materials 3 and 5 come to the position shown by cutting line C-C, the former rollers 27, 17 are laterally vibrated to be made to come close to or move away from each other

to make the outer belt 13 be in the shape of a sleeve, and to allow the edges of the belt 13 to be joined. Thus, as previously explained, the outer layer material 3 is to be wrapped around the inner material 5, and the edge surfaces 3A of the outer layer material engage with each other. The produced continuous piece of food, which is shaped as a bar (Fig. D), is then moved away by a conveyor such as a conveyor 9B (shown in Fig. 3).

Now, the second embodiment is explained with reference to Fig. 3 and Fig. 4 (Figs. 4A-4D). Also, some alternative examples are explained in Figs. 5, 6, and 7. In these Figures (3-7) the same or similar numbers are used for the same or similar elements.

The apparatus 1 of the second embodiment shown in Figs. 3 and 4 is similar to the apparatus 1 of the first embodiment shown in Figs. 1 and 2 and differs in that it uses former rollers 28 and a pushing device 29 to make the outer layer material 3 be in the shape of a sleeve, instead of using the former rollers 27 that have a curved surface as in the first embodiment. Other elements function the same as those of the first embodiment. Thus no further explanation is made for those elements.

Each former roller 28 has a straight outer surface as shown in Figs. 3 and 4B. Thus, when the endless belt conveyor 17 shown in Fig. 4A comes to the groove passage, the outer, former belt 13 is bent like a "U" by the depressing rollers 25, 25, the inner belt 15, and the former rollers 28, 28, as in Fig. 4B. The edges of the outer belt 13 are then (preferably, repeatedly or vibrantly) pushed and joined together by pushing members 35A, 35B that are (preferably, vibrantly and) slantwise moved to join the edges.

The mechanism of the pushing device 29 that includes the pushing members 35A, 35B is now briefly explained.

The two pairs of pushing members 35A, 35B are symmetrically arranged at both sides of the groove passage and fixedly mounted on C-shaped frames 37a, 37B through attaching bars 35A. The C-shaped frames 37A (located at one side of the groove passage) are connected to sliders 41A, and the C-shaped frames 37B, located at the other side, are connected to sliders 41B. The sliders 41A and 41B are symmetrically slanted and are slidable in the notches

39A and 39B, respectively, which notches are formed in plates 31A, 31B. These plates are connected by bars 30 to form a frame 33.

An actuator 47, which is vertically moved, for example, by a servomotor, is disposed between the plates 31A, 31B. The  
5 actuator 47 operates to rotate crank members 49 to vertically move the sliders 41A, 41B through connecting rods 45 and guide members 43. Since the sliders 41A, 41B move slantwise simultaneously in the same direction, C-shaped frames 37A, 37B and the pushing  
10 members 35A, 35B move slantwise and simultaneously in the same direction, as shown by slanted arrows in Figs. 3, 4C, and 4D. The forces applied slantwise to the outer layer material better secure the bonding of the edge surfaces of the outer layer material.

Since the width of inner belt 15 is less than that of the outer, former belt 13, powder, if it is used, would not enter  
15 between the inner and outer belts.

Although in the first and second embodiments the conveyer belt 17 that has two-layer belts is used, a conveyer belt of a single layer may be used. In that case, the degree of the tension of the part of the single-layer conveyer belt between the rollers  
20 19 and 21 is adjusted, and the former rollers 27 in the first embodiment or the former rollers 28 and the pushing device 29 are arranged to be located between the rollers 19 and 21.

Fig. 5 shows an alternative example of the endless belt conveyer 17. As shown in Fig. 5A, the inner, base belt 15, which  
25 is fixed to the outer, forming belt 13, is narrow and in the shape of a trapezoid. As shown in Fig. 5B, the trapeziform base belt 15 may be guided to a lower position by two guide members 25A instead of the depressing rollers 25, which guide members 25A have a shape complementary to the shape of the base belt 15.

30 Fig. 6 shows an alternative example of the pushing members 35A, 35B shown in Figs. 3 and 4. As shown in Fig. 6A, each of the pushing members 35A, 35B has two members, namely, an upper pushing member 35U and a lower pushing member 35L. The lower pushing member 35L is located at the distal end of a plate member  
35 35P, and the upper pushing member 35U is placed on the plate member 35P. The upper pushing member 35U is made of resilient material.

Thus, when the former belt 13 is deformed as a "U" as

explained for the second embodiment, the pushing members 35A, 35B approach the edges of the former belt 13 to form the U-shaped belt 13 as a sleeve. During this operation the upper pushing members 35U, 35U first contact the edges of the former belt 13, and then  
5 the lower pushing members 35L, 35L contact the parts of the belt 13 at the points just below the edges, as shown in Figs. 6A, 6B, and 6C. This structure is advantageous in that the outer layer material will not escape from the closed former belt 13 shaped as a sleeve, since its edges are joined first, and then the lower  
10 parts of them are pushed together.

Fig. 7 shows an alternative example of the upper pushing member 35U shown in Fig. 6. The upper pushing member 35U of this alternative example has two members, namely, a distal, movable member 35M provided with a spring S (e.g., a coil spring) at its  
15 rear and a proximal member (no number is assigned to it) held in the plate member 35P. The distal, movable member 35 M is connected to the proximal member through the spring S. This structure of the pushing member functions the same as do the pushing members 35A, 35B shown in Fig. 6.

20 The embodiments and examples explained above are exemplary only, to explain the present invention. One skilled in the art will understand that other variations and modifications can be made without departing from the spirit of the present invention.

CLAIMS

1. A method for producing a food shaped as a continuous bar by placing a continuous piece of inner material on a continuous strip of an outer layer material that is transferred on a former belt, comprising the steps of placing food material that includes the inner material placed on the strip of the outer layer material in a channel space defined by the former belt while it is running; and shaping part of the former belt that is located at the channel space as a sleeve by pushing and joining edges of the former belt by a pushing device to allow edges of the outer layer material to be joined.
2. The method of claim 1, wherein the channel space has a U-shaped cross section formed by the former belt.
3. The method of claim 1 or 2, wherein the pushing device has upper pushing parts and lower pushing parts, and wherein the edges of the former belt are pressed and joined first by the upper pushing parts, and parts of the former belt that are just below the edges are then pressed by the lower pushing parts.
4. An apparatus for producing a food shaped as a continuous bar comprising:
  - an endless, former belt;
  - upstream and downstream guide rollers for guiding the endless, former belt while it is running;
  - a plurality of depressing members disposed at a level that is lower than the level of the upstream and downstream guide rollers, for depressing and guiding a guide belt fixedly attached to the former belt so as to allow the former belt to be deformed to define a channel space;
  - former means to join edges of part of the endless, former belt that has defined the channel space, thereby shaping the part of the former belt as a sleeve.
5. The apparatus of claim 4, wherein the former means includes

forming and guiding members for shaping the part of the endless, former belt to form a U-shape and pushing means for pushing and joining the edges of the U-shaped part.

6. The apparatus of claim 5, wherein the pushing means includes first pushing parts for pushing and joining the edges of the U-shaped part and second pushing parts for pushing parts of the U-shaped part that are located below the edges.
7. A belt used as an endless, conveyor belt for a device that produces a continuous piece of food shaped as a bar, comprising:
  - an outer, former belt; and
  - an inner, base belt fixed at its central part to a central part of the outer, former belt.
8. The belt of claim 7, wherein the inner, base belt is narrower than the outer, former belt.
9. The apparatus of claim 4, wherein the endless, former belt is a two-layer belt having an outer, endless former belt and an inner, endless guide belt partly fixed to the former belt, and wherein the depressing members depress part of the inner, endless guide belt between the upstream and downstream guide rollers to allow the part of the former belt to define the channel space.
10. The apparatus of claim 9, wherein the inner, endless guide belt is fixed at its central part to the central part of the outer, endless former belt.
11. The apparatus of claim 9, wherein the former means includes a plurality of members for guiding and forming the part of the outer, endless former belt as a sleeve, and wherein the plurality of members move vibrantly to approach close to and move away from each other.
12. A method for producing a food shaped as a continuous bar

by placing a continuous inner material on a continuous strip of an outer layer material that is transferred on a two-layer belt while it is running, the two-layer belt having an outer, former belt and inner belt, comprising the steps of placing food material that includes the inner material placed on the strip of the outer layer material in a channel space defined by the two-layer belt while it is running; and allowing the outer, former belt to pass through a space formed as a sleeve, thereby allowing the inner material to be wrapped by the outer layer material.

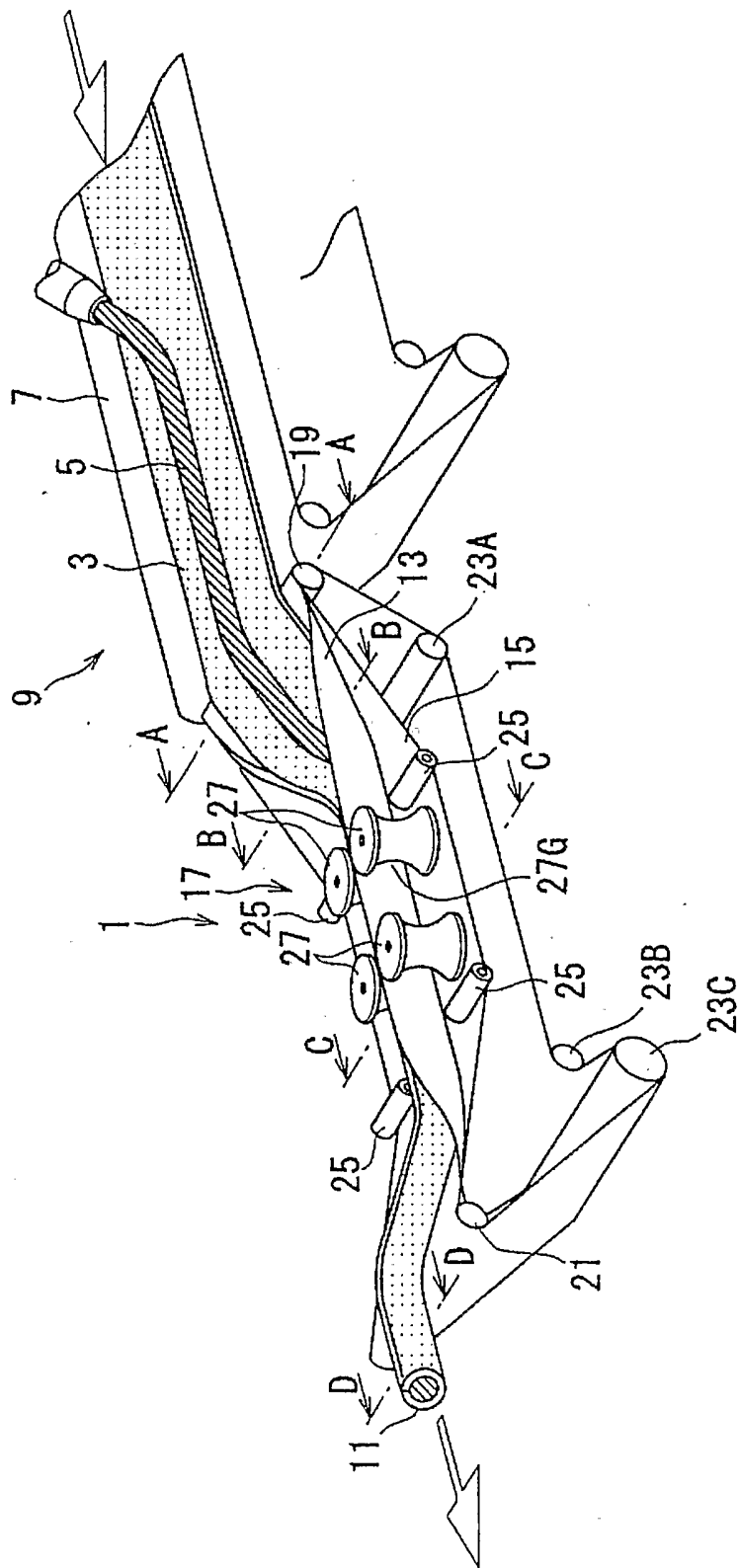

Fig. 1

Fig. 2A

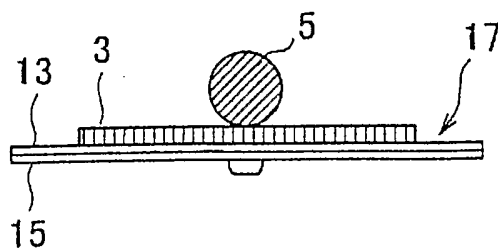

Fig. 2B

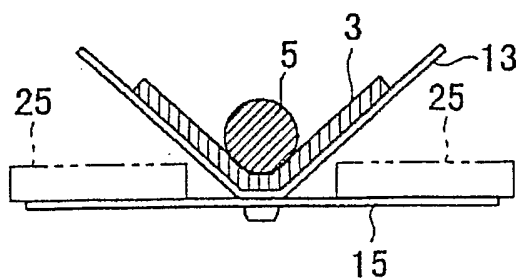

Fig. 2C

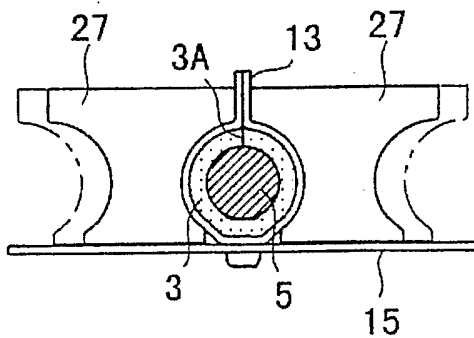

Fig. 2D

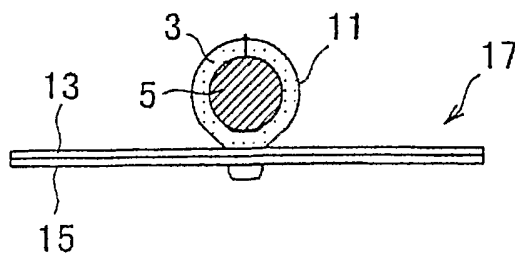

Fig. 3

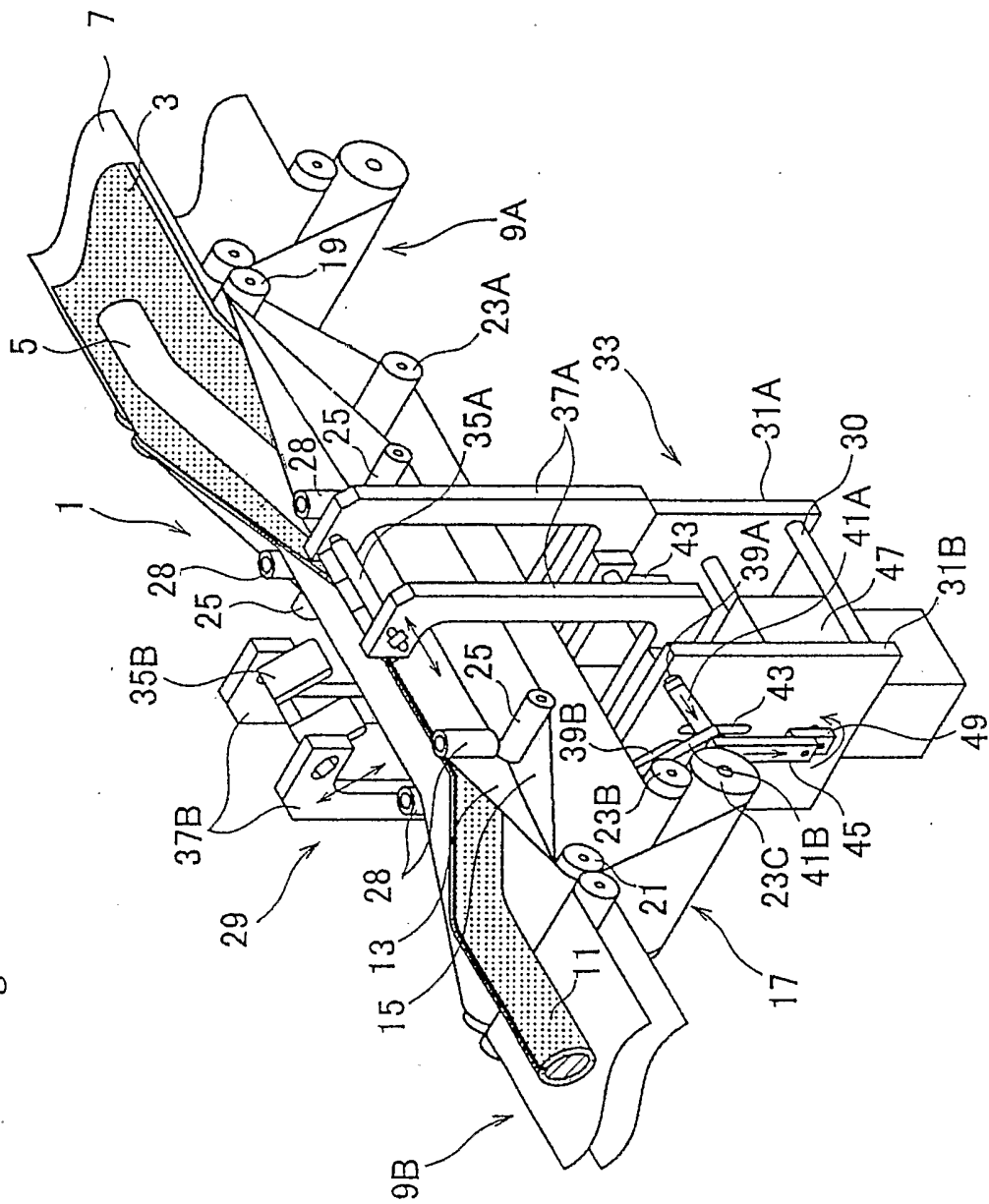

Fig. 4A

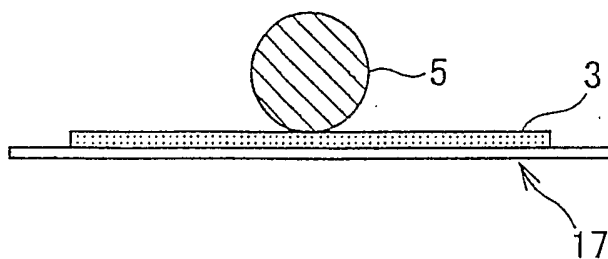

Fig. 4B

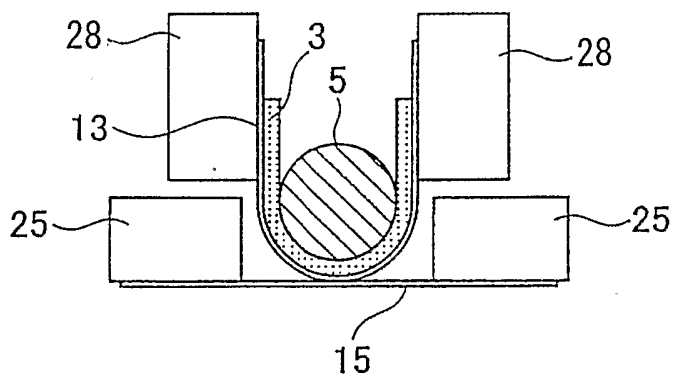

Fig. 4C

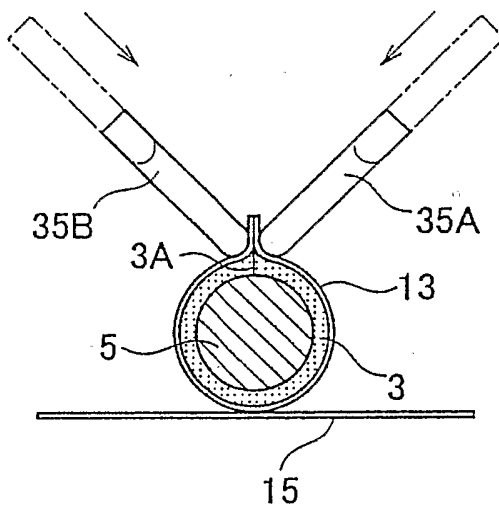

Fig. 4D

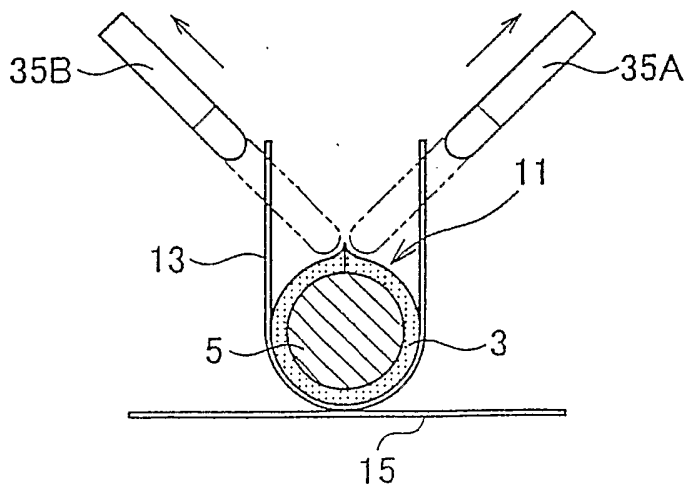

Fig. 5A

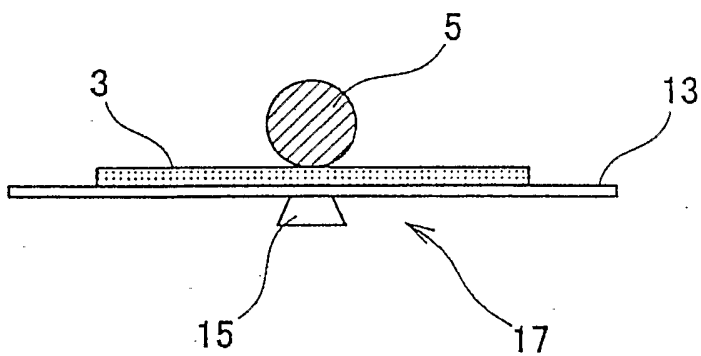

Fig. 5B

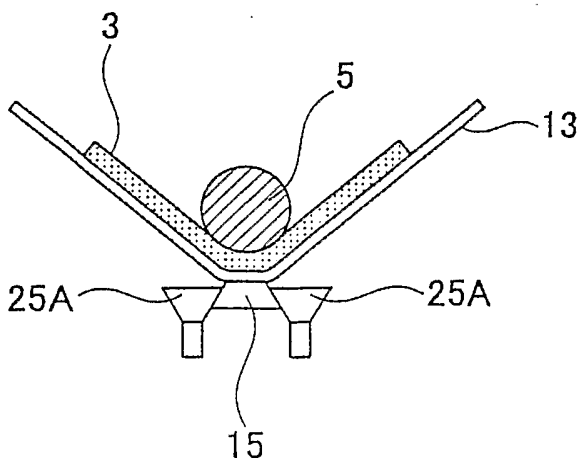

Fig. 6A

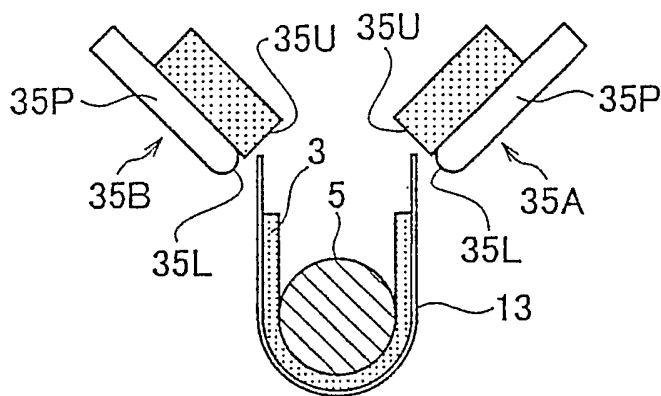

Fig. 6B

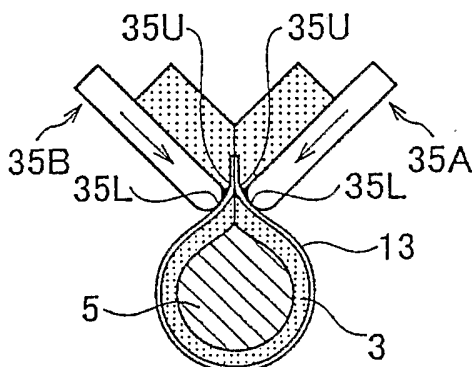

Fig. 6C

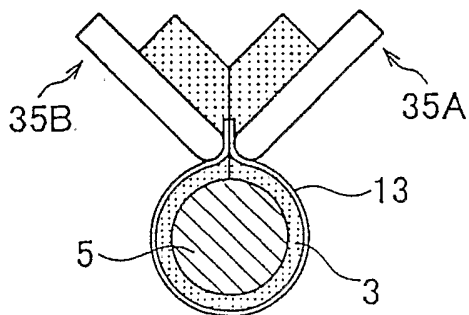

Fig. 7A

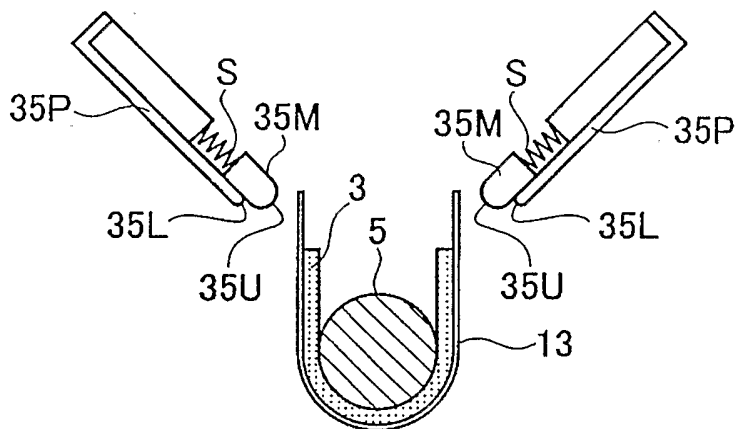

Fig. 7B

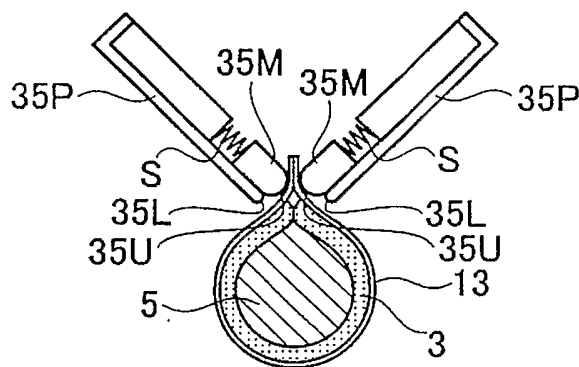
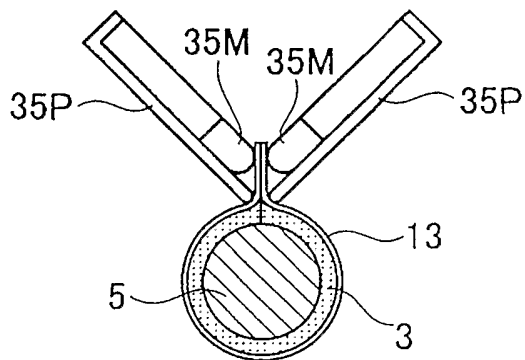

Fig. 7C



## INTERNATIONAL SEARCH REPORT

International Application No

PCT/JP 03/02153

A. CLASSIFICATION OF SUBJECT MATTER  
IPC 7 A21C9/06

According to International Patent Classification (IPC) or to both national classification and IPC

## B. FIELDS SEARCHED

Minimum documentation searched (classification system followed by classification symbols)  
IPC 7 A21C

Documentation searched other than minimum documentation to the extent that such documents are included in the fields searched

Electronic data base consulted during the international search (name of data base and, where practical, search terms used)

EPO-Internal

## C. DOCUMENTS CONSIDERED TO BE RELEVANT

Category °	Citation of document, with indication, where appropriate, of the relevant passages	Relevant to claim No.
X	WO 98 25480 A (KOBIRD CO LTD ;KOBAYASHI MASAO (JP)) 18 June 1998 (1998-06-18) cited in the application	1,2,7,8, 12
A	the whole document	4-6,9-11
X	NL 9 202 191 A (BALLEGOOIE B V VAN) 18 July 1994 (1994-07-18)	1,2
A	figures	7,8
X	US 2 960 045 A (KURT PENTZLIN) 15 November 1960 (1960-11-15) the whole document	1,2
X	FR 2 649 591 A (BALPE MICHEL) 18 January 1991 (1991-01-18) the whole document	1,2
	-/--	

 Further documents are listed in the continuation of box C. Patent family members are listed in annex.

° Special categories of cited documents :

- \*A\* document defining the general state of the art which is not considered to be of particular relevance
- \*E\* earlier document but published on or after the international filing date
- \*L\* document which may throw doubts on priority claim(s) or which is cited to establish the publication date of another citation or other special reason (as specified)
- \*O\* document referring to an oral disclosure, use, exhibition or other means
- \*P\* document published prior to the international filing date but later than the priority date claimed

- \*T\* later document published after the international filing date or priority date and not in conflict with the application but cited to understand the principle or theory underlying the invention
- \*X\* document of particular relevance; the claimed invention cannot be considered novel or cannot be considered to involve an inventive step when the document is taken alone
- \*Y\* document of particular relevance; the claimed invention cannot be considered to involve an inventive step when the document is combined with one or more other such documents, such combination being obvious to a person skilled in the art.
- \* & \* document member of the same patent family

Date of the actual completion of the international search

5 June 2003

Date of mailing of the international search report

17/06/2003

Name and mailing address of the ISA

European Patent Office, P.B. 5818 Patentlaan 2  
NL - 2280 HV Rijswijk  
Tel. (+31-70) 340-2040, Tx. 31 651 epo nl,  
Fax: (+31-70) 340-3016

Authorized officer

Silvis, H

## INTERNATIONAL SEARCH REPORT

International Application No

PCT/JP 03/02153

C.(Continuation) DOCUMENTS CONSIDERED TO BE RELEVANT		
Category °	Citation of document, with indication, where appropriate, of the relevant passages	Relevant to claim No.
X	DE 89 06 356 U (BARTHELS & LÜDERS GMBH) 19 October 1989 (1989-10-19) the whole document ----	1
A	AU 566 508 B (MILONAS J) 22 October 1987 (1987-10-22) -----	

INTERNATIONAL SEARCH REPORT

Information on patent family members

International Application No

PCT/JP 03/02153

Patent document cited in search report		Publication date	Patent family member(s)	Publication date
WO 9825480	A	18-06-1998	JP 2896503 B2	31-05-1999
			JP 10165081 A	23-06-1998
			CN 1204945 A , B	13-01-1999
			DE 69704058 D1	15-03-2001
			DE 69704058 T2	21-06-2001
			EP 0896514 A1	17-02-1999
			WO 9825480 A1	18-06-1998
			US 6001403 A	14-12-1999
-----				
NL 9202191	A	18-07-1994	NONE	
-----				
US 2960045	A	15-11-1960	NONE	
-----				
FR 2649591	A	18-01-1991	FR 2649591 A1	18-01-1991
-----				
DE 8906356	U	19-10-1989	DE 8906356 U1	19-10-1989
-----				
AU 566508	B	22-10-1987	AU 566508 B2	22-10-1987
-----				