



US 20040182737A1

(19) **United States**

(12) **Patent Application Publication**
Sabathiel

(10) **Pub. No.: US 2004/0182737 A1**

(43) **Pub. Date: Sep. 23, 2004**

(54) **TRANSPORT PACKAGING FOR BOTTLES**

Publication Classification

(76) Inventor: **Gundolf Sabathiel, Unterach (AT)**

(51) **Int. Cl.⁷ B65D 79/00**

(52) **U.S. Cl. 206/527**

Correspondence Address:

Law Offices of Karl Hormann

PO Box 381516

Cambridge, MA 02238-1516 (US)

(57) **ABSTRACT**

(21) Appl. No.: **10/433,812**

(22) PCT Filed: **Oct. 4, 2001**

(86) PCT No.: **PCT/AT01/00313**

(30) **Foreign Application Priority Data**

Dec. 6, 2000 (AT)..... GM 899/2000

Transport package [(1)] for bottles [(2)] with toxic contents, cyto-toxic contents or the like, with a container [(5)] for receiving the bottle [(2)] and a closure cap [(6)] for tightly closing the container [(5)], the container being provided with spacer ribs [(10)] distributed over the interior circumference for retaining and clampingly seating a received bottle at a spacing from the interior circumference of the container [(5)].

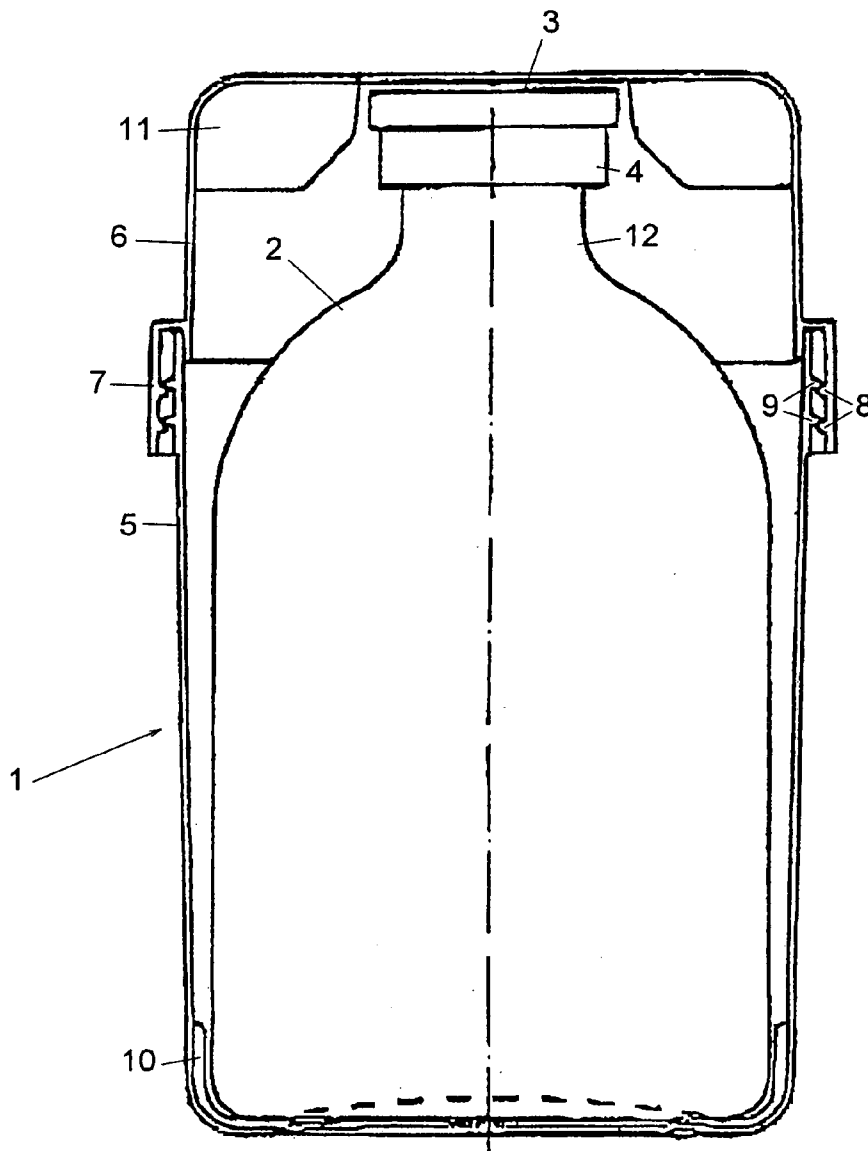

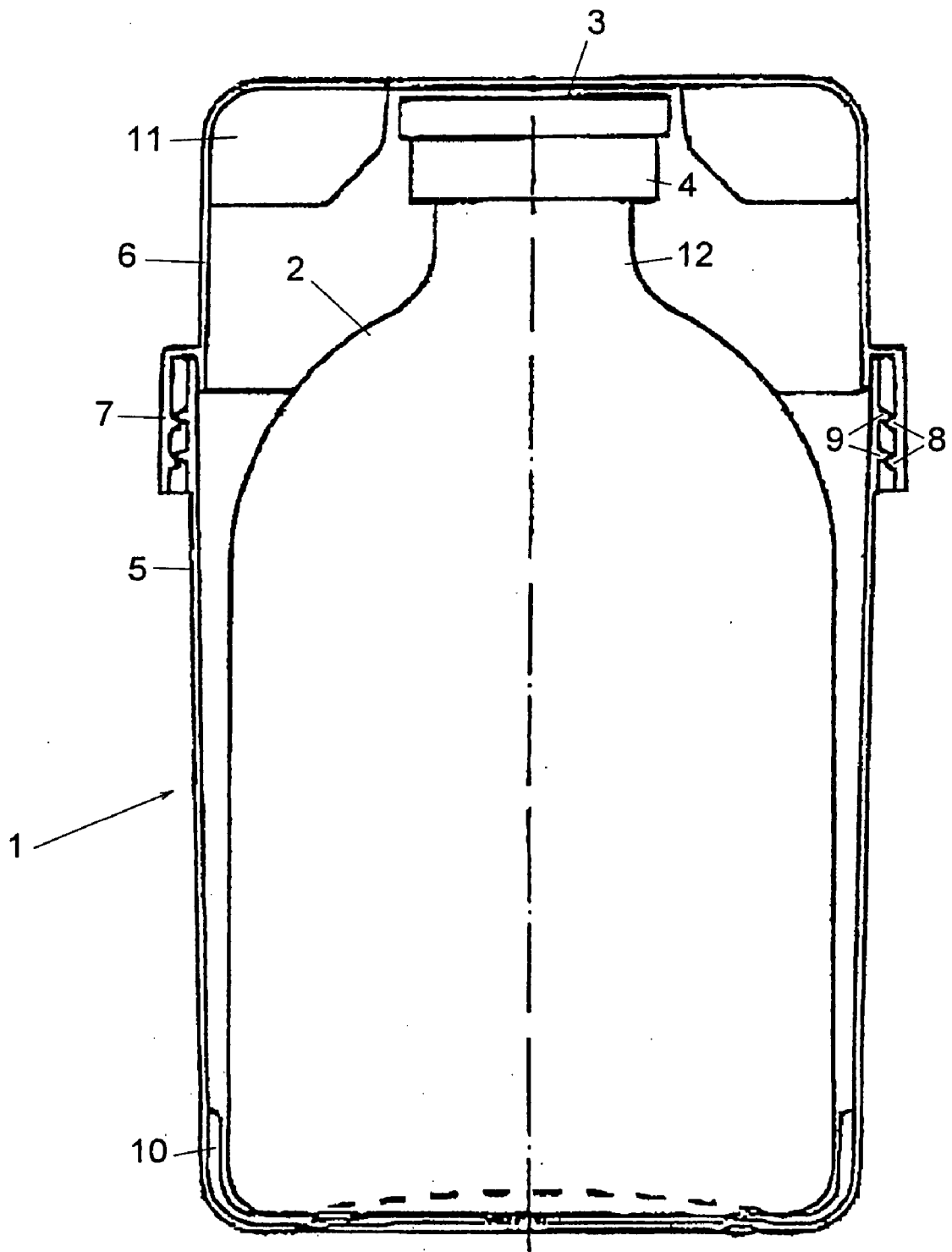

TRANSPORT PACKAGING FOR BOTTLES

BACKGROUND OF THE INVENTION

[0001] 1. Field of the Invention

[0002] The present invention relates to a transport package for bottles of toxic contents, cyto-toxic contents and the like, with a container for receiving the bottle and a closure cap for tightly closing the container, the container being provided with spacer ribs distributed over its internal circumference for clampingly spacing a received bottle from the internal circumference of the container.

[0003] 2. The Prior Art.

[0004] Bottles containing a toxic substance, for instance cyto-toxic substances etc., during transportation constitute a considerable risk for unprotected handling personnel. When filling the bottle it frequently happens that the exterior of the bottle is covered by the contents. This, during handling, involves the hazard of contamination. Moreover, there is a danger of the bottle breaking during its transport and of consequential leakage of the hazardous liquid.

[0005] A transport package of the kind referred to supra is known from Swiss patent 490,240. The known transport package does not provide for securing a bottle in the area of the closure cap. Thus, the neck of the bottle may move and rub at the closure cap with consequential contamination hazard when the transport package is being opened.

[0006] Hence, there is a need for a transport package for such bottles which substantially eliminates the danger of contamination during handling and transport.

OBJECT OF THE INVENTION

[0007] It is an object of the invention to provide such a transport package.

SUMMARY OF THE INVENTION

[0008] The object is accomplished by a transport package which in accordance with the invention is characterized by the closure cap being provided with spacer ribs distributed over the interior circumference for securing the neck of the bottle.

[0009] In this manner, there is provided an exterior package for a bottle which as a result of the spacer construction substantially eliminates any leakage to the exterior of surface contaminants from the bottle over the entire area thereof. Moreover, the support during transport of the bottle is improved so that its closure is well protected.

[0010] It is particularly advantageous in any case if in accordance with a further embodiment of the invention the height of the container is less than the height of the bottle to be received. In this manner, the neck of the bottle, after opening its transport package is readily accessible, so that the bottle may remain in its container and need not be grasped by any hand. This offers protection from contact with any contaminants at the exterior surface of the bottle.

[0011] It is of special advantage to fabricate the transport package from a transparent or translucent plastic material. In this manner the integrity of the bottle and its filling level may be monitored from the exterior.

[0012] [The invention will hereafter be described in greater detail with reference to an embodiment depicted in the drawing. The drawing is a schematic axial sectional view of the transport package in accordance with the invention with a bottle inserted therein.]

DESCRIPTION OF THE DRAWING

[0013] The novel features which are considered to be characteristic of the invention are set forth with particularity in the appended claims. The invention itself, however, in respect of its structure, construction and lay-out, as well as manufacturing techniques, together with other objects and advantages thereof, will be best understood from the following description when read in connection with the drawing, which is a schematic view in axial section of the transport package in accordance with the invention with a bottle inserted therein.

DETAILED DESCRIPTION OF THE PREFERRED EMBODIMENT

[0014] The FIGURE shows a transport package **1** for receiving a bottle **2**. The bottle **2** is, for instance, a hypodermic needle accessible ampule for a cyto-staticum and is closed by a rubber plug **3** which is retained by an aluminum cap **4** and which may be penetrated by an injection needle for removing the contents of the bottle **2**.

[0015] The transport package **1** consists of a substantially cylindrical or pot-shaped container **5** and of a closure cap **6**, which at **7** may be tightly seated on the container **5** as, for instance, by screwing, adhesion etc. In the example shown, the closure cap **6** extends over the upper margin of the container **5** and is screwed thereon by threads **8** and **9**. As an alternative, snap protrusions on the closure cap may snap onto matching snap protrusions at the exterior circumference of the container **5**.

[0016] Near its bottom the container **5** is provided with spacer ribs **10** distributed over its interior circumference which center and clampingly seat the bottle **2** at a distance from the interior circumference of the container **5**. For instance, eight spacer ribs **10** may be provided and symmetrically distributed around the interior circumference, and each spacer rib **10** extends parallel to the axis of the container **5**. However, any other number and arrangements of spacer ribs **10** are possible as well.

[0017] The closure cap **6** is similarly provided with spacer ribs **11** distributed over its interior circumference for centering and holding the neck **12** (or the cap **4** and the plug **3**). For instance, three spacer ribs **11** may be provided which are symmetrically distributed around the interior circumference and extend parallel to the axis of the closure cap **6**. Other numbers and configurations are also possible.

[0018] Instead of its shown round cross-section, the transport package **1** may be of any other cross-section, e.g., square, rectangular or polygonal. The bottle may also be received eccentrically within the transport package **1**.

[0019] Preferably, the entire transport package **1** is made of plastic, such as, for instance, polypropylene. Preferably, the plastic material is transparent or at least translucent to permit control of the integrity or filling level of the bottle **2**. The transport package is suitable for any type of bottles for hazardous materials, i.e. not only for bottles with toxic or

cyto-toxic contents, but also for highly combustible or environmentally dangerous contents.

What is claimed is:

1. Transport package for bottles with toxic, cyto-toxic contents or the like with a container (5) for receiving the bottle (2) and a closure cap (6) for tightly closing the container (5), the container (5) being provided with spacer ribs (10) distributed over its interior circumference for supporting and clampingly seat a received bottle at a spacing from the interior circumference of the container (5), characterized by the fact that the closure cap (6) is provided with spacer ribs (11) distributed over its interior circumference for supporting the neck (12) of the bottle.

2. Transport package according to claim 1, characterized by the height of the container (5) being less than the height of the bottle (2) to be received.

3. Transport package according to one of claims 1 or 2, characterized by the fact that it is made of a transparent or translucent plastic material.

4. A transport container for use with a bottle having a neck and a corpus for receiving a toxic or cyto-toxic substance, the container comprising:

a body having an internal wall therein for forming a first cavity;

a plurality of protrusions extending from the internal wall into the first cavity to form a space within the first cavity for supporting and clampingly engaging the corpus of the bottle at a distance from the internal wall;

a closure cap moveable relative to the body between open and closed positions and having an internal wall for forming a second cavity;

a plurality of protrusions extending from the internal wall of the second cavity for supporting and clampingly engaging the neck of the bottle.

5. The transport container of claim 1, wherein the height of the container is less than the height of the bottle.

6. The transport container of claim 1, wherein the closure cap and the body are provided with mating threads for securing the closure cap on the body.

7. The transport container of claim 1, wherein the container is made of a transparent material.

8. The transport container of claim 1, wherein the container is made of a translucent material.

* * * * *