



(86) Date de dépôt PCT/PCT Filing Date: 2013/12/20
 (87) Date publication PCT/PCT Publication Date: 2014/06/26
 (45) Date de délivrance/Issue Date: 2021/08/10
 (85) Entrée phase nationale/National Entry: 2015/06/02
 (86) N° demande PCT/PCT Application No.: SE 2013/051604
 (87) N° publication PCT/PCT Publication No.: 2014/098762
 (30) Priorités/Priorities: 2012/12/21 (US13/725,000);
 2012/12/21 (SE1251483-2)

(51) Cl.Int./Int.Cl. *C09D 7/80* (2018.01),
B05D 3/06 (2006.01), *B44C 5/04* (2006.01),
C09D 4/02 (2006.01), *C09D 5/16* (2006.01),
C09D 7/61 (2018.01), *E04F 13/18* (2006.01),
E04F 15/02 (2006.01)
 (72) Inventeurs/Inventors:
 JENSEN, HENRIK, DK;
 REENBERG, THEIS, DK;
 ZIEGLER, GORAN, SE
 (73) Propriétaire/Owner:
 VALINGE PHOTOCATALYTIC AB, SE
 (74) Agent: SMART & BIGGAR IP AGENCY CO.

(54) Titre : PROCÉDE DE REVETEMENT D'UN PANNEAU DE CONSTRUCTION ET UN PANNEAU DE CONSTRUCTION

(54) Title: A METHOD FOR COATING A BUILDING PANEL AND A BUILDING PANEL

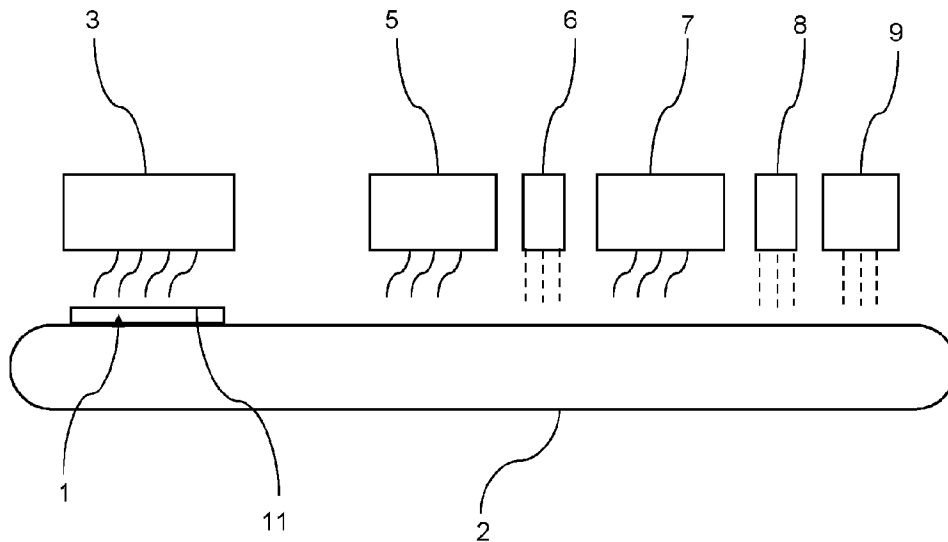

(57) Abrégé/Abstract:

The present disclosure relates to a method for coating a building panel (1, 1'), comprising applying a first coating fluid comprising an organic binder on a surface (11) of the building panel (1,1') to obtain at least one coating layer (13), and applying barrier components and photocatalytic particles, preferably TiO₂, on said at least one coating layer (13). The invention also relates to such a building panel (1, 1').

(12) INTERNATIONAL APPLICATION PUBLISHED UNDER THE PATENT COOPERATION TREATY (PCT)

(19) World Intellectual Property
Organization
International Bureau(10) International Publication Number
WO 2014/098762 A1(43) International Publication Date
26 June 2014 (26.06.2014)

(51) International Patent Classification:

E04F 15/02 (2006.01) *C09D 7/12* (2006.01)
B32B 27/18 (2006.01) *E04F 13/18* (2006.01)
B44C 5/04 (2006.01)

(21) International Application Number:

PCT/SE2013/051604

(22) International Filing Date:

20 December 2013 (20.12.2013)

(25) Filing Language:

English

(26) Publication Language:

English

(30) Priority Data:

1251483-2 21 December 2012 (21.12.2012) SE
 13/725,000 21 December 2012 (21.12.2012) US

(71) Applicant: **VÄLINGE PHOTOCATALYTIC AB**
[SE/SE]; Prästavägen 513, SE-263 65 Viken (SE).(72) Inventors: **JENSEN, Henrik**; Safirvej 10, DK-3650 Ølstykke (DK). **REENBERG, Theis**; Jægersborggade 49, 3, DK-2200 København (DK). **ZIEGLER, Göran**; Hästhovsvägen 11, SE-263 62 Viken (SE).(74) Agent: **WESTEMAN, Maria**; Välinge Innovation AB, Prästavägen 513, SE-263 65 Viken (SE).

(81) Designated States (unless otherwise indicated, for every kind of national protection available): AE, AG, AL, AM,

AO, AT, AU, AZ, BA, BB, BG, BH, BN, BR, BW, BY, BZ, CA, CH, CL, CN, CO, CR, CU, CZ, DE, DK, DM, DO, DZ, EC, EE, EG, ES, FI, GB, GD, GE, GH, GM, GT, HN, HR, HU, ID, IL, IN, IR, IS, JP, KE, KG, KN, KP, KR, KZ, LA, LC, LK, LR, LS, LT, LU, LY, MA, MD, ME, MG, MK, MN, MW, MX, MY, MZ, NA, NG, NI, NO, NZ, OM, PA, PE, PG, PH, PL, PT, QA, RO, RS, RU, RW, SA, SC, SD, SE, SG, SK, SL, SM, ST, SV, SY, TH, TJ, TM, TN, TR, TT, TZ, UA, UG, US, UZ, VC, VN, ZA, ZM, ZW.

(84) Designated States (unless otherwise indicated, for every kind of regional protection available): ARIPO (BW, GH, GM, KE, LR, LS, MW, MZ, NA, RW, SD, SL, SZ, TZ, UG, ZM, ZW), Eurasian (AM, AZ, BY, KG, KZ, RU, TJ, TM), European (AL, AT, BE, BG, CH, CY, CZ, DE, DK, EE, ES, FI, FR, GB, GR, HR, HU, IE, IS, IT, LT, LU, LV, MC, MK, MT, NL, NO, PL, PT, RO, RS, SE, SI, SK, SM, TR), OAPI (BF, BJ, CF, CG, CL, CM, GA, GN, GQ, GW, KM, ML, MR, NE, SN, TD, TG).

Declarations under Rule 4.17:

— as to applicant's entitlement to apply for and be granted a patent (Rule 4.17(ii))

Published:

— with international search report (Art. 21(3))

(54) Title: A METHOD FOR COATING A BUILDING PANEL AND A BUILDING PANEL

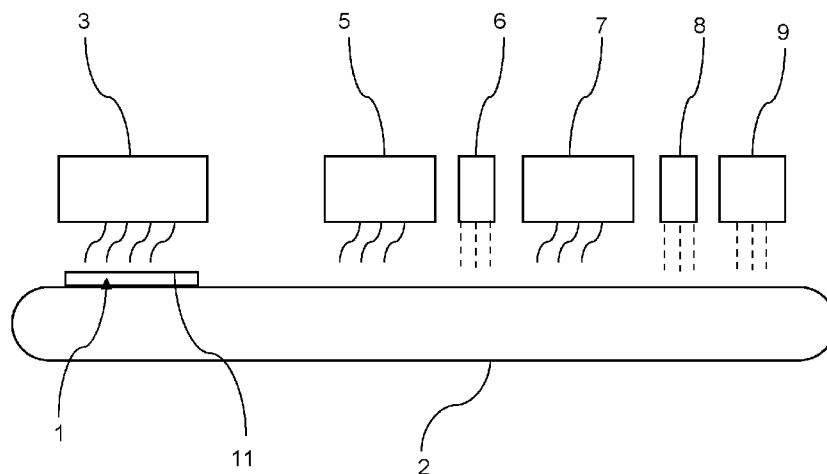

Fig. 1

(57) Abstract: The present disclosure relates to a method for coating a building panel (1, 1'), comprising applying a first coating fluid comprising an organic binder on a surface (11) of the building panel (1, 1') to obtain at least one coating layer (13), and applying barrier components and photocatalytic particles, preferably TiO₂, on said at least one coating layer (13). The invention also relates to such a building panel (1, 1').

WO 2014/098762 A1

A METHOD FOR COATING A BUILDING PANEL AND A BUILDING PANEL

Technical field

The disclosure generally relates to the field of building panels, such as floor panels, wall panels and furniture components, and a method of coating building panels with a
5 photocatalytic coating.

Background

For floor panels and wall panels, the visual appearance is very important. Furthermore, due to new regulations it is important to introduce properties that can reduce the level of indoor volatile organic compounds (VOC's).

10 It is well known that building materials can obtain photocatalytic properties. US 6,409,821 describes how to apply TiO_2 to external cement building materials by mixing micron sized TiO_2 in the bulk cement mixture.

Furthermore, it was shown in WO 2009/062516 that it is possible to apply nanoparticles on a laminate surface or on an overlay paper and introduce photocatalytic properties to
15 interior surfaces such as floor panels.

US 2010/0058954 describes a carbon-modified titanium dioxide film arranged on a substrate such as glass, metal, plastic or titanium dioxide film. A barrier layer may be arranged to prevent potential diffusion of sodium and other ions from the substrate into the carbon-modified titanium dioxide film. The photocatalytic activity can be inhibited by
20 diffusion of sodium and other ions from the substrate.

WO 2013/006125 describes a photocatalytic layer and a barrier layer.

It has also been discovered that the photocatalytic activity of the nanoparticles degrades not only volatile organic compounds but also underlying surfaces to which the nanoparticles are applied.

Objects of the Invention

An objective of at least certain embodiments of the present invention is to provide a building panel having improved washing properties thereby providing an overall cleaner looking floor.

- 5 An objective of at least certain embodiments of the present invention is to provide a building panel having improved VOC removing properties thereby providing an overall improved indoor environment.

Still another objective of at least certain embodiments is to provide a photocatalytic building panel having an improved antimicrobial effect and/or an improved deodorizing effect and/or an improved degradation of VOC effect and/or anti stain properties of said
10 building panel.

A still further objective of at least certain embodiments is to provide an active photocatalytic composition on building panels with minimal impact on the underlying coating layer.

- 15 A still further objective of at least certain embodiments is to provide an active photocatalytic composition on building panels with minimal impact on the underlying coating layer but still being active enough to provide improved VOC properties and/or washing properties at indoor light conditions.

A still further objective of at least certain embodiments is to provide coating compositions
20 to building panels without impacting the visual appearance of the building panels.

Furthermore, it can be an objective of at least certain embodiments of the present invention to provide a method for producing such photocatalytic building panels.

Summary

According to a first aspect of the invention, a method for coating a building panel is
25 provided. The method comprises applying a first coating fluid comprising an organic binder on a surface of the building panel to obtain at least one coating layer, and applying barrier components and photocatalytic particles, preferably TiO₂, on said at least one coating layer.

The photocatalytic particles are preferably photocatalytic nanoparticles, preferably nano-sized TiO₂.

The barrier components are adapted to prevent the photocatalytic particles from degrading the organic binder.

- 5 The surface comprises preferably a decorative surface of the building panel.

An advantage of the present invention is that a building panel having VOC reducing properties is obtained by the method. The building panel thus reduces the level of indoor volatile organic compounds (VOC's) by its photocatalytic activity. The photocatalytic activity of the photocatalytic particles also provides improved antimicrobial effect and
10 improved deodorizing effect, thereby contributing to an improved indoor environment.

A further advantage is that a building panel having improved washing properties is obtained. The surface of the building panel obtains hydrophilic properties due to the applied photocatalytic particles. The hydrophilic surface of the building panel facilitates cleaning by the fact that water applied forms a film instead of contracting droplets, and
15 thus dries faster and more uniformly. As a consequence, water stains from dirt or dissolved salts are reduced due to water being more uniformly distributed on the surface. The hydrophilic surface of the building panel has preferably a contact angle with water being less than 50°, preferably less than 40°.

A further advantage is that the photocatalytic activity of the building panel is maintained
20 as long as the surface of the building panel is maintained.

A further advantage is that the photocatalytic activity does not impact the underlying coating layer applied to the surface of the building panel. If photocatalytic particles are applied to a coating layer comprising an organic binder, such as a coating layer comprising an acrylate or methacrylate oligomer or monomer, an undesired effect of the
25 photocatalytic activity is that the photocatalytic particles react with the underlying coating layer, and the underlying coating layer can thereby be damaged by the photocatalytic activity of the particles. For example, the photocatalytic activity of the photocatalytic particles may degrade the underlying coating layer. The photocatalytic particles degrade the organic binder of the coating layer. The photocatalytic particles degrade bindings of
30 the organic binder, such as bindings obtained by the acrylate or methacrylate monomer or

oligomer. The photocatalytic activity can lead to that the coating layer is degraded into dust, thus affecting both functionality of the coating layer and the visual impression of the building panel. The photocatalytic particles may also impact other properties of the underlying coating layer, such as changing the colour of the coating layer.

- 5 By applying barrier components between the photocatalytic particles and the coating layer, the barrier components protect the coating layer from the photocatalytic activity of the photocatalytic particles. The barrier components preferably form at least one monolayer. The barrier components prevent the photocatalytic particles from make contact and react with the underlying coating layer. The barrier components prevent the
- 10 photocatalytic particles from degrading the organic binder, such as an acrylate or methacrylate monomer or oligomers, of the coating layer. The barrier components prevent the photocatalytic particles from degrade bindings made by the organic binder, such as bindings of the acrylate or methacrylate monomer or oligomer. Thereby, both functionality and mechanical properties of the coating layer and the visual impression of the coating
- 15 layer are maintained over time.

By applying barrier components, photocatalytic particles can be applied to any surface provided with a coating layer comprising an organic binder. Thus, photocatalytic properties can be provided on any surface provided with an organic coating layer.

- The photocatalytic particles are preferably photocatalytic nanoparticles. The photocatalytic
- 20 nanoparticles may have a size of less than 100 nm, preferably less than 50 nm, more preferably less than 30 nm, most preferably less than 20 nm, as measured when being present in the photocatalytic coating fluid. The photocatalytic particles comprise preferably TiO₂, preferably in anatase form. The photocatalytic particles are preferably visible light sensitive and/or UV light sensitive.

- 25 The barrier layer is preferably transparent. The photocatalytic layer is preferably transparent. Thereby, the visual impression of the building panel is not affected.

More than one coating layer may be applied to the surface of the building panel. The coating layers may have different properties and/or different appearance. One of the coating layers may be a base coating layer. Another of the coating layers may be a top

coating layer applied on the base coating layer. The coating layer may be a lacquer layer or varnish layer.

The barrier components may be at least partly embedded in one of the coating layers, for example at least partly embedded in a top coating layer.

5 The step of applying the barrier components and the photocatalytic particles may comprise applying a barrier coating fluid comprising the barrier components on said at least one coating layer to obtain a barrier layer, and applying a photocatalytic coating fluid comprising the photocatalytic particles on said barrier layer to obtain a photocatalytic layer. The barrier layer and the photocatalytic layer form an overlying layer.

10 The barrier layer is preferably at least one monolayer of the barrier components.

The organic binder may comprise an acrylate or methacrylate monomer, or an acrylate or methacrylate oligomer.

The acrylate or methacrylate monomer or acrylate or methacrylate oligomer may be an epoxy acrylate, an epoxy methacrylate, a urethane acrylate, a urethane methacrylate, a
15 polyester acrylate, a polyester methacrylate, a polyether acrylate, a polyether methacrylate, an acrylic acrylate, an acrylic methacrylate, a silicone acrylate, a silicone methacrylate, a melamine acrylate, a melamine methacrylate, or a combination thereof. The above examples are examples of monomer or oligomers polymerised by radical
20 reaction. The above monomers or oligomers may form a component of the coating fluid.

The oligomers contribute to the final properties of the coating layer.

The first coating fluid may be a radiation curing coating fluid, preferably UV curing coating fluid. Electron beam curing is also contemplated.

The method may further comprise partly curing said at least one coating layer, preferably by radiation curing, more preferably by UV curing, prior to applying the barrier
25 components and the photocatalytic particles. Preferably, the barrier coating fluid is applied to the coating layer before gelation of the coating layer, or at least before complete gelation of the coating layer. Thereby, influence on the visual impression of the coating layer by the barrier components is reduced. Furthermore, by applying the barrier components to the coating layer before gelation of the coating layer, the barrier

components may be at least partly embedded in the underlying coating layer. By applying the barrier components in an at least partly wet surface the distribution of the particles may be improved.

5 The surface of the building panel may comprise wood, wood veneer, wood-based board, cork, linoleum, thermoplastic material, thermosetting material, or paper. The building panel may be a wood panel, a wood based panel, a panel having a surface of wood veneer, a linoleum building panel, a cork building panel, a thermoplastic floor panel such as a Luxury Vinyl Tile or Plank. The building panel may for example be a floor panel, a wall panel, a ceiling panel, a furniture component etc.

10 The method may further comprise drying said barrier layer, prior to applying the photocatalytic coating fluid. The drying may be performed by means of IR.

The method may further comprise drying the photocatalytic layer. The drying may be performed by means of IR.

15 The method may further comprise curing said at least one coating layer, said overlying layer, said barrier layer and/or said photocatalytic layer. Preferably, said at least one coating layer is completely cured together with the barrier layer and the photocatalytic layer in a final step.

20 The concentration of the photocatalytic particles in the photocatalytic fluid may be up to about 30 wt %, preferably up to about 20 wt %, more preferably up to about 10 wt%, most preferably up to about 5 wt %.

The concentration of the barrier components in the barrier coating fluid may be up to about 40 wt %, such as about 30 wt %, preferably up to about 20 wt%, such as about 10 wt%, for example up to about 5 wt %.

25 The thickness of the barrier layer may be up to about 1 μm , preferably up to about 0.600 μm , more preferably up to about 0.400 μm , most preferably up to about 0.100 μm .

The thickness of the photocatalytic layer may be up to about 1 μm , preferably up to about 0.600 μm , more preferably up to about 0.400 μm , most preferably up to about 0.100 μm .

The amount of the barrier and/or photocatalytic coating fluid(s) applied may be up to about 50 ml/m², preferably up to about 40 ml/m², more preferably up to about 30 ml/m², and most preferably up to about 20 ml/m². In one embodiment, the amount of the barrier and/or photocatalytic coating fluid(s) applied may be up to about 15 ml/m², preferably up to about 10 ml/m², more preferably up to about 5 ml/m², and most preferably up to about 1 ml/m².

The concentration of the barrier components in the barrier layer may be at least 70%, more preferably at least 80% and most preferably at least 90%. In one embodiment, the barrier layer substantially consists of the barrier components. By substantially consist is meant that additives and a binder may be present in small amount compared to the amount of the barrier components.

The barrier and/or photocatalytic coating fluid(s) may be aqueous/waterborne fluids. The barrier and/or the photocatalytic coating fluid(s) may also be a hybrid system, comprising both physically dryable and curable parts. It is also contemplated that a solvent other than water is used.

The barrier and/or photocatalytic coating fluid(s) may be applied by spraying.

The size of the droplet of said barrier and/or photocatalytic coating fluids may be up to about 200 μm , preferably up to about 100 μm , more preferably up to about 50 μm , and most preferably up to about 10 μm . If the size of the droplets exceeds about 200 μm , individual droplets may be visible on the surface, resulting in an aesthetically less pleasant coating. By diminishing the size of the droplets, a coating having an even surface is obtained, with no, or at least reduced, visible droplets.

The barrier components may comprise a silicium containing compound such as SiO₂, colloidal SiO₂, functional nanoscaled SiO₂, silicone resin, organofunctional silanes, and/or colloidal silicic acid silane and/or a combination of said compounds. Silicium containing compounds prevent bonding caused by the organic binder of the coating layer, for example bonding between the acrylate or methacrylate monomers or oligomers, to be degraded by the photocatalytic activity. The barrier components may be particles, fibres, oligomers, polymers etc. The barrier components may be may have a size in the nano

range, for example less than 400 nm such as 300-400 nm. In one embodiment, the barrier components may be less than 100 nm.

The photocatalytic coating fluid may comprise photocatalytic particles and a solvent, said solvent being selected from water, ethylene glycol, butyl ether, aliphatic linear, branched
5 or cyclic or mixed aromatic-aliphatic alcohols, such as methanol, ethanol, propanol, isopropanol, butanol, isobutanol, benzyl alcohol or methoxypropanol or combinations thereof. The barrier coating fluid may comprise barrier components and a solvent, said solvent being selected from water, ethylene glycol, butyl ether, aliphatic linear, branched
10 or cyclic or mixed aromatic-aliphatic alcohols, such as methanol, ethanol, propanol, isopropanol, butanol, isobutanol, benzyl alcohol or methoxypropanol or combinations thereof.

According to a second aspect of the invention, a building panel is provided. The building panel comprising a surface provided with at least one radiation cured coating layer comprising an organic binder, wherein said at least one coating layer is arranged on said
15 surface, and at least one overlying layer comprising barrier components and photocatalytic particles, preferably TiO₂, wherein the barrier components prevent the photocatalytic particles from degrading the organic binder of said at least one coating layer, and wherein said at least one overlying layer is arranged on said at least one coating layer.

The surface comprises preferably a decorative surface of the building panel.

20 An advantage of the second aspect of invention is that the building panel has VOC reducing properties. The building panel thus reduces the level of indoor volatile organic compounds (VOC's) by its photocatalytic activity. The photocatalytic activity of the photocatalytic particles also provides improved antimicrobial effect and improved deodorizing effect, thereby contributing to an improved indoor environment.

25 A further advantage is that the inventive building panel has improved washing properties. The surface of the building panel obtains hydrophilic properties due to the applied photocatalytic particles. The hydrophilic surface of the building panel facilitates cleaning by the fact that water applied forms a film instead of contracting droplets, and thus dries faster and more uniformly. As a consequence, water stains from dirt or dissolved salts are
30 reduced due to water being more uniformly distributed on the surface. The hydrophilic

surface of the building panel has preferably a contact angle with water being less than 50°, preferably less than 40°.

A further advantage is that the photocatalytic activity of the building panel is maintained as long as the surface of the building panel is maintained.

- 5 A further advantage is that the photocatalytic activity does not impact the underlying coating layer applied to the surface of the building panel. If photocatalytic particles are applied to a coating layer comprising an organic binder, such as a coating layer comprising an acrylate or methacrylate monomer or oligomer, an undesired effect of the photocatalytic activity is that the photocatalytic particles react with an underlying coating layer, and the underlying coating layer can thereby be damaged by the photocatalytic activity of the particles. For example, the photocatalytic activity of the photocatalytic particles may degrade the underlying coating layer. The photocatalytic particles degrade the organic binder of the coating layer. The photocatalytic particles degrade bindings of the organic binder, such as bindings of the acrylate or methacrylate monomer or oligomer.
- 10
- 15 The photocatalytic activity can lead to that the coating layer is degraded into dust, thus affecting both functionality of the coat layer and the visual impression of the building panel. The photocatalytic particles may also impact other properties of the underlying coating layer, such as changing the colour of the coating layer.

- By applying barrier components between the photocatalytic particles and the underlying coating layer, the barrier components protect the underlying coating layer from the photocatalytic activity of the photocatalytic particles. The barrier components prevent the photocatalytic particles from make contact and react with the underlying coating layer. The barrier components prevent the photocatalytic particles from degrading the organic binder, such as acrylate or methacrylate monomers or oligomers, of the underlying coating layer. The barrier components prevent the photocatalytic particles from degrade bindings of the organic binder comprising for example acrylate or methacrylate monomer or oligomer. Thereby, both functionality and mechanical properties of the coating layer and the visual impression of the coating layer are maintained over time.
- 20
- 25

By applying barrier components, photocatalytic particles can be applied to any surface provided with an organic coating layer. Thus, photocatalytic properties can be provided on any surface provided with an organic coating layer.

The photocatalytic particles are preferably photocatalytic nanoparticles. The photocatalytic nanoparticles may have a size of less than 100 nm, preferably less than 50 nm, more preferably less than 30 nm, and most preferably less than 20 nm, as measured when being present in the photocatalytic coating fluid. The photocatalytic particles comprise preferably TiO₂, preferably in anatase form. The photocatalytic particles are preferably visible light sensitive and/or UV sensitive photocatalytic particles.

10 The organic binder may comprise an acrylate or methacrylate monomer, or an acrylate or methacrylate oligomer.

The acrylate or methacrylate monomer or acrylate or methacrylate oligomer may be an epoxy acrylate, an epoxy methacrylate, a urethane acrylate, a urethane methacrylate, a polyester acrylate, a polyester methacrylate, a polyether acrylate, a polyether methacrylate, an acrylic acrylate, an acrylic methacrylate, a silicone acrylate, a silicone methacrylate, a melamine acrylate, a melamine methacrylate, or a combination thereof. The above examples are examples of monomer or oligomers polymerised by radical reaction.

20 Said at least one coating layer may comprise a radiation curable coating, preferably a UV curable coating.

The surface of the building panel may comprise wood, wood veneer, wood-based board, cork, linoleum, thermoplastic material, thermosetting material, or paper. The building panel may be a wood panel, a wood based panel, a panel having a surface layer of wood veneer, a linoleum building panel, a cork building panel, a thermoplastic floor panel such as a Luxury Vinyl Tile or Plank. The building panel may for example be a floor panel. The surface layer may be arranged on a core.

The overlying layer may be transparent. Thereby, the visual impression of the building panel is not affected by the overlying layer.

More than one coating layer may be arranged on the surface of the building panel. The coating layers may have different properties and/or different appearance. One of the coating layers may be a base coating layer. Another of the coating layers may be a top coating layer applied on the base coating layer. The coating layer may be a lacquer layer or
5 varnish layer.

The barrier components may be at least partly embedded in one of the coating layers, for example embedded in a top coating layer.

The photocatalytic particles may be embedded in the overlying layer. The barrier components may be embedded in the overlying layer.

10 Said at least one overlying layer may comprise a barrier layer comprising the barrier components and a photocatalytic layer comprising the photocatalytic particles, wherein the barrier layer is arranged between said at least one coating layer and the photocatalytic layer. Preferably, the barrier components are embedded and substantially homogeneously distributed in said barrier layer. Preferably, the photocatalytic particles are embedded and
15 substantially homogeneously distributed in the photocatalytic layer. Preferably, the barrier layer is formed of at least one monolayer of the barrier components. The barrier layer and the photocatalytic layer are preferably transparent.

An area of mixed barrier and photocatalytic particles may be provided between the barrier layer and the photocatalytic layer.

20 The barrier components may comprise a silicium containing compound such as SiO₂, colloidal SiO₂, functional nanoscaled SiO₂, silicone resin, organofunctional silanes, and/or colloidal silicic acid silane and/or a combination of said compounds. The barrier components may be particles, fibres, oligomers, polymers etc. The barrier components may be may have a size in the nano range, for example less than 400 nm such as 300-
25 400 nm. In one embodiment, the barrier components may have a size less than 100 nm.

The concentration of the barrier components in the barrier layer may be at least 70%, more preferably at least 80% and most preferably at least 90%. In one embodiment, the barrier layer substantially consists of the barrier components. By substantially consist is meant that additives and a binder may be present in small amount compared to the
30 amount of the barrier components.

The building panel may be a floor panel, a wall panel, a ceiling panel, a furniture component etc. The floor panel may be provided with a mechanical locking system at at least one of its edges for vertical and/or horizontal locking to another floor panel.

5 A third aspect of the invention is a building panel produced by the method according to the first aspect.

According to another aspect of the present invention, there is provided a method for coating a building panel comprising: applying a first coating fluid comprising an organic binder on a surface of the building panel to obtain at least one coating layer; applying a barrier coating fluid comprising a solvent and barrier components, the
10 barrier coating fluid including at least 5 wt % of at least one silicon containing compound, on said at least one coating layer to obtain a barrier layer; and applying a photocatalytic coating fluid comprising photocatalytic particles on said barrier layer to obtain a photocatalytic layer, wherein the organic binder comprises an acrylate or methacrylate monomer, or an acrylate or methacrylate oligomer.

15 According to another aspect of the present invention, there is provided a method for coating a building panel comprising: applying a first coating fluid comprising an organic binder on a surface of the building panel to obtain at least one coating layer; applying a barrier coating fluid comprising a solvent and barrier components on said at least one coating layer to obtain a liquid barrier layer; drying said liquid barrier
20 layer to obtain a barrier layer consisting essentially of at least one silicon containing compound; and applying a photocatalytic coating fluid comprising the photocatalytic particles on said barrier layer to obtain a photocatalytic layer, wherein the organic binder comprises an acrylate or methacrylate monomer, or an acrylate or methacrylate oligomer.

25 Brief Description of the Drawings

The present invention will by way of example be described in more detail with reference to the appended schematic drawings, which show embodiments of the present invention.

Fig. 1 illustrates a method for coating a building panel according to one embodiment of the invention.

Fig. 2a illustrates a wooden building panel according to one embodiment of the invention.

5 Fig. 2b illustrates a wooden building panel according to one embodiment of the invention.

Fig. 3a illustrates a thermoplastic building panel according to one embodiment of the invention.

10 Fig. 3b illustrates a thermoplastic building panel according to one embodiment of the invention.

Fig. 4a illustrates a linoleum building panel according to one embodiment of the invention.

Fig. 4b illustrates a linoleum building panel according to one embodiment of the invention

15 Detailed Description

A method for coating a building panel will now be described with reference to fig. 1.

20 Fig. 1 illustrates a coating process for a building panel in a coating line. The building panel 1 may be a floor panel, a wall panel, a furniture component etc. The building panel 1 may be solid or may comprise more than one layer, i.e. such as a laminated panel. The first coating fluid is applied on a surface 11 of the building panel 1 adapted to face an interior space of a room, for example as an upper surface of a floor panel. The surface 11 comprises preferably a decorative surface of the building panel. The surface 11 provides the building panel with its decorative properties. The surface 11 of the building panel 1 may comprises

a wood based material such as solid wood, wood veneer, a wood fibre based board. The decorative surface of the building panel 1 may comprises cork, linoleum, thermoplastic material, thermosetting material or paper.

The coating line comprises several application apparatus and a conveyor belt 2 adapted to convey the building panel 1. The conveyor belt 2 preferably conveys the building panel 1 at a constant speed.

In the coating line, a first coating fluid is applied to the surface 11 of a building panel 1 by a coating apparatus 3. The first coating fluid is preferably applied on the surface 11 of the building panel 1 by means of spraying, roller coating etc. The first coating fluid is preferably uniformly applied to the surface 11 of the building panel 1. The first coating fluid is applied such that at least one coating layer is formed on the surface 11 of the building panel 1. The coating layer is preferably continuous. The coating layer covers preferably the entire surface 11 of the building panel 1. The coating layer may be a lacquer layer or varnish layer. The coating layer is adapted to protect the surface 11 of the building panel, which preferably is a decorative surface. The coating layer is adapted to give the surface 11 wear resistant properties.

The coating layer may comprise one or several layers, for example a base coating layer and a top coating layer. A person skilled in the art realises that also the base coating layer and/or the top coating layer may comprise one or more layers. In fig. 1, only one coating apparatus 3 is shown. A person skilled in the art appreciates that if more than one layer is to be applied, more than one coating apparatus 3 may be provided or the building panel may pass the coating apparatus 3 more than one time. The base coating layer may be cured before applying a top coating layer.

The coating fluid comprises an organic binder. The organic binder preferably comprises an acrylate or methacrylate monomer or an acrylate or methacrylate oligomer. The acrylate or methacrylate monomer or oligomer may be an epoxy acrylate, an epoxy methacrylate, a urethane acrylate, a urethane methacrylate, a polyester acrylate, a polyester methacrylate, a polyether acrylate, a polyether methacrylate, an acrylic acrylate, an acrylic methacrylate, a silicone acrylate, a silicone methacrylate, a melamine acrylate, a melamine methacrylate,

or a combination thereof. In another embodiment, the organic binder comprises an unsaturated polyester.

The above examples are examples of monomers and oligomers polymerised by radical reaction.

- 5 The above monomers and oligomers form a component of the coating fluid. The coating fluid may further comprise initiators such as photo-initiators, pigments, fillers, amine synergists, reactive diluents, wetting agent, additives etc. The coating fluid may be a waterborne, solvent borne, or 100 % UV dispersion.

The coating fluid may be a radiation curing coating fluid, preferably UV curing coating fluid
10 or electron beam curing coating fluid. Preferably, the coating fluid comprises an urethane based acrylate monomer or oligomer.

In one embodiment (not shown), the at least one coating layer may be at least partly cured by a curing device, for example a UV lamp. By partly cured is meant that the coating layer is gelled but not completely cured. If more than one coating layer has been applied to the
15 building panel 1, the underlying coating layers may already have been cured but the uppermost coating layer may be wet or partly cured.

Barrier components are thereafter applied to the building panel 1 by means of an application device 5. The barrier components are adapted to prevent photocatalytic particles from degrading the organic binder of the coating layer. The barrier components
20 comprise silicium containing compound. Examples of such a silicium containing compound are SiO₂, colloidal SiO₂, functional nanoscaled SiO₂, silicone resin, organofunctional silanes, and/or colloidal silicic acid silane and/or a combination of said compounds.

The barrier components are preferably applied as a barrier coating fluid comprising the barrier components. In the shown embodiment, the barrier coating fluid is applied wet-in
25 wet, i.e. the underlying coating layer is not cured before application of the barrier coating fluid. The barrier coating fluid is preferably a waterborne dispersion having the barrier components dispersed therein. The barrier coating fluid may further comprise a wetting agent such as a non-ionic surfactant and/or other additives. The barrier coating fluid may be heat curing. The amount of the barrier coating fluid may be up to about 50 ml/m²,
30 preferably up to about 40 ml/m², more preferably up to about 30 ml/m², and most

preferably up to about 20 ml/m². In one embodiment, the amount of said barrier coating fluid applied is up to about 15 ml/m², up to about 10 ml/m², up to about 5 ml/m², up to about 1 ml/m².

In the shown embodiment, the barrier coating fluid is applied by spraying on the coating layer by a spraying device 5. The size of the droplet of the barrier coating fluid is up to about 200 μm, up to about 150 μm, up to about 100 μm, up to about 50 μm, up to about 25 μm or up to about 10 μm.

The concentration of the barrier components in the barrier coating fluid may be up to about 40 wt %, such as about 30 wt %, preferably up to about 20 wt%, such as about 10 wt%, for example up to about 5 wt %.

The barrier coating fluid forms a barrier layer on the coating layer. If more than one coating layer is provided, the barrier layer is arranged on the top coating layer. Preferably, the barrier layer is at least one monolayer of barrier components. The barrier layer is preferably continuous over the coating layer. The barrier components may be at least partly embedded in the coating layer. The thickness of the barrier layer may be up to about 1 μm, up to about 0.800 μm, up to about 0.600 μm, up to about 0.400 μm, up to about 0.200 μm, up to about 0.100 μm or up to about 0.05 μm.

If the coating layer is not cured before applying the barrier components, or only partly cured or semi-cured, the barrier components may engage with the underlying coating layer. The underlying coating layer and the barrier layer may not be completely separate. A portion where the coating layer and the barrier layer are mixed may be formed.

In a preferred embodiment, the barrier layer is dried before applying the photocatalytic particles. In fig. 1, a heating apparatus 6, preferably an IR heating apparatus, is arranged after the spraying device 5 adapted to spray the barrier coating fluid.

The concentration of the barrier components in the barrier layer may be at least 70%, more preferably at least 80% and most preferably at least 90%. In one embodiment, the barrier layer substantially consists of the barrier components. By substantially consist is meant that additives and a binder may be present in a small amount compared to the amount of the barrier components.

Photocatalytic particles are thereafter applied on the barrier layer. The photocatalytic particles are preferably photocatalytic nanoparticles, more preferably TiO₂. The photocatalytic particles may have a size of less than 100 nm, preferably less than 50 nm, more preferably less than 30 nm, most preferably less than 20 nm, as measured when
5 being present in the photocatalytic coating fluid.

Preferably, the photocatalytic particles are applied as a photocatalytic coating fluid comprising the photocatalytic particles. The photocatalytic coating fluid may be a waterborne dispersion having the photocatalytic particles dispersed therein. The photocatalytic coating fluid may further comprise a wetting agent such as a non-ionic
10 surfactant and/or other additives. The photocatalytic coating fluid may be heat curing. The concentration of the photocatalytic particles may be up to about 30 wt %, up to about 20, wt %, up to about 10 wt%, up to about 5 wt %, or up to about 1 wt %. The amount of the photocatalytic coating fluid applied may be up to about 50 ml/m², preferably up to about 40 ml/m², more preferably up to about 30 ml/m², and most preferably up to about 20
15 ml/m². In one embodiment, the amount of the photocatalytic coating fluid applied is up to about 15 ml/m², up to about 10 ml/m², up to about 5 ml/m², up to about to 1 ml/m².

The photocatalytic coating fluid may comprise an additive such as a wetting agent, preferably a non-ionic surfactant, in a concentration determined relative the concentration of photocatalytic particles in the photocatalytic coating fluid. In the photocatalytic coating
20 fluid, the weight ratio (weight/weight) between the wetting agent such as a non-ionic surfactant and the photocatalytic particles may be 0,01-0,04, preferably 0,02-0,03.

In the shown embodiment, the photocatalytic coating fluid is applied by spraying on the barrier layer by a spraying device 7. The size of the droplet of the photocatalytic coating fluid is up to about 200 μm, up to about 150 μm, up to about 100 μm, up to about 50 μm,
25 up to about 25 μm or up to about 10 μm.

The photocatalytic coating fluid applied forms a photocatalytic layer arranged on the barrier layer. The photocatalytic layer is preferably continuous over the barrier layer. The thickness of the photocatalytic layer may be up to about 1 μm, preferably up to about 0.800 μm, more preferably up to about 0.600 μm, most preferably up to about 0.400 μm,
30 up to about 0.200 μm, up to about 0.100 μm or up to about 0.05 μm.

The underlying barrier layer and the photocatalytic layer may not be completely separated. A portion where the coating layer and the barrier layer are mixed may be formed. An area of mixed barrier and photocatalytic particles may be provided in the border between the barrier layer and the photocatalytic layer. A part of the photocatalytic particles may be partly embedded by the barrier particles in the border between the barrier layer and the photocatalytic layer.

The photocatalytic layer is preferably dried, for example by a heating apparatus 8, preferably an IR heating apparatus, as shown in fig. 1.

The at least one coating layer, the barrier layer and the photocatalytic layer are then cured in a curing apparatus 9. The coating layer may be completely cured by radiation curing, preferably UV curing or electron beam curing. In the embodiment shown in fig. 1, the curing apparatus comprises an UV lamp 9 for curing the coating layer. The barrier layer and the photocatalytic layer are completely dried. Thereby, a building panel 1 having photocatalytic properties is obtained. The building panel 1 comprises a surface 11 provided with at least one coating layer, and an overlying layer comprising the barrier layer and the photocatalytic layer.

A building panel 1 having photocatalytic properties will now be described with reference to figs. 2a and b. The building panel 1 is preferably coated according to the method described above. The building panel 1 is a wooden panel, for example a wall panel, a floor panel, a furniture component. The building panel 1 may be of solid wood 12 as shown in figs. 2a and 2b. Alternatively, the building panel 1 may comprise a core provided with a surface layer of wood, for example a veneer layer (not shown). The building panel 1 may also be a wood-based panel, such as a MDF, HDF, OSB or particleboard. The building panel 1 may be a floor panel.

A surface 11 of the wooden building panel 1 is provided with at least one coating layer 13 and an overlying layer 14, preferably applied by above described method. The coating layer 13 comprising an organic binder of the above described type. The coating layer 13 may be a lacquer layer or a varnish layer. Preferably, the coating layer 13 comprises at least one base coating layer 13a and a least one top coating layer 13b as shown in figs 2a

and 2b. The coating fluid comprises preferably a urethane based acrylate. The coating fluid is preferably UV curable.

In fig. 2a, the overlying layer 14 is arranged on the top coating layer 13. The overlying layer 14 comprises a barrier layer 14a and a photocatalytic layer 14b. The barrier layer 14a
5 comprises barrier components of the above described type. The barrier layer 14a is arranged on the top coating layer 13b. The photocatalytic layer 14b comprising photocatalytic particles is arranged on the barrier layer 14a. The photocatalytic particles are of the above described type.

In fig. 2b, the overlying layer 14 is arranged on the top coating layer 13b. The overlying
10 layer 14 comprises barrier components of the above described type and photocatalytic particles of the above described type. The barrier components and the photocatalytic particles are at least partly mixed. The overlying layer 14 comprises a lower part wherein the concentration of the barrier components is higher than the concentration of photocatalytic particles. The overlying layer 14 comprises an upper part wherein the
15 concentration of the photocatalytic particles is higher than the concentration of barrier components. A mixed area may be provided comprising both barrier components and photocatalytic particles.

Figs. 3a and 3b illustrate a building panel 1 in form of a floor panel 1'. The floor panel 1' is preferably coated according to the above described method. The floor panel 1' may be a
20 Luxury Vinyl Tile (LVT) or Luxury Vinyl Plank. The floor panel 1' comprises a core 15, at least one surface layer 16, 17, at least one coating layer 13 and an overlying layer 14. A backing layer (not shown) may also be provided on the lower side of the core. The surface layer may comprise a décor layer 16 and a protective layer 17. A person skilled in the art appreciates that layers may be excluded, such as the protective layer and/or decorative
25 layer. The core 15 comprises thermoplastic material. The thermoplastic material may be polyvinyl chloride (PVC) or polypropylene (PP). The core may further comprise a filler, for example calcium carbonate, and additives such as plasticizer, impact modifier, stabilizer, processing aids, pigment, lubricants etc. Alternatively, the core 15 may be a Wood Plastic Composite (WPC) comprising a thermoplastic binder and wood fibres. The surface layer,
30 such as a décor layer 16 comprises a thermoplastic material such as polyvinyl chloride (PVC), polyester, polypropylene (PP), polyethylene (PE), polystyrene (PS), polyurethane

(PUR), or polyethylene terephthalate (PET). The décor layer 16 may further comprise additives such as a plasticizer. The décor layer 16 may be in form of a film or foil. The décor layer 16 preferably has a decorative print printed thereon. The protective layer 17 may be in form of a thermoplastic foil or film. The protective layer 17 comprises a thermoplastic material such as polyvinyl chloride (PVC), polyester, polypropylene (PP), polyethylene (PE), polystyrene (PS), polyurethane (PUR), or polyethylene terephthalate (PET). The protective layer 17 may further comprise additives such as a plasticizer.

The surface layer, for example the décor layer 16 or the protective layer 17, is provided with at least one coating layer 13 and an overlying layer 14, preferably applied by above described method. The coating layer 13 comprising an organic binder of the above described type. The coating layer 13 may be a lacquer layer or a varnish layer. The coating layer 13 may comprise at least one base coating layer and a least one top coating layer (not shown). The coating fluid comprises preferably a urethane based acrylate. The coating fluid is preferable UV curable. It is also contemplated that the coating fluid may be applied directly on the décor layer 16, or directly on the core 15.

In fig. 3a, the overlying layer 14 is arranged on the coating layer 13. The overlying layer 14 comprises a barrier layer 14a and a photocatalytic layer 14b. The barrier layer 14a comprises barrier components of the above described type. The barrier layer 14a is arranged on the coating layer 13. The photocatalytic layer 14b comprising photocatalytic particles is arranged on the barrier layer 14a. The photocatalytic particles are of the above described type.

In fig. 3b, the overlying layer 14 is arranged on the coating layer 13. The overlying layer 14 comprises barrier components of the above described type and photocatalytic particles of the above described type. The barrier components and the photocatalytic particles are at least partly mixed. The overlying layer 14 comprises a lower part wherein the concentration of the barrier components is higher than the concentration of photocatalytic particles. The overlying layer 14 comprises an upper part wherein the concentration of the photocatalytic particles is higher than the concentration of barrier components. A mixed area may be provided comprising both barrier components and photocatalytic particles.

Figs. 4a and 4b illustrate a building panel 1 in form of a floor panel 1'. The floor panel 1' is preferably coated according to the above described method. The floor panel 1' is a linoleum floor panel. The floor panel 1' may be of solid linoleum, or may be as shown in figs. 4a and b comprise a core 18 and a surface layer 19 of linoleum. The core 18 may be a wood based panel such as MDF or HDF. A backing layer (not shown), for example a cork layer, may be arranged on a lower side of the core. The linoleum surface layer 19 may comprise wood flour, linseed oil, binder, a filler such as calcium carbonate and pigments.

The linoleum surface layer 19 is coated by at least one coating layer 13 and an overlying layer 14 comprising barrier components and photocatalytic particles, preferably by the above described method. In figs. 4a and 4b, the coating layer 13 comprises a base coating layer 13a and a top coating layer 13b. The coating layer 13 comprises an organic binder of the above described type. The coating layer 13 may be a lacquer layer or a varnish layer. The coating fluid comprises preferably a urethane based acrylate. The coating fluid is preferable UV curable.

The overlying layer 14 is arranged on top of the top coating layer 13b. In the embodiment shown in fig. 4a, the overlying layer 14 comprises a barrier layer 14a and a photocatalytic layer 14b. The barrier layer 14a comprises barrier components of the above described type. The barrier layer 14a is applied on the top coating layer 13b. The photocatalytic layer 14b is applied on the barrier layer 14a. The photocatalytic layer 14b comprises photocatalytic particles of the above described type.

In fig. 4b, the overlying layer 14 is arranged on top of the top coating layer 13b. The overlying layer 14 comprises barrier components of the above described type and photocatalytic particles of the above described type. The barrier components and the photocatalytic particles are at least partly mixed. The overlying layer 14 comprises a lower part wherein the concentration of the barrier components is higher than the concentration of photocatalytic particles. The overlying layer 14 comprises an upper part wherein the concentration of the photocatalytic particles is higher than the concentration of barrier components. A mixed area may be provided comprising both barrier components and photocatalytic particles.

The floor panel 1' shown in fig. 4a and 4b is provided with a mechanical locking system. The floor panel 1' is provided with a mechanical locking system for locking the floor panel 1' to adjacent floor panels horizontally and/or vertically. The mechanical locking system comprises at a first edge of the floor panel a tongue groove 26 adapted to receive a tongue 5 25 of an adjacent floor panel, and a locking strip 22 provided with a locking element 23 adapted to cooperate with a locking groove 24 of an adjacent floor panel and lock the floor panel 1' in a horizontal direction to the adjacent floor panel. The mechanical locking system further comprises at a second edge a locking groove 24 adapted to receive a locking element 23 of an adjacent floor panel, and a tongue 25 adapted cooperate with a 10 tongue groove 26 of an adjacent floor panel and lock the panel 1' in a vertical direction. The mechanical locking system is formed in the core 18 of the floor panel 1'. Both long side edges and short side edges of the floor panel 1' may be provided with a mechanical locking system. Alternatively, long side edges of the floor panel 1' may be provided with the mechanical locking system for horizontally and vertically locking, and the short side edges 15 may be provided with a mechanical locking system for horizontally locking only. It is also contemplated that other locking systems may be used, for example of the type disclosed in WO2007/015669.

Any of the building panels described above with reference to figs. 2a-b and figs. 3a-b may be provided with a mechanical locking system as described above with reference to fig. 4a 20 and 4b.

It is contemplated that there are numerous modifications of the embodiments described herein, which are still within the scope of the invention as defined by the appended claims. For example, in the figures, said at least one coating layer and the overlying layer are shown as separate layers. However, it is contemplated that the layers may not be present 25 as separate layers and may be at least partly integrated into for example the underlying coating layer.

Examples

LVT – reference 1

A coating layer in form of 9 g/m² of a UV-curing lacquer was applied on a Luxury Vinyl Tile 30 (LVT) comprising a core, a décor layer and a protective layer. The coating layer was applied

on the protective layer. The UV-curing lacquer was cured at a speed of 10 m/min. Two mercury lamps were used both having a light effect of 120 W.

The product produced was put under UV light and checked for hydrophilicity. After 1 week in UV light the product showed a hydrophobic behaviour.

5 **LVT – reference 2**

A coating layer in form of 9 g/m² of a UV-curing lacquer was applied on a Luxury Vinyl Tile (LVT) comprising a core, a décor layer and a protective layer. The coating layer was applied on the protective layer. 5 g of a photocatalytic coating fluid comprising 1.5 wt-% nanofluid comprising photocatalytic nanoparticles, wherein the nanofluid is of the type described in
10 patent application WO 2010/110726, and 0.5 wt-% BYK-348 was applied on the UV coating layer. The UV-curing lacquer was cured at a speed of 10 m/min. Two mercury lamps were used both having a light effect of 120 W.

The product produced was put under UV light and checked for hydrophilicity. After 1 week in UV light the product showed a hydrophilic behaviour. However, the product has started
15 to chalk, since the photocatalytic particles have started to degrade the organic binder of the UV-curing coating layer.

LVT – with barrier layer and photocatalytic layer

A coating layer in form of 9 g/m² of a UV-curing lacquer was applied on a Luxury Vinyl Tile (LVT) comprising a core, a décor layer and a protective layer. The coating layer was applied
20 on the protective layer. 5 g of a barrier coating fluid comprising 5 wt-% SiO₂ as barrier components was sprayed into the UV-curing lacquer. 5 g of a photocatalytic coating fluid comprising 1.5 wt-% nanofluid comprising photocatalytic nanoparticles, wherein the nanofluid is of the type described in patent application WO 2010/110726, and 0.5 wt-% BYK-348 was applied on the barrier coating. The UV-curing lacquer, the barrier coating
25 fluid and the photocatalytic coating fluid were cured at a speed of 10 m/min. Two mercury lamps were used at 120 W each.

The product produced was put under UV light. After 1 week in UV light the product showed a hydrophilic behaviour with no deterioration of the lacquer.

Linoleum – reference 1

A base coating layer in form of a 20-30 g/m² of a UV-curing base coating lacquer was applied on a linoleum floor panel comprising a core and a surface layer of linoleum. The UV-curing base coating lacquer was applied on the surface layer of linoleum. A top coating layer in form of 20-30 g/m² of a UV-curing top coating lacquer was applied on top of the base coating layer. The UV-curing lacquers were cured at a speed of 10 m/min using an Hg and a Ga lamp at 120 W.

The produced product was put under UV light. After 1 week in UV light the product showed a hydrophobic behaviour.

Linoleum – reference 2

10 A base coating layer in form of a 20-30 g/m² of a UV-curing base coating lacquer was applied on a linoleum floor panel comprising a core and a surface layer of linoleum. The UV-curing base coating lacquer was applied on the surface layer of linoleum. A top coating layer in form of 20-30 g/m² of a UV-curing top coating lacquer was applied on top of the base coating layer. 5 g of a photocatalytic coating fluid comprising 5 wt-% nanofluid
15 comprising photocatalytic nanoparticles, wherein the nanofluid is of the type described in patent application WO 2010/110726, and 0.5 wt-% BYK-348 on the UV curing lacquer. The UV-curing lacquers were cured at a speed of 10 m/min using an Hg and a Ga lamp at 120 W. The produced product was put under UV light.

After 1 week in UV light the product showed a hydrophilic behaviour. The product has
20 started to chalk, since the photocatalytic particles have started to degrade the organic binder of the UV-curing lacquer.

Linoleum – with barrier layer and photocatalytic layer

A base coating layer in form of 20-30 g/m² of a UV-curing base coating lacquer was applied on a linoleum floor panel comprising a core and a surface of linoleum. The UV-curing base
25 coating lacquer was applied on the surface layer of linoleum. A top coating layer in form of 20-30 g/m² of a UV-curing toping coat lacquer was applied on top of the base coating layer. 5 g of a barrier coating fluid comprising 5 wt-% SiO₂ as barrier components was sprayed into the UV-curing lacquer layers. 5 g of a photocatalytic coating fluid comprising 5 wt-% nanofluid comprising photocatalytic nanoparticles, wherein the nanofluid is of the
30 type described in patent application WO 2010/110726, and 0.5 wt-% BYK-348 was applied

on the barrier coating. The UV-curing lacquer layers, the barrier coating fluid and the photocatalytic coating fluid were cured at a speed of 10 m/min using a Hg and a Ga lamp at 120 W. After 1 week in UV light the product showed a hydrophilic behaviour with no deterioration of the lacquer.

5 **Wood panel – reference 1**

A coating layer in form of 9 g/m² of a UV-curing lacquer was applied on a surface of a wooden building panel. The UV-curing lacquer was cured at a speed of 10 m/min. Two mercury lamps were used both having a light effect of 120 W.

The product produced was put under UV light and checked for hydrophilicity. After 1 week
10 in UV light the product showed a hydrophobic behaviour.

Wood panel – reference 2

A coating layer in form of 9 g/m² of a UV-curing lacquer was applied on a surface of a wooden building panel. 5 g of a photocatalytic coating fluid comprising 1.5 wt-% nanofluid comprising photocatalytic nanoparticles, wherein the nanofluid is of the type described in
15 patent application WO 2010/110726, and 0.5 wt-% BYK-348 was applied on the UV curing lacquer. The UV-curing lacquer was cured at a speed of 10 m/min. Two mercury lamps were used both having a light effect of 120 W.

The product produced was put under UV light and checked for hydrophilicity. After 1 week
in UV light the product showed a hydrophilic behaviour. The product has started to chalk,
20 since the photocatalytic particles have started to degrade the organic binder of the UV-curing lacquer.

Wood panel – with barrier layer and photocatalytic layer

A coating layer in form of 9 g/m² of a UV-curing lacquer was applied on a surface of a wooden building panel. 5 g of a barrier coating fluid comprising 5 wt-% SiO₂ as barrier
25 components was sprayed into the UV-curing lacquer. 5 g of a photocatalytic coating fluid comprising 1.5 wt-% nanofluid comprising photocatalytic nanoparticles, wherein the nanofluid is of the type described in patent application WO 2010/110726, and 0.5 wt-% BYK-348 was applied on the barrier coating. The UV-curing lacquer, the barrier coating fluid and the photocatalytic coating fluid were cured at a speed of 10 m/min. Two mercury
30 lamps were used at 120 W each.

The product produced was put under UV light. After 1 week in UV light the product showed a hydrophilic behaviour with no deterioration of the lacquer.

CLAIMS:

1. A method for coating a building panel comprising:

applying a first coating fluid comprising an organic binder on a surface of the building panel to obtain at least one coating layer;
- 5 applying a barrier coating fluid comprising a solvent and barrier components, the barrier coating fluid including at least 5 wt % of at least one silicon containing compound, on said at least one coating layer to obtain a barrier layer; and

applying a photocatalytic coating fluid comprising photocatalytic particles on said barrier layer to obtain a photocatalytic layer,
- 10 wherein the organic binder comprises an acrylate or methacrylate monomer, or an acrylate or methacrylate oligomer.
2. A method according to claim 1, wherein the first coating fluid is a radiation curing coating fluid.
3. A method according to claim 1, wherein said acrylate or methacrylate
15 monomer or oligomer is an epoxy (meth)acrylate, an urethane (meth)acrylate, a polyester (meth)acrylate, a polyether (meth)acrylate, an acrylic (meth)acrylate, a silicone (meth)acrylate, a melamine (meth)acrylate, or a combination thereof.
4. A method according to claim 1, wherein the surface of the building
20 panel comprises wood, wood veneer, wood-based board, cork, linoleum, thermoplastic material, thermosetting material, or paper.
5. A method according to claim 1, further comprising partly curing said at least one coating layer, prior to applying the barrier components and the photocatalytic particles.

6. A method according to claim 1, further comprising drying said barrier layer, prior to applying the photocatalytic coating fluid.
7. A method according to claim 1, further comprising drying said photocatalytic layer.
- 5 8. A method according to claim 1, further comprising curing said at least one coating layer.
9. A method according to claim 1, wherein the barrier and/or photocatalytic coating fluid(s) is (are) aqueous fluids.
- 10 10. A method according to claim 1, wherein the barrier and/or photocatalytic coating fluid(s) is (are) applied by spraying.
11. A method according to claim 1, wherein the at least one silicon containing compound is selected from the group consisting of SiO₂, colloidal SiO₂, functional nanoscaled SiO₂, silicone resin, organofunctional silanes, colloidal silicic acid silane and combinations thereof.
- 15 12. A method according to claim 1, wherein the photocatalytic particles are TiO₂.
13. A method for coating a building panel comprising:
- applying a first coating fluid comprising an organic binder on a surface of the building panel to obtain at least one coating layer;
- 20 applying a barrier coating fluid comprising a solvent and barrier components on said at least one coating layer to obtain a liquid barrier layer;
- drying said liquid barrier layer to obtain a barrier layer consisting essentially of at least one silicon containing compound; and

applying a photocatalytic coating fluid comprising the photocatalytic particles on said barrier layer to obtain a photocatalytic layer,

wherein the organic binder comprises an acrylate or methacrylate monomer, or an acrylate or methacrylate oligomer.

- 5 14. A method according to claim 13, wherein the at least one silicon containing compound is selected from the group consisting of SiO₂, colloidal SiO₂, functional nanoscaled SiO₂, silicone resin, organofunctional silanes, colloidal silicic acid silane and combinations thereof.
15. A method according to claim 10, wherein the barrier coating fluid and/or
10 photocatalytic coating fluid is applied with a droplet size of up to about 200 μm.
16. A method according to claim 1, wherein the photocatalytic coating fluid comprises TiO₂ having a size less than 100 nm.
17. A method according to claim 10, wherein the photocatalytic particles
15 comprise up to 30 wt % of the photocatalytic coating fluid and are applied up to 15 ml/m².

1/4

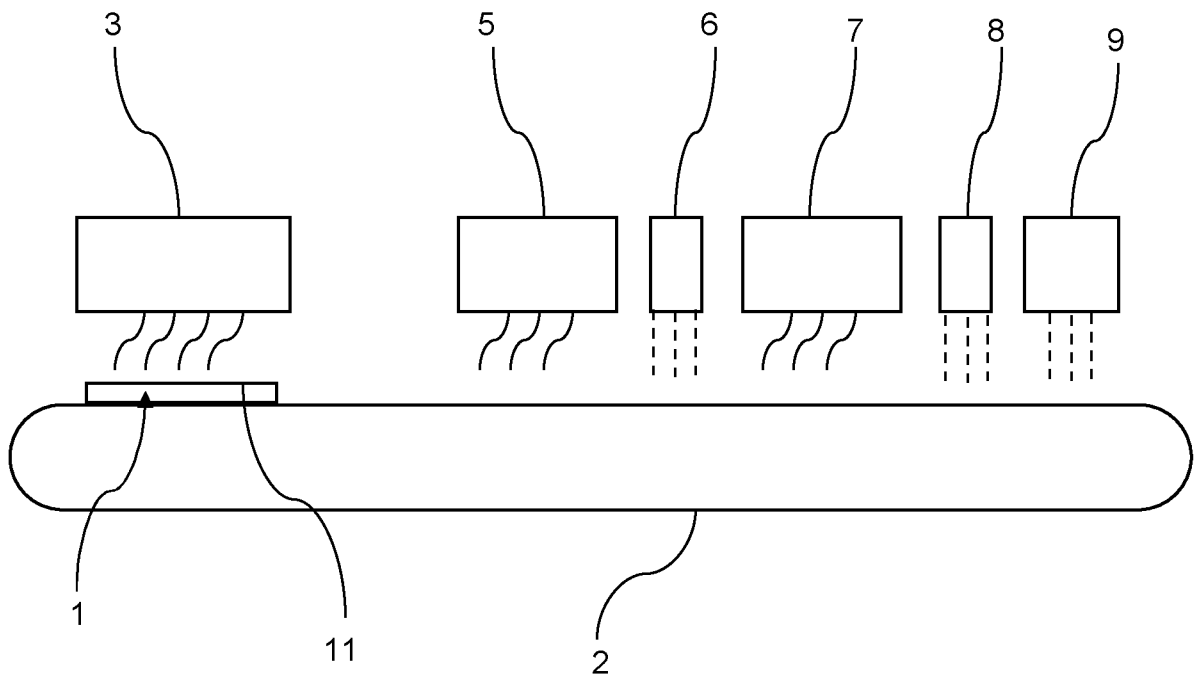

Fig. 1

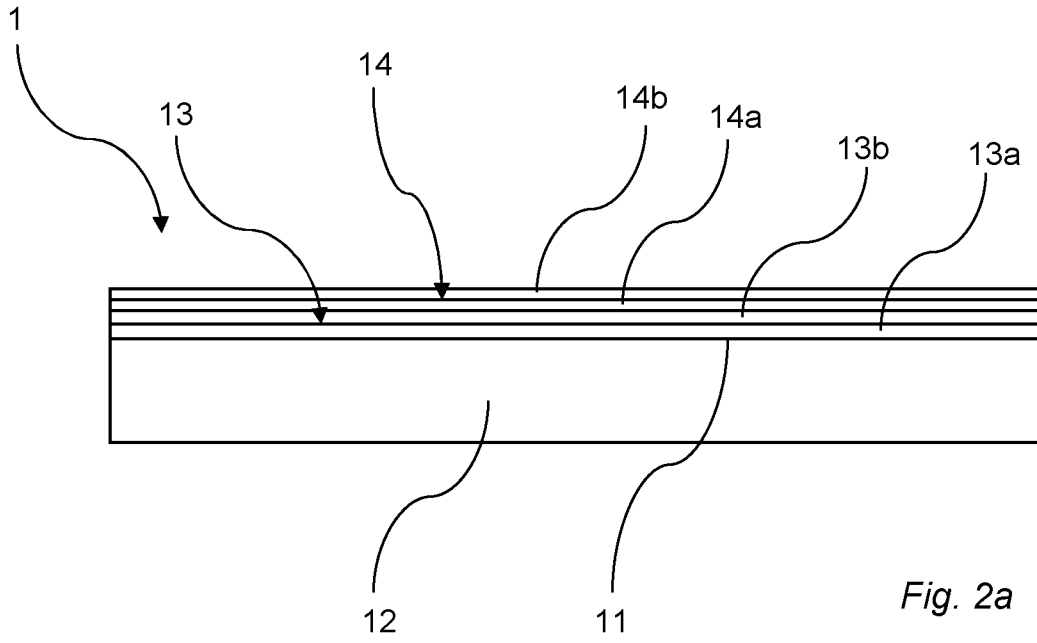

Fig. 2a

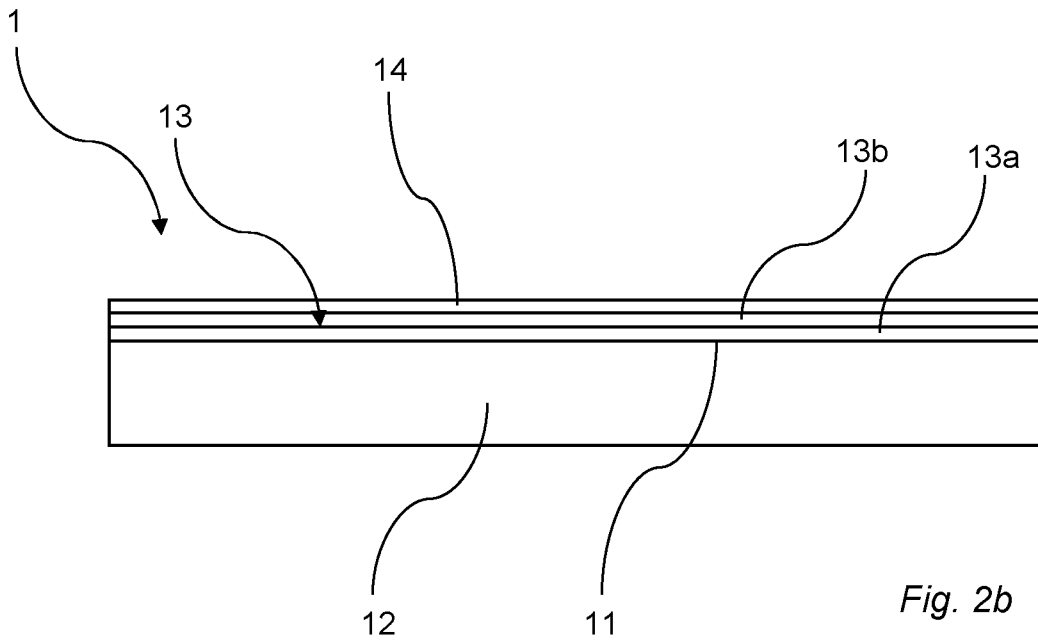

Fig. 2b

3/4

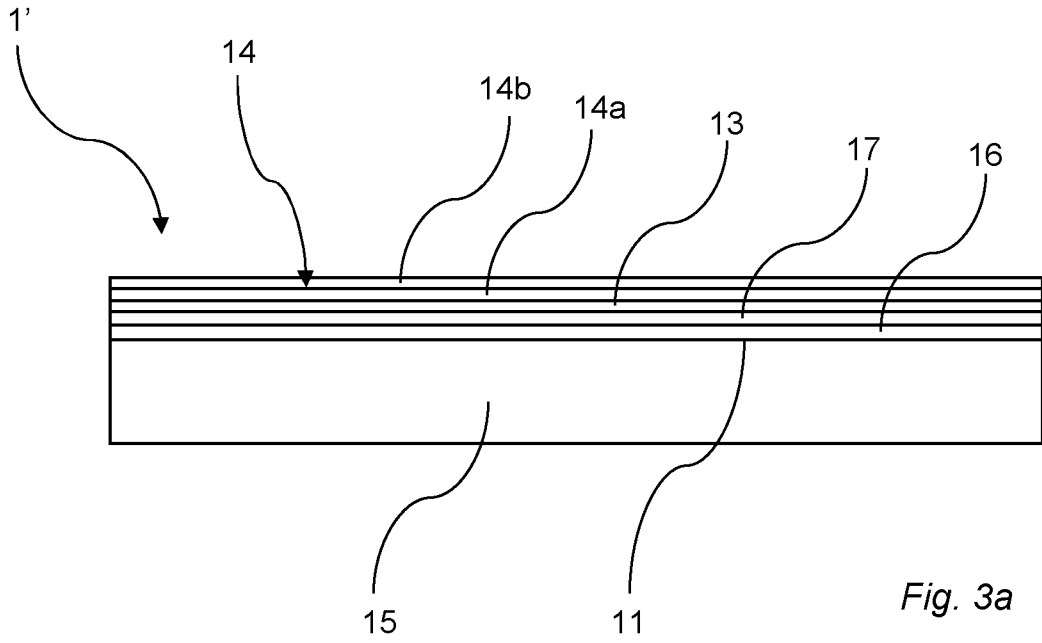

Fig. 3a

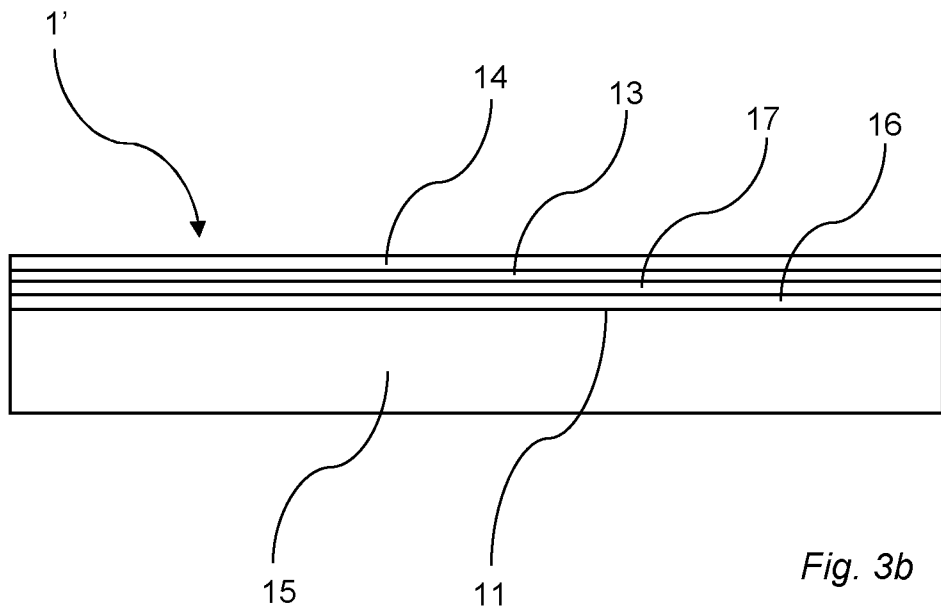

Fig. 3b

4/4

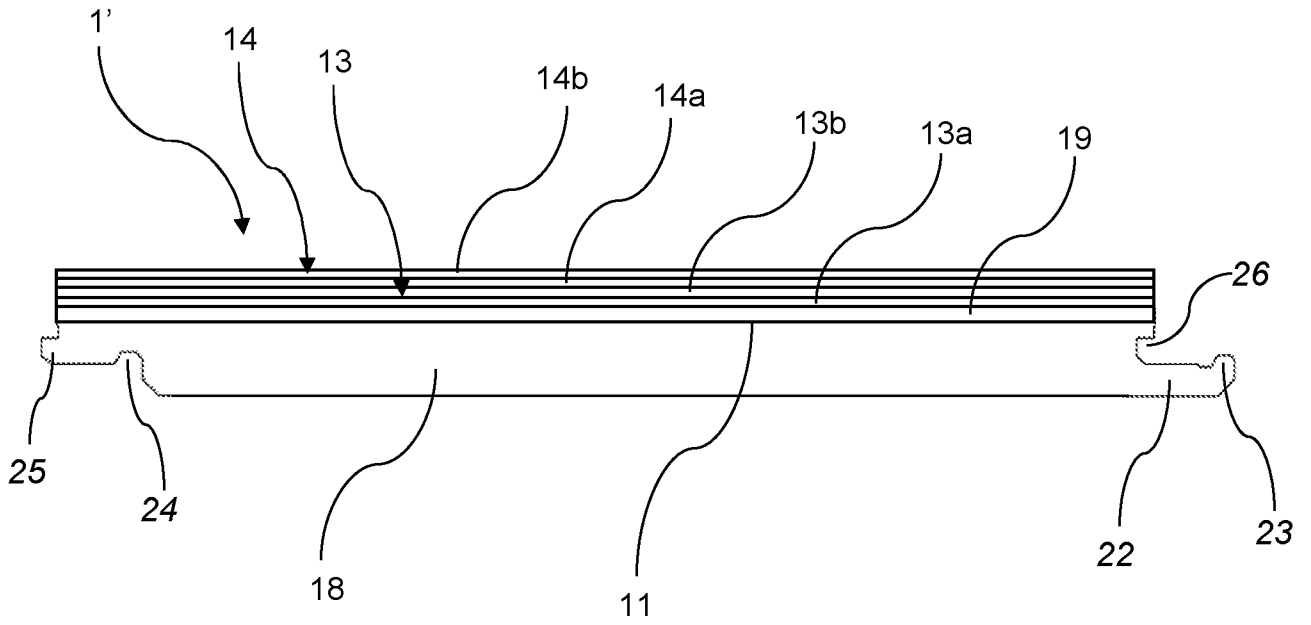

Fig. 4a

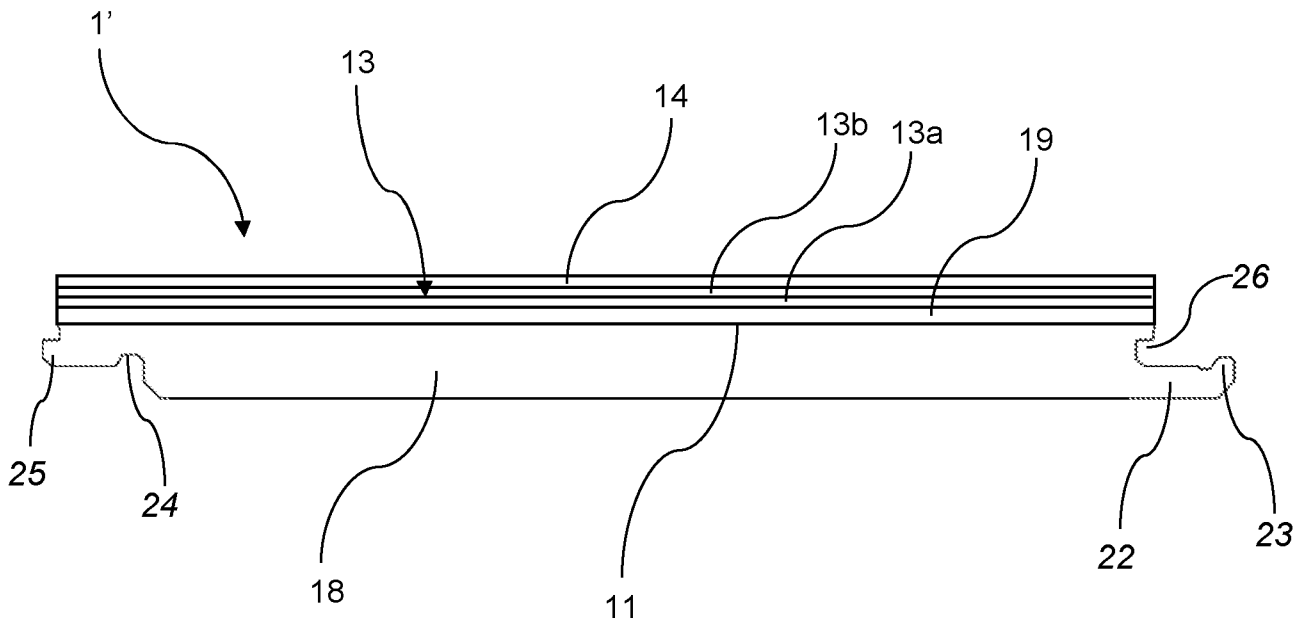

Fig. 4b

