

Aug. 9, 1960

F. A. BROWN

2,948,574

TISSUE DISPENSER FOR AUTOMOBILES

Filed Feb. 8, 1956

3 Sheets-Sheet 1

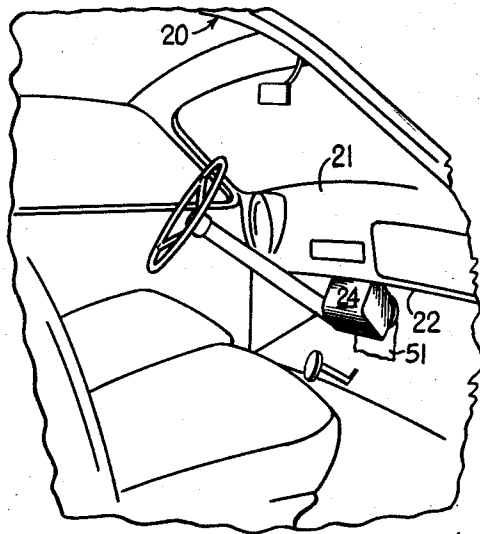

Fig. 1

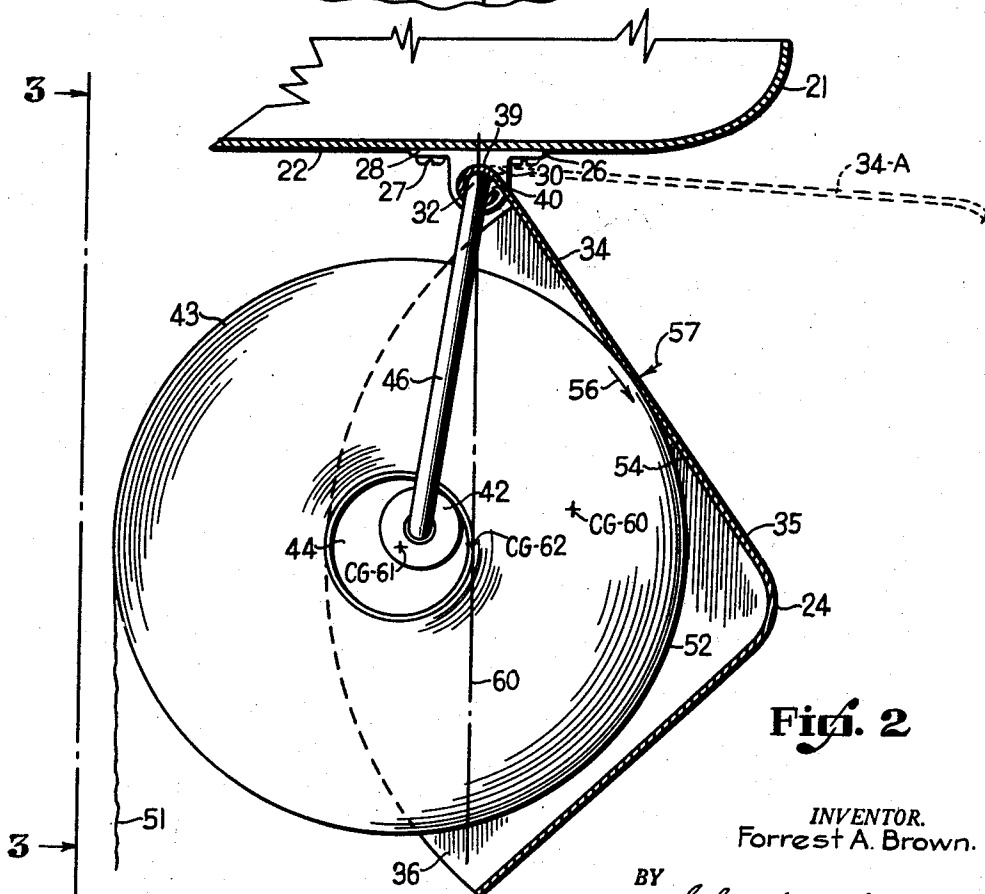

Fig. 2

INVENTOR.
Forrest A. Brown.

BY
Schmieding and Fultz
ATTORNEYS

Aug. 9, 1960

F. A. BROWN

2,948,574

TISSUE DISPENSER FOR AUTOMOBILES

Filed Feb. 8, 1956

3 Sheets-Sheet 2

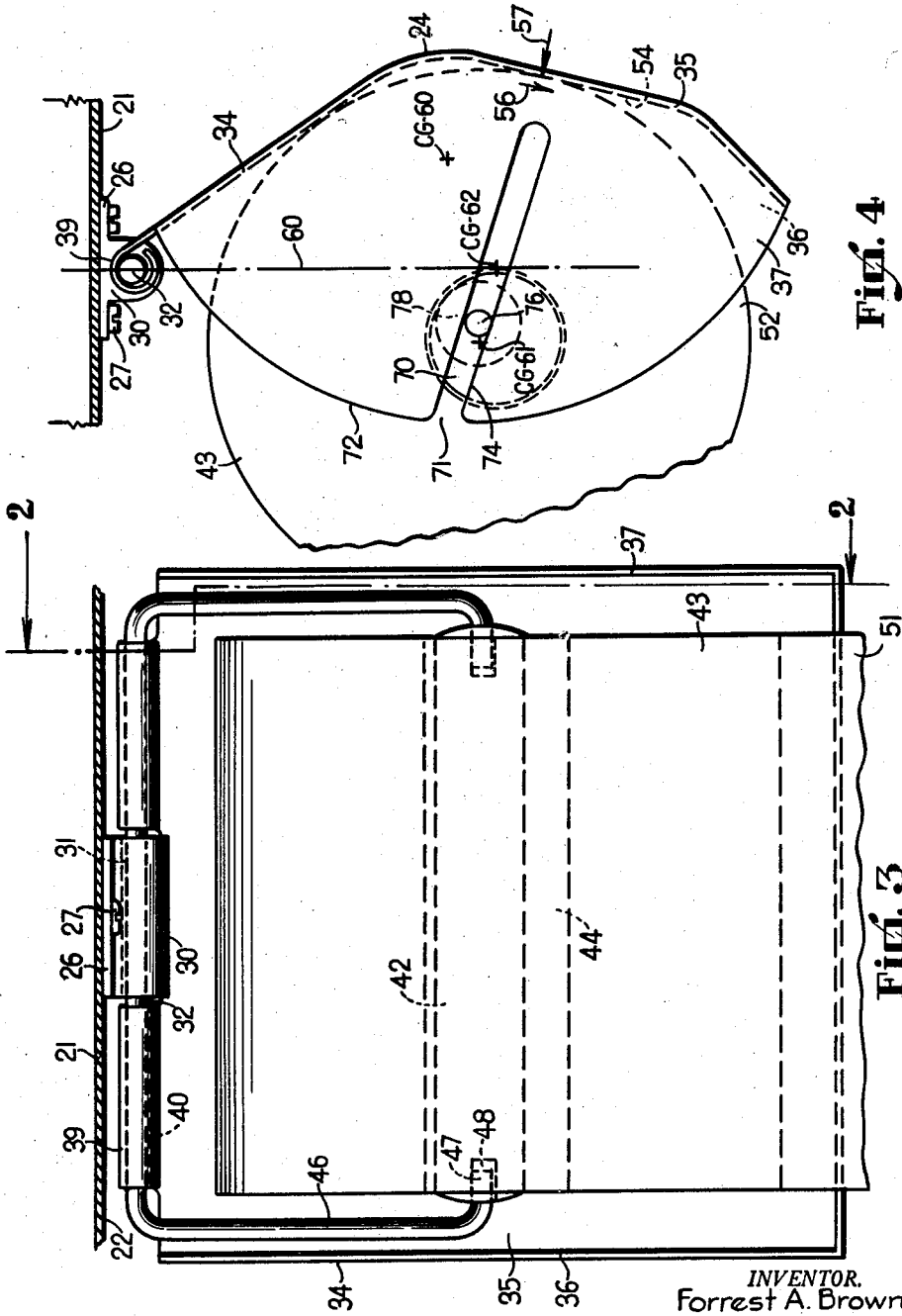

FIG. 4

FIG. 3

INVENTOR.
Forrest A. Brown.

BY *Schmieding and Fultz*
ATTORNEYS

Aug. 9, 1960

F. A. BROWN

2,948,574

TISSUE DISPENSER FOR AUTOMOBILES

Filed Feb. 8, 1956

3 Sheets-Sheet 3

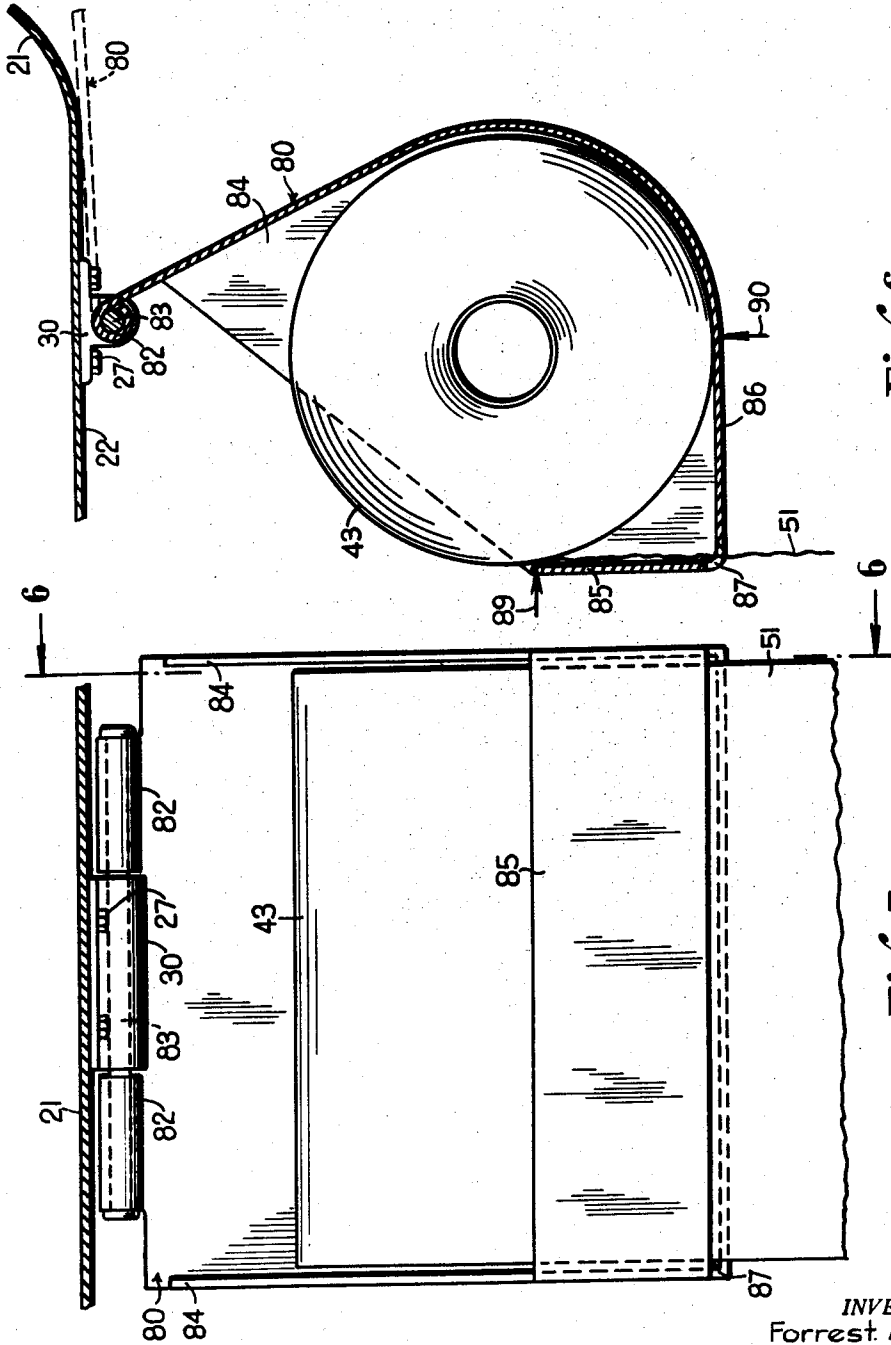

Fig. 6

Fig. 5

INVENTOR.
Forrest A. Brown.

BY
Schmieding and Fultz
ATTORNEYS

1

2,948,574

TISSUE DISPENSER FOR AUTOMOBILES

Forrest A. Brown, 314 N. Court St., Circleville, Ohio

Filed Feb. 8, 1956, Ser. No. 564,152

9 Claims. (Cl. 312-39)

This invention relates to dispensing apparatus for tissue and particularly to novel apparatus of that type which is adapted for use in a motor vehicle.

It is an object of the present invention to provide a tissue dispenser for motor vehicles which will dispense a roll of ordinary toilet tissue and thereby provide a large supply of tissue which can be conveniently replenished at low cost.

It is another object of the present invention to provide a tissue dispenser for motor vehicles which is mounted underneath the dashboard of the vehicle yet which can be quickly and conveniently replenished with a roll of tissue.

It is still another object of the present invention to provide a tissue dispenser for motor vehicles which removably supports a roll of tissue in a novel manner whereby the roll is free to rotate when a length of tissue is being withdrawn, yet which prevents the undesired rotation of the roll and unwinding of the tissue when the dispensing apparatus is subjected to vibrations and bumps encountered by the vehicle.

Further objects and advantages of the present invention will be apparent from the following description, reference being had to the accompanying drawings wherein preferred forms of embodiments of the invention are clearly shown.

In the drawings:

Figure 1 is a partial perspective view of the front compartment of a motor vehicle showing a tissue dispensing apparatus constructed according to the present invention and mounted underneath the dashboard of the vehicle;

Figure 2 is a side sectional view of a tissue dispenser comprising one aspect of the present invention with the section being taken along the line 2-2 of Figure 3;

Figure 3 is a rear elevational view of the tissue dispenser of Figure 2;

Figure 4 is a side elevational view of a tissue dispenser comprising a second aspect of the present invention;

Figure 5 is a rear elevational view of a tissue dispenser comprising a third aspect of the present invention; and

Figure 6 is a side sectional view of the tissue dispenser of Figure 5 with the section being taken along the line 6-6 of Figure 5.

Referring to the drawings, Figure 1 illustrates the interior of the front compartment of a motor vehicle 20 which includes a dashboard 21 having a lower surface 22. A tissue dispenser, indicated generally at 24, is mounted to the under surface 22 of the dashboard in the manner illustrated in Figures 2 and 3.

As seen in Figures 2 and 3, a bracket 26 may be mounted underneath the dashboard 21 by screws 27 which extend through holes 28 in the bracket and screw into the under surface of the dashboard. Bracket includes a block 30 provided with a hole 31 through which is extended a horizontal pivot member 32.

2

The apparatus of Figures 2 and 3 further includes a casing 34 consisting of a front wall portion 35 and side wall portions 36 and 37. The upper edge of the front wall 35 is rolled to provide tubes 39 forming holes 40 through which the pivot member 32 is extended.

As is best seen in Figure 2 the casing 34 can be swung forwardly and upwardly to the configuration illustrated by dotted delineation at 34-A to provide ready access to roll mounting member 42 which is normally disposed between the sidewalls 36 and 37 for rotatably supporting a roll of tissue 43 at the central opening 44 thereof. When casing 34 is swung forwardly and upwardly to the position 34-A the tubes 39 rotate in the openings 31 and 40 which form bearings with the horizontal pivot member 32.

The roll mounting member 42 is suspended from the pivot member 32 by a pair of resilient supports 46 having lower end portions 47 removably inserted into holes 48 in the ends of roll mounting member 42. The roll 43, when exhausted, is replenished by swinging casing 34 forwardly and upwardly and then spreading the resilient supports 46 apart to permit removal of the roll supporting member 42. A new roll of tissue is mounted on member 42 which member is then repositioned between resilient supports 46 with the lower ends 47 inserted into the holes 48.

Referring again to Figure 2, the roll 43 and length of tissue 51 are prevented from unrolling as a result of vibrations of the vehicle due to frictional engagement of the periphery 52 of roll 43 by the inner surface 54 of the front wall 35. Such frictional engagement is diagrammatically represented by the arrow 56 and results from a force, diagrammatically represented at 57, which is exerted by casing 34 due to the lateral displacement of its center of gravity from a vertical datum plane 60 extending through the pivot center of horizontal pivot member 32. The center of gravity of casing 34, alone, is indicated at CG-60 shown in Figure 2 as being displaced laterally from datum 60. The combined center of gravity of the roll 43 and its mounts 42 and 46 is indicated at CG-61 and shown in Figure 2 as being displaced laterally from datum 60 on the other side thereof. The center of gravity of the entire suspended portions of the dispenser is indicated at CG-62 and shown in Figure 2 as coinciding with datum 60.

In view of the above description it will be understood that the casing 34 will always tend to move towards datum 60 and the roll 43 will always tend to move in the opposite direction towards the datum 60 since each suspended unit will tend to occupy a position wherein its center of gravity CG-60 or CG-61 lies vertically below the pivot i.e. the individual centers of gravity will tend to coincide with the datum 60. Hence as the diameter of roll 43 decreases, as a result of dispensing of tissue therefrom, the inner surface 54 of casing 34 will maintain a force 57 on the periphery 52 of the roll which force causes the frictional resistance to rotation indicated diagrammatically at 56.

Reference is next made to Figure 4 which illustrates a tissue dispenser constructed according to the present invention and representing a second aspect thereof. The portions of the apparatus of Figure 4 which correspond to those previously described, in connection with the aspect of Figures 2 and 3, are designated by the same numerals. The aspect of Figure 4 includes a casing 34 provided with a front wall portion 35 and side wall portions 36 and 37. The casing 34 may be suspended from the undersurface 22 of a vehicle dashboard by a bracket 26 which engages a pivot member 32 extended into the tubes 39 rolled into the upper edge of the casing. Hence the casing 34 may be swung forwardly and upwardly,

in the manner previously described, whereby insertion of a new roll of tissue 43 is facilitated.

The side walls 36 and 37 are each provided with a slot 70 having an open end 71 at the rear edge 72 of the side wall. The lower edge 74 of the slot 70 may be inclined to form a shoulder which moveably supports a pin 76 extended from the end of a roll supporting member 78.

With reference to Figure 4, the apparatus is refilled with a roll of tissue by swinging casing 34 forwardly and upwardly. The roll supporting member 78 will then roll out of slot 70. A new roll of tissue is then mounted on member 78 and inserted into casing 34 with sliding the pins 76 into the open ends 74 of the slots 70. The casing 34 is then dropped downwardly and rearwardly to the position illustrated in Figure 4. The periphery 52 of roll 43 then rests against the inner surface 54 of the front wall 35 of casing 34 and such surface exerts a radial force 57 on the periphery 52 of the roll which radial force produces a frictional resistance to rotation of roll 43 which resistance is diagrammatically represented at 56. As the diameter of roll 43 decreases, as a result of the dispensing of tissue therefrom, the member 78 and pins 76 will gravitate downwardly along the inclined shoulder 74 whereby the frictional resistance 56 will be maintained and continue to prevent unwinding of the roll 43 by vibrations of the vehicle, throughout the dispensing of the tissue from the supply.

Reference is next made to Figures 5 and 6 which illustrate still another aspect of the present invention. This apparatus includes a casing indicated generally at 80 which is pivotally suspended from the dashboard 21 by means of the pin 83 which extends through the bracket 30 and tubes 82. The casing 80 may be formed with the tubes 82 integrally formed therewith by rolling the upper edge of the casing into the shape best seen in Figure 5.

For convenience of loading the casing is swung forwardly until the front wall occupies the position shown by the dotted delineation in Figure 6.

Casing 80 further includes sidewalls 84, a bottom wall 86 and a rear wall 85 for retaining the roll 43 in the position illustrated. The bottom of the roll 43 rests on the bottom 86 of the casing with the end 51 of the tissue hanging downwardly through a slot 87 located at the junction of the bottom wall and rear wall of the casing.

Rotation of roll 43 is frictionally resisted by engagement of the outer surface thereof with the inner surface of the casing at the locations represented by the arrows 89 and 90. When the end 51 is pulled downwardly, in removing a length thereof from the roll, the roll 43 will tend to roll rearwardly along the bottom wall 86 and be urged into frictional engagement with the inner surface of rear wall 85. As the diameter of roll 43 decreases with use the point of frictional engagement, represented by arrow 89 in Figure 6, will of course become lower and the point of frictional engagement represented by arrow 90 will move to the left as viewed in Figure 6. It will be understood, however, that no matter how small roll 43 becomes, as a result of using the tissue therefrom, the roll will still roll rearwardly and into frictional engagement with the inner surface of the rear wall when the end 51 of the tissue supply is pulled downwardly. Hence the roll will not unwind excessively when the user pulls excessively hard on the end 51 of the tissue. Moreover, as was the case with the previously described embodiments, frictional engagement of the periphery of the roll by the inner surface of the casing will at all times prevent undesired unwinding of the roll when vibrations of the motor vehicle are encountered.

While the forms of embodiments of the present invention as herein disclosed constitute preferred forms, it is to be understood that other forms might be adopted, all coming within the scope of the claims which follow:

I claim:

1. A tissue dispenser for a motor vehicle having a dash-

board comprising, in combination, a casing means including a front wall portion, side wall portions, and an opening in a rear portion of the casing means; mounting means for pivotally securing said casing means to a portion of said vehicle underneath the said dashboard thereof; a member disposed transversely intermediate said side wall portions, said member serving to extend into the open center of a roll of tissue for rotatably mounting said roll in said casing means; and mounting means for movably supporting said member relative to said casing means, said mounting means including an upwardly extending guide in supporting engagement with said member, said member being arrested against downward movement in said guide by the radial portion of said roll of tissue lying intermediate said member and said casing means, the line of engagement between said member and said guide being horizontally spaced from the center of gravity of said casing means whereby the periphery of said roll is constantly urged into frictional engagement with an inner portion of said casing means by the tendency of said member to move downwardly in said guide and by the tendency for the center of gravity of said casing means to move from a displaced location to a location vertically below the pivotal connection of said casing means to said dashboard.

2. Mechanism defined in claim 1 characterized by said guide being formed by an open ended slot in a side wall portion of said casing, by said member extending into said slot, and by the open end of said slot being located at the edge of said side wall portion adjacent said opening.

3. Mechanism defined in claim 1, characterized by said casing means having its upper end pivotally mounted to said vehicle portion whereby said casing means can be pivoted forwardly and upwardly to provide access to said opening.

4. A tissue dispenser for a motor vehicle having a dashboard comprising, in combination, a casing means including a front wall portion, side wall portions, and an opening in a rear portion of the casing means; a member disposed transversely intermediate said side wall portions, said member serving to extend into the open center of a roll of tissue for rotatably mounting said roll in said casing means; means for mounting said member in said disposed position in said casing means; and means pivotally attaching the upper portion of said casing means to a portion of said vehicle underneath the said dashboard thereof whereby said casing means can be pivoted forwardly and upwardly to provide access to said opening, the center of gravity of said casing means being displaced horizontally relative to a vertical plane through said pivotal attachment by the weight of said roll and said member.

5. Mechanism defined in claim 4 characterized by said means for mounting said member being formed by an open ended slot in a side wall portion of said casing, by said member extending into said slot, and by the open end of said slot being located at the edge of said side wall portion adjacent said opening.

6. Mechanism defined in claim 4 characterized by said means for pivotally supporting said casing means including a horizontally disposed pivot member, a bracket attached to said vehicle portion and provided with an opening into which said horizontally disposed pivot member is extended, and the upper portion of said casing means including an opening through which said horizontally disposed pivot member is extended, certain of said openings forming bearing means for the pivotal support of said casing means.

7. Mechanism defined in claim 4 characterized by said means for pivotally supporting said casing means including a horizontally disposed pivot member, a bracket attached to said vehicle portion and provided with an opening into which said horizontally disposed pivot mem-

5

ber is extended, the upper portion of said casing means including an opening through which said horizontally disposed pivot member is extended, certain of said openings forming bearing means for the pivotal support of said casing means and said means for mounting said member being provided by vertically extending support means having an upper end extended into said bearing means and a lower end attached to said member.

8. A tissue dispenser for a motor vehicle having a dashboard comprising, in combination, a casing means including a front wall portion, side wall portions, and an opening in a rear portion of the casing means; a member disposed transversely intermediate said side wall portions, said member serving to extend into the open center of a roll of tissue for rotatably mounting said roll in said casing means; mounting means for pivotally attaching said member to a portion of said vehicle underneath the said dashboard thereof; means for pivotally suspending said casing means from said portion of said vehicle, said means including a horizontally disposed pivot member, a bracket attached to said vehicle portion and provided with an opening into which said horizontally disposed pivot member is extended, and the upper portion of said casing means including an opening through which said horizontally disposed pivot member is extended, certain of said openings forming bearing means for the pivotal support of said casing means, the center of gravity of said casing portion being laterally displaced from a vertical plane passing through said pivot by a radial portion of said roll lying intermediate said member and an inner portion of said casing, the periphery of said roll being in engagement with said front wall at a single line of contact, the balance of said periphery being clear of said casing means.

9. A tissue dispenser for a motor vehicle having a

6

dashboard comprising, in combination, a casing means including a front wall portion, side wall portions, and an opening in a rear portion of the casing means; a member disposed transversely intermediate said side wall portions, said member serving to extend into the open center of a roll of tissue for rotatably mounting said roll in said casing means; mounting means for pivotally attaching said member to a portion of said vehicle underneath the said dashboard thereof; means for pivotally suspending said casing means from said portion of said vehicle, said means including a horizontally disposed pivot member, a bracket attached to said vehicle portion and provided with an opening into which said horizontally disposed pivot member is extended, and said means for attaching said first mentioned member being provided by vertically extending support means having an upper end extended into said bearing means and a lower end attached to said first mentioned member, the center of gravity of said casing portion being laterally displaced from a vertical plane passing through said pivot by a radial portion of said roll lying intermediate said member and an inner portion of said casing, the periphery of said roll being in engagement with said front wall at a single line of contact, the balance of said periphery being clear of said casing means.

References Cited in the file of this patent

UNITED STATES PATENTS

1,436,990	Lillibridge	Nov. 28, 1922
1,713,857	Rapp	May 21, 1929
2,008,297	Van Berkel	July 16, 1935
2,657,873	Dittman et al.	Nov. 3, 1953

FOREIGN PATENTS

373,319	Italy	July 24, 1939
---------	-------	---------------