

J. HIEBEL.
PICKER DEVICE FOR LOOMS.

(Application filed Oct. 10, 1900.)

(No Model.)

2 Sheets—Sheet 1.

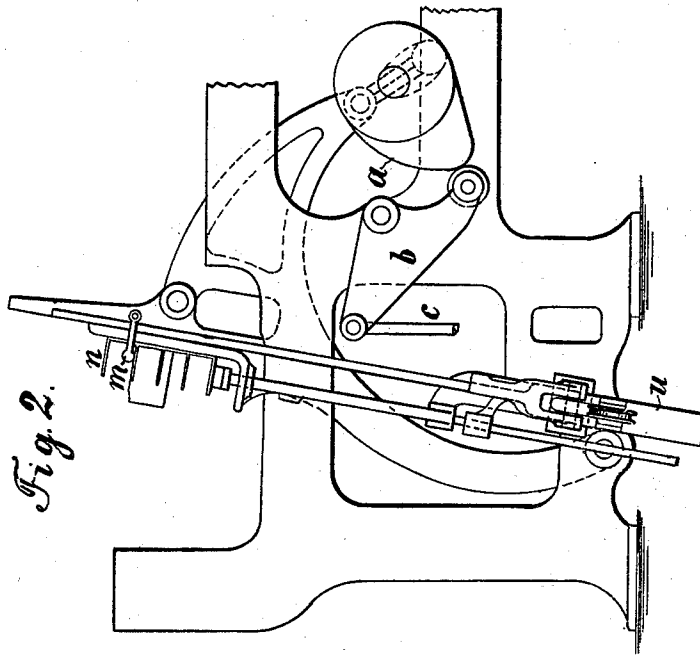

Fig. 2.

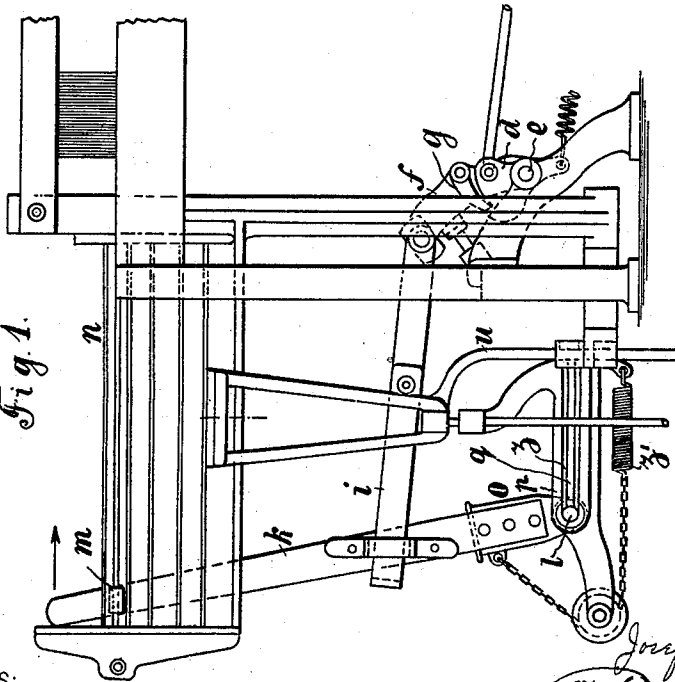

Fig. 1.

WITNESSES:
Ella L. Gies
Otto ...

INVENTOR
J. Hiebel
 BY
Richardson
 ATTORNEYS

J. HIEBEL.
PICKER DEVICE FOR LOOMS.

(Application filed Oct. 10, 1900.)

(No Model.)

2 Sheets—Sheet 2.

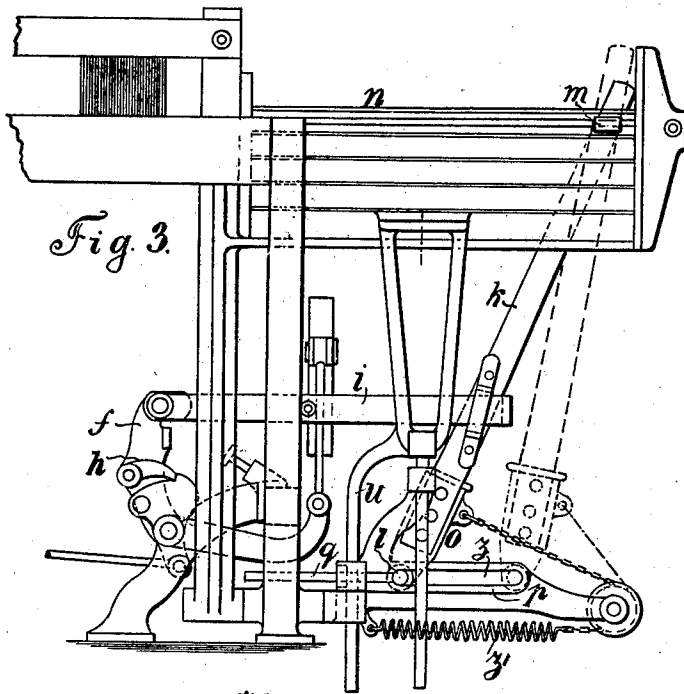

Fig. 3.

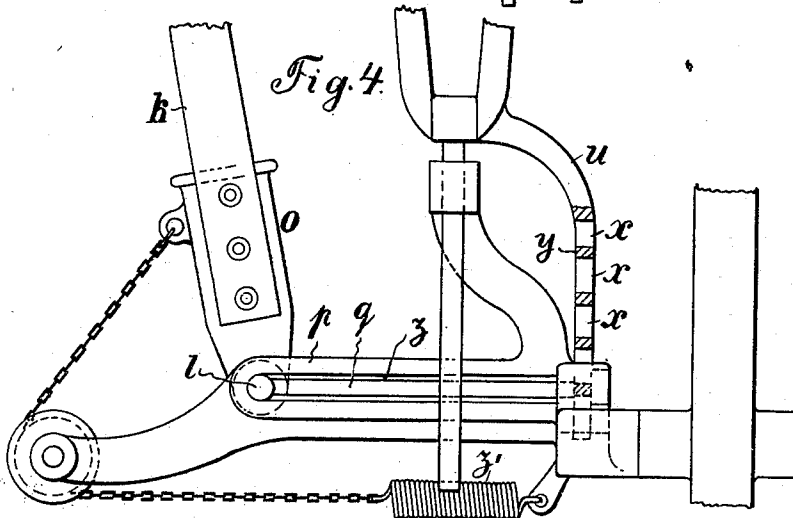

Fig. 4.

Fig. 5.

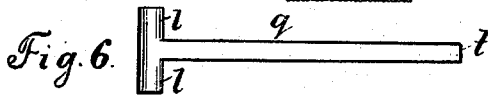
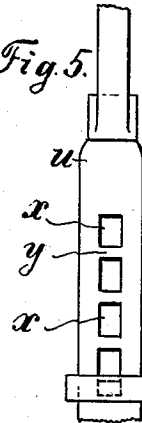

Fig. 6.

WITNESSES:
Ellas L. Giles
Otto ...

INVENTOR
Josef Hiebel
 BY
Richard ...
 ATTORNEYS

UNITED STATES PATENT OFFICE.

JOSEF HIEBEL, OF AIX-LA-CHAPELLE, GERMANY.

PICKER DEVICE FOR LOOMS.

SPECIFICATION forming part of Letters Patent No. 665,904, dated January 15, 1901.

Application filed October 10, 1900. Serial No. 32,585. (No model.)

To all whom it may concern:

Be it known that I, JOSEF HIEBEL, a subject of the Emperor of Austria-Hungary, residing at Aix-la-Chapelle, Germany, have invented certain new and useful Improvements in Picker Devices for Mechanical Looms, of which the following is a specification.

My invention relates to a picker or shot device for mechanical looms, its object being to prevent a break in the beat-up when the lathe is in the wrong position.

In the accompanying drawings a device of this kind is represented in Figure 1 for the left side, and in Fig. 3 for the right side, of the loom in two different positions. Fig. 2 is a side view of the device; Fig. 4, a view of the lower part of the device on a larger scale. Fig. 5 is a side view of the stop-slide for the picker-stick. Fig. 6 is a top view of the bolt connected with the pivot of the picker-stick.

The movement of the batten is effected by the eccentric *a*, Figs. 1, 2, and 3, which moves at every revolution the angle-levers *b*, and by the connecting-rod *c* the batten-sector *d*.

On the batten-shafts *e* are situated loosely the batten-levers *f*, which are carried along by the sectors or drivers *d* in the manner as may be required by means of the clicks or bolts *g* and *h*. The batten-levers *f* are connected by drawing-bands *i* with the picker-sticks *k*. The picker-stick has its pivot on a bolt *q*, Fig. 6, provided with two pins, said bolt being journaled in the slot *z*, Figs. 1 and 3.

When the picker-stick *k* is moved by means of the band *i*, it revolves around the point *l* and gives the picker or driver the required motion for the shot or pick in the direction of the arrow. The picker-stick *k*, Fig. 4, is fixed in the picker-shoe *o*, which catches over the guiding-arm *p* and revolves around the lateral pins *l* of a bolt *q*. This bolt is journaled horizontally in a slot *z* of the guiding-arm *p* and presses by its rear extremity *t* on the slide *v*, Figs. 4 and 5, which is connected with the shuttle-box, so that it is raised and lowered with the same. When the picker-stick *k* is moved by the band *i* in the direction of the arrow for the purpose of throwing the shuttle out of the shuttle-box, the bolt *q*, Figs. 1, 4, and 6, presses against the slide *v*, and by means of the latter said bolt is pre-

vented from displacement when the shuttle-box is in correct position.

The slide in Figs. 4 and 5 is provided with openings *x* and cross-pieces or stays *y*. The distance from one stay center to the other corresponds exactly to the height of the box from leash to leash. When the shuttle-box *n* is at its proper position—that is, when the one shuttle-box bottom is precisely at the height of the run or way of the lathe—one of the cross-pieces or stays *y* will place itself in front of the bolt *q* in such a manner, according to the position of the shuttle-box, that a displacement or shifting of the arm is prevented, because its extremity *t* will strike on a stay or bridge *y*.

When the shuttle-box for any reason whatever has not reached its correct position at the backing of the shuttle, the picker or driver *m* cannot execute its movement in the arrow direction. As a consequence, to avoid breaking, the pivot *l* of the picker-stick must be capable of displacement in the slot *z* of the guiding-arm *p*. There is nothing to prevent this displacement in this case, as with the incorrect position of the box the bolt *q* is not located opposite one of the bridges or stays *y*, but opposite one of the openings *x*, so that, as shown in Fig. 3, the bolt can pass through these openings, whereby breaking of the beat-up is prevented.

The spring *z'*, Figs. 1, 3, and 4, pulls back the picker-stick *k* as soon as the batten-levers *f* go back.

Having now described my invention, what I claim as new, and desire to secure by Letters Patent, is—

1. The combination with the shuttle-boxes of a loom and the picker-stick, of a sliding fulcrum for the picker-stick, and means controlled by the position of the boxes for holding said fulcrum against sliding when the box is in proper position.

2. The combination with the shuttle-boxes of a loom and the picker-stick, of a sliding rod or bolt suitably guided and pivotally connected with said picker-stick and forming the fulcrum therefor, and means controlled by the position of the boxes for holding said rod against movement when the box is in proper position.

3. The combination with the shuttle-boxes
of a loom and the picker-sticks, of a sliding
bolt suitably guided and having a T-shaped
head, a shoe at the lower end of said stick
5 pivotally engaging said T-shaped head, and
means controlled by the position of the boxes
for holding said bolt against movement when
the box is in proper position.

4. The combination with the shuttle-boxes
10 of a loom, and the picker-sticks, of a sliding
bolt suitably guided and having a pivoted con-

nection with the picker-stick at one end, and
a slide moved by the movement of the boxes
transversely across the end of the bolt, said
slides having alternate abutments and spaces 15
cooperating with the end of the bolt.

In witness whereof I have hereunto set my
hand in presence of two witnesses.

JOSEF HIEBEL.

Witnesses:

EUGEN MILLER,
AUGUST BEBEL.