



(43) International Publication Date
17 September 2015 (17.09.2015)

- (51) International Patent Classification:
G02B 6/125 (2006.01) *G02B 6/32* (2006.01)
- (21) International Application Number:
PCT/US2015/020711
- (22) International Filing Date:
16 March 2015 (16.03.2015)
- (25) Filing Language: English
- (26) Publication Language: English
- (30) Priority Data:
61/953,137 14 March 2014 (14.03.2014) US
- (72) Inventor; and
(71) Applicant : **ZHENG, Wenxin** [US/US]; 108 Baltic Court, Moore, South Carolina 29369 (US).
- (74) Agents: **PELLEGRINI, Carl J.** et al.; Sughrue Mion, PLLC, 2100 Pennsylvania Avenue, Suite 800, Washington, District of Columbia 20037-3213 (US).
- (81) Designated States (*unless otherwise indicated, for every kind of national protection available*): AE, AG, AL, AM,

AO, AT, AU, AZ, BA, BB, BG, BH, BN, BR, BW, BY, BZ, CA, CH, CL, CN, CO, CR, CU, CZ, DE, DK, DM, DO, DZ, EC, EE, EG, ES, FI, GB, GD, GE, GH, GM, GT, HN, HR, HU, ID, IL, IN, IR, IS, JP, KE, KG, KN, KP, KR, KZ, LA, LC, LK, LR, LS, LU, LY, MA, MD, ME, MG, MK, MN, MW, MX, MY, MZ, NA, NG, NI, NO, NZ, OM, PA, PE, PG, PH, PL, PT, QA, RO, RS, RU, RW, SA, SC, SD, SE, SG, SK, SL, SM, ST, SV, SY, TH, TJ, TM, TN, TR, TT, TZ, UA, UG, US, UZ, VC, VN, ZA, ZM, ZW.

- (84) Designated States (*unless otherwise indicated, for every kind of regional protection available*): ARIPO (BW, GH, GM, KE, LR, LS, MW, MZ, NA, RW, SD, SL, ST, SZ, TZ, UG, ZM, ZW), Eurasian (AM, AZ, BY, KG, KZ, RU, TJ, TM), European (AL, AT, BE, BG, CH, CY, CZ, DE, DK, EE, ES, FI, FR, GB, GR, HR, HU, IE, IS, IT, LT, LU, LV, MC, MK, MT, NL, NO, PL, PT, RO, RS, SE, SI, SK, SM, TR), OAPI (BF, BJ, CF, CG, CI, CM, GA, GN, GQ, GW, KM, ML, MR, NE, SN, TD, TG).

Published:

— with international search report (Art. 21(3))

(54) Title: METHOD FOR MAKING BENT TIP FIBERS

Figure 1D

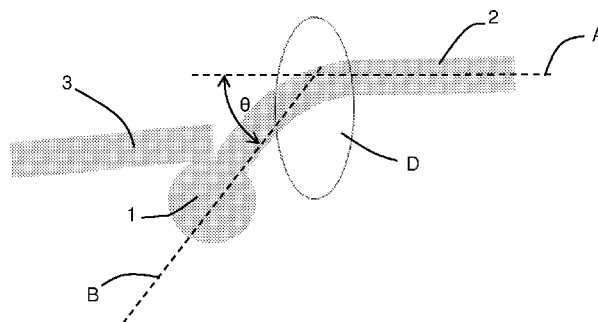

(57) Abstract: A method of making a bent tip fiber ball lens by moving a bender to a first side of a ball lens at an end of an optical fiber that has a first axis; moving the bender in a first direction such that the bender applies a force to the ball lens, wherein the ball lens and optical fiber is bent such that a first angle between the first axis and a second axis, which extends from an end of the ball lens and the end of the optical fiber is greater than zero; applying heat, for a first time, to the optical fiber at a location that is a first distance from the ball lens; removing the heat and allowing the optical fiber to harden such that the first angle is maintained after the bender force is removed.

WO 2015/139024 A1

METHOD FOR MAKING BENT TIP FIBERS

CROSS-REFERENCE TO RELATED APPLICATIONS

[01] This application is based upon and claims the benefit of priority from United States Provisional Application No. 61/953,137, filed March 14, 2014 in the United States Patent and Trademark Office, the disclosures of which are incorporated herein in its entirety by reference.

BACKGROUND**1. Field**

[02] The invention is related to a method for making a bent tip fiber ball lens.

2. Related Art

[03] The background information provided herein is for the purpose of generally presenting the context of the disclosure. Work of the presently named inventor, to the extent it is described in this background section, as well as aspects of the description that may not otherwise qualify as prior art at the time of filing, are neither expressly nor impliedly admitted as prior art against the present disclosure.

[04] Ball lenses may be used with optical fibers to aid in focusing light emanating from an optical fiber, coupling light between adjacent optical fibers. As such, ball lenses are used for a variety of purposes in optical probes for biomedical applications. However, in some applications it is advantageous to have the ball lens that is bent at the end. For example, in some applications, there is a bundle of fibers with at least one fiber connected to a laser and at least one connected to a camera. The camera fiber can then be used to observe the operation of the laser. However, if the end of the camera fiber is too close to the end of the laser, the camera fiber can be damaged (melted) by the laser. Thus, a bent tip fiber is used to create a separation form the end of the camera fiber and the end of the laser.

[05] For many of these medical applications, the ball lens fiber is designed for a one time use, due to the strong laser beam that will evaporate both the target and the fiber end. Therefore, there is a need for large quantities of bent ball lens. The requirement of production, automation, and repeatability is a major concern. The current manually heat and bend method relies too much on the experience of operators. Therefore, an automated programmable process using existing fully automated fusion splicers is a desired solution.

SUMMARY

[06] Exemplary implementations of the present invention address at least the above problems and/or disadvantages and other disadvantages not described above. Also, the present invention is not required to overcome the disadvantages described above, and an exemplary implementation of the present invention may not overcome any of the problems listed above.

[07] According to an aspect of an exemplary embodiment, a method of making a bent tip fiber ball lens includes: moving a bender to a first side of a ball lens at an end of an optical fiber that has a first axis; moving the bender in a first direction such that the bender applies a force to the ball lens, wherein the ball lens and optical fiber is bent such that a first angle between the first axis and a second axis, which extends outward from an end of the ball lens and an end of the optical fiber is greater than zero; applying heat, for a first time, to said optical fiber at a location that is a first distance from said ball lens; removing the heat and allowing the optical fiber to harden such that the first angle is maintained after the bender force is removed.

[08] Other features of the exemplary embodiment include the bender being moved by a fusion splicer and the heat being applied by the fusion splicer.

[09] Other features of the exemplary embodiment include the first time being in a range between approximately 0.2 and 10 seconds.

[10] Other features of the exemplary embodiment include the heat being applied by power in a range between 12 and 18 milliamps.

[11] Other features of the exemplary embodiment include the first angle being in a range between approximately 30 and 90 degrees.

[12] Other features of the exemplary embodiment include the bender being an optical fiber.

BRIEF DESCRIPTION OF THE DRAWING

[13] Figure 1 illustrates an embodiment of a method for making a bent tip fiber ball lens.

[14] Figure 2 illustrates an embodiment of a fusion splicer that can be used to perform a method for making a bent tip fiber ball lens.

[15] Figure 3 shows examples of different types of fiber ball lenses.

[16] Figure 4 shows two photographs of an exemplary bent tip fiber made with an embodiment of the invention.

DETAILED DESCRIPTION

[17] The following detailed description is provided to assist the reader in gaining a comprehensive understanding of the apparatuses described herein. Various changes, modifications, and equivalents of the apparatuses described herein will suggest themselves to those of ordinary skill in the art. Descriptions of well-known functions and structures are omitted to enhance clarity and conciseness.

[18] The terms used in the description are intended to describe embodiments only, and shall by no means be restrictive. Unless clearly used otherwise, expressions in a singular form include a meaning of a plural form. In the present description, an expression such as “comprising” or “including” is intended to designate a characteristic, a number, a step, an operation, an element, a part or combinations thereof, and shall not be construed to preclude any presence or possibility of one or more other characteristics, numbers, steps, operations, elements, parts or combinations thereof.

[19] Referring to the drawings, Figures 1A to 1D illustrate an embodiment of a method for making a bent tip fiber ball lens.

[20] Figure 1A shows a fiber ball lens 1 at the end of an optical fiber 2. In one embodiment, an exemplary optical fiber is a 125 micron single mode fiber. However, the method is not limited to 125 micron fibers. Figure 1A also shows a first axis A that runs lengthwise through the center of optical fiber 2.

[21] Figure 1B shows a bender 3 that has been moved next to a first side of the ball lens 1 at the end of the optical fiber 2. In this embodiment, the bender 3 is a 125 micron single mode fiber. However, the bender 3 may be any other suitable material that can apply enough force to bend the ball lens 1 to a desired angle.

[22] Figures 1C and 1D show the bender 3 being moved in a first direction C such that the bender applies a force to the ball lens 1. The force causes the ball lens 1 and the end of the optical fiber 2 to be bent such that a first angle θ between the first axis A and a second axis B, which extends outward from the end of end of the optical fiber 2 and ball lens 1, is greater than zero. While any bent angle can be created, a preferred range of the first angle is between 30 and 90 degrees.

[23] Next, heat is applied, for a first time, to the optical fiber 2 at a location D that is a first distance from the ball lens 1. A preferred first distance from the ball lens is approximately 0.5 mm to 25 mm. A preferred time for applying the heat is between approximately 0.2 and 10 seconds. A preferred heat may be generated by arc power that is generated by approximately 12-18 milliamps. The heat should be powerful enough and applied for enough time to slightly soften the optical fiber 2 without causing any significant degradation to the optical properties of the ball lens 1 or fiber 2.

[24] Next, the heat is removed to allow the optical fiber 2 to harden such that the first angle θ is maintained between the first axis A and the second axis B after the bender 3 force is removed. A preferred time for the harden to take place is approximately 0.01 to 0.1 second.

[25] Figure 2 illustrates an embodiment of a conventional fusion splicer 10 that can be used to perform a method for making a bent tip fiber ball lens. The major elements of the fusion splicer 10 pertinent to the method are a controller 11, fiber holders 12, 13 and heat source 14. The controller 11 controls the operation of the fiber holders 12, 13 and heat source 14. The fiber holders 12, 13 are configured to hold the bender 3 and optical fiber 2, for example, by use of a V-groove clamp. However, other known holding configurations may be used. The fiber holders 12, 13 are also configured to move in the X, Y and Z directions, similar to the movements that are necessary to perform fusion splicing. This movement can be used to move the bender 3 to apply a bending force to the ball lens 1. The heat source 14 may be generated by arc power. In an exemplary embodiment, the heat source 14 is generated by approximately 14-15 milliamps and is applied to area D, a first distance from the ball lens as shown in Figure 1D. One example of a conventional fusion splicer that can perform the method is the Fujikura LZM-100 LAZERMaster.

[26] Figure 3 shows examples of different types of fiber ball lenses that can be used in the exemplary method.

[27] Figure 4 shows two photographs of an exemplary bent tip fiber made with an embodiment of the invention. The bent angle is approximately 30 degrees. The top photograph is a side view and the bottom photograph is a top view.

[28] As mentioned above, the embodiments described above are merely exemplary and the general inventive concept should not be limited thereto. While this specification contains many features, the features should not be construed as limitations on the scope of the disclosure or the appended claims. Certain features described in the context of separate embodiments can also be implemented in combination. Conversely, various features described in the context of a single embodiment can also be implemented in multiple embodiments separately or in any suitable sub-combination.

LISTING OF CLAIMS

What is claimed is:

1. A method of making a bent tip fiber ball lens comprising:
moving a bender to a first side of a ball lens at an end of an optical fiber that has a first axis;
moving said bender in a first direction such that said bender applies a force to said ball lens, wherein said ball lens and optical fiber is bent such that a first angle between said first axis and a second axis, which extends outward from an end of said ball lens and an end of said optical fiber is greater than zero;
applying heat, for a first time, to said optical fiber at a location that is a first distance from said ball lens;
removing said heat and allowing said optical fiber to harden such that said first angle is maintained after said bender force is removed.
2. The method according to claim 1, wherein said bender is moved by a fusion splicer and said heat is applied by said fusion splicer.
3. The method according to claim 1, wherein said first time is in a range between approximately 0.2 and 10 seconds.
4. The method according to claim 1, wherein said heat is applied by power in a range between 12 and 18 milliamps.

5. The method according to claim 2, wherein said first time is in a range between approximately 0.2 and 10 seconds.

6. The method according to claim 2, wherein said heat is applied by power in a range between 12 and 18 milliamps.

7. The method according to claim 3, wherein said heat is applied by power in a range between 12 and 18 milliamps.

8. The method according to claim 1, wherein said first angle is in a range between approximately 30 and 90 degrees.

9. The method according to claim 2, wherein said first angle is in a range between approximately 30 and 90 degrees.

10. The method according to claim 3, wherein said first angle is in a range between approximately 30 and 90 degrees.

11. The method according to claim 4, wherein said first angle is in a range between approximately 30 and 90 degrees.

12. The method according to claim 7, wherein said first angle is in a range between approximately 30 and 90 degrees.

13. The method according to claim 5, wherein said first angle is in a range between approximately 30 and 90 degrees.
14. The method according to claim 6, wherein said first time is in a range between approximately 0.2 and 10 seconds.
15. The method according to claim 14, wherein said first angle is in a range between approximately 30 and 90 degrees.
16. The method according to claim 1, wherein said bender is an optical fiber.
17. The method according to claim 15, wherein said bender is an optical fiber.
18. The method according to claim 12, wherein said bender is an optical fiber.
19. The method according to claim 11, wherein said bender is an optical fiber.
20. The method according to claim 8, wherein said bender is an optical fiber.

Figure 1A

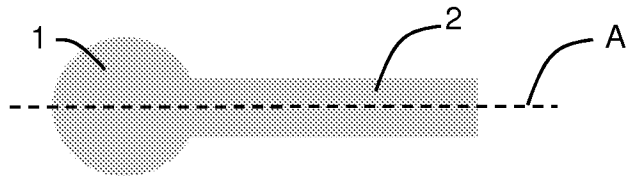

Figure 1B

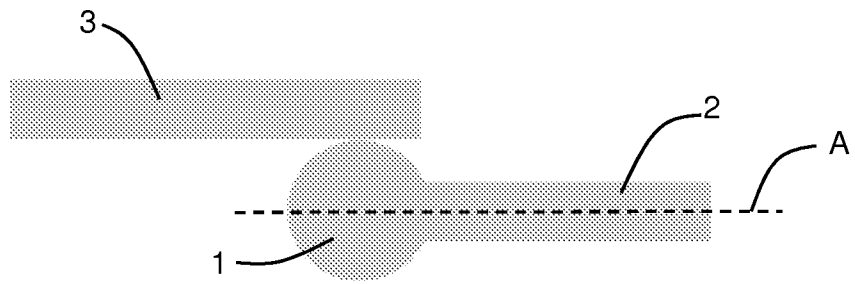

Figure 1C

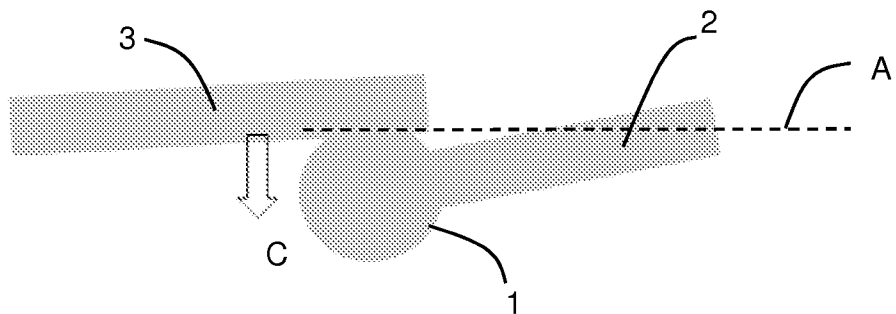

Figure 1D

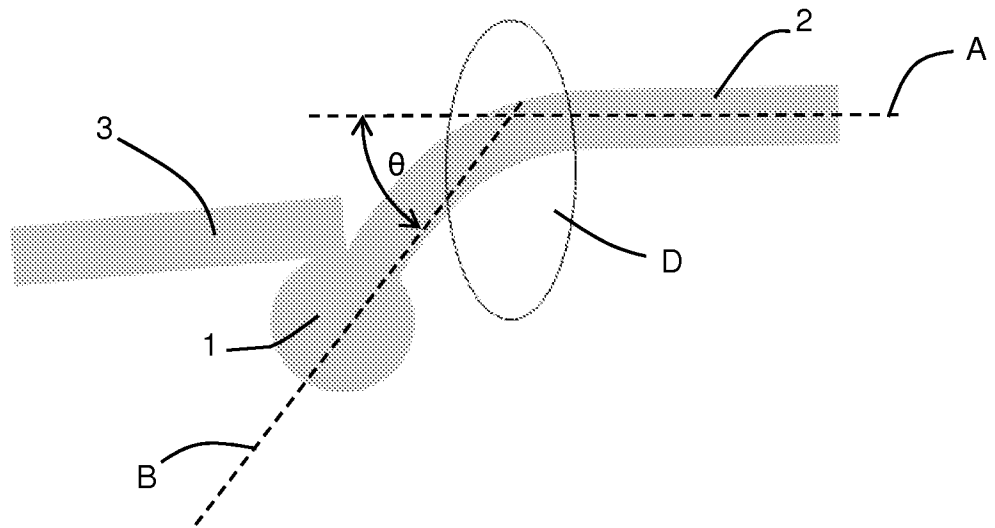

Figure 2

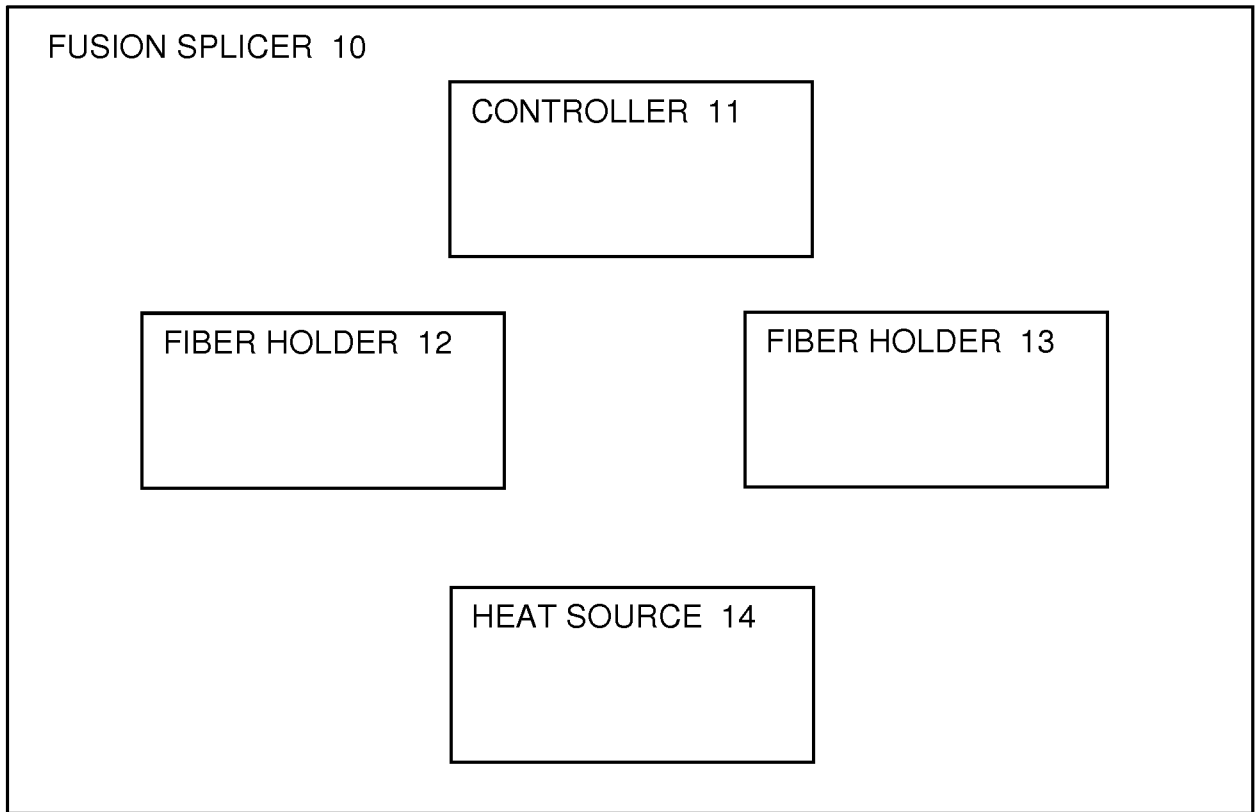

Figure 3

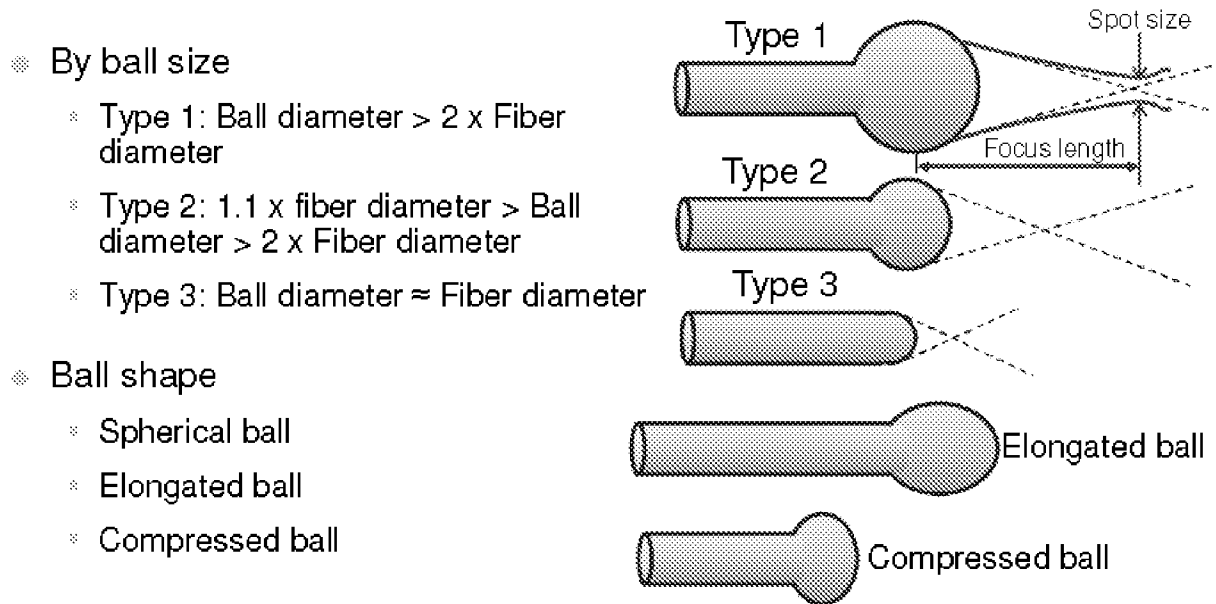
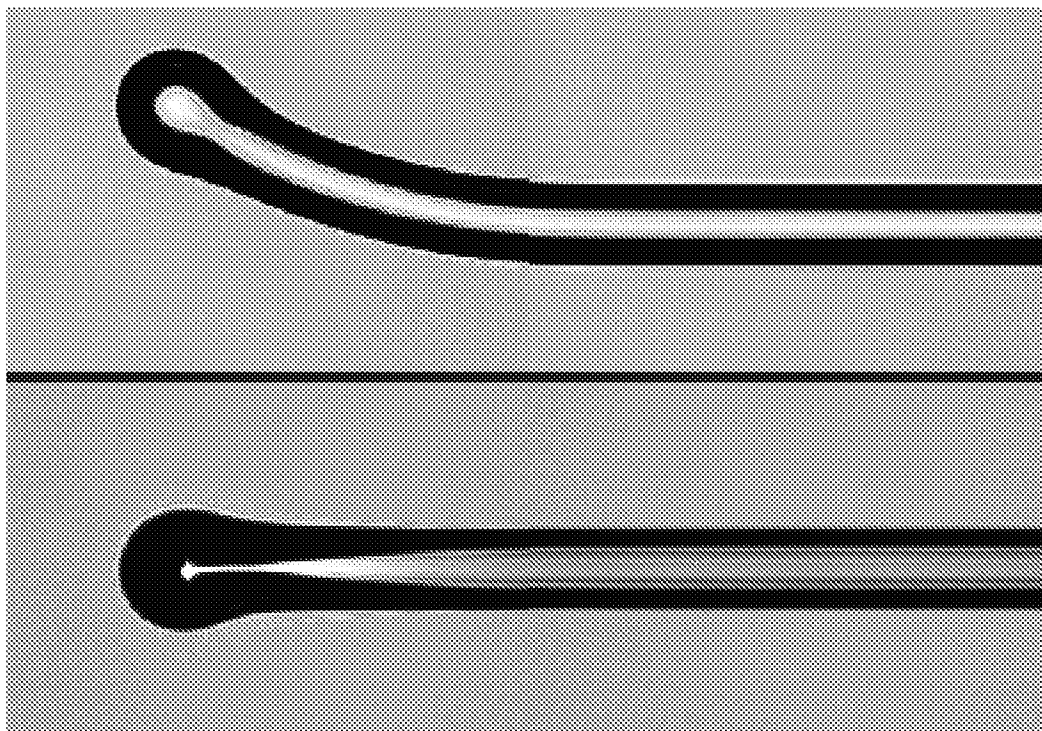

Figure 4



INTERNATIONAL SEARCH REPORT

International application No.

PCT/US15/20711

A. CLASSIFICATION OF SUBJECT MATTER

IPC(8) - G02B 6/125, 6/32 (2015.01)

CPC - G02B 6/02071, 6/125, 6/32

According to International Patent Classification (IPC) or to both national classification and IPC

B. FIELDS SEARCHED

Minimum documentation searched (classification system followed by classification symbols)

IPC(8) - G02B 6/255, 6/125, 6/32, 6/122, 6/10, 26/08 (2015.01)

CPC - G02B 6/02071, 6/125, 6/4289, 6/32

Documentation searched other than minimum documentation to the extent that such documents are included in the fields searched

Electronic data base consulted during the international search (name of data base and, where practicable, search terms used)

PATSEER (US Granted, US Applications, EP, WO, JP, DE, GB, FR, KR, ES, AU, IN, CA); ProQuest (Derwent, INSPEC, NTIS, PASCAL, Current Contents Search, Dissertation Abstracts Online, Inside Conferences); IP.com; Google Scholar; KEYWORDS: ball lens, microbend, fiber, optical, bending, splicing, coupling, fuse, heat

C. DOCUMENTS CONSIDERED TO BE RELEVANT

Category*	Citation of document, with indication, where appropriate, of the relevant passages	Relevant to claim No.
A	US 5,517,590 A (AUBORN, J et al.) May 14, 1996; figures 1, 2, 2A, 3; column 2, lines 2-15; column 3, lines 37-47; column 4, lines 1-7	1-20
A	US 8,261,442 B2 (ZHENG, W) September 11, 2012; figure 1; claim 1	1-20
A	NANONICS IMAGING LTD. "Lens Fiber Probes". February 1, 2002; [retrieved from the internet] [retrieved on 6/1/2015]. <URL: http://www.nanonics.co.il/products/spm-probes-and-nanotools/afm-probes/lens-fiber-probes.htm >; page 2, second figure; page 3, table; page 4, table	1-20

Further documents are listed in the continuation of Box C.

See patent family annex.

* Special categories of cited documents:

"A" document defining the general state of the art which is not considered to be of particular relevance

"E" earlier application or patent but published on or after the international filing date

"L" document which may throw doubts on priority claim(s) or which is cited to establish the publication date of another citation or other special reason (as specified)

"O" document referring to an oral disclosure, use, exhibition or other means

"P" document published prior to the international filing date but later than the priority date claimed

"T" later document published after the international filing date or priority date and not in conflict with the application but cited to understand the principle or theory underlying the invention

"X" document of particular relevance; the claimed invention cannot be considered novel or cannot be considered to involve an inventive step when the document is taken alone

"Y" document of particular relevance; the claimed invention cannot be considered to involve an inventive step when the document is combined with one or more other such documents, such combination being obvious to a person skilled in the art

"&" document member of the same patent family

Date of the actual completion of the international search

1 June 2015 (01.06.2015)

Date of mailing of the international search report

29 JUN 2015

Name and mailing address of the ISA/

Mail Stop PCT, Attn: ISA/US, Commissioner for Patents
P.O. Box 1450, Alexandria, Virginia 22313-1450
Facsimile No. 571-273-8300

Authorized officer

Shane Thomas

PCT Helpdesk: 571-272-4300
PCT OSP: 571-272-7774