

(No Model.)

S. R. KIRBY.
SASH HOLDER.

No. 497,581.

Patented May 16, 1893.

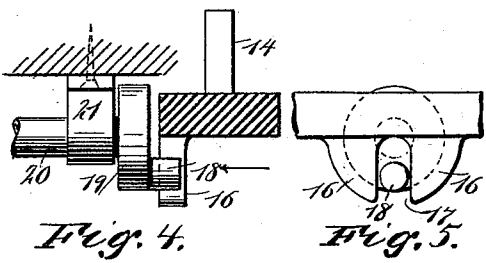
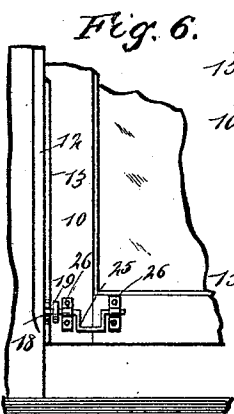
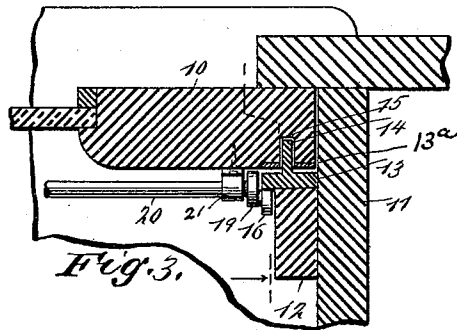
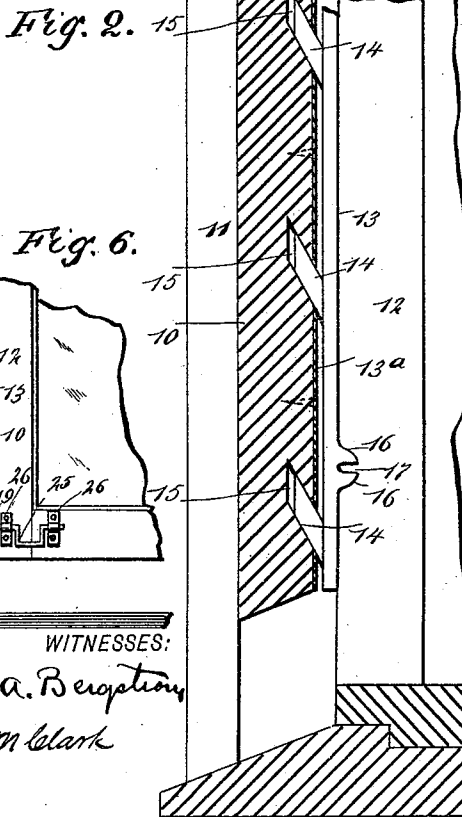
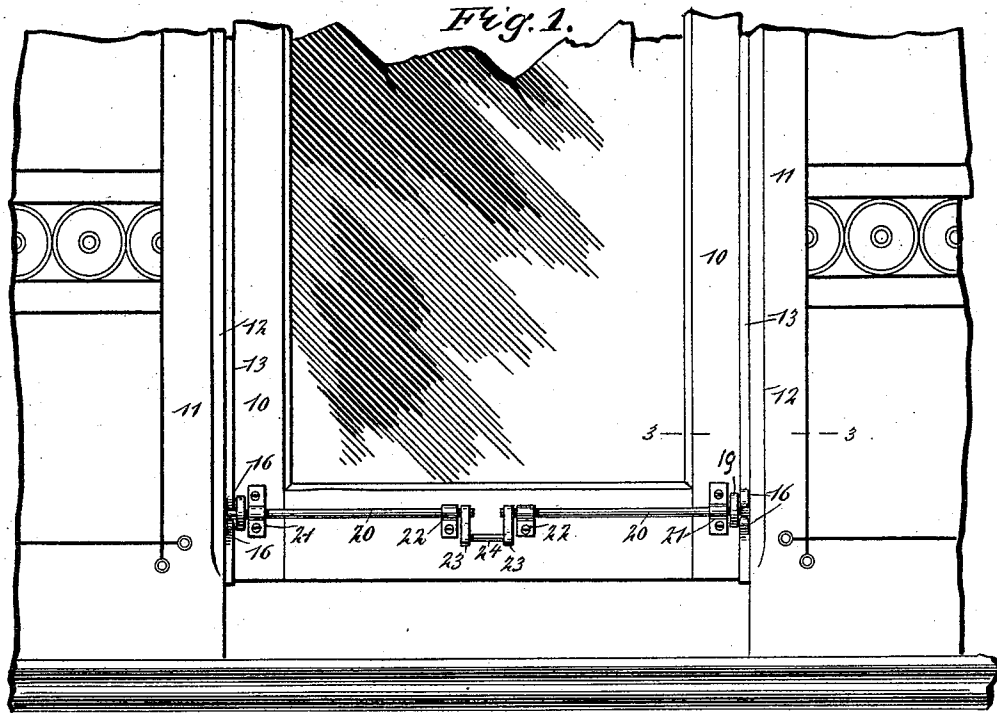

WITNESSES:

J. a. Berghman
E. M. Clark

INVENTOR

BY S. R. Kirby
Munn & Co.
ATTORNEYS.

UNITED STATES PATENT OFFICE.

STEPHEN R. KIRBY, OF NEW YORK, N. Y.

SASH-HOLDER.

SPECIFICATION forming part of Letters Patent No. 497,581, dated May 16, 1893.

Application filed December 22, 1892. Serial No. 456,052. (No model.)

To all whom it may concern:

Be it known that I, STEPHEN R. KIRBY, of the city, county, and State of New York, have invented a new and Improved Sash-Holder, of which the following is a full, clear, and exact description.

My invention relates to improvements in sash holders such as are adapted to support a window sash at any necessary or desired height, and my invention is intended particularly as an improvement on the device for which I filed an application for Letters Patent of the United States, October 5, 1892, Serial No. 447,915.

My invention is intended to improve the former device referred to by making said device easier to operate, and also to provide a lifting and locking handle by which the window may be easily raised or lowered and by which the fastener may be made to positively engage and firmly lock the sash.

To this end my invention consists in certain features of construction and combinations of parts, as will be hereinafter described and claimed.

Reference is to be had to the accompanying drawings, forming a part of this specification, in which similar figures of reference indicate corresponding parts in all the views.

Figure 1 is a broken front elevation of a car window provided with my improved holder and fastener. Fig. 2 is a broken enlarged longitudinal section of one of the sash stiles and the fastening mechanism connected therewith. Fig. 3 is a broken sectional plan on the line 3—3 in Fig. 1. Fig. 4 is an enlarged detail sectional plan showing the eccentric or crank mechanism for actuating the keeper bar. Fig. 5 is a broken end view of said mechanism, looking in the direction of the arrow in Fig. 4; and Fig. 6 is a broken detail view of a modified means of connecting with the keeper bar.

The sash 10 represents a car window sash, although the device may be applied to any sort of a window sash, and the sash is held to slide vertically in the frame 11 in the usual way, the sash being held behind the ordinary stop beads 12 between which and the sash is a little slack or space to provide for the insertion and movement of a pair of keeper bars 13 which are arranged on opposite sides

of the window and between the sash stiles and the stop beads 12, these keeper bars lying opposite wear plates 13^a on the sash and having upwardly projecting blunt teeth 14 which lie in inclined pockets 15 in the stiles of the sash.

The construction above described is exactly like that described in my former application, except that in this case the teeth 14 and the pockets 15 extend upwardly into the sash instead of downwardly. Where the teeth and pockets were arranged as in the former case, the keeper bar was inclined to catch too quickly and to bind the window sash, but when arranged as shown in Fig. 2, this difficulty is entirely obviated. The keeper bars 13 are thickened at their lower ends, as shown at 16, and these thickened portions are slotted as shown at 17, thus dividing the thickened parts into two opposite lugs, and in the slots 17 are held short studs or cranks 18 which project from disks 19 on the shafts 20, and the latter are journaled in keepers 21 and 22 on the lower portion of the sash, so as to extend across the sash at right angles to the keeper bars. The inner ends of the shaft 20 are secured to cranks 23 which are united by a rod 24 so as to form a convenient crank handle by which the shafts 20 may be oscillated, and this crank handle is preferably arranged so as to extend outward parallel with the studs or cranks 18. I have shown two shafts 20 and a separable handle attached to them, but it will be understood that a single shaft may be used and a solid handle formed on the shaft without departing from the principle of the invention. By pressing downward on the crank handle of the shafts, the cranks 18 are also thrown down and, striking the lower lugs 16, press downward on the keeper bar 13, and this movement causes the teeth 14 to slide downward in the pockets 15 and the keeper bars are jammed firmly against the beads 12, while the sash is crowded outward against the outer beads of the window frame, and thus the sash is held firmly in any place which it happens to be and there is no chance for it to rattle. By lifting upward on the crank handle, the cranks 18 are turned upward, thus lifting the keeper bars and forcing the said bars against the window sash and away from the beads 12 so that the sash may be moved

freely up and down. If the sash is dropped, the handle 24 and cranks 23 will swing downward of their own accord, aided by the weight of the keeper bars, so that the window sash will be automatically fastened and prevented from striking down violently upon the sill.

For large windows it is better to have a short crank shaft on one side of the window instead of extending it entirely across the sash, and the manner of connecting a short shaft is shown in Fig. 6. Here a shaft 25 is held in parallel keepers 26 which are arranged near one of the sash stiles, and the shaft is provided with a disk 19 and crank 18 which connects with the keeper bar in precisely the manner described above.

Having thus described my invention, I claim as new, and desire to secure by Letters Patent—

1. The combination with the vertical keeper bar to work between the inner face of the sash and the bead and provided with a slotted lug 16, of a transverse shaft for the inner face of the sash and provided at its outer end with a crank pin engaging said slot and a crank handle on the shaft by which to lift the sash and operate the shaft; the said handle when swung down throwing the keeper bar against

the bead to lock the sash and when swung up to raise the sash simultaneously moving the keeper bar away from the bead, substantially as set forth.

2. The combination with the vertical keeper bars having a smooth inner face to engage the bead, a series of upwardly and outwardly inclined teeth 14 on their outer faces to enter corresponding pockets 15 on the inner face of the sash, and slotted lugs 16 on the lower portions of their inner faces, of a shaft 20 cranked between its ends to form the handle and lift 24 and provided at its opposite ends with parallel cranks projecting in the same direction as the handle and provided with crank pins 18 entering the slots 17 of the lugs 16; whereby when the crank handle is swung down against the face of the sash the crank pins 18 will force the keeper bars into locking engagement with the window beads and when the handle is grasped and swung up in the act of raising the sash the said crank pins will throw the keeper bars away from the said beads, substantially as set forth.

STEPHEN R. KIRBY.

Witnesses:

EDWARD J. RENAHAN,
A. W. KINGSBURY.