



(86) Date de dépôt PCT/PCT Filing Date: 2001/05/01  
 (87) Date publication PCT/PCT Publication Date: 2002/03/28  
 (85) Entrée phase nationale/National Entry: 2003/03/20  
 (86) N° demande PCT/PCT Application No.: IL 2001/000388  
 (87) N° publication PCT/PCT Publication No.: 2002/025920  
 (30) Priorité/Priority: 2000/09/21 (09/666,856) US

(51) Cl.Int.<sup>7</sup>/Int.Cl.<sup>7</sup> H04M 11/06  
 (71) Demandeur/Applicant:  
SERCONET LTD., IL  
 (72) Inventeur/Inventor:  
BINDER, YEHUDA, IL  
 (74) Agent: OGILVY RENAULT

(54) Titre : SYSTEME DE COMMUNICATION TELEPHONIQUE ET PROCEDE APPLIQUE A UN CABLAGE DE RESEAU LOCAL

(54) Title: TELEPHONE COMMUNICATION SYSTEM AND METHOD OVER LOCAL AREA NETWORK WIRING

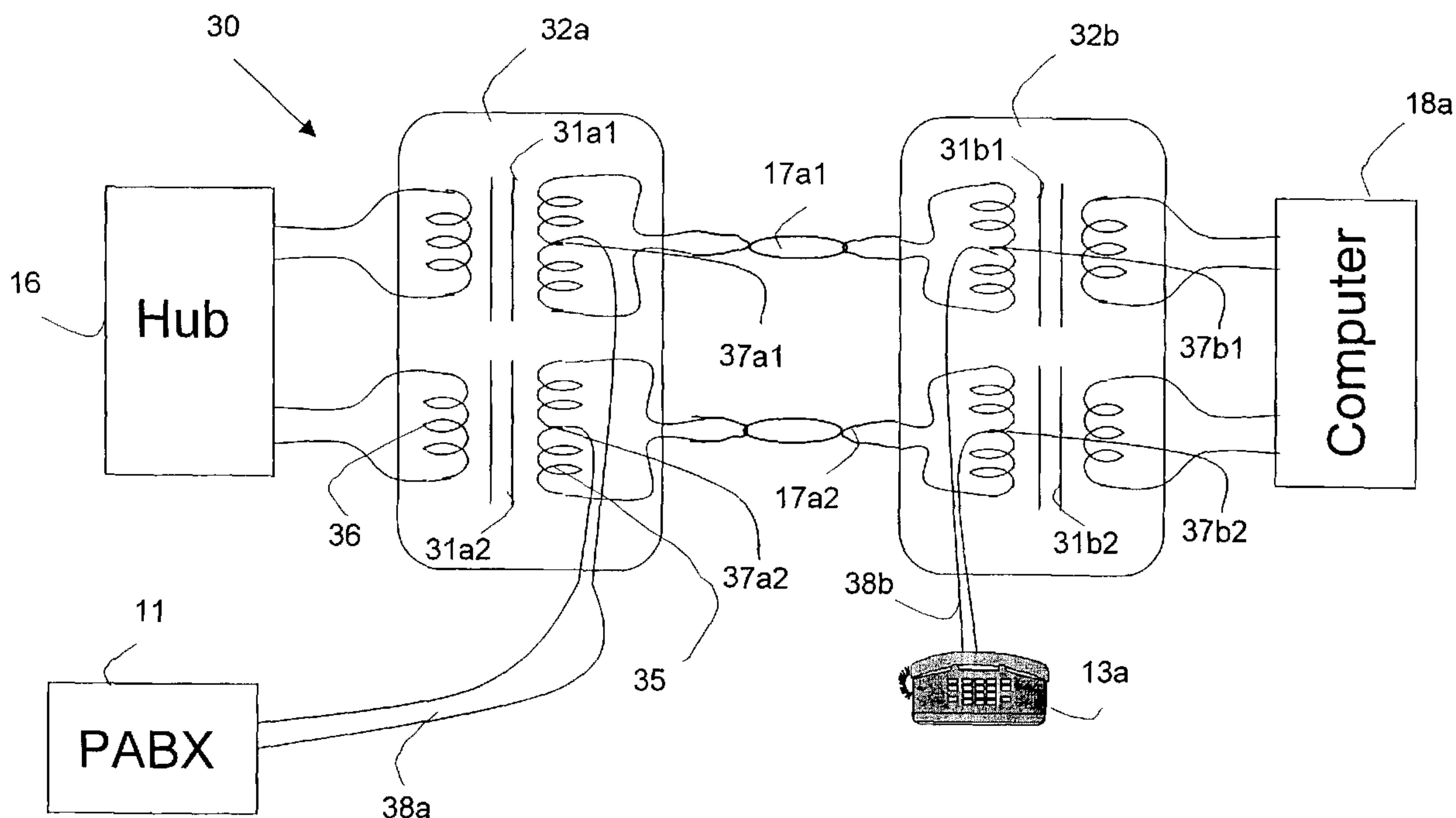

(57) Abrégé/Abstract:

A method and apparatus for enabling a local area network wiring structure to simultaneously carry digital data and analog telephone signals on the same transmission medium. It is particularly applicable to a network in star topology, in which remote data units (e.g. personal computers) are each connected to a hub through a cable comprising at least two pairs of conductors, providing a data communication path in each direction. Modules at each end of the cable provide a phantom path for telephony (voice band) signals between a telephone near the data set and a PBX, through both conductor pairs in a phantom circuit arrangement. All such communication paths function simultaneously and without mutual interference. The modules comprise simple and inexpensive passive circuit components.

## (12) INTERNATIONAL APPLICATION PUBLISHED UNDER THE PATENT COOPERATION TREATY (PCT)

(19) World Intellectual Property Organization  
International Bureau(43) International Publication Date  
28 March 2002 (28.03.2002)

PCT

(10) International Publication Number  
WO 02/25920 A1(51) International Patent Classification<sup>7</sup>: H04M 11/06

(21) International Application Number: PCT/IL01/00388

(22) International Filing Date: 1 May 2001 (01.05.2001)

(25) Filing Language: English

(26) Publication Language: English

(30) Priority Data:  
09/666,856 21 September 2000 (21.09.2000) US(71) Applicant (for all designated States except US): SER-  
CONET LTD. [IL/IL]; 16 Ha'Haroshet Street, P.O.B.  
2009, 43657 Raanana (IL).

(72) Inventor; and

(75) Inventor/Applicant (for US only): BINDER, Yehuda  
[IL/IL]; 30 Yeshurun St., 45200 Hod HaSharon (IL).(74) Agent: REINHOLD COHN AND PARTNERS; P.O.B.  
4060, 61040 Tel Aviv (IL).(81) Designated States (national): AE, AG, AL, AM, AT, AU,  
AZ, BA, BB, BG, BR, BY, BZ, CA, CH, CN, CO, CR, CU,  
CZ, DE, DK, DM, DZ, EE, ES, FI, GB, GD, GE, GH, GM,  
HR, HU, ID, IL, IN, IS, JP, KE, KG, KP, KR, KZ, LC, LK,  
LR, LS, LT, LU, LV, MA, MD, MG, MK, MN, MW, MX,  
MZ, NO, NZ, PL, PT, RO, RU, SD, SE, SG, SI, SK, SL,  
TJ, TM, TR, TT, TZ, UA, UG, US, UZ, VN, YU, ZA, ZW.(84) Designated States (regional): ARIPO patent (GH, GM,  
KE, LS, MW, MZ, SD, SL, SZ, TZ, UG, ZW), Eurasian  
patent (AM, AZ, BY, KG, KZ, MD, RU, TJ, TM), European  
patent (AT, BE, CH, CY, DE, DK, ES, FI, FR, GB, GR, IE,  
IT, LU, MC, NL, PT, SE, TR), OAPI patent (BF, BJ, CF,  
CG, CI, CM, GA, GN, GW, ML, MR, NE, SN, TD, TG).**Published:**

- with international search report
- before the expiration of the time limit for amending the claims and to be republished in the event of receipt of amendments

For two-letter codes and other abbreviations, refer to the "Guidance Notes on Codes and Abbreviations" appearing at the beginning of each regular issue of the PCT Gazette.

(54) Title: TELEPHONE COMMUNICATION SYSTEM AND METHOD OVER LOCAL AREA NETWORK WIRING

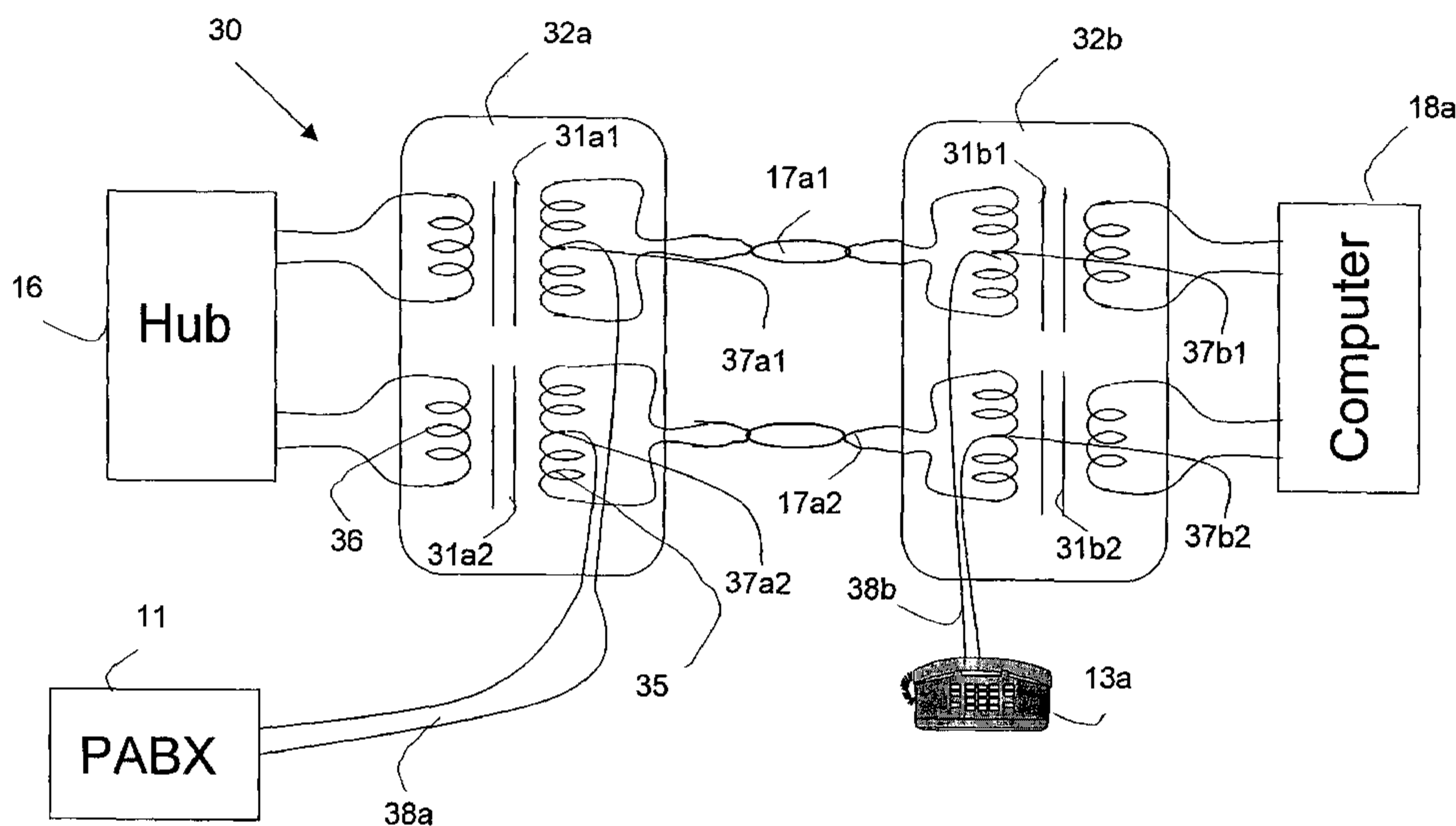

(57) **Abstract:** A method and apparatus for enabling a local area network wiring structure to simultaneously carry digital data and analog telephone signals on the same transmission medium. It is particularly applicable to a network in star topology, in which remote data units (e.g. personal computers) are each connected to a hub through a cable comprising at least two pairs of conductors, providing a data communication path in each direction. Modules at each end of the cable provide a phantom path for telephony (voice band) signals between a telephone near the data set and a PBX, through both conductor pairs in a phantom circuit arrangement. All such communication paths function simultaneously and without mutual interference. The modules comprise simple and inexpensive passive circuit components.

WO 02/25920 A1

- 1 -

**Telephone communication system and method  
over local area network wiring**

**FIELD OF THE INVENTION**

The present invention relates to the field of common networks for data communication and telephony, and, more specifically, to the networking of telephone sets within a building over digitally oriented local area network wiring, simultaneously with the data transmission.

**BACKGROUND OF THE INVENTION**

Small office and business environments commonly employ a multiplicity of work cells, each equipped with a telephone set and a computer. Two separate networks are usually employed for communication among the cells and between them and the outside world – a telephone network, connecting between the telephone sets and outside telephone lines, and a so-called local area network (LAN), connecting the computers among themselves and to outside network lines.

The term computer or personal computer will be understood to include a workstation or other data terminal equipment (DTE) or at least one digital device capable of inputting and outputting data, whereby each computer includes an interface for connection to a local area network (LAN), used for digital data transmission; any such device will also be referred to as a remote digital device. The term telephone set will be understood to include any device which can connect to a PSTN (Public Switched Telephone Network), using telephony band signals, such as fax machine, automatic answering machine or dial-up modem; any such device will also be referred to as a remote- or local telephone device.

– 2 –

Such an environment is depicted in Figs. 1a and 1b, which show a typical small office/business configuration, requiring two separate and independent networks. Fig. 1a shows a telephony network **10** comprising a PABX (Private Automatic Branch Exchange) **11**, connected via lines **12a**, **12b**, **12c** and **12d** to telephone devices **13a**, **13b**, **13c** and **13d** respectively. The telephone are of the POTS (Plain Old Telephone Service) type, requiring each of the connecting lines **12** to consist of a single pair of wires.

Fig. 1b shows a local area network (LAN) **15** for allowing communication between computers. Such a network comprises a hub (or switching hub) **16**, connected via lines **17a**, **17b**, **17c** and **17d** to computers **18a**, **18b**, **18c** and **18d** respectively. Popular types of LANs are based on the IEEE802.3 Ethernet standard, using 10BaseT or 100BaseTX interfaces and employing, for each connecting line **17**, two twisted pairs of wires – one pair for transmitting and one pair for receiving.

Installation and maintenance of two separate networks is complicated and expensive. It would therefore be advantageous, especially in new installations, to have a combined wiring network system that serves both telephony and data communication requirements.

One approach is to provide a LAN only, which serves for normal inter-computer communication, and make it serve also for telephony. One general method for this approach, in common usage today, utilizes so-called Voice-Over-Internet-Protocol (VoIP) techniques. By such techniques, known in the art, telephone signals are digitized and carried as data in any existing LAN. Systems employing such techniques are, however, complex and expensive, and the quality of the voice carried by currently available technology is low.

Another, opposite approach is to utilize an existing telephone infrastructure for simultaneously serving as both telephone and data networking. In this way, the task of establishing a new local area network in a

– 3 –

home or other building is simplified, because there are no additional wires to install.

U.S. Patent 4,766,402 to Crane teaches a way to form a LAN over two-wire telephone lines, but without the telephone service.

5           The concept of frequency division multiplexing (FDM) is well-known in the art, and provides a means of splitting the inherent bandwidth of a wire into a low-frequency band, capable of carrying an analog telephony signal, and a high-frequency band, capable of carrying data or other signals. Such a technique, sometimes referred to as ‘data over voice’, is described, for  
10           example, in U.S. Patents 5,896,443, 4,807,225, 5,960,066, 4,672,605, 5,930,340, 5,025,443 and 4,924,492. It is also widely used in xDSL systems, primarily Asymmetric Digital Subscriber Loop (ADSL) systems.

          A typical system employing FDM is illustrated in Fig. 2, which shows schematically a combined telephony/data network **20**, providing in this case  
15           connections to two work cells by means of corresponding two cables **12a** and **12b**, each comprising a single twisted pair of wires. The lower part of the spectrum of cable **12a** is isolated by Low Pass Filters (LPF) **22a** and **22b**, each connected to a respective end of the cable. Similarly, the higher part of the spectrum is isolated by respective High Pass Filters (HPF) **21a** and **21b**. The  
20           telephony network uses the lower spectrum part by connecting the telephone **13a** and the PABX **11** to the respective LPFs. In order to use the higher part of the spectrum for data communication, telephone-line modems **23a** and **23b** are respectively connected to the HPFs **21a** and **21b** at both cable ends. Hub **16** connects to modem **23a**, while, on the user side, modem **23b** connects to  
25           computer **18a**, thus offering connectivity between the computer and the hub. The spectrum of the other cable **12b** is similarly split and cable **12b** connects telephone set **13b** to PABX **11** via LPFs **22c** and **22d**, while computer **18b** connects to hub **16** via modem **23d**, coupled to HPF **21d**, and modem **23c**, coupled to HPF **21c**. Additional telephones **13** and computers **18** can be added

- 4 -

in the same manner. This prior-art concept is disclosed in U.S. Patent 4,785,448 to Reichert *et al.* (hereinafter referred to as "Reichert") and U.S. Patent 5,841,841 to Dodds *et al.* (hereinafter referred to as "Dodds"). Both Reichert and Dodds suggest a method and apparatus for applying frequency domain/division multiplexing (FDM) technique for residential telephone wiring, enabling simultaneously carrying telephone and data communication signals, as described above.

U.S. Patent 5,610,922 to Balatoni discloses a method and apparatus for transferring analog voice telephone signals and digital data service signals simultaneously from a telephone company location to a customer premises over a single twisted pair telephone line. The apparatus includes an easily installed voice plus digital data service remote terminal and voice plus digital data service central office terminal. The apparatus can provide a 3-to-1 pair gain by multiplexing signals representing the analog voice telephone signals and 4-wire digital data service signals.

Network 20, employing an FDM method, typically requires two modems (such as 23a and 23b in Fig. 2) for each connected cell. Such modems are complex and expensive. In addition, the low communication quality of a typical telephone line, which was designed to carry low-frequency (telephony) signals only, limits both the data-rate and the distance of the data communication.

The concept of forming a phantom channel to serve as an additional path in a two wire-pairs communication system is known in the art of telephony, and disclosed in several patents, classified under U.S. Class 370/200. Commonly, such a phantom channel path is used to carry power to feed remote equipment or intermediate repeaters. In some prior-art systems, exemplified by U.S. Patents 4,173,714, 3,975,594, 3,806,814, 6,026,078 and 4,937,811, the phantom channel is used to carry additional signals, such as metering and other auxiliary signals. Thus, all such systems use the phantom channel only as

- 4a -

means for helping the communication service over the main channels. None of the mentioned prior-art uses the phantom channel for carrying an additional communication type of service, or for functionally combining two distinct networks.

5 It would thus be desirable to allow a data networking system to simultaneously also provide telephone service without any additional wiring.

### SUMMARY OF THE INVENTION

It is an object of the invention to allow a data networking system to simultaneously also provide telephone service without any additional wiring.

10 This object is realized in accordance with a broad aspect of the invention by a circuit for use with a bundle containing at least two pairs of conductors, the circuit comprising:

first connections for coupling to an end of said bundle;

second connections for coupling to at least one digital device; and

15 third connections for coupling to at least one telephone device;

**characterized in that:**

two of said circuits, coupled by respective ones of said first connections to opposite ends of a respective pair of conductors in said bundle, cooperate to form at least one phantom channel allowing for telephone communication  
20 between respective telephone devices connected at opposite ends thereof via respective ones of the third connections simultaneous with digital communication between respective digital devices each coupled at opposite ends of the bundle to the second connections of a respective one of said circuits.

25 Conventional data networks use a four-conductor circuit arrangement providing two communication channels between two units. For example, in a local area network based on Ethernet 10BaseT or 100BaseTX, two pairs of conductors are employed between a hub and DTE such as a computer. By means of the invention, POTS connection, such as between exchange and

- 5 -

telephone apparatus, is accomplished simultaneously over the same four conductors used for the two communication channels without interference. The POTS service communication is accomplished via a phantom circuit arrangement over the four conductors.

5       Such configuration can be employed within small office or small business, wherein single wiring infrastructure is used for distributing both data and telephone signals from a central location, including a hub and an exchange to a remote station, each such station comprising a telephone unit and a data unit (e.g. desktop computer).

10       The present invention provides a circuit arrangement wherein a cable that includes two twisted-conductor pairs provides both a two-way data communication channel for a connected computer and, simultaneously, a path for POTS signal to and from a connected telephone set, using the phantom channel method. In the preferred embodiment, the data communication channel  
15       consists of an Ethernet IEEE802.3 LAN channel and 10BaseT, or 100BaseTX, interfaces.

      According to a specific embodiment of the invention, each two-conductor pair is terminated at each of its ends with a center tapped primary transformer winding (hereinafter cable-side winding), whereby each conductor  
20       of the pair is connected to a respective end of the cable side winding. Each winding is inductively coupled to a secondary winding (hereinafter referred to as equipment side winding), whose ends are connected to another pair of conductors that form the continuation channel for the data carrying signal, wherein the equipment side winding is connected to the data communication  
25       equipment. The center taps of each of the two primary winding at any end of the cable are connectable to the respective conductors of a telephone circuit, to carry the POTS signals. Thus, the two pairs of conductors at opposite ends of the cable, through the center taps of the respective primary transformer

- 6 -

windings, form first and second connections of the two conductor phantom channel, which is used for carrying the telephone signal.

The invention can be implemented by means of two modules each containing a respective circuit - one at each end of the two-conductor-pairs  
5 cable. Each circuit comprises two transformers, with a center-tap in the primary (cable side) winding. The module retains the two-pair data communication capability, while simultaneously including a phantom channel via the center-tap connections, for telephone service. The phantom channel can be accessed via a connector in the module. The module can be a stand-alone unit, or  
10 integrated within any unit in the network, such as a digital network hub, a telephone exchange, a server computer or telephone set. Alternatively, the module can be integrated within a wall outlet connected to one or both ends of the cable.

In another embodiment, the modules form a kit, which is used to  
15 upgrade an existing local area network to support telephone networking also.

The invention can be used in a small office or small business environment, which has a central location that comprises a telephone exchange and a digital network concentration unit (such as a hub, a switch or a router), connected to multiple remote work stations via LAN wiring.

## 20 BRIEF DESCRIPTION OF THE DRAWINGS

In order to understand the invention and to see how it may be carried out in practice, a preferred embodiment will now be described, by way of non-limiting example only, with reference to the accompanying drawings, in which:

Figs. 1a and 1b show respectively a common prior art telephone and  
25 Local Area Network configuration as used within a small office or a small business;

Fig. 2 shows a prior art telephone and local area networks using the telephone-wiring infrastructure;

- 7 -

Fig. 3 shows a combined telephone and data communication network according to the present invention;

Fig. 4 shows schematically a data communications network having multiple phantom channels according to the present invention all sharing a  
5 common return;

Fig. 5a shows schematically a computer modified according to the invention for direct coupling to a telephone set;

Fig. 5b shows schematically a telephone set modified according to the invention for direct coupling to a computer;

10 Fig. 6 shows modified wall outlet that adds a phantom channel telephone service to an existing data communication system according to the present invention; and

Figs. 7a to 7d show different views of an attachable wall plug connector that adds a phantom channel telephone service to an existing data communi-  
15 cation system according to the present invention.

### DETAILED DESCRIPTION OF THE INVENTION

In the following description it is to be noted that the drawings and descriptions are conceptual only. In actual practice, a single component can implement one or more functions; alternatively, each function can be  
20 implemented by a plurality of components and circuits. In the drawings and descriptions, identical reference numerals are used to indicate those components that are common to different embodiments or configurations.

Fig. 3 illustrates a preferred embodiment of the present invention. The network 30 is a part of an IEEE802.3 local area network, using 10BaseT  
25 interfaces. A hub 16, defining a central location, is connected to a typical computer 18a via a cable that includes two wire pairs 17a1 and 17a2. Each pair is operative to carry data in one direction only, one pair, say 17a1, carrying data from the hub 16 to the computer 18a, while the other pair, 17a2, carries

- 8 -

data in the other direction. Fig. 3 also shows a telephone set 13a, associated with computer 18a and preferably near it, and a telephone private automatic branch exchange (PABX) 11, which is preferably also at the central location. The term hub is used herein to represent any digital network concentrating unit and may equally refer to a switching hub, a router, a server computer or to any digital device having multiple data ports; any of these being also referred to herein as a central digital device. Similarly, PABX is used herein to represent any type of central telephone switching unit and will also be referred to as a central telephone device.

10 According to the invention, a signal transformer is inserted at each end of each wire pair, whereby, for example, transformer 31a1 is inserted at the end of wire pair 17a1 that is near hub 16 and transformer 31b1 is inserted at the end of wire pair 17a1 that is near computer 18a. Similarly, transformers 31a2 and 31b2 are inserted at the ends of wire pair 17a2 that are near hub 16 and computer 18a, respectively. The signal transformers bearing the prefix 31 are designed so that the signal attenuation via these transformers is negligible. Hence, the performance of the data communication network is fully retained, and the hub 16 continues to communicate fully with the computer 18a in the usual manner. Such transformers are known in the art and are often used in LANs, in order to meet isolation and common-mode rejection requirements. Commonly, such signal transformers are equipped with a primary winding and a secondary winding both being untapped coils. In the invention, each signal transformer bearing the prefix 31, say 31a2 has a primary winding 35, whose ends are connected to the respective wires of the cable, and a secondary winding 36, whose ends are connected to the respective system component (hub 16 or computer 18a).

However, unlike the conventional configuration for signal transformers, according to the present invention each primary winding 35 has a center-tap shown as 37a1 and 37a2, for the two signal transformers 31a1 and 31a2,

- 9 -

respectively. The ends of the primary windings 35 constitute first connections of a circuit comprising the two the two signal transformers 31a1 and 31a2 and serve for coupling to respective pairs of conductors in the bundle. The ends of the secondary windings 36 constitute second connections for coupling to at least one digital device such as 16 or 18; and the center-taps 37a1 and 37a2 serve as third connections for coupling to at least one telephone device such as 11 or 13. Thus, PABX 11 is connected, via two respective wires 38a, to the center-taps 37a1 and 37a2 of transformers 31a1 and 31a2. Similarly, the telephone set 13a is connected, via two respective wires 38b, to the center-taps 37b1 and 37b2 of transformers 31b1 and 31b2, respectively. In this configuration, the telephony signals are carried in a 'phantom' way together with the data communication signals, without any interference between the two. In practice, the hub side transformers 31a1 and 31a2 may be integrated to form a module 32a, while the computer side transformers 31b1 and 31b2 may be integrated to form a module 32b. While the network 30 has so far been

– 10 –

described as supporting a single computer and a single telephone, additional work cells, each comprising a telephone and a computer can be supported, whereby each computer is connected with hub **16** through a corresponding two wire pairs cable, by inserting an additional set of modules **32a** and **32b** in each  
5 such cable.

While the invention has been described specifically for 10BaseT (10Mb/s) interfaces, the invention can be equally applied to 100BaseTX (100Mb/s) interfaces. Furthermore, the invention can be equally applied in any wired networking system using at least two wire pairs. Transformers can be  
10 used in all wired communication systems whose signals do not include direct current (DC) components. In systems that use four or more pairs of wires, such as those based on the evolving 1000BaseTX Ethernet standard, each two pairs can be used to form a single phantom channel. Thus, four pairs can form two phantom channels, each carrying one POTS circuit, by terminating each pair  
15 with a transformer as described above. Alternatively and preferably, as shown in Fig. 4, three pairs **17a1**, **17a2** and **17a3** can each form a phantom channel with the fourth pair **17a4**, which serves as the common return path. In this case, each telephone circuit **13a**, **13b** and **13c** has one of its two wires connected to the center-tap **37b1**, **37b2** and **37b3** of the respective transformer **31b1**, **31b2**  
20 and **31b3** at the corresponding end of the respective pair and the other wire – to the center-tap **37b4** of the transformer **31b4** at the corresponding end of the common pair. More generally, with N pairs of conductors, each pair serving as a data channel, it is possible to similarly provide N-1 phantom channels for telephone service.

25 In the configuration shown in Fig. 3 the modules **32a** and **32b** are stand-alone modules, mechanically separate from other components in the network. However, also other configurations are possible. For example, the hub side module **32a** can be integrated, fully or in part, within the hub **16**. In such a case, the hub's existing data connection-unit (such as a distribution frame – for

- 11 -

connecting thereto all line pairs) is preferably substituted by one that includes module **32a**; in addition, a telephone connector is provided, for connecting all telephone lines (whose other ends are connected to their respective center taps in module **32a**) to the PABX. Alternatively, module **32a** can be similarly  
5 integrated within PABX **11**, whereby an appropriate connection with the hub is provided.

Fig. 5a shows schematically an arrangement where the computer side module **32b** is integrated, fully or in part, within the computer **18a**. Thus, the secondary windings **36** of the transformers **31a1** and **31a2** are connected to  
10 receiver and transmitter circuitry **39a** and **39b** within the computer **18a**. The ends of the primary windings **35** of the transformers **31a1** and **31a2** are connected to a standard socket outlet **40** for connecting to the network. The center-taps **37a1** and **37a2** are connected to a standard telephone outlet **41**, enabling connection thereto of a telephone set such as designated **13a** in Fig. 3.

Fig. 5b shows schematically the complementary arrangement where the  
15 module **32b** is integrated the telephone set **13a**. Thus, the secondary windings **36** of the transformers **31a1** and **31a2** are connected to a standard outlet **42** for connecting thereto a computer such as designated **18a** in Fig. 3. The ends of the primary windings **35** of the transformers **31a1** and **31a2** are connected to a  
20 standard socket outlet **43** for connecting to the network. The center-taps **37a1** and **37a2** are connected to telephone circuitry **44**, within the telephone set **13a**.

Alternatively, the computer side module **32b** can be integrated within a wall connector allowing direct or indirect connection to an existing wall socket outlet. Thus, such a wall connector can be constituted by a substitute wall  
25 socket having integrated therein a pair of signal transformers and two female outlets for connecting a computer and telephone thereto, respectively. Alternatively, the wall connector can be constituted by a plug connector having integrated therein a pair of signal transformers and two female outlets for connecting a computer and telephone thereto, respectively. Such a plug

– 12 –

connector allows a computer and telephone to be connected to an existing wall socket outlet without requiring any modification thereto.

Fig. 6 shows the faceplate of a modified socket outlet **45** according to the invention. Two conductor pairs are connected to the outlet at the rear (not shown in the Figure), connected to the primary windings of two signals transformers housed in it (not shown in the Figure). The secondary windings of the transformers are connected to RJ-45 data connector **46**, while the center taps are connected to the RJ-11 telephony connector **47**. Such an outlet is physically similar in size, shape, and overall appearance to a standard outlet, so that such an outlet can be substituted for a standard outlet in the building wall. No changes are required in the overall LAN line layout or configuration. Such an outlet can easily substitute an existing standard data outlet to thus additionally provide telephony support. Thus a conventional outlet has a single female connector having two pairs of wiper contacts connected to the respective twisted-wire pairs for data transmission and reception. A computer is plugged into such a conventional outlet via a single male connector (plug) having four pins: two for handling data transmission and two for handling data reception. On inserting the plug into the socket outlets, the pins brush against the wiper contacts in the socket outlet, thus establishing electrical connection between the two.

The invention allows for the conventional outlet to be replaced by a modified outlet having therein a pair of signal transformers, the ends of whose respective primary windings are adapted to be connected to the ends of a respective conductor pair in the network. The secondary winding of each signal transformer is connected internally to a respective pair of wiper contacts of a first female connector. Thus, the ends of both secondary windings are connected to first female connector by means of four wiper contacts in total. The respective center-taps of each of the two primary windings are connected to a pair of wiper contacts in a second female connector proximate the first

- 13 -

female connector. Thus, a computer can be connected, via four pins of a suitable jack plug, to the first female connector, while a telephone can be connected, via two pins of a suitable jack plug to the second female connector. The two wire pairs **17a1** and **17a2** are routed and connected to such an outlet, which will now comprise two faceplate connectors – a data connector (e.g. RJ-45 for 10BaseT) and a telephone connector (e.g. RJ-11).

Such an implementation requires that the socket outlets in an existing data network be replaced by a modified outlet according to the invention. Figs. 7a to 7d show various views of a plug assembly **50** according to the invention for operation in 10BaseT or 100BaseTX environment that allows the invention to be implemented without requiring any modification to the data network or to the existing socket outlet. In use, the plug assembly **50** is plugged into a standard socket outlet and is retained therein by means of a latch **51**. The plug assembly **50** contains the module **32b** connected to separate data- and telephony socket outlets **52** and **53** in a similar manner to the modified socket outlet **45** described above with reference to Fig. 6. A standard RJ45 jack plug **54** is connected to the module **32b** for mating with the wall outlet when plugged into its socket. The jack plug **54** thus includes two pairs of pins each connected to the primary winding of a respective signal transformer within the module **32b**. The secondary windings of the two signal transformers are connected to respective wiper contacts in the data-telephony socket outlet **52**. The respective center-taps of each of the primary windings are connected to a pair of wiper contacts in the telephony socket outlet **53** proximate the data-telephony socket outlet **52**. Cables from the computer and the telephone set terminate in standard jack plugs that are plugged into the respective data- and telephony socket outlets **52** and **53** within the plug assembly **50**. Thus, the plug assembly **50** obviates the need for any changes to be made to the existing infrastructure.

– 14 –

As mentioned above, 10BaseT and 100BaseTX interfaces, as well as other data communication interfaces, often include signal transformers in the line connection circuitry, in order to meet isolation and common-mode rejection requirements. In such cases, additional transformers, though possible,  
5 are not required and the method of the present invention can be implemented by adding center-tap connections to the respective windings of the existing transformers and using them to form a phantom channel, to serve for telephone connection in the manner described above. Alternatively, the existing transformers can be substituted by ones with center-taps as specified above.

10 It is noted that, while a phantom channel has been known in the art, its use in the system and method disclosed herein is novel, because:

(a) Local area networks (LANs) in general, and Ethernet networks in particular, currently do not employ phantom channels, nor is any configuration employing such channels specified in the IEEE802.3 standards; the concept is  
15 known in the realm of telephony only, which is very different from that of data communication LANs.

(b) Using a phantom channel itself to carry POTS service is not known in the art; rather, phantom channels are used only to carry power to remote units and/or management- or control signals to support the main service that is  
20 provided by the two conductor pairs.

While the invention is described above relating to hub units, it is clear that any other multi-port data communication device can be used, such as switch, router or gateway.

The present invention also embraces a method for upgrading an existing  
25 local area network (LAN) installation that includes a two-conductor pair cable between two digital devices, to also and simultaneously convey signals between two telephone devices, the method comprising:

(a) inserting a first pair of signal transformers having center-tapped primary windings at a first end of the cable, with respective ends of

– 15 –

the primary windings connected to respective conductors of the cable; and

- 5 (b) inserting a second pair of signal transformers having center-tapped primary windings at a second end of the cable, with respective ends of the primary windings connected to respective conductors of the cable;

thereby allowing respective secondary windings of each signal transformer to be connected to the digital devices and allowing the respective center-taps of the signal transformers to be connected to telephone equipment.

- 10 If the LAN already includes signal transformers that do not have center-taps, they are, in step (a) above, replaced by the specified transformers or, alternatively, a center-tap is added to each primary winding.

- 15 While the invention has been described with respect to a limited number of embodiments, it will be appreciated that many variations, modifications and other applications of the invention may be made.

- 16 -

**CLAIMS:**

1. A circuit (32a) for use with a bundle containing at least two pairs of conductors (17a1, 17a2), the circuit comprising:

first connections for coupling to an end of said bundle;

5 second connections for coupling to at least one digital device (16,18);  
and

third connections (38) for coupling to at least one telephone device (11,13);

**characterized in that:**

10 two of said circuits (32a, 32b), coupled by respective ones of said first connections to opposite ends of a respective pair of conductors in said bundle, cooperate to form at least one phantom channel allowing for telephone communication between respective telephone devices connected at opposite ends thereof via respective ones of the third connections simultaneous with  
15 digital communication between respective digital devices each coupled at opposite ends of the bundle to the second connections of a respective one of said circuits.

2. The circuit according to Claim 1, comprising at least two signal transformers (31a1, 31a2), each signal transformer having a primary winding  
20 (35) and a secondary winding (36), the primary winding having a center-tap (37a1, 37a2), wherein:

the first connections are coupled to respective ones of the primary windings, the second connections are coupled to respective ones of the secondary windings, and

25 the third connections are coupled to respective ones of the center-taps.

3. A module (32) including:

a casing accommodating therein the circuit according to Claim 1 or 2,

- 17 -

a first connector (54) for coupling to the first connections in said circuit,  
at least one second connector (52) for coupling to respective ones of the  
second connections in said circuit, and

at least one third connector (53) for coupling to respective ones of the  
5 third connections in said circuit.

4. The module according to Claim 3, wherein at least one of said first,  
second or third connectors includes an off-the-shelf connector.

5. The module according to Claim 4, wherein the off-the-shelf connector is  
selected from the group RJ-11, RJ-45.

10 6. The module according to any of Claims 3 to 5, wherein the first  
connector (54) is constituted by a plug assembly protruding from the casing.

7. The module according to any of Claims 3 to 5, being a combination  
outlet.

8. The combination outlet according to Claim 7, wherein the first  
15 connector (54) includes female connectors for accommodating respective  
conductors of the bundle.

9. The combination outlet according to Claim 7 or 8, being dimensioned to  
conform to an existing wall-mounted connector of a data communications  
network.

20 10. The combination outlet according to Claim 7, wherein the first  
connector (54) is constituted by a plug assembly protruding from the casing for  
removably coupling with a socket outlet of a data network.

11. A communications network (30) comprising a bundle containing at least  
two pairs of conductors (17a1, 17a2) routed between a first and second  
25 location;

- 18 -

**characterized in that:**

a respective circuit according to Claim 1 or 2 is connected at each end of the bundle so as to cooperatively provide a phantom channel for conveying telephone signals between telephone devices (11) situated at opposite ends of the bundle simultaneous with digital signals via respective data channels formed by pairs of said conductors.

12. The communications network according to Claim 11, comprising N pairs of conductors connected via respective ones of said circuits to provide N-1 phantom channels and N data channels.

10 13. The communications network (30) according to Claim 11 or 12, wherein at least one of said circuits is contained within a module (32), comprising:

a casing accommodating therein the circuit according to Claim 1 or 2,  
a first connector (54) for coupling to the first connections in said circuit,  
at least one second connector (52) for coupling to respective ones of the  
15 second connections in said circuit, and

at least one third connector (53) for coupling to respective ones of the third connections in said circuit.

14. The communications network according to Claim 13, wherein at least one of said first, second or third connectors includes an off-the-shelf connector.

20 15. The communications network according to Claim 14, wherein the off-the-shelf connector is selected from the group RJ-11, RJ-45.

16. The communications network according to any of Claims 13 to 15, wherein the first connector (54) is constituted by a plug assembly protruding from the casing.

25 17. The communications network according to any of Claims 13 to 15, wherein the module is a combination outlet.

- 19 -

18. The communications network according to Claim 17, wherein the combination outlet is adapted for wall-mounting and the first connector (54) includes female connectors for accommodating respective conductors of the bundle.
- 5 19. The communications network according to Claim 17 or 18, wherein the combination outlet is dimensioned to conform to an existing wall connector of the data communications network.
20. The network of any one of Claims 11 to 19, wherein each of said data channels conforms to the IEEE802.3 standard.
- 10 21. A digital device for use in the communication network (30) according to Claim 11 or 12 including therein the circuit according to Claim 1 or 2.
22. The digital device according to Claim 21, wherein the circuit is at least partially accommodated in the module according to any one of Claim 3 to 8.
- 15 23. A telephone device for use in the communications network (30) according to Claim 11 or 12 including therein the circuit according to Claim 1 or 2.
24. The telephone device according to Claim 23, wherein the circuit is at least partially accommodated in the module according to any one of Claim 3 to 8.
- 20 25. A method for enabling a bundle containing two pairs of conductors, which are normally operative to convey data between at least two digital devices, to also and simultaneously convey signals between at least two telephone devices, the method comprising:
- 25 (a) connecting to a first end of the two pairs of conductors a first circuit providing a first connection of a phantom channel, and

- 20 -

(b) connecting to a second end of the two pairs of conductors a second circuit providing a second connection of the phantom channel; thus allowing two telephone devices to be connected to the first and second connections respectively of said phantom channel.

5 26. The method of Claim 25, wherein at least one of steps (a) and (b) comprises:

(i) inserting a pair of signal transformers having center-tapped primary windings at a first end of the bundle, with respective ends of the primary windings connected to the first end of each of the two pairs of conductors;

10 thereby allowing respective secondary windings of the signal transformers to be connected to one of the digital devices and allowing the respective center-taps of the signal transformers to be connected to one of the telephone devices.

15 27. The method of Claim 25 or 26, wherein at least the first circuit is connected to a respective one of the telephone devices using a telephone connector.

28. The method of Claim 27, wherein said telephone connector is of RJ-11 type.

20 29. The method of Claim 25 or 26, wherein at least the first circuit is coupled to a respective one of the digital devices using a data connector.

30. The method of Claim 29, wherein said data connector is of RJ-45 type.

31. The method of any one of Claims 25 to 30, when used to upgrade an existing data network wiring to simultaneously carry telephone signals.

- 21 -

32. The method of any one of Claims 25 to 31, including providing at least the first circuit is in discrete form.

33. The method of any one of Claims 25 to 31, wherein step (a) includes connecting the first end of the two pairs of conductors to an outlet containing  
5 said first circuit.

34. The method of any one of Claims 25 to 31, wherein step (a) includes connecting the first end of the two pairs of conductors to one of the telephone devices containing said first circuit.

35. The method of any one of Claims 25 to 31, wherein step (a) includes  
10 connecting the first end of the two pairs of conductors to one of the digital devices containing said first circuit.

36. The method of any one of Claims 25 to 35, wherein the bundle carries signals conforming to the IEEE802.3 standard.

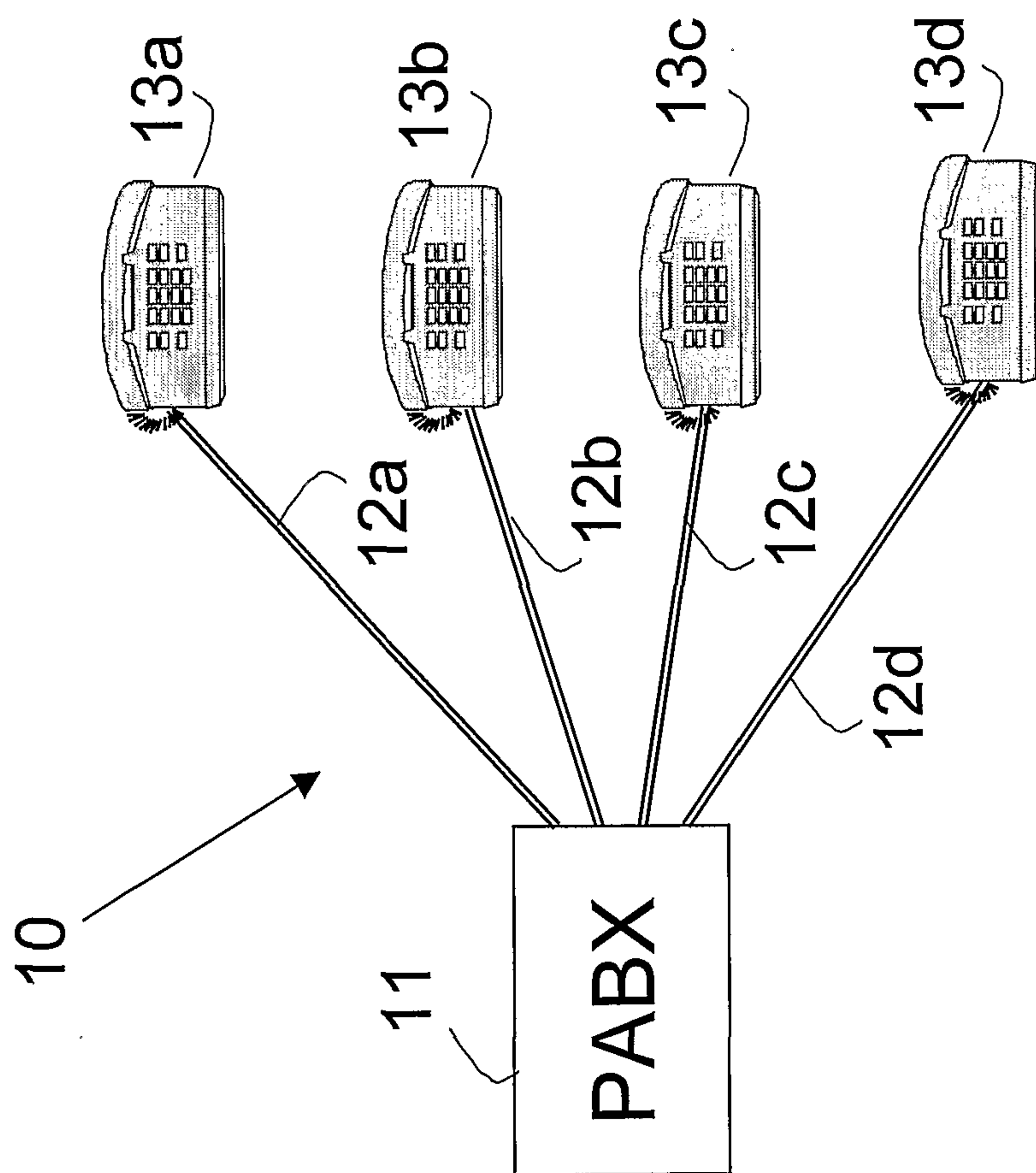
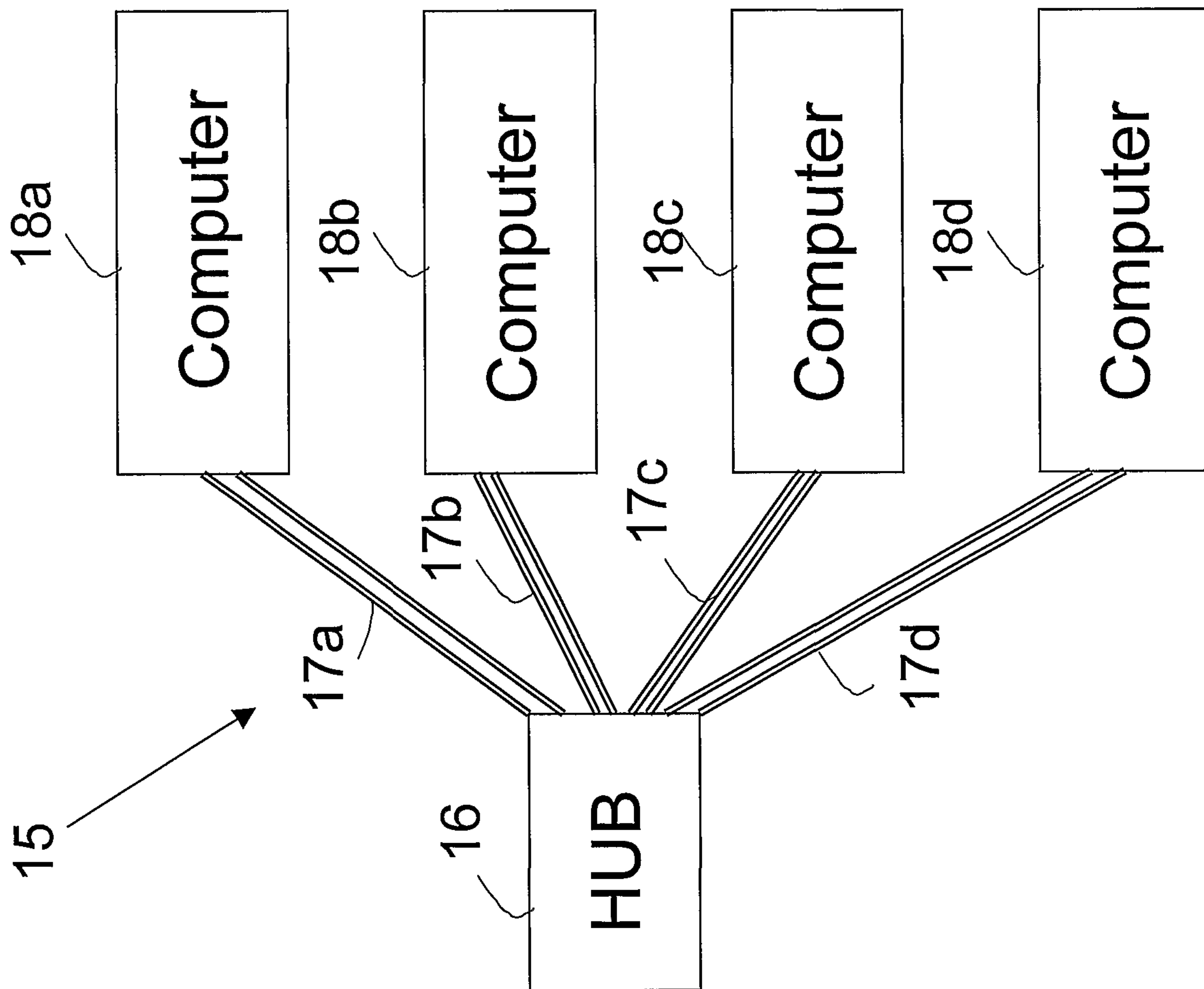

Fig. 1a (Prior-Art)



**Fig. 1b**  
**(Prior-Art)**

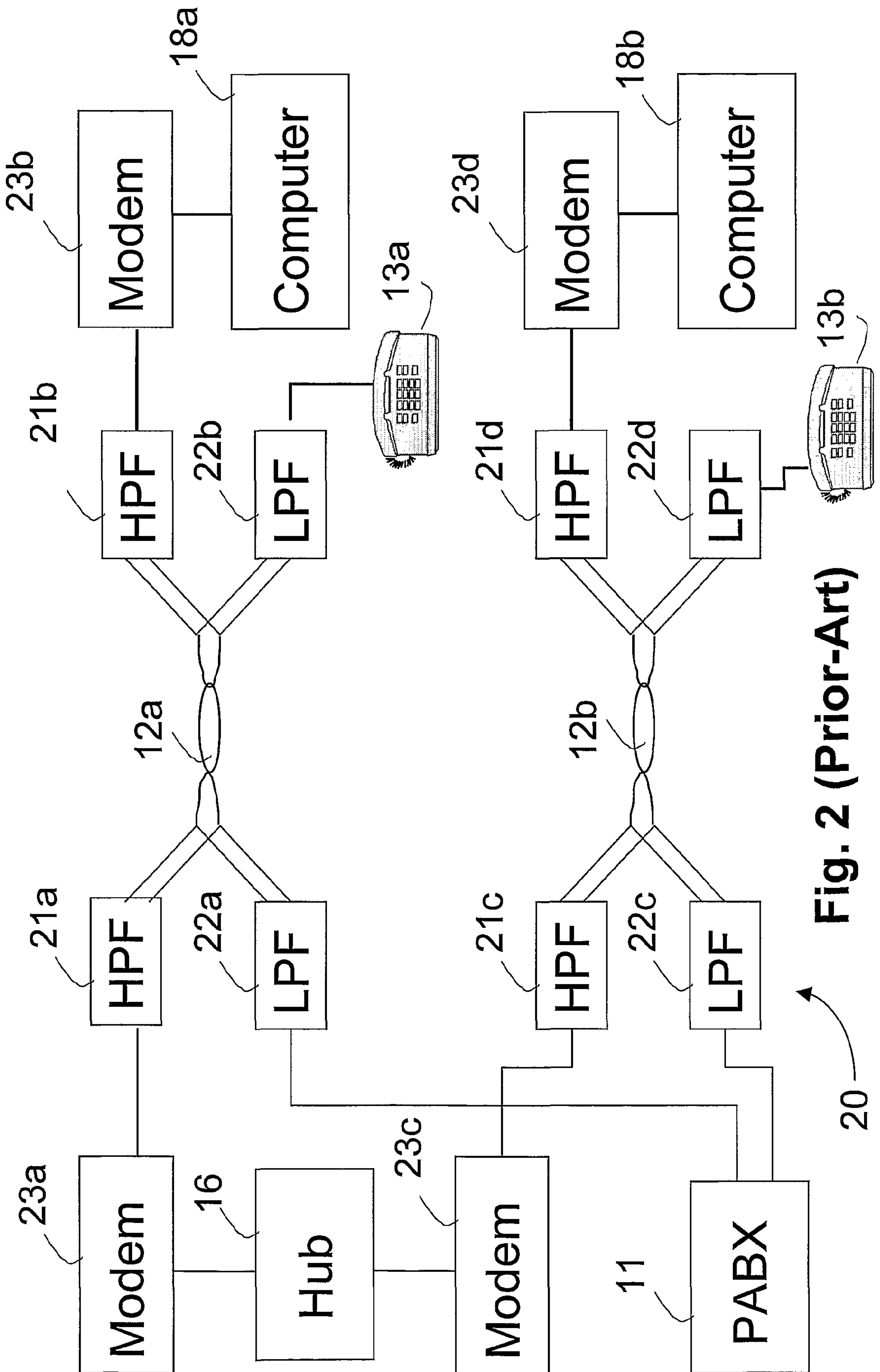

Fig. 2 (Prior-Art)

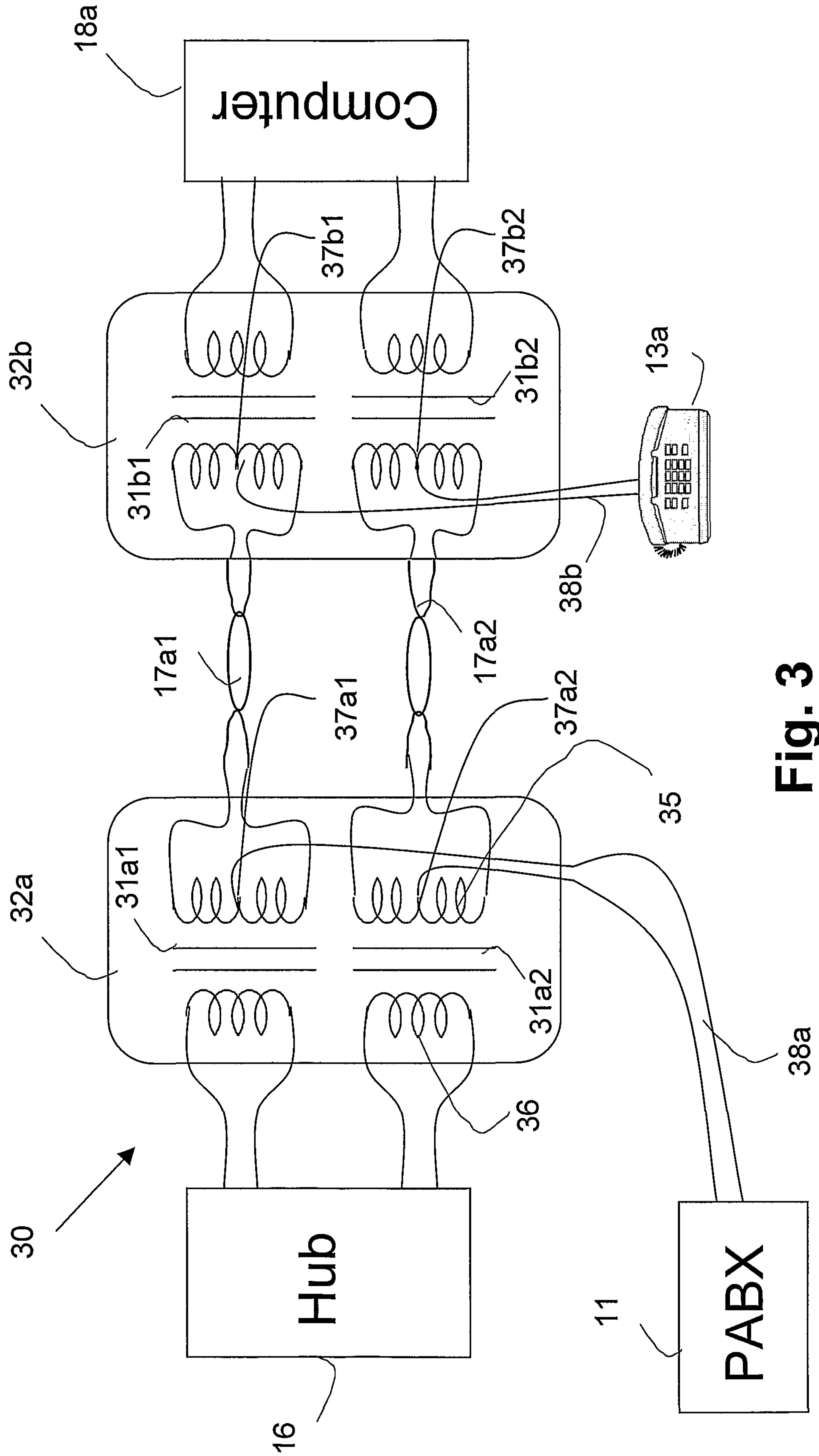

Fig. 3

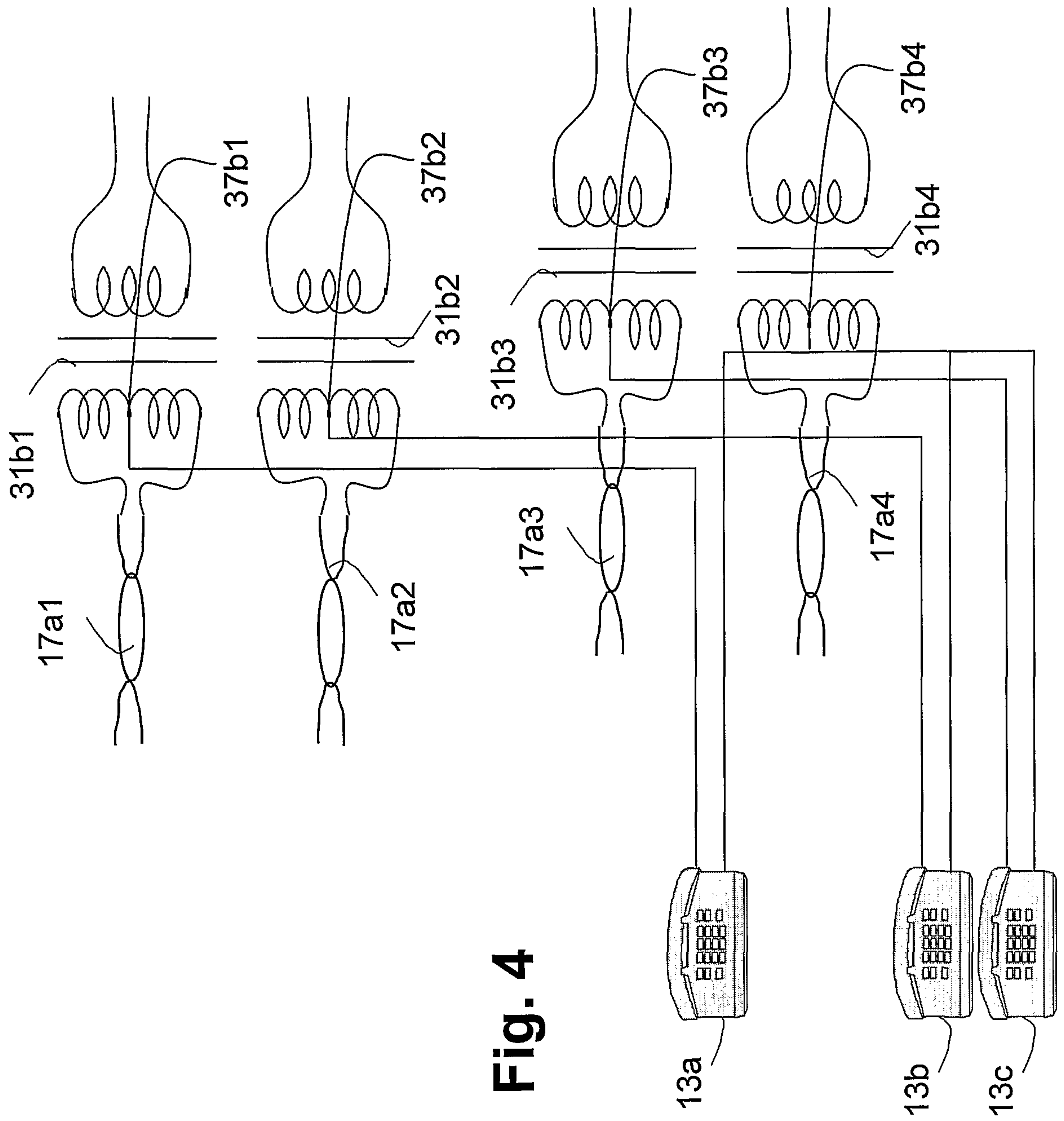

Fig. 4

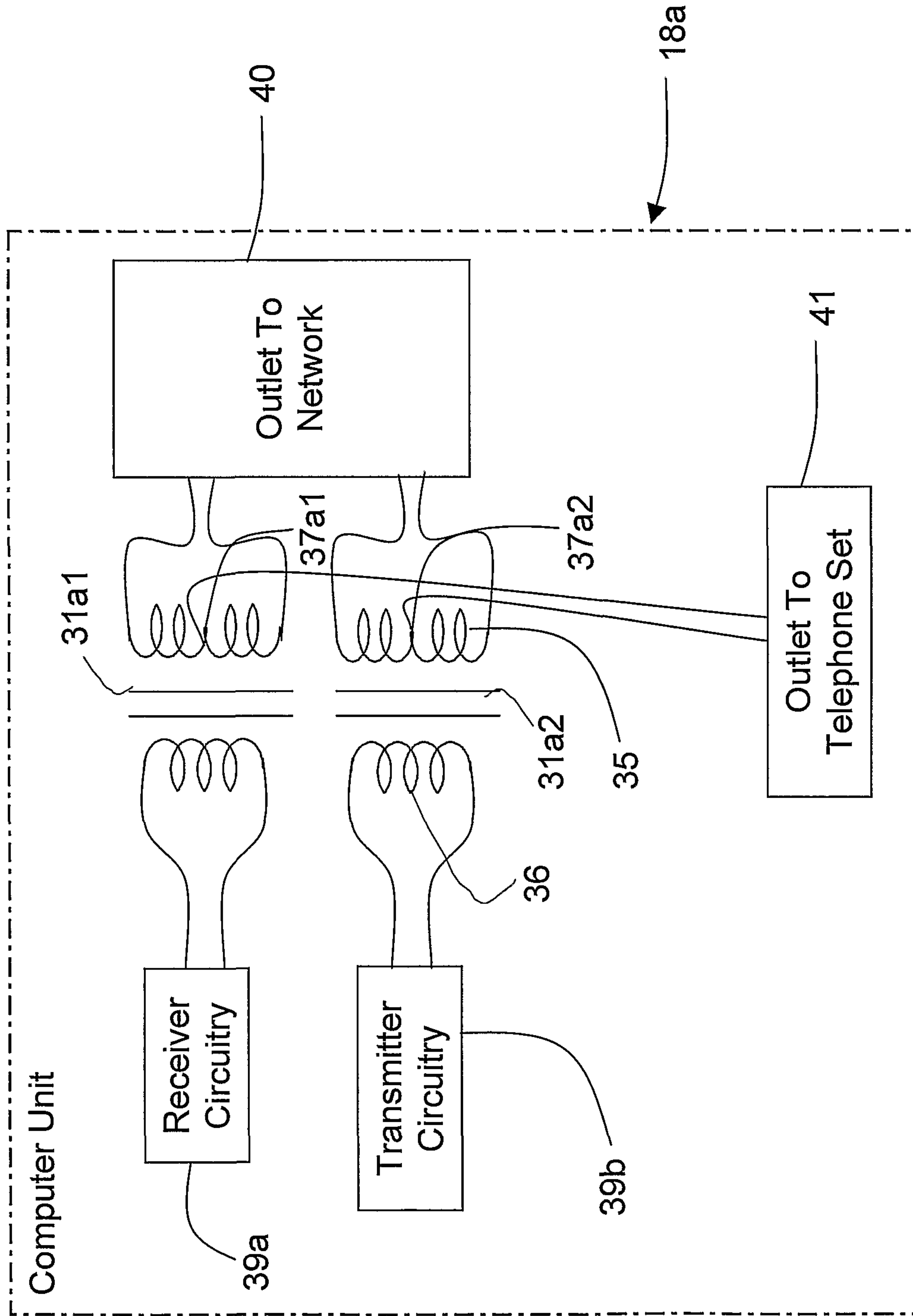

Fig. 5a

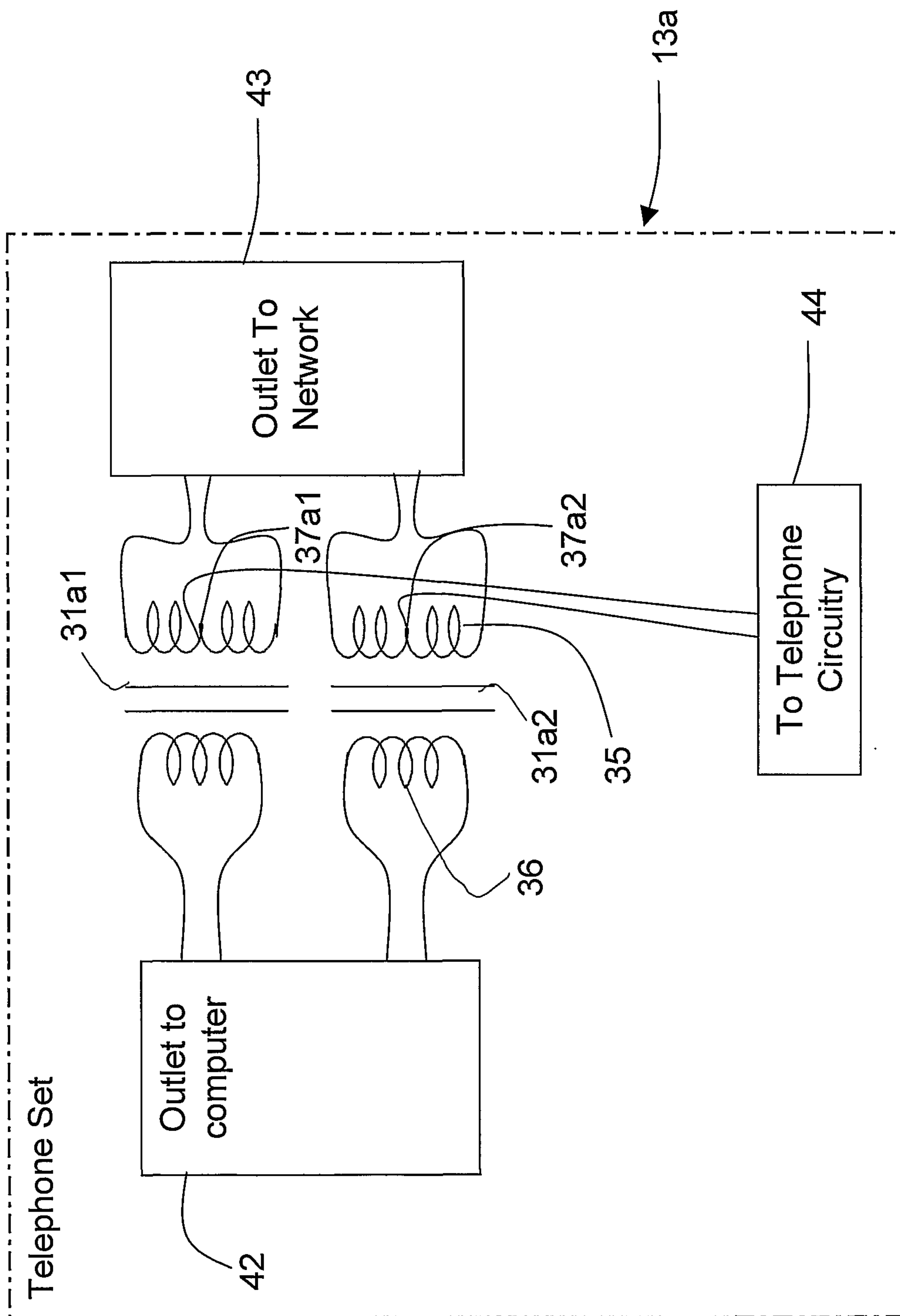

Fig. 5b

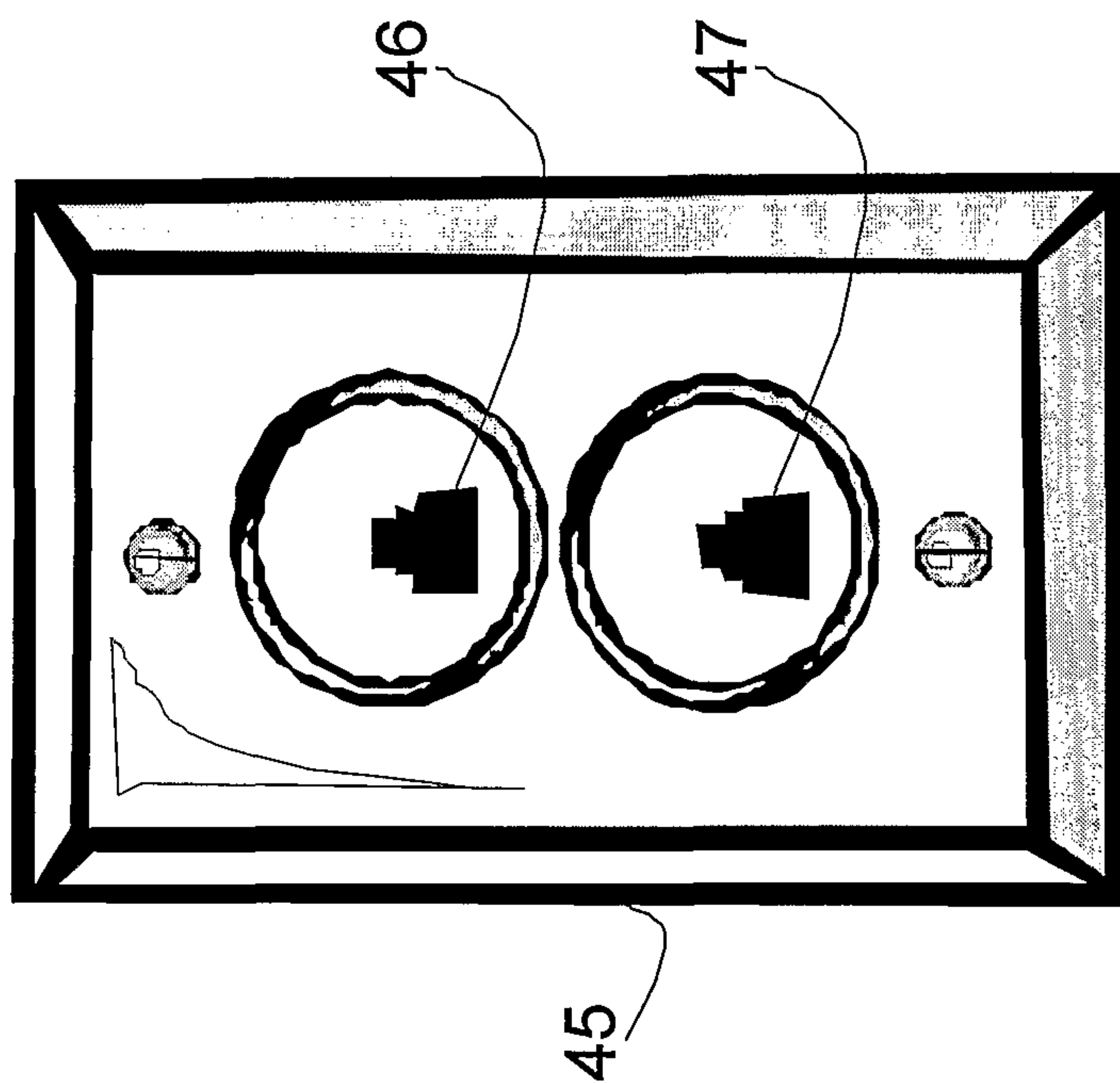

Fig. 6

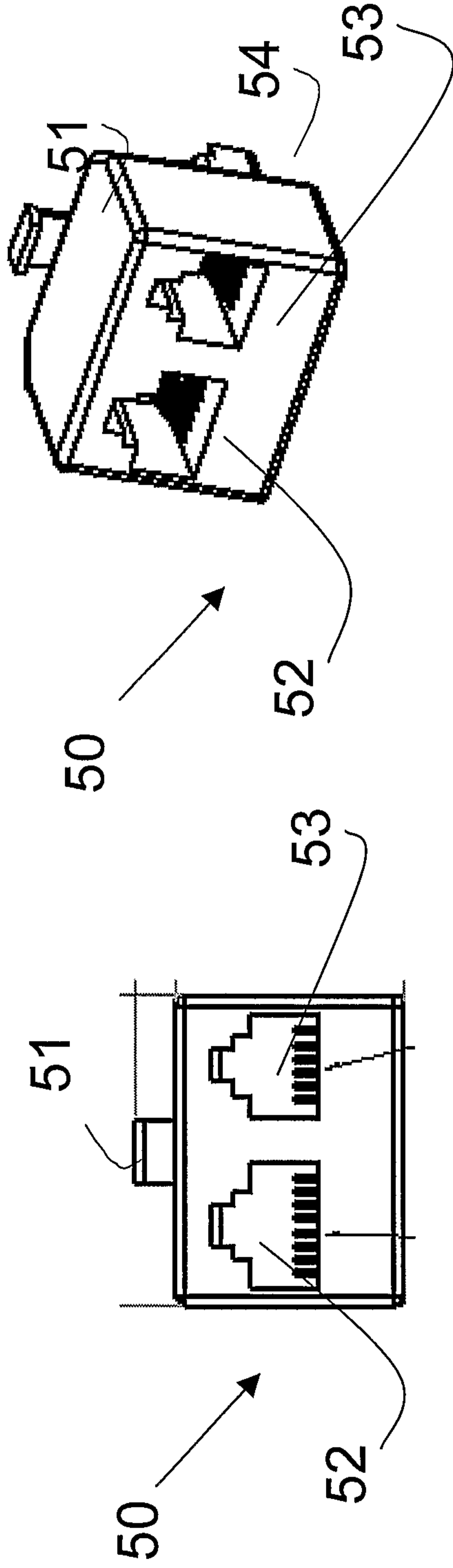

Fig. 7c

Fig. 7d

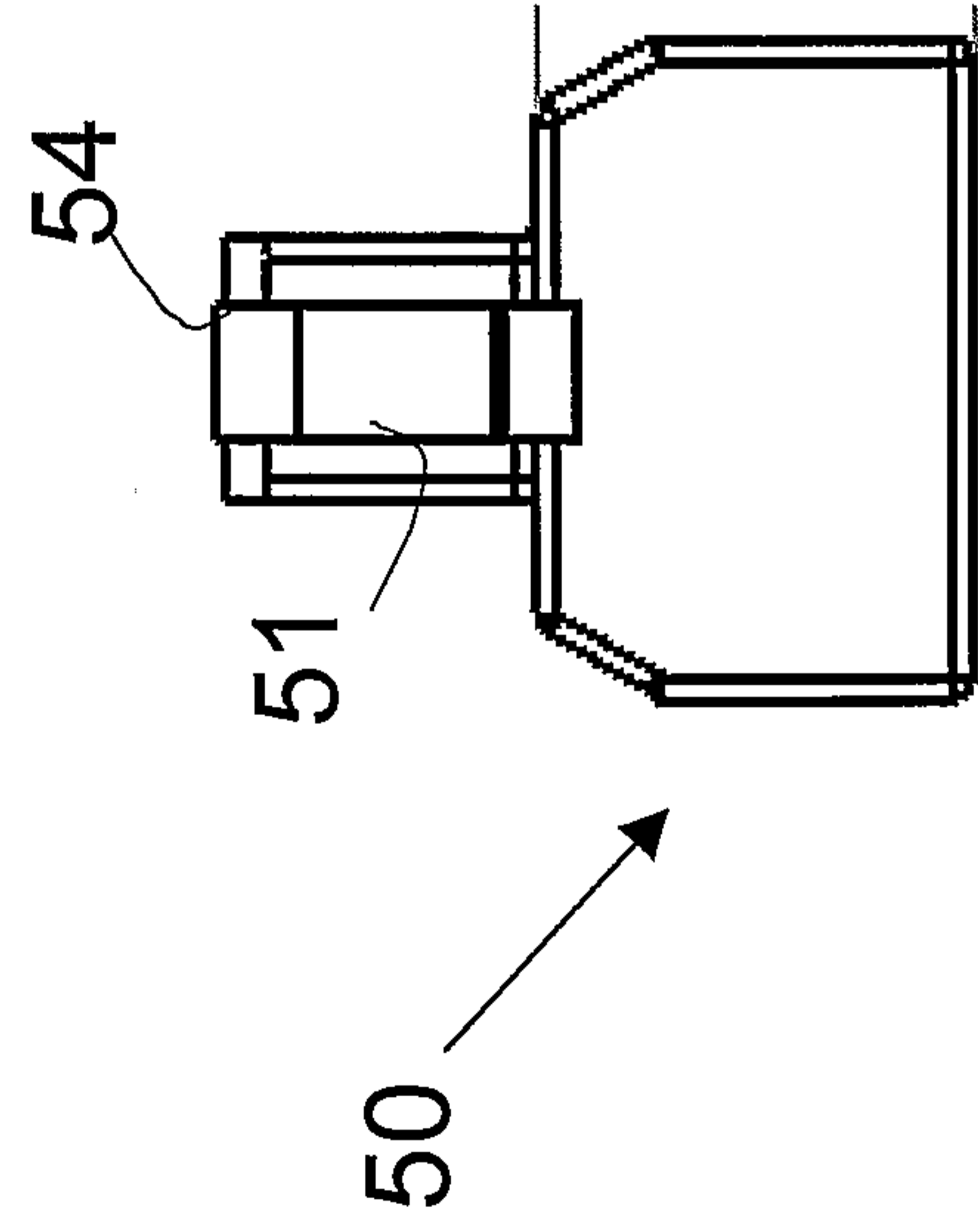

Fig. 7a

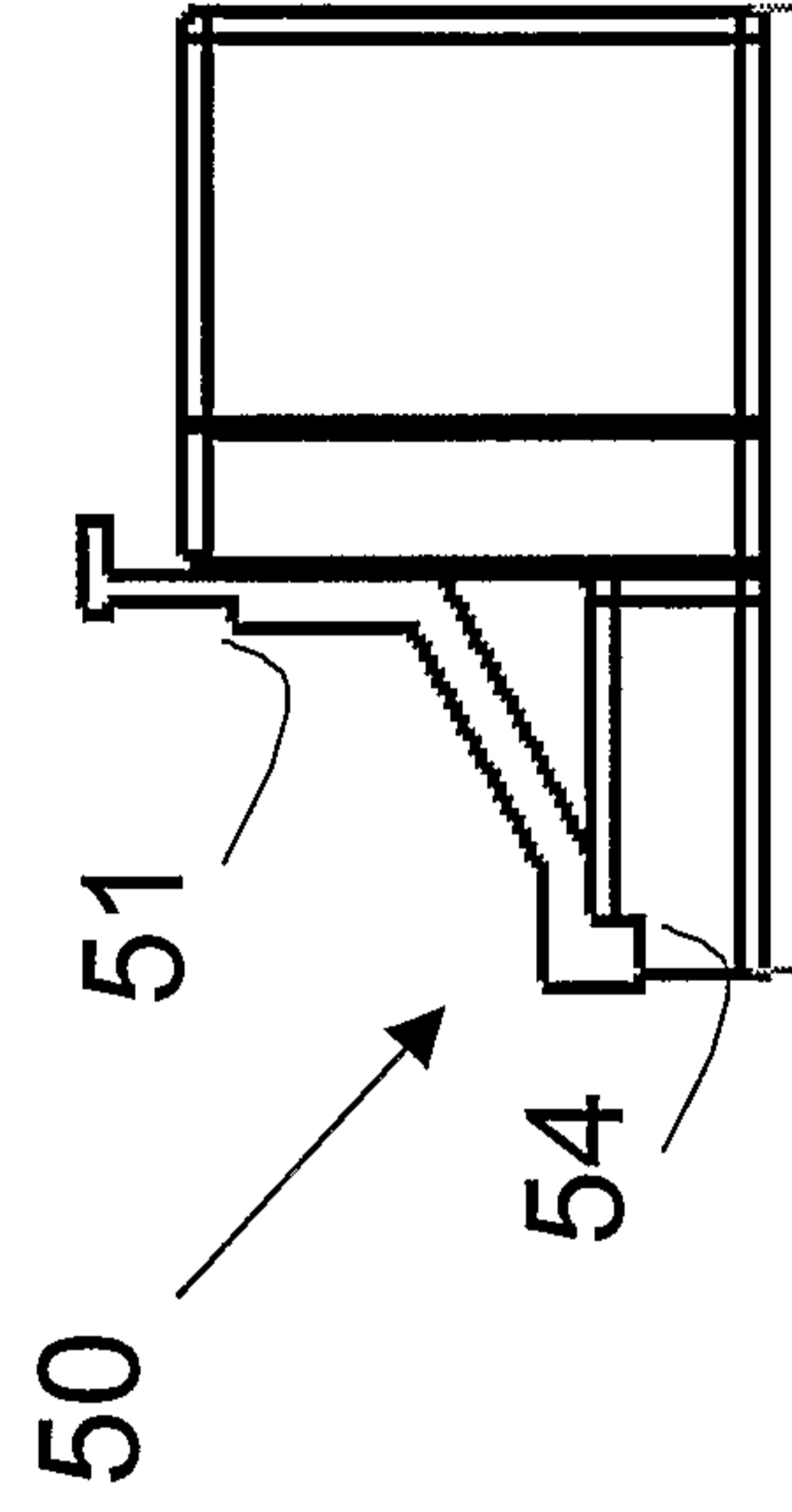

Fig. 7b

